

# Kollmorgen Housed Direct Drive Rotary (DDR) Motors Selection Guide

with AKD™ Servo Drive Systems



**KOLLMORGEN**®

*Because Motion Matters™*

# Kollmorgen. Every solution comes from a real understanding of OEM challenges.

**The ever-escalating demands of the marketplace mean increased pressure on OEMs at every turn.** Time constraints, demands for better performance, having to think about the next-generation machine even before the current one is built, tight budgets, and high expectations; Kollmorgen's innovative motion solutions and broad range of quality products help engineers not only overcome these challenges but also build truly differentiated machines.

**Because motion matters, it's our focus.** Motion can distinctly differentiate a machine and deliver a marketplace advantage by improving its performance. This translates to overall increased efficiency on the factory floor. Perfectly deployed machine motion can make your customer's machine more reliable and efficient, enhance accuracy and improve operator safety. Motion also represents endless possibilities for innovation. We've always understood this potential, and thus have kept motion at our core, relentlessly developing products that offer precision control of speed, accuracy and position in machines that rely on complex motion.

**Removing the Barriers of Design, Sourcing, and Time**

At Kollmorgen, we know that OEM engineers can achieve a lot more when obstacles aren't in the way. So, we knock them down in three important ways:

**Integrating Standard and Custom Products**

The optimal solution is often not clear-cut. Our application expertise allows us to modify standard products or develop totally custom solutions across our whole product portfolio so that designs can take flight.

**Providing Motion Solutions, Not Just Components**

As companies reduce their supplier base and have less engineering manpower, they need a total system supplier with a wide range of integrated solutions. Kollmorgen is in full response mode with complete solutions that combine programming software, engineering services and best-in-class motion components.

**Global Footprint**

With direct sales, engineering support, manufacturing facilities, and distributors across North America, Europe, Middle East, and Asia, we're close to OEMs worldwide. Our proximity helps speed delivery and lend support where and when they're needed.

**Financial and Operational Stability**

Kollmorgen is part of Danaher Corporation, our \$13B parent company. A key driver in the growth of all Danaher divisions is the Danaher Business System, which relies on the principle of "kaizen" – or continuous improvement. Using world-class tools, cross-disciplinary teams of exceptional people evaluate processes and develop plans that result in superior performance.

# Table of Contents

▶ <b>Housed Direct Drive Rotary® (DDR) Motor</b>	<b>4</b>
▶ <b>Direct Drive Technology</b>	<b>8</b>
▶ <b>AKD™ Servo Drive</b>	<b>10</b>
▶ <b>Co-Engineering Capabilities</b>	<b>14</b>
▶ <b>Housed DDR Motor System Summary</b>	<b>15</b>
▶ <b>Housed DDR Drawings and Performance Data</b>	
D(H)06x	16
D(H)08x	20
D(H)10x	24
D(H)14x	28
▶ <b>Custom Applications</b>	<b>32</b>
▶ <b>Application Notes</b>	<b>33</b>
▶ <b>Model Nomenclature</b>	<b>34</b>
▶ <b>MOTIONEERING® Application Engine</b>	<b>35</b>

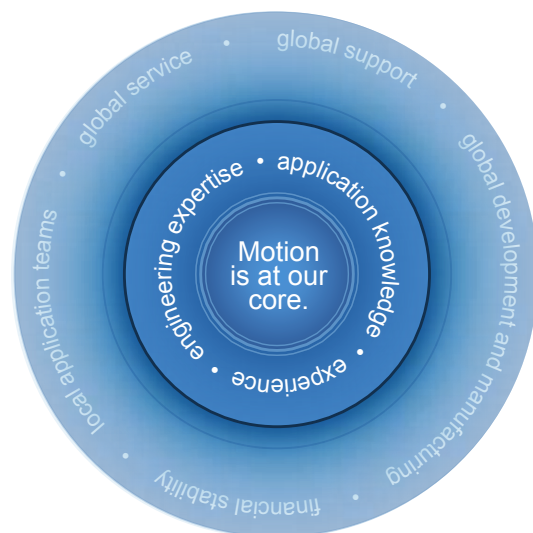

# Housed Direct Drive Rotary (DDR) Motor

**Our Housed Direct Drive Rotary (DDR) motor series offer a high performance, zero maintenance servo solution.** They achieve very high torque density through the combination of large diameter, short length, and a high number of magnetic poles.

By pairing the Housed DDR motor series with our wide range of plug-and-play Ethernet-based AKD™ servo drives, you can optimize performance and increase the machine's overall effectiveness. The DDR motor can be used as a flexible indexer, providing programmable, rapid, indexing far exceeding the throughput of conventional mechanical or variable reluctance technology indexers. It can also be used for replacing mechanical transmissions such as gearboxes, timing belts, and rack and pinion reducers.

## The Benefits of Housed DDR Motor

---

- Zero Maintenance with Greater Accuracy and Higher Bandwidth
  - Smoother velocity and reduced, audible noise
  - Power transmission without backlash
  - Transmission elements such as couplings, toothed belts, spindles, and other fitted components can be eliminated
  - No gearboxes, no lubrication required
- Wide Range of Sizes and Torque to Cover any Direct Drive Rotary (DDR) Application
  - Increased performance for the entire system
  - Flat, compact drive solution
  - Easily mix / match motors and drives (without serial numbers)
  - Speeds up to 800 rpm for continuous velocity applications
- Simplified, High Torque Density Permanent Magnet Design
  - Provides more speed and torque vs. variable reluctance motors
  - Rapid indexing of large inertia loads with peak torque up to 990 lb-ft
  - Carry heavy loads for indexing with axial loading up to 12,700 lbs
  - Operate motor with significant offset loads up to 472 lb-ft
  - Large through bore providing run process fluids, pneumatic, and electrical through center of motor
  - Reduced audible noise, fewer parts and lower cost of ownership
  - More compact machine and reduced design time

# Housed DDR Motor

## Application Problem

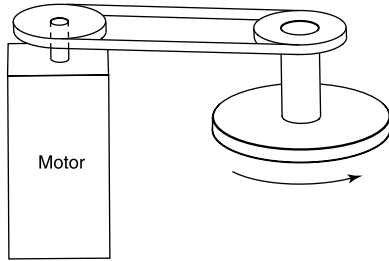

## Solution

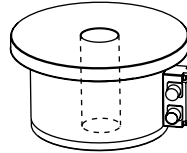

**DDR**

## Benefits

### Belt/pulley

- Zero maintenance
- No belt adjustment/replacement
- No belt compliance
- Better servo performance
- Clean mechanical assembly
- Flat profile
- Quiet
- Reduced number of parts
- Hollow shaft

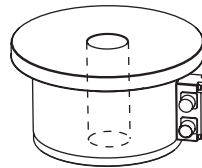
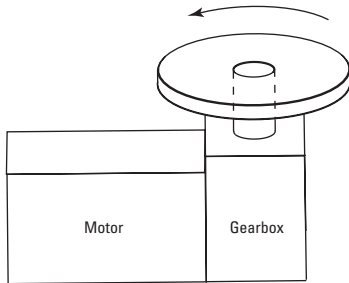

**DDR**

### Gearmotors/right angle/in-line

- Zero maintenance
- No gearbox lubrication
- No gearbox backlash
- Better servo performance
- Flat profile
- Quiet
- Hollow shaft

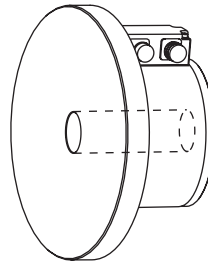
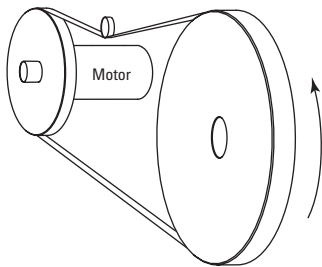

**DDR**

### Large Vertical Wheel

- Zero maintenance
- No belt adjustment/replacement
- No belt compliance
- Better servo performance
- Faster index times
- Clean mechanical assembly
- Quiet
- Reduced number of parts
- Hollow shaft

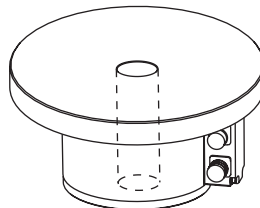
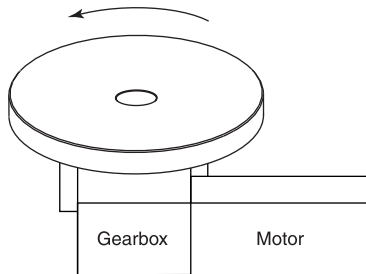

**DDR**

### Rotary Indexer

- Zero maintenance
- No gearbox lubrication
- No gearbox backlash
- Better servo performance
- Quiet
- Reduced number of parts
- Hollow shaft

Housed DDR motors are multi-pole (16 to 32) hollow shaft motors with their own bearings and high-resolution encoder system. They are coupled directly to the load and enable very precise and repeatable systems. Housed DDR motors are maintenance free and run more quietly and with better dynamics than systems that use gears, belts, cams or other mechanical transmission components.

### DDR Motor Features

- Four frame sizes
- Robust cross-roller bearing
- Dual bearing option
- IP67 option
- Continuous torque range: 5.8 Nm (4.3 lb-ft) to 339 Nm (250 lb-ft)
- Optimized torque output with high-pole count efficient electromagnetic design
- Integrated high-resolution sine-encoder
- 134,217,728 counts per rev resolution, 27 bits
- Feedback accuracy: +/- 26 arc-sec
- Repeatability better than 1 arc-sec

### Housed DDR Advantage

Consider how a Housed DDR motor improved a medical manufacturing machine.

Product is located at the steel pins on the outside of the machine's turret as shown. The 115 kg load wheel has an inertia of 20 kg-m<sup>2</sup>. There are 96 steel pins for an index angle of 3.5 degrees to move.

**The move is accomplished in less than 100 ms.**



### Realized Housed DDR Benefits

#### The Direct Drive Advantage

The following improvements were observed compared to the previous design that used a mechanical indexer:

#### Improved Repeatability

The Housed DDR demonstrated a repeatability better than 1 arc-second which was substantially better than the mechanical indexer.

#### No Degradation

Direct drive system performance, accuracy and repeatability do not degrade over time as they do with a mechanical indexer. With a mechanical indexer, as parts wear over time, the accuracy and repeatability degrade.

#### Immediate Stop

The direct drive system can immediately stop if there is a process error. The mechanical indexer required several cycles to stop which could cause tooling and machine damage.

#### Greatly Reduced Audible Noise

With the mechanical indexer, the noise was at a level such that two people would have to yell to hear each other. By contrast, if you turned your back to the Housed DDR, you could barely detect that it was running.

#### Easy Profile Change

Motion parameters such as index angle, speed, acceleration, and dwell are very simple to change with the Housed DDR. The mechanical indexer does not support flexible motion profiles.

#### Better Value

The Housed DDR is attractively priced compared to the mechanical indexer it replaced. When the other advantages listed above are also considered, the Housed DDR was the obvious choice.

# Direct Drive Technology

Conventional servo systems commonly have a mechanical transmission which can consist of gears, gearheads, belts/pulleys or cams connected between the motor and the load.

With Direct Drive Technology, the mechanical transmission is eliminated and the motor is coupled directly to the load.

## Why Use Direct Drive Technology?

### Increased Accuracy and Repeatability

A “precision” planetary gearhead could have a backlash of 1 arc-minute. This can result in the load moving by 1 arc-minute with an absolutely stationary drive motor. Kollmorgen’s standard direct drive rotary (DDR) servomotors have repeatability better than 1 arc-second. Therefore, a direct drive motor can hold a position 60 times better than a conventional motor/gearhead.

The increased accuracy of direct drive technology results in a higher quality product out of the machine:

- Print registration is more accurate
- Cut or feed lengths can be held more precisely
- Coordination with other machine axes is more accurate
- Indexing location is more exact
- Tuning issues due to backlash are eliminated

### Higher Bandwidth

Mechanical transmission components impose a limit on how fast a machine can start and stop and also extend the required settling time. These factors limit the possible throughput of a machine.

Direct drive technology removes these limitations and allows for much faster start/stop cycles and also provides greatly reduced settling time. This will allow a greater throughput from the machine. Users of direct drive systems have reported up to a 2X increase in throughput.

### Improved Reliability and Zero Maintenance

Gears, belts, and other mechanical transmission parts break. By eliminating these parts and using DDR motors, the reliability of the machine is improved. Gearheads require periodic lubrication and/or replacement in aggressive start/stop applications. Belts require periodic tightening. There are no time-wear components in a direct drive motor and consequently they require zero maintenance.

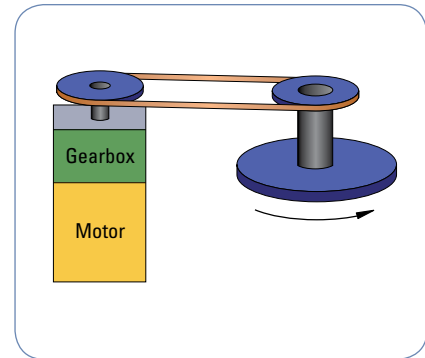

Servomotor and Gearhead

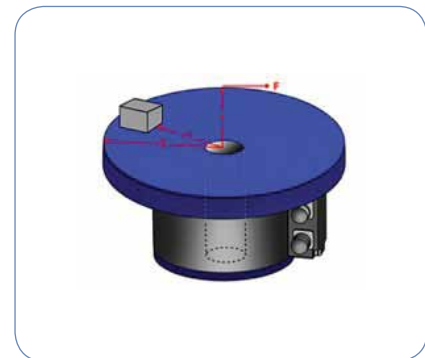

Direct Drive Motor

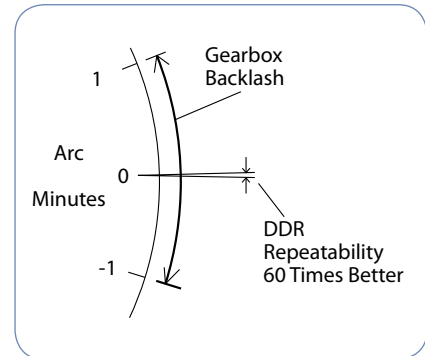

Improved Repeatability

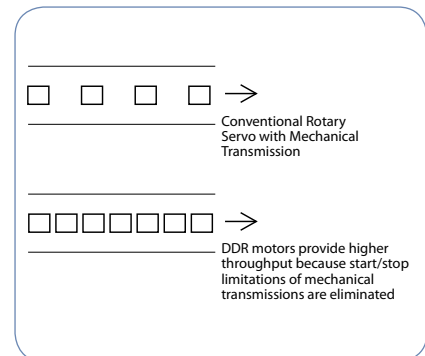

Increased Throughput



## Fewer Parts

With direct drive motors, all you need is the motor and the mounting bolts. This often replaces many parts including brackets, guards, belts, pulleys, tensioners, couplings, and bolts, resulting in:

- Fewer parts on the BOM. Less parts to purchase, schedule, inventory and control, and less parts to assemble.
- Assembly time of the servo drops from several hours with the mechanical transmission to several minutes with the DDR.
- Reduced cost. Although a direct drive motor may carry a small price-premium compared to a motor/gearhead with the same torque, consider that there is an overall cost reduction when eliminating the parts and labor of all the extra components required in a servo system with mechanical transmission.

## No Inertia Matching

Servo systems with mechanical transmissions require inertia matching that limits the reflected load inertia at five to ten times the motor inertia. If this limitation is not met, the system becomes difficult to control due to instability issues. Inertia matching limitations of mechanical transmission systems often force machine designers to use a larger motor than would otherwise be required just to satisfy the inertia matching requirement.

Such sizing conventions are not required with direct drive technology. Since the motor is directly connected to the load, the inertia of the motor and the load become a common inertia. Therefore, no inertia matching is required when using DDR. DDR applications have run with inertia ratios greater than 11,000:1.

## Reduced Audible Noise

Machines with DDR motors have audible noise levels as low as 20 dB less than the same machine with a mechanical transmission.

## Three DDR Product Categories to Choose From

Kollmorgen's 50 years of electromagnetic and electromechanical design experience combined with our quality and service, allowed us to refine and expand DDR technology into three product categories for easy installation, use, and short lead times: KBM [Frameless DDR](#), [Housed DDR](#), and the [Cartridge DDR](#). This allows you to select the right DDR solution for your application.

### KBM Series Frameless DDR

Frameless motors include a rotor and stator as separate components which are integrated into, ride on the bearings of, and become a part of the driven load. Frameless motors offer the most compact and lightweight DDR solution available. The KBM series is Kollmorgen's latest Frameless DDR product. It provides excellent torque/volume with the use of a proprietary neodymium-iron magnet rotor structure and skewed armature assembly.

### Housed DDR

The Housed DDR is a housed motor assembly featuring a factory aligned high-resolution feedback device and precision bearings, allowing it to function as the core of rotary indexing and rate table applications. The system can also be used as a flexible indexer, providing programmable, rapid indexing far exceeding the throughput and accuracy of conventional mechanical or variable reluctance technology indexers.

### Cartridge DDR

This motor is the first in the industry to combine the space-saving and performance advantages of Frameless DDR technology with the ease of installation of a full-frame motor. Consisting of a rotor, stator, and factory-aligned high-resolution feedback device, the motor uses the machine's bearings to support the rotor. An innovative compression coupling engages the rotor to the load and the frame of the motor mounts to the machine with a bolt circle and pilot diameter just like a conventional servomotor, saving space and design time and simplifying the overall system.

## DDR Applications

Format	Where Used
KBM Frameless DDR	Application where size and weight must be absolutely minimized
Housed DDR	Applications where the load rides on the motor's bearings such as indexing or rate tables
Cartridge DDR	Any application with existing bearings

# AKD™ Servo Drive

**Our AKD series is a complete range of Ethernet-based servo drives that are fast, feature-rich, flexible and integrate quickly and easily into any application.\*** AKD ensures plug-and-play commissioning for instant, seamless access to everything in your machine. No matter what your application demands, AKD offers industry-leading servo performance, communication options, and power levels, all in a smaller footprint.

This robust, technologically advanced family of drives delivers optimized performance, when paired with our best-in-class components; producing higher quality results at greater speeds and more uptime.

\* Patents pending.

## The Benefits of AKD Servo Drive

- Optimized Performance in Seconds
  - Auto-tuning is one of the best and fastest in the industry
  - Automatically adjusts all gains, including observers
  - Immediate and adaptive response to dynamic loads
  - Precise control of all motor types
  - Compensation for stiff and compliant transmission and couplings
- Greater Throughput and Accuracy
  - Up to 27-bit-resolution feedback yields unmatched precision and excellent repeatability
  - Very fast settling times result from a powerful dual processor system that executes industry-leading and patent pending servo algorithms with high resolution
  - Advanced servo techniques such as high-order observer and bi-quad filters yield industry-leading machine performance
  - Highest bandwidth torque-and-velocity loops. Fastest digital current loop in the market
- Easy-to-Use Graphical User Interface (GUI) for Faster Commissioning and Troubleshooting
  - Six-channel real-time software oscilloscope commissions and diagnoses quickly
  - Multi-function Bode Plot allows users to quickly evaluate performance
  - Auto-complete of programmable commands saves looking up parameter names
  - One-click capture and sharing of program plots and parameter settings allow you to send machine performance data instantly
  - Widest range of programming options in the industry
- Flexible and Scalable to Meet Any Application
  - 3 to 96 Arms continuous current; 9 to 192 Arms peak
  - Very high power density enables an extremely small package
  - True plug-and-play with all standard Kollmorgen servomotors and positioners
  - Supports a variety of single and multi-turn feedback devices—Smart Feedback Device (SFD), EnDat2.2, 01, BiSS, analog Sine/Cos encoder, incremental encoder, HIPERFACE®, and resolver
  - Tightly integrated Ethernet motion buses without the need to add large hardware: EtherCAT®, SynqNet®, Modbus/TCP, and CANopen®
  - Scalable programmability from base torque-and-velocity through multi-axis master

# AKD Servo Drive

The AKD servo drive delivers cutting-edge technology and performance with one of the most compact footprints in the industry. These feature-rich drives provide a solution for nearly any application, from basic torque-and-velocity applications, to indexing, to multi-axis programmable motion with embedded Kollmorgen Automation Suite™. The versatile AKD sets the standard for power density and performance.



KBM™ Frameless Motors



Micron™ Gearheads

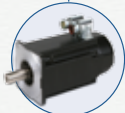

AKM™ Servomotors



Cartridge Direct Drive Rotary™ Motors



Housed Direct Drive Rotary Motors



Direct Drive Linear Motors



Linear Positioners



Multi-Axis Precision Tables

### Best-in-Class Components

AKD works seamlessly with Kollmorgen motors and positioners – well-known for quality, reliability, and performance.



AKD™ Servo Drive



Industry-leading power density

### General Specifications

120 / 240 Vac 1 & 3Ø (85 -265 V)	Continuous Current (Arms)	Peak Current (Arms)	Drive Continuous Output Power Capacity (Watts)	Internal Regen		Height mm (in)	Width mm (in)	Depth mm (in)	Depth with Cable Bend Radius mm (in)
				(Watts)	(Ohms)				
AKD-■00306	3	9	1100	0	0	168 (6.61)	57 (2.24)	153 (6.02)	184 (7.24)
AKD-■00606	6	18	2000	0	0	168 (6.61)	57 (2.24)	153 (6.02)	184 (7.24)
AKD-■01206	12	30	4000	100	15	195 (7.68)	76 (2.99)	186 (7.32)	215 (8.46)
AKD-■02406	24	48	8000	200	8	250 (9.84)	100 (3.94)	230 (9.06)	265 (10.43)
480 Vac 3Ø (342 -528 V)	Continuous Current (Arms)	Peak Current (Arms)	Drive Continuous Output Power Capacity (Watts)	Internal Regen		Height mm (in)	Width mm (in)	Depth mm (in)	Depth with Cable Bend Radius mm (in)
				(Watts)	(Ohms)				
AKD-■00307	3	9	2000	100	33	256 (10.08)	70 (2.76)	186 (7.32)	221 (8.70)
AKD-■00607	6	18	4000	100	33	256 (10.08)	70 (2.76)	186 (7.32)	221 (8.70)
AKD-■01207	12	30	8000	100	33	256 (10.08)	70 (2.76)	186 (7.32)	221 (8.70)
AKD-■02407	24	48	16,000	200	23	310 (12.20)	105 (4.13)	229 (9.02)	264 (10.39)
AKD-■04807	48	96	32,000	400		<i>Coming Soon</i>			
AKD-■09607	96	192	64,000	800		<i>Coming Soon</i>			

Note: For complete AKD model nomenclature, refer to page 34.

# Co-Engineering Capabilities

Because Kollmorgen offers the highest quality and broadest range of best-in-class motion components, we can supply standard, modified or customized solutions to meet any application need.

We have co-engineer solutions to meet your most difficult challenges and advance your competitive position. Drawing on a wealth of knowledge and expertise, our engineering support team will work alongside with you to build a solution that differentiates your machine and improves your bottom line.

Here are just few examples of how Kollmorgen delivers real value to companies likes yours:

What You Need	Why Motion Matters	Kollmorgen Co-Engineering Results
30% Increase in Throughput	<ul style="list-style-type: none"><li>• Low inertia servomotors</li><li>• High bandwidth servo loops</li><li>• Simple, accurate, graphical programming tools</li></ul>	Using Kollmorgen Automation Suite™'s graphical camming design tool, Pipe Network™ and low-inertia AKM motors, a major supplier of medical equipment <b>increased throughput by more than 30%</b> while improving accuracy and reducing scrap.
50% Increase in Accuracy and Quality	<ul style="list-style-type: none"><li>• Low cogging servomotors</li><li>• Advanced observers and bi-quad filters</li><li>• Fast control loop update rates (.67µs)</li></ul>	Using or AKD™, a next-generation CT scanning manufacturer achieved <b>more than 50% improvement in velocity ripple</b> to produce the most accurate and detailed medical images possible while overcoming an extremely high moment of inertia.
25% Increase in Reliability (Overall Equipment Effectiveness)	<ul style="list-style-type: none"><li>• Innovative Cartridge DDR™</li><li>• Eliminating parts on the machine</li><li>• No additional wearing components</li></ul>	Using Kollmorgen's award-winning Cartridge DDR™ servomotor technology, we eliminated more than 60 parts in a die-cutting machine and <b>increased the OEE by 25%</b> and throughput by 20%.
50% Reduction in Waste	<ul style="list-style-type: none"><li>• Superior motor/drive system bandwidth</li><li>• DDR technology:<ul style="list-style-type: none"><li>– eliminates gearbox</li><li>– 20X more accurate than geared solution</li></ul></li></ul>	We helped a manufacturer of pharmaceutical packaging machines incorporate Housed DDR motors to increase the throughput by 35% and <b>reduce scrap by more than 50%</b> through more accurate alignment of the capsules.

# Housed DDR Motor System Summary

		Performance Chart Page	AKD Servo Drive			Performance					
			AKD- ■0060X	AKD- ■0120X	AKD- ■0240X	Continuous Torque <sup>1</sup>		Peak Torque		Maximum Speed	
						Nm	lb-ft	Nm	lb-ft	RPM	
<b>Housed DDR Motors</b>	<b>240 Volt Systems</b>	D061	16	x		5.3	3.9	16.9	12.5	500	
		D062	16	x		9.8	7.2	33.5	24.7	500	
		D063	16	x		17.7	13.1	64.4	47.5	500	
		D081	20	x		15.9	11.7	45.0	33.2	500	
		D082	20	x		25.9	19.1	92.2	68.0	300	
		D083	20	x		50.4	37.2	160	118	250	
		D101	24	x		34.6	25.5	129	95.0	300	
		D102	24	x		63.4	46.7	227	167	200	
		D103	24		x	115	85.0	501	370	120	
		D141	28		x	108	80.0	367	271	200	
		D142	28		x	183	135	519	383	120	
		D143	28			x	339	250	1341	989	60
			<b>400 / 480 Volt Systems</b>	DH061	17	x		5.3	3.9	16.9	12.5
DH062	17			x		9.8	7.2	33.5	24.7	800	
DH063	17			x		17.7	13.1	64.4	47.5	800	
DH081	21			x		15.9	11.7	45.0	33.2	500	
DH082	21			x		25.9	19.1	92.2	68.0	500	
DH083	21			x		50.4	37.2	160	118	500	
DH101	25			x		34.6	25.5	129	95.0	300	
DH102	25			x		63.4	46.7	227	167	300	
DH103	25				x	115	85.0	501	370	250	
DH141	29				x	108	80.0	367	271	300	
DH142	29				x	183	135	519	383	300	
DH143	29					x	339	250	1341	989	120

Note 1: Continuous torque with sine encoder feedback. For continuous torque with resolver feedback, see the Performance Data Table.

## Motor Outside / Inside Diameters by Model

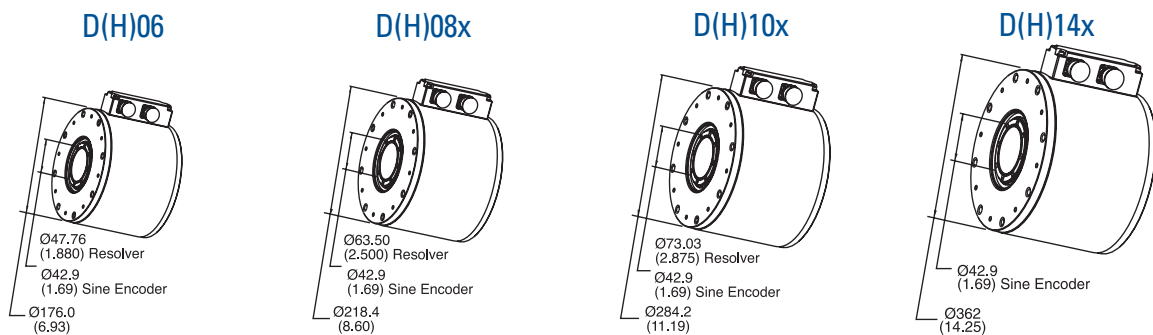

# Housed DDR D06X Performance Data

## 230 VAC

System Performance:		Symbols	Units	D061A/D061M	D062A/D062M	D063A/D063M
Peak Torque		T <sub>p</sub>	lb-ft (N-m)	12.5 (16.9)	24.7 (33.5)	47.5 (64.4)
Continuous <sup>1</sup> Torque 40°C	Sine Encoder	T <sub>c</sub>	lb-ft (N-m)	3.9 (5.3)	7.2 (9.8)	13.1 (17.7)
	Resolver	T <sub>c</sub>	lb-ft (N-m)	4.3 (5.8)	8.0 (10.8)	14.5 (19.7)
Max. Operating Speed		N max	rpm (rps)	500 (8.3)	500 (8.3)	500 (8.3)
Sine Encoder System	Resolution	-	counts/rev	134,217,728	134,217,728	134,217,728
	Repeatability	-	arc/sec	< 1	< 1	< 1
	Accuracy	-	arc/sec	±26	±26	±26
Resolver System	Resolution	-	counts/rev	134,217,728	134,217,728	134,217,728
	Repeatability	-	arc/sec	±2.4	±2.4	±2.4
	Accuracy	-	arc/sec	±270	±270	±270
<b>Mechanical:</b>						
Weight		W <sub>t</sub>	lb kg	20.8 (9.4)	25.0 (11.3)	30.5 (13.8)
Rotor Inertia		J <sub>m</sub>	lb-ft-sec <sup>2</sup> (kg-m <sup>2</sup> )	0.0045 (0.0061)	0.0052 (0.0071)	0.0064 (0.0086)
Static Friction Adder for Sealed Units		T <sub>f</sub>	lb-ft (N-m)	1.8 (2.4)	1.8 (2.4)	1.8 (2.4)
Max. Dynamic Axle Compression Load (See page 33 for Details)		-	lbf (kg)	4,500 (2,040)	4,500 (2,040)	4,500 (2,040)

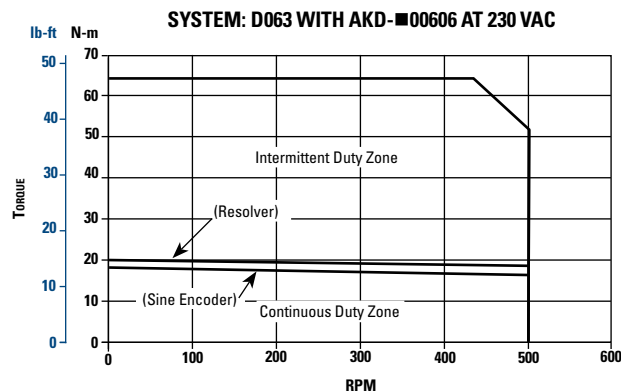
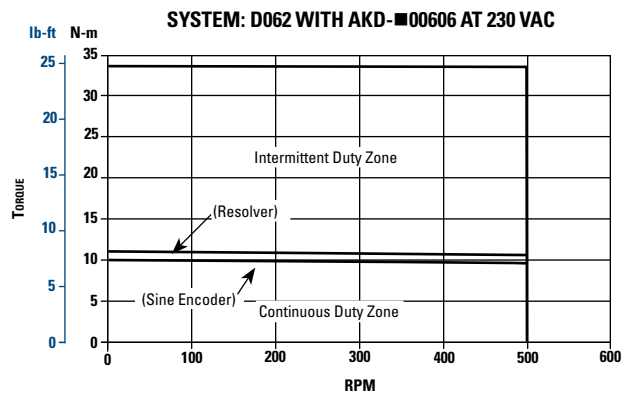
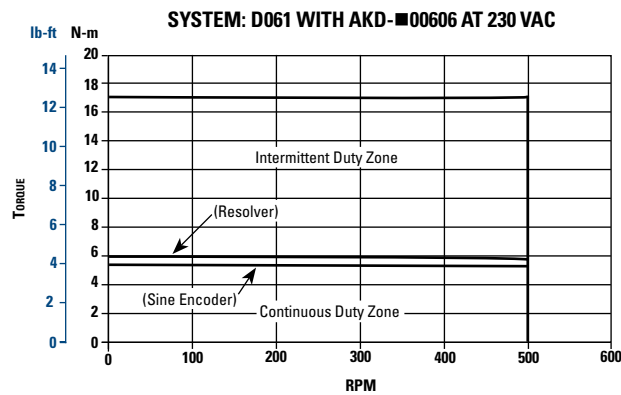

**Notes:**

1. For 25°C ambient, multiply T<sub>c</sub> by 1.06.
2. Curves for 230 V applicable to single or three phase input power.



# Housed DDR DH06X Performance Data

## 400/480 VAC

System Performance:		Symbols	Units	DH061A/DH061M	DH062A/DH062M	DH063A/DH063M
Peak Torque		Tp	lb-ft (N-m)	12.5 (16.9)	24.7 (32.8)	47.5 (64.4)
Continuous <sup>1</sup> Torque 40°C	Sine Encoder	Tc	lb-ft (N-m)	3.9 (5.3)	7.2 (9.8)	13.1 (17.7)
	Resolver	Tc	lb-ft (N-m)	4.3 (5.8)	8.0 (10.8)	14.5 (19.7)
Max. Operating Speed 400/480 V 3 Phase		N max	rpm (rps)	800 (13.3)	800 (13.3)	800 (13.3)
Sine Encoder System	Resolution	-	counts/rev	134,217,728	134,217,728	134,217,728
	Repeatability	-	arc/sec	< 1	< 1	< 1
	Accuracy	-	arc/sec	±26	±26	±26
Resolver System	Resolution	-	counts/rev	134,217,728	134,217,728	134,217,728
	Repeatability	-	arc/sec	±10	±10	±10
	Accuracy	-	arc/sec	±270	±270	±270
<b>Mechanical:</b>						
Weight		Wt	lb (kg)	20.8 (9.4)	25.0 (11.3)	30.5 (13.8)
Rotor Inertia		Jm	lb-ft-sec <sup>2</sup> (kg-m <sup>2</sup> )	0.0045 (0.0061)	0.0052 (0.0071)	0.0064 (0.0086)
Static Friction Adder for Sealed Units		Tf	lb-ft (N-m)	1.8 (2.4)	1.8 (2.4)	1.8 (2.4)
Max. Dynamic Axle Compression Load (See Page 33 For Details)		-	lbf (kg)	4,500 (2,040)	4,500 (2,040)	4,500 (2,040)

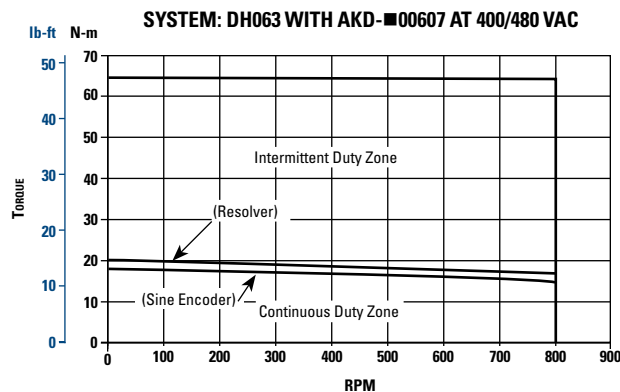
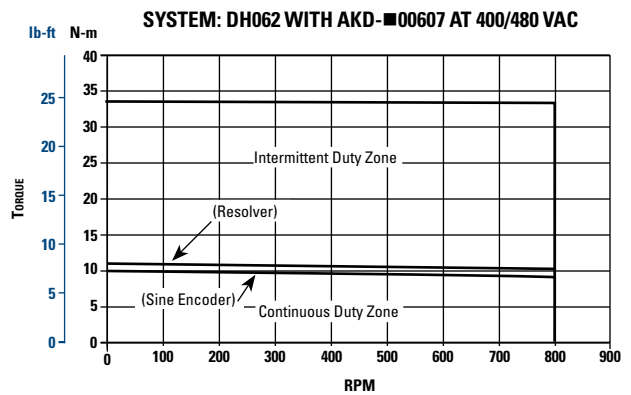
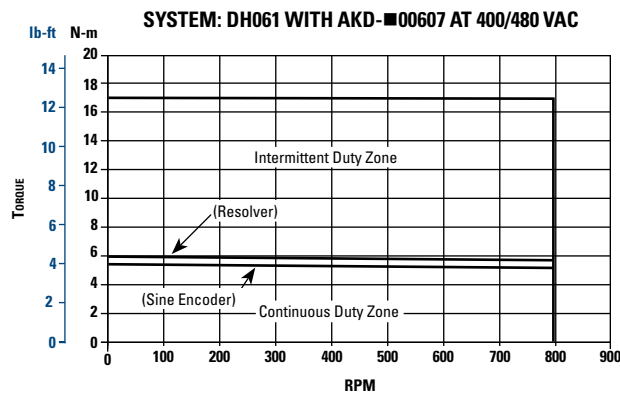

Notes:  
1. For 25°C ambient, multiply by 1.06.

# Housed DDR D06X Outline Drawings

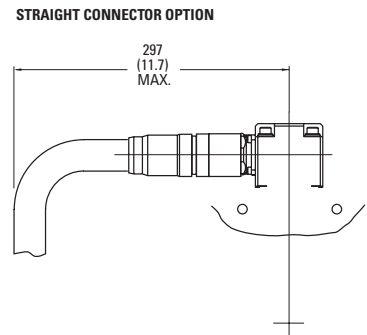
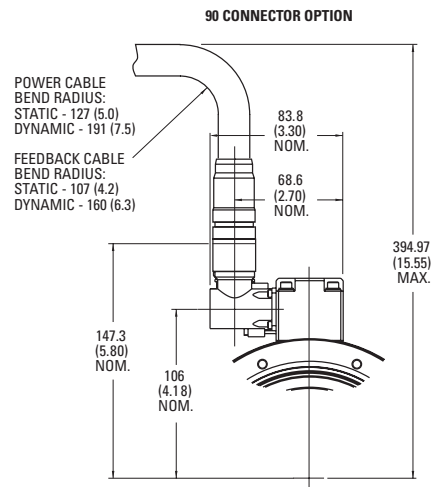
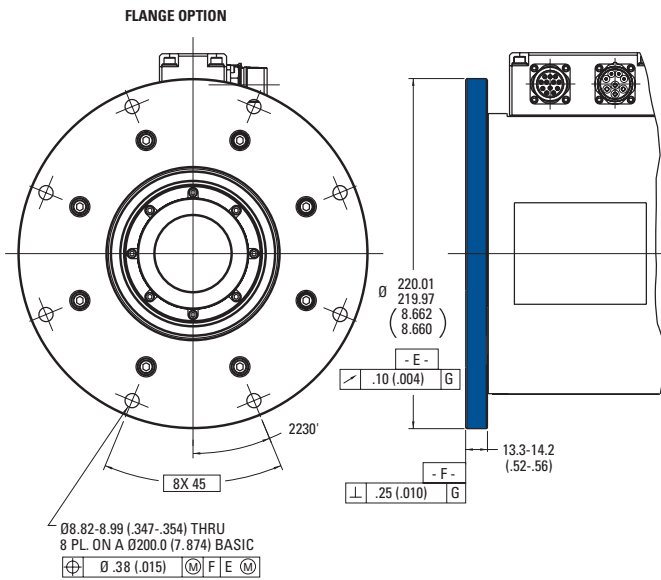
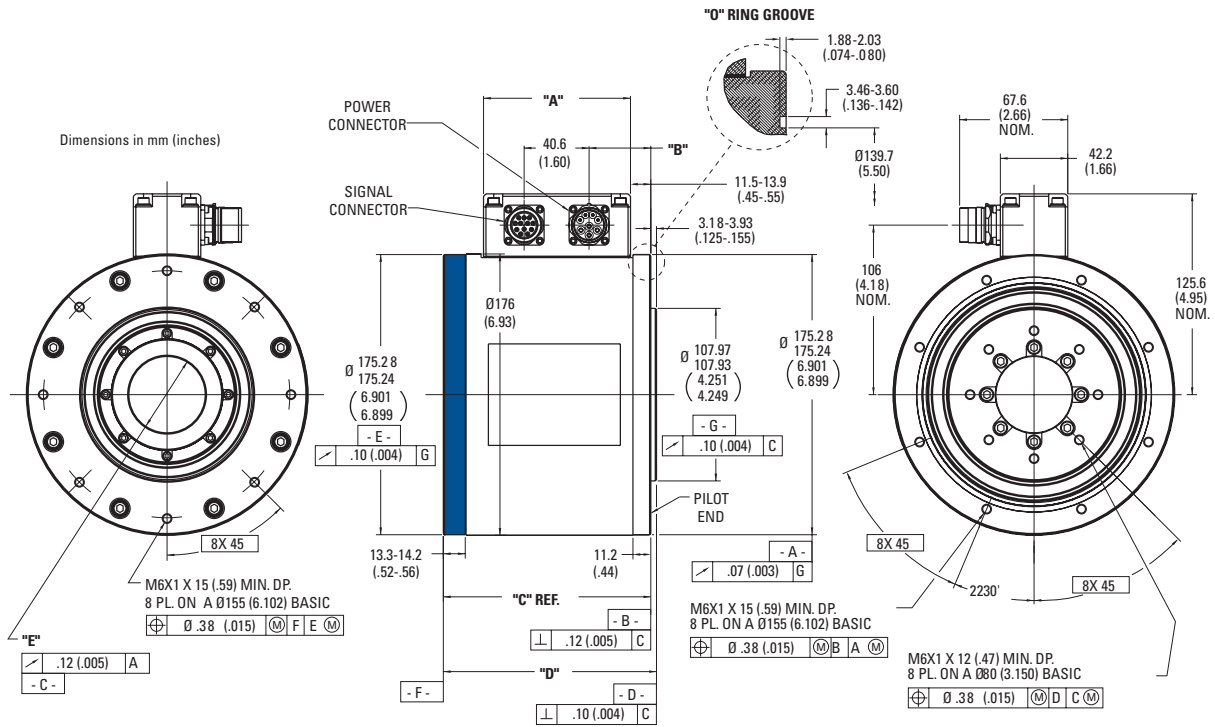

Model	"A"	"B"	"C"	"D"	"E"	
D061	91.9 (3.62)	37.1-40.1 (1.46-1.58)	129.42-130.171 (5.095-5.125)	32.59-134.11 (5.220-5.280)	Resolver	Sine Encoder
D062	103.4 (4.07)	48.6-51.5 (1.91-2.03)	140.85-141.601 (5.545-5.575)	44.02-145.54 (5.660-5.730)	Ø47.71-47.80 (1.878-1.882)	Ø42.88-42.98 (1.688-1.692)
D063	126.2 (4.97)	71.4-74.4 (2.81-2.93)	163.71-164.46 (6.445-6.475)	166.88-168.40 (6.570-6.630)		

Note: Dimensions "C" and "D" increase by 7.90mm (0.311") on sine encoder models with IP65 or IP67 seals.

# Notes

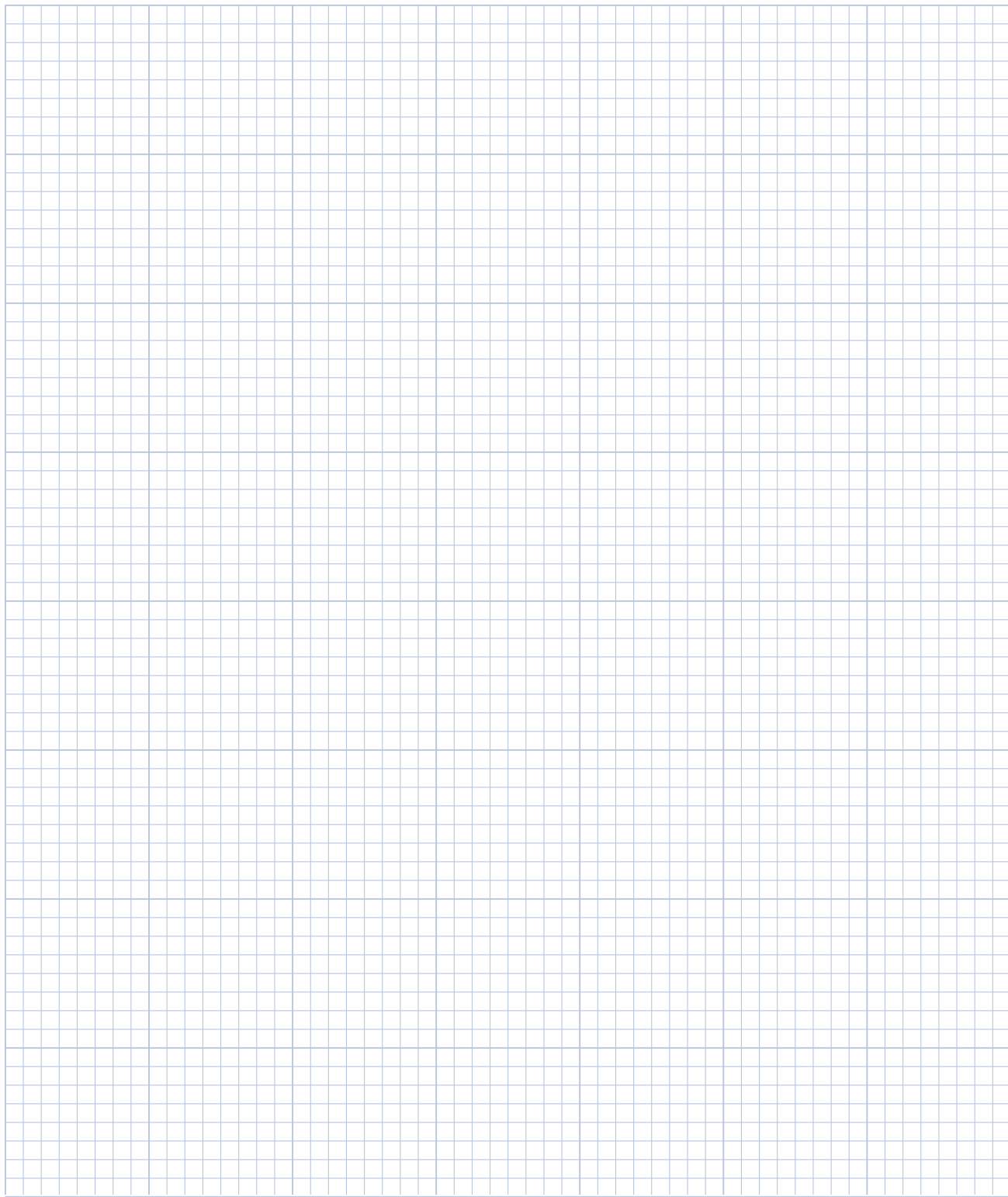

# Housed DDR D08X Performance Data

## 230 VAC

System Performance:		Symbols	Units	D081A/D081M	D082A/D082M	D083A/D083M
Peak Torque		T <sub>p</sub>	lb-ft (N-m)	33.2 (45.0)	68.0 (92.2)	118 (160)
Continuous <sup>1</sup> Torque 40°C	Sine Encoder	T <sub>c</sub>	lb-ft (N-m)	11.7 (15.9)	19.1 (25.9)	37.2 (50.4)
	Resolver	T <sub>c</sub>	lb-ft (N-m)	13.0 (17.6)	21.2 (28.7)	41.3 (56.0)
Max. Operating Speed		N max	rpm (rps)	500 (8.3)	300 (5.0)	250 (4.2)
Sine Encoder System	Resolution	-	counts/rev	134,217,728	134,217,728	134,217,728
	Repeatability	-	arc/sec	< 1	< 1	< 1
	Accuracy	-	arc/sec	±26	±26	±26
Resolver System	Resolution	-	counts/rev	134,217,728	134,217,728	134,217,728
	Repeatability	-	arc/sec	±2.4	±2.4	±2.4
	Accuracy	-	arc/sec	±140	±140	±140
<b>Mechanical:</b>						
Weight		Wt	lb (kg)	39.5 (17.9)	47.5 (21.5)	63.6 (28.8)
Rotor Inertia		J <sub>m</sub>	lb-ft-sec <sup>2</sup> (kg-m <sup>2</sup> )	0.0106 (0.0144)	0.0143 (0.0194)	0.0222 (0.0301)
Static Friction Adder for Sealed Units		T <sub>f</sub>	lb-ft (N-m)	2.0 (2.7)	2.0 (2.7)	2.0 (2.7)
Max. Dynamic Axle Compression Load (See page 33 for details)		-	lbf (kg)	7,400 (3,360)	7,400 (3,360)	7,400 (3,360)

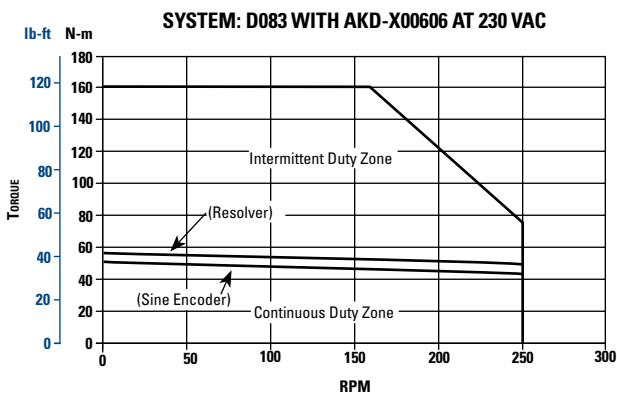
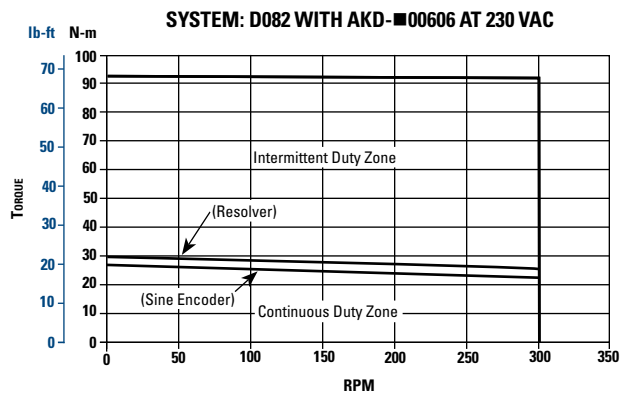
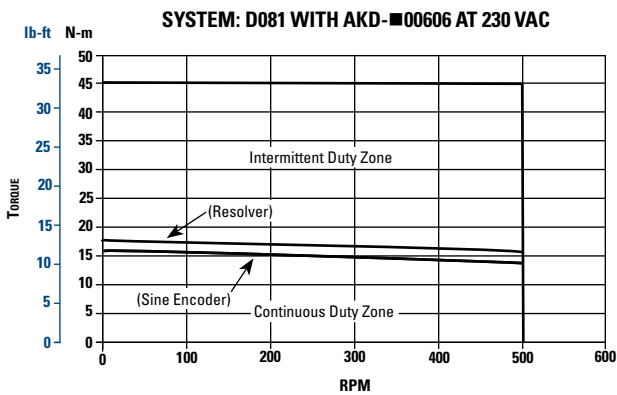

- Notes:
- For 25°C ambient, multiply T<sub>c</sub> by 1.06.
  - Curves for 230 V applicable to single or three phase input power.

# Housed DDR DH08X Performance Data

## 400/480 VAC

System Performance:		Symbols	Units	DH081A/DH081M	DH082A/DH082M	DH083A/DH083M
Peak Torque		Tp	lb-ft (N-m)	33.2 (45.0)	68.0 (92.2)	118 (160)
Continuous <sup>1</sup> Torque 40°C	Sine Encoder	Tc	lb-ft (N-m)	11.7 (15.9)	19.1 (25.9)	37.2 (50.4)
	Resolver	Tc	lb-ft (N-m)	13.0 (17.6)	21.2 (28.7)	41.3 (56.0)
Max. Operating Speed 400/480 V 3 Phase		N max	rpm (rps)	500 (8.3)	500 (8.3)	400/500 (6.7/8.3)
Sine Encoder System	Resolution	-	counts/rev	134,217,728	134,217,728	134,217,728
	Repeatability	-	arc/sec	< 1	< 1	< 1
	Accuracy	-	arc/sec	±26	±26	±26
Resolver System	Resolution	-	counts/rev	134,217,728	134,217,728	134,217,728
	Repeatability	-	arc/sec	±2.4	±2.4	±2.4
	Accuracy	-	arc/sec	±140	±140	±140
<b>Mechanical:</b>						
Weight		Wt	lb (kg)	39.5 (17.9)	47.5 (21.5)	63.6 (28.8)
Rotor Inertia		Jm	lb-ft-sec <sup>2</sup> (kg-m <sup>2</sup> )	0.0106 (0.0144)	0.0143 (0.0194)	0.0222 (0.0301)
Static Friction Adder for Sealed Units		Tf	lb-ft (N-m)	2.0 (2.7)	2.0 (2.7)	2.0 (2.7)
Max. Dynamic Axle Compression Load (See Page 33 for Details)		-	lbf (kg)	7,400 (3,360)	7,400 (3,360)	7,400 (3,360)

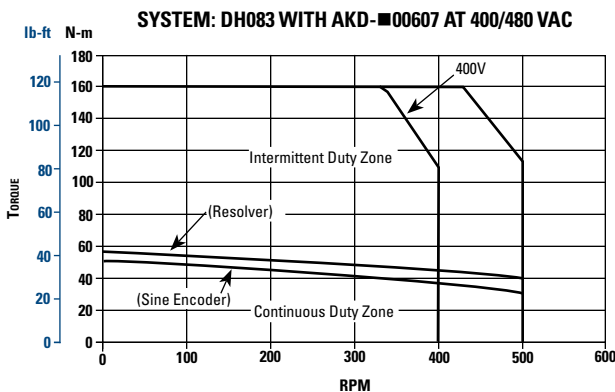
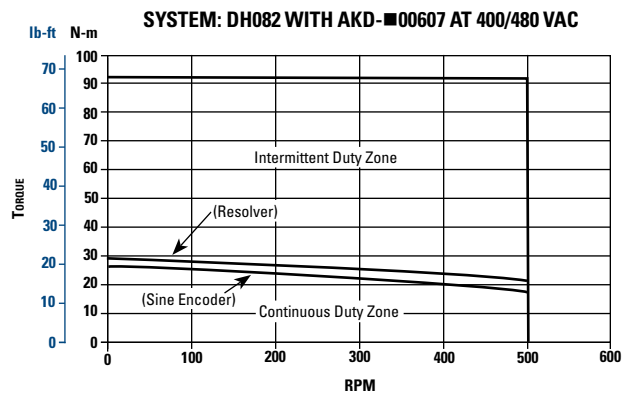
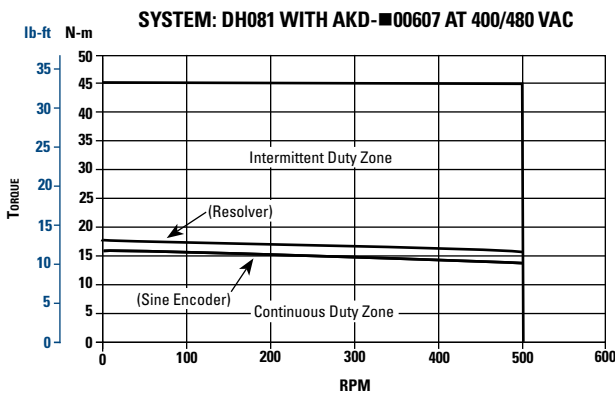

Notes:  
1. For 25°C ambient, multiply by 1.06.

# Housed DDR D08X Outline Drawings

Dimensions in mm (inches)

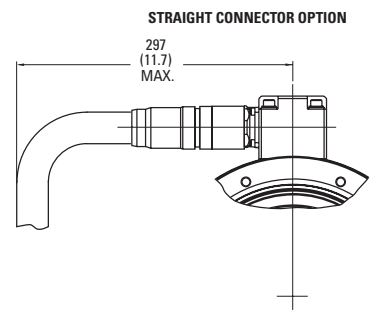
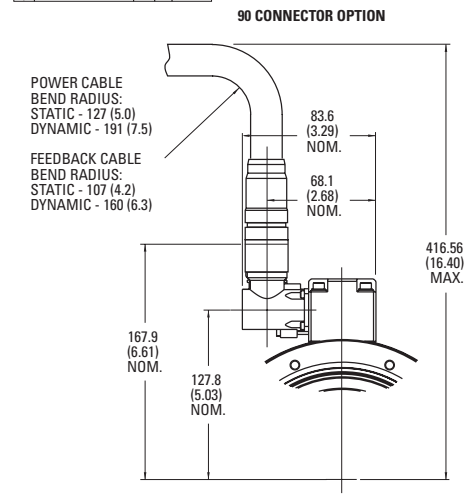
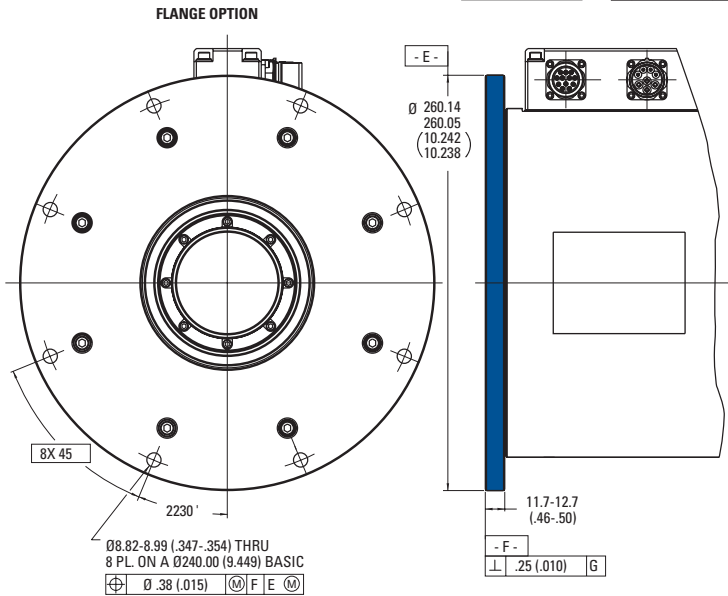
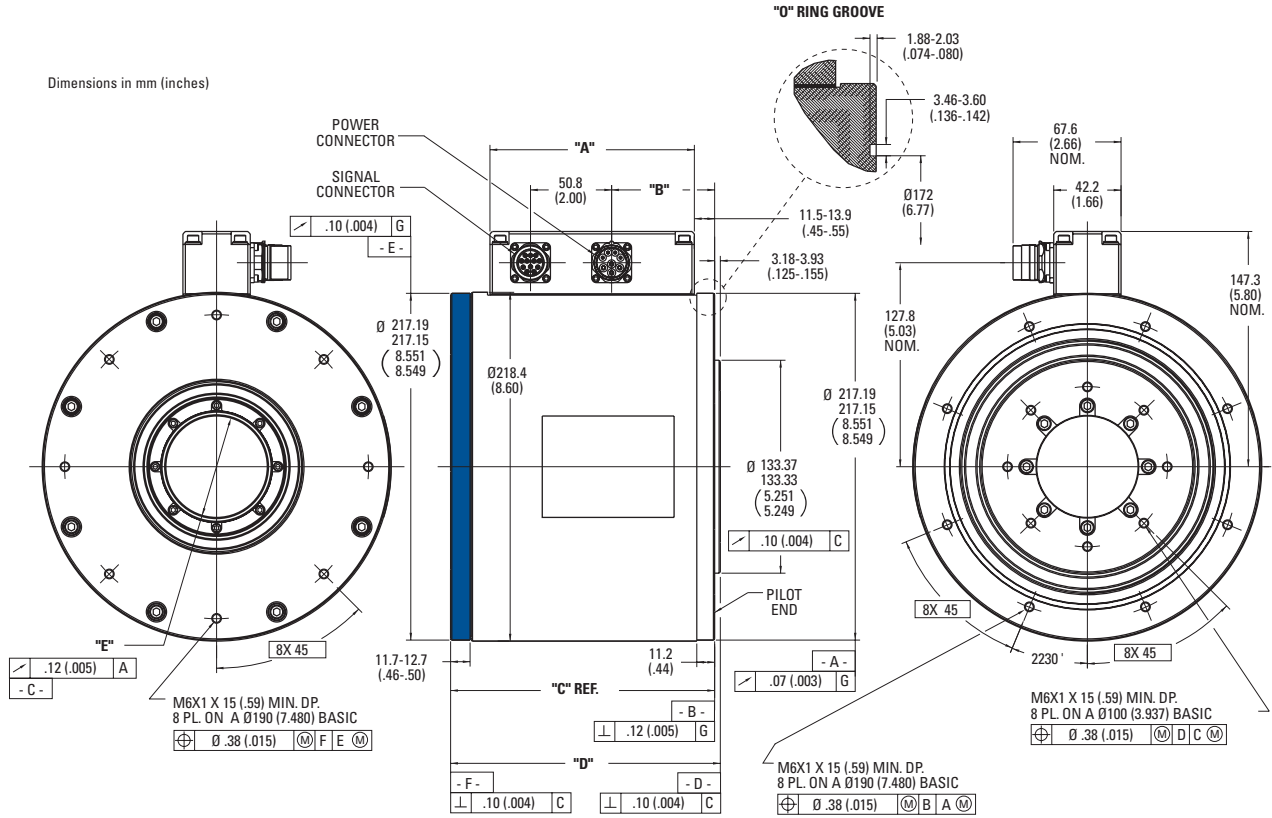

Model	"A"	"B"	"C"	"D"	"E"	
D081	107.7 (4.24)	42.7-45.7 (1.68-1.80)	144.66-145.41 (5.695-5.725)	147.83-149.35 (5.820-5.880)	Resolver	Sine Encoder
D082	128.0 (5.04)	63.0-66.0 (2.48-2.60)	164.98-165.73 (6.495-6.525)	168.15-169.67 (6.620-6.680)	Ø63.45-63.55 (2.498-2.502)	Ø42.88-42.98 (1.688-1.692)
D083	168.7 (6.64)	71.4-74.4 (4.08-4.20)	163.71-164.46 (8.095-8.125)	166.88-168.40 (8.220-8.280)		

Dimensions "C" and "D" increase by 8.64mm (0.340") on sine encoder models with IP65 or IP67 seals.

# Notes

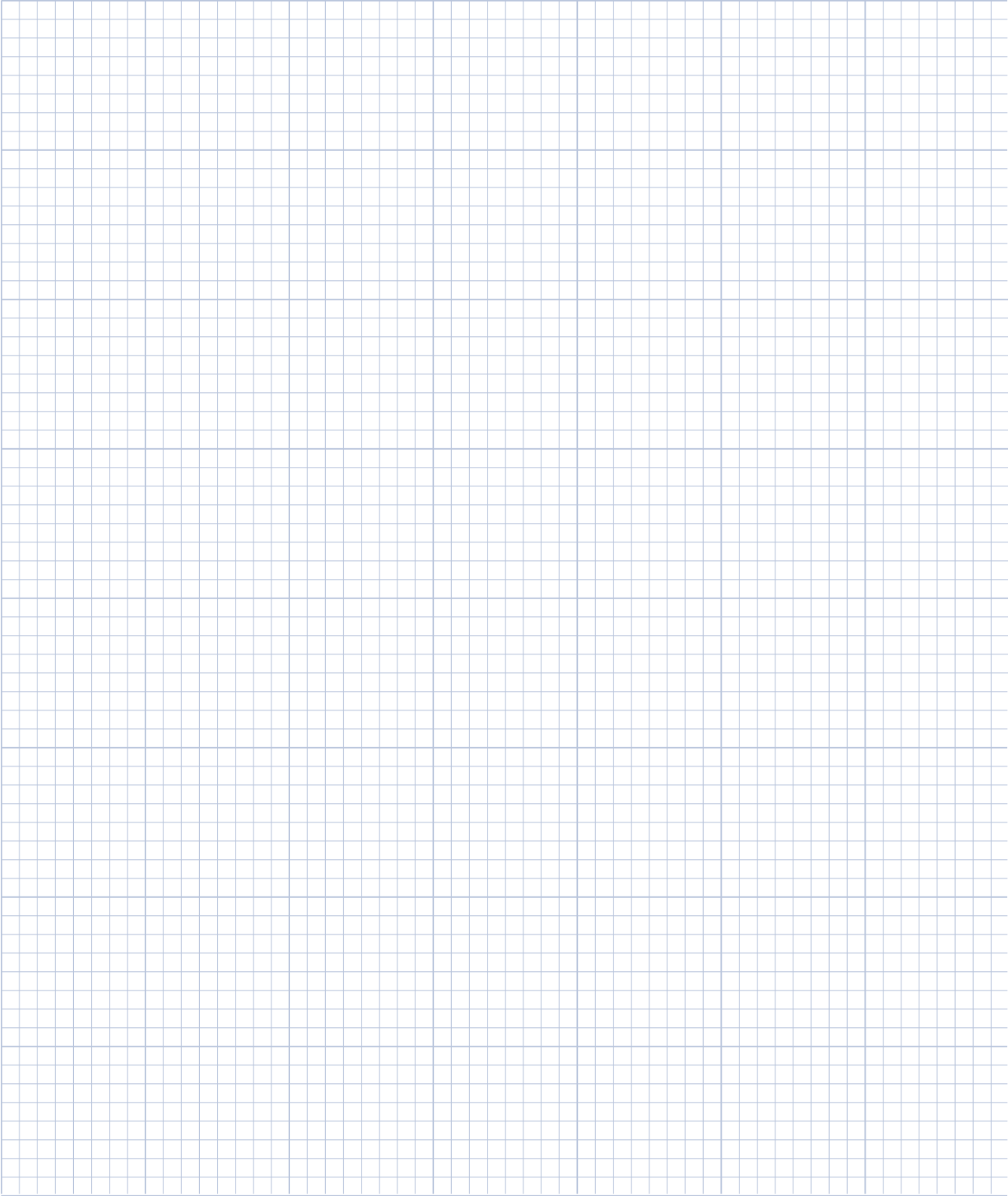

# Housed DDR D10X Performance Data

## 230 VAC

System Performance:		Symbols	Units	D101A/D101M	D102A/D102M	D103A/D103M
Peak Torque		Tp	lb-ft (N-m)	95.0 (129)	167 (227)	370 (501)
Continuous <sup>1</sup> Torque 40°C	Sine Encoder	Tc	lb-ft (N-m)	25.5 (34.6)	46.8 (63.4)	85.0 (115)
	Resolver	Tc	lb-ft (N-m)	30.0 (40.7)	55.0 (74.6)	100 (136)
Max. Operating Speed		N max	rpm (rps)	300 (5.0)	200 (3.3)	120 (2.0)
Sine Encoder System	Resolution	-	counts/rev	134,217,728	134,217,728	134,217,728
	Repeatability	-	arc/sec	< 1	< 1	< 1
	Accuracy	-	arc/sec	±26	±26	±26
Resolver System	Resolution	-	counts/rev	134,217,728	134,217,728	134,217,728
	Repeatability	-	arc/sec	±2.4	±2.4	±2.4
	Accuracy	-	arc/sec	±135	±135	±135
<b>Mechanical:</b>						
Weight		Wt	lb (kg)	69.5 (31.5)	96.5 (43.8)	134 (60.8)
Rotor Inertia		Jm	lb-ft-sec <sup>2</sup> (kg-m <sup>2</sup> )	0.0511 (0.0693)	0.0732 (0.0992)	0.129 (0.175)
Static Friction Adder for Sealed Units		Tf	lb-ft (N-m)	2.6 (3.5)	2.6 (3.5)	2.6 (3.5)
Max. Dynamic Axle Compression Load (See Page 33 for Details)		-	lbf (kg)	11,700 (5,300)	11,700 (5,300)	11,700 (5,300)

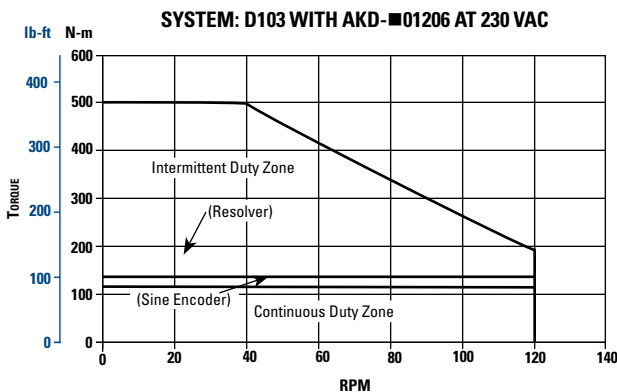
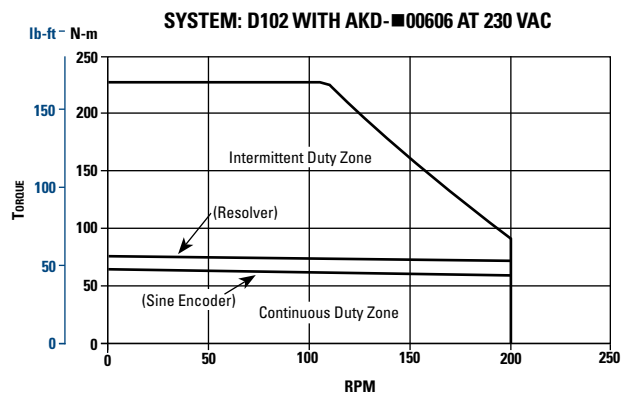
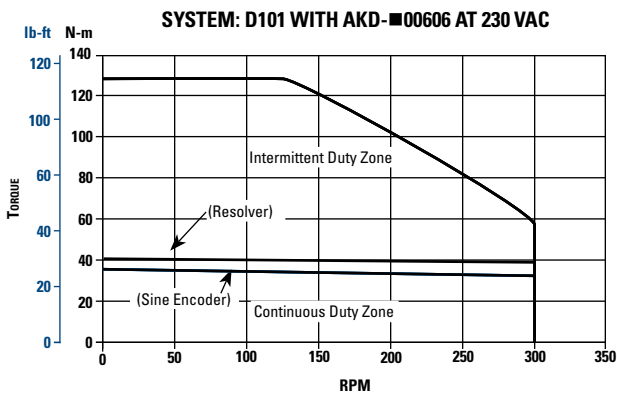

- Notes:
- For 25°C ambient, multiply Tc by 1.06.
  - Curves for 230 V applicable to single or three phase input power.



# Housed DDR DH10X Performance Data

## 400/480 VAC

System Performance:		Symbols	Units	DH101A/DH101M	DH102A/DH102M	DH103A/DH103M
Peak Torque		T <sub>p</sub>	lb-ft (N-m)	95.0 (129)	167 (227)	370 (501)
Continuous <sup>1</sup> Torque 40°C	Sine Encoder	T <sub>c</sub>	lb-ft (N-m)	25.5 (34.6)	46.8 (63.4)	85.0 (115)
	Resolver	T <sub>c</sub>	lb-ft (N-m)	30.0 (40.7)	55.0 (74.6)	100 (136)
Max. Operating Speed 400/480 V 3 Phase		N max	rpm (rps)	300 (5.0/5.0)	300 (5.0/5.0)	200/250 (3.3/4.3)
Sine Encoder System	Resolution	-	counts/rev	134,217,728	134,217,728	134,217,728
	Repeatability	-	arc/sec	< 1	< 1	< 1
	Accuracy	-	arc/sec	±26	±26	±26
Resolver System	Resolution	-	counts/rev	134,217,728	134,217,728	134,217,728
	Repeatability	-	arc/sec	±2.4	±2.4	±2.4
	Accuracy	-	arc/sec	±135	±135	±135
<b>Mechanical:</b>						
Weight		W <sub>t</sub>	lb (kg)	69.5 (31.5)	96.5 (43.8)	134 (60.8)
Rotor Inertia		J <sub>m</sub>	lb-ft-sec <sup>2</sup> (kg-m <sup>2</sup> )	0.0511 (0.0693)	0.0732 (0.0992)	0.129 (0.175)
Static Friction Adder For Sealed Units		T <sub>f</sub>	lb-ft (N-m)	2.6 (3.5)	2.6 (3.5)	2.6 (3.5)
Max. Dynamic Axle Compression Load (See Page 33 For Details)		-	lbf (kg)	11,700 (5,300)	11,700 (5,300)	11,700 (5,300)

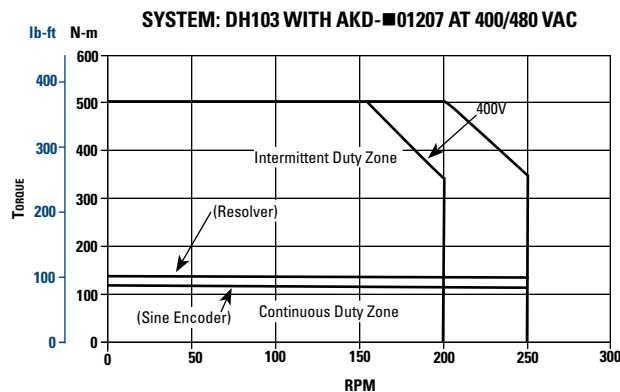
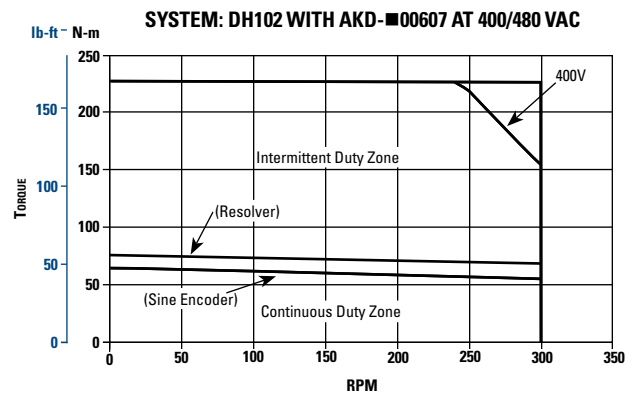
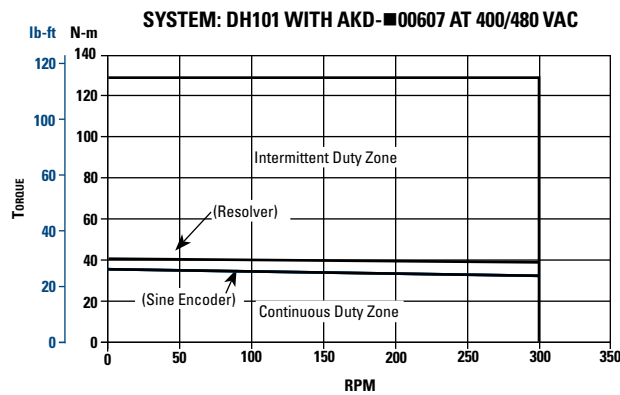

Notes:  
1. For 25°C ambient, multiply by 1.06.

# Housed DDR D10X Outline Drawings

Dimensions in mm (inches)

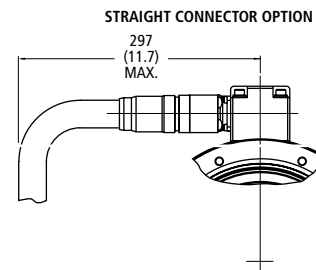
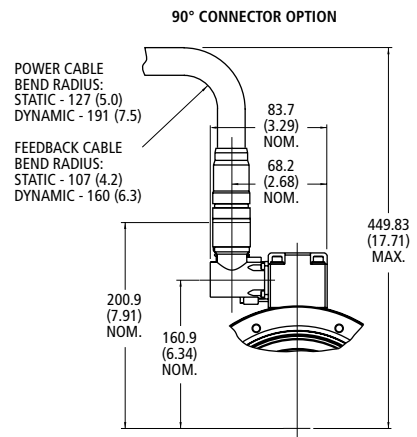
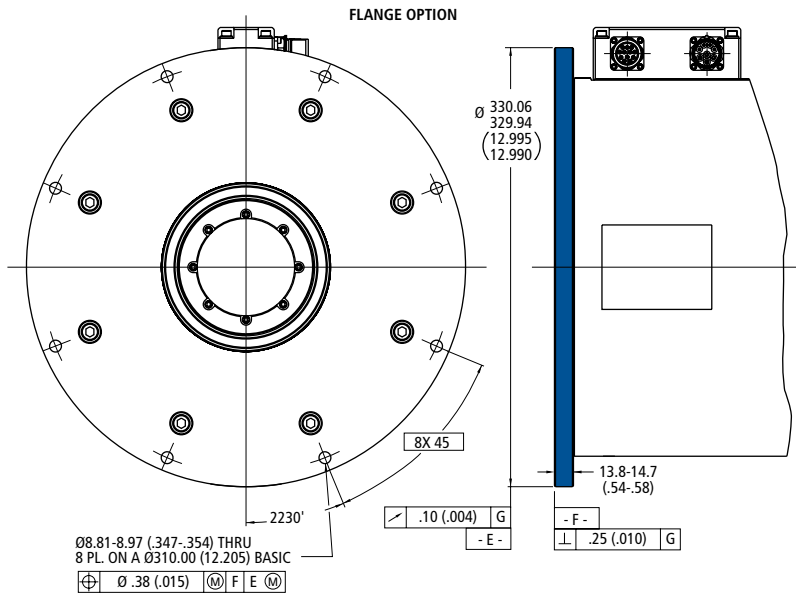
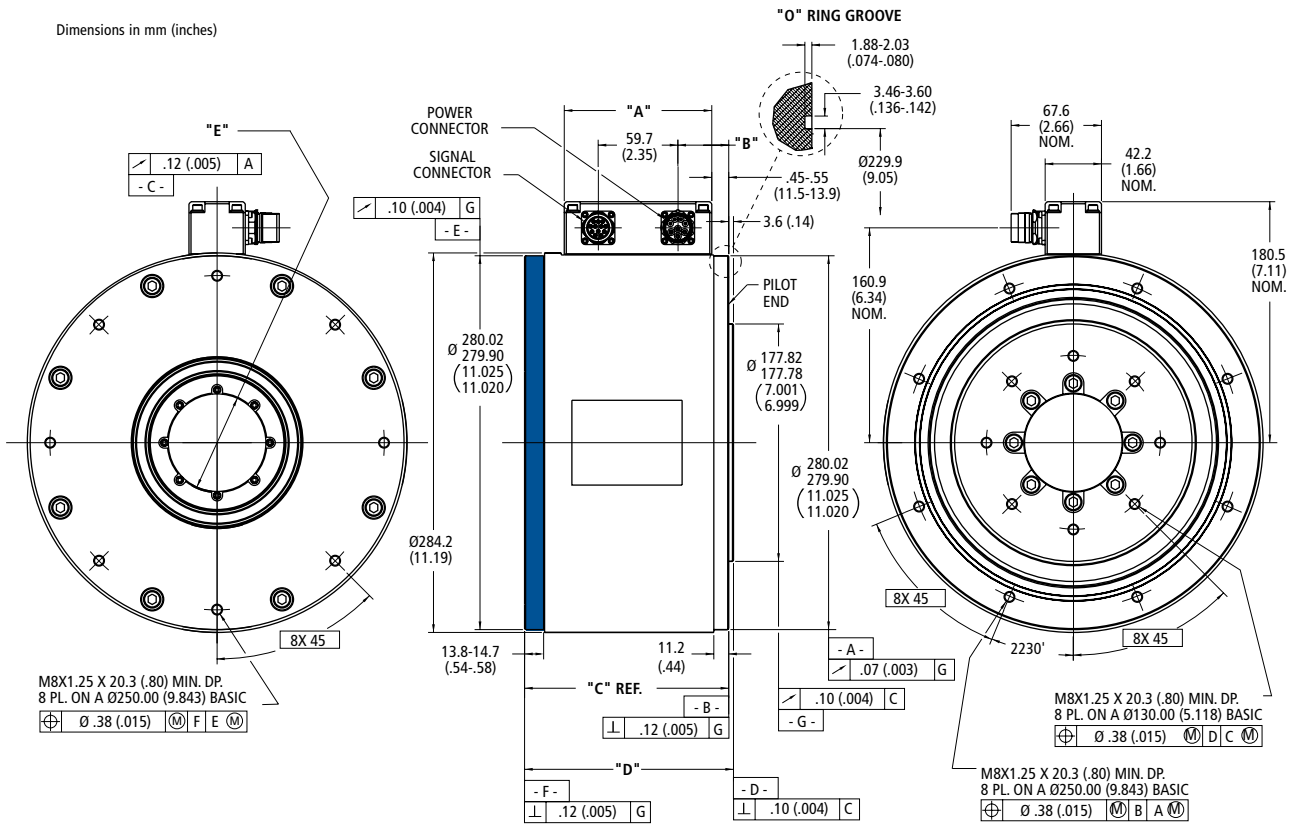

Model	"A"	"B"	"C"	"D"	"E"	
D101	110.5 (4.35)	36.6-39.6 (1.44-1.56)	152.53-153.28 (6.005-6.035)	155.71-157.22 (6.130-6.190)	Resolver	Sine Encoder
D102	142.2 (5.60)	68.4-71.3 (2.69-2.81)	184.28-185.03 (7.255-7.285)	187.46-188.97 (7.380-7.440)	Ø73.07-72.98 (2.877-2.873)	Ø42.88-42.98 (1.688-1.692)
D103	205.7 (8.10)	131.9-134.8 (5.19-5.31)	247.78-248.53 (9.755-9.785)	250.96-252.47 (9.880-9.940)		

Note: Dimensions "C" and "D" increase by 7.57mm (0.298") on sine encoder models with IP65 or IP67 seals.

# Notes

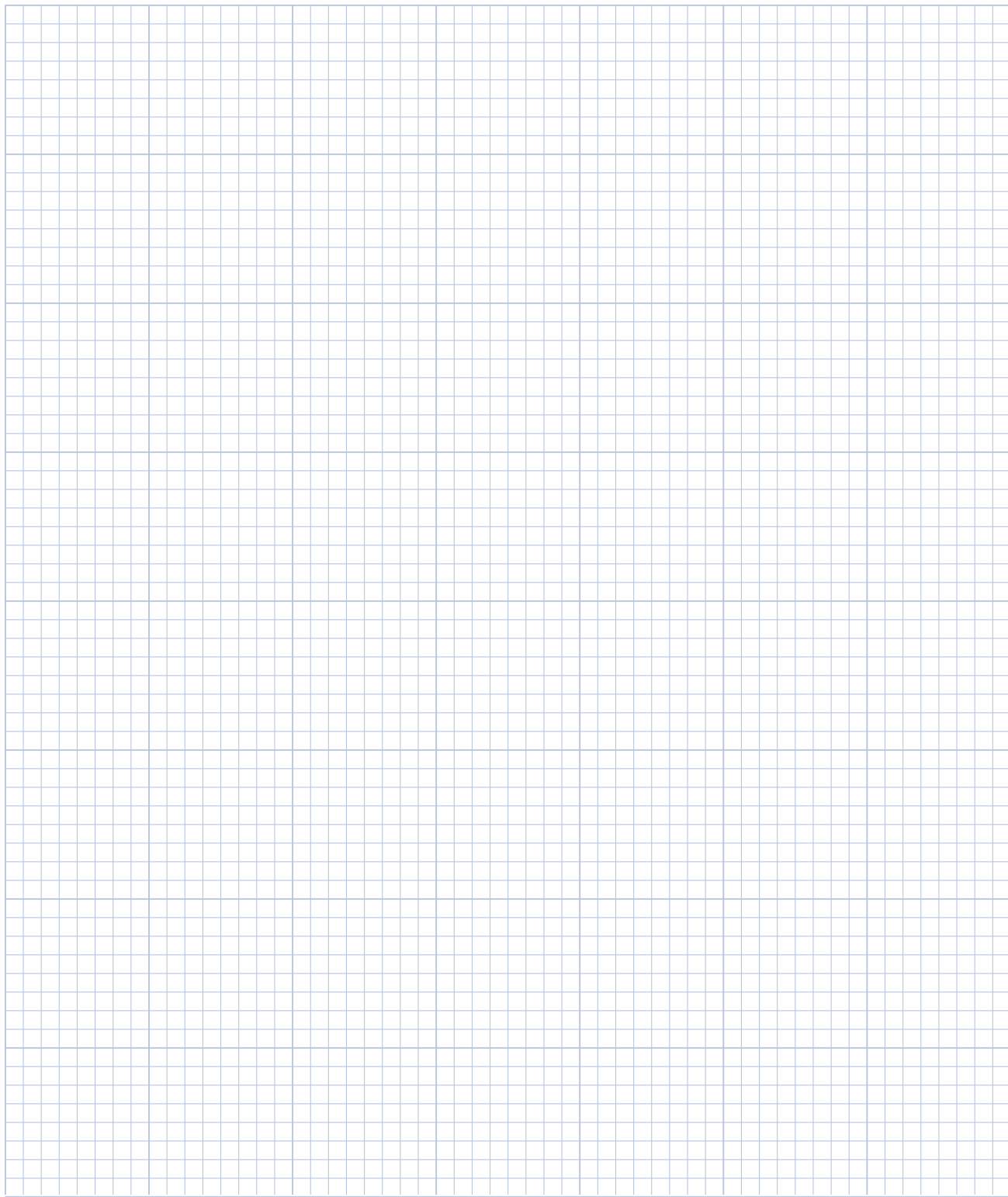

# Housed DDR D14X Performance Data

HOUSED DDR D14X PERFORMANCE DATA

## 230 VAC

System Performance:		Symbols	Units	D141M	D142M	D143M
Peak Torque		$T_p$	lb-ft (N-m)	271 (367)	383 (519)	989 (1341)
Continuous <sup>1</sup> Torque 40°C	Sine Encoder	$T_c$	lb-ft (N-m)	80.0 (108)	135 (183)	250 (339)
Max. Operating Speed		N max	rpm (rps)	200 (3.3)	120 (2.0)	60 (1.0)
Sine Encoder System	Resolution	-	counts/rev	134,217,728	134,217,728	134,217,728
	Repeatability	-	arc/sec	< 1	< 1	< 1
	Accuracy	-	arc/sec	±26	±26	±26
<b>Mechanical:</b>						
Weight		Wt	lb kg	131 (59.4)	191 (86.6)	323 (146)
Rotor Inertia		Jm	lb-ft-sec <sup>2</sup> (kg-m <sup>2</sup> )	0.120 (0.163)	0.202 (0.274)	0.400 (0.542)
Static Friction Adder for Sealed Units		Tf	lb-ft (N-m)	2.6 (3.5)	2.6 (3.5)	2.6 (3.5)
Max. Dynamic Axle Compression Load (See Page 33 for Details)		-	lbf (kg)	12,700 (5,760)	12,700 (5,760)	12,700 (5,760)

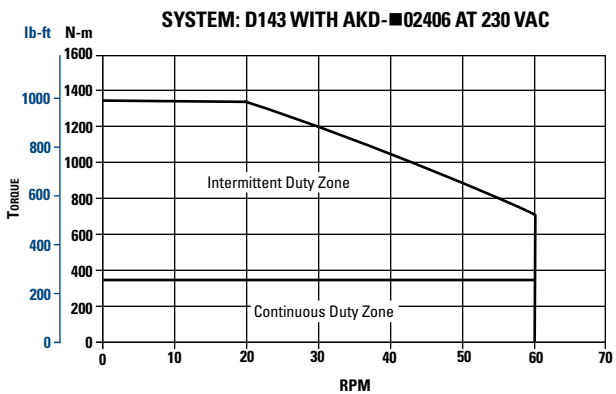
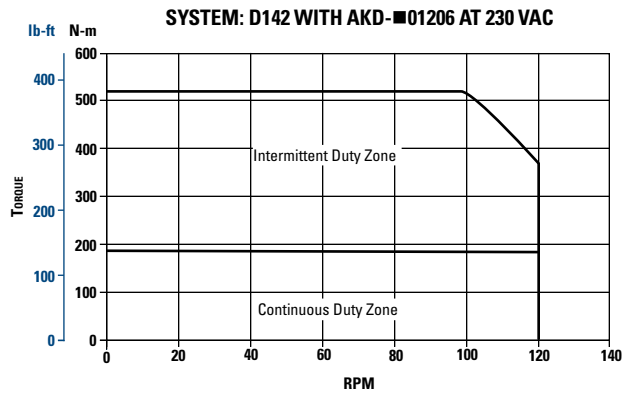
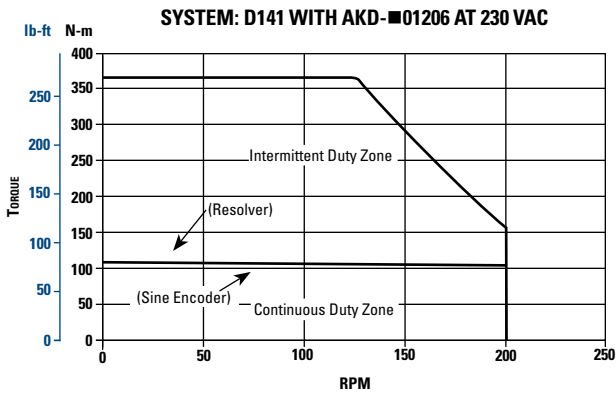

Notes:  
1. For 25°C ambient, multiply by 1.06.

# Housed DDR DH14X Performance Data

## 400/480 VAC

System Performance:		Symbols	Units	DH141M	DH142M	DH143M
Peak Torque		$T_p$	lb-ft (N-m)	271 (367)	383 (519)	989 (1341)
Continuous <sup>1</sup> Torque 40°C	Sine Encoder	$T_c$	lb-ft (N-m)	80.0 (108)	135 (183)	250 (339)
Max. Operating Speed 400/480 V 3 Phase		$N_{max}$	rpm (rps)	300 (5)	250/300 (4.2/5)	120 (2)
Sine Encoder System	Resolution	-	counts/rev	134,217,728	134,217,728	134,217,728
	Repeatability	-	arc/sec	< 1	< 1	< 1
	Accuracy	-	arc/sec	±26	±26	±26
<b>Mechanical:</b>						
Weight		$W_t$	lb (kg)	131 (59.4)	191 (86.6)	323 (146)
Rotor Inertia		$J_m$	lb-ft-sec <sup>2</sup> (kg-m <sup>2</sup> )	0.120 (0.163)	0.202 (0.274)	0.400 (0.542)
Static Friction Adder for Sealed Units		$T_f$	lb-ft (N-m)	2.6 (3.5)	2.6 (3.5)	2.6 (3.5)
Max. Dynamic Axle Compression Load (See Page 33 for Details)		-	lbf (kg)	12,700 (5,760)	12,700 (5,760)	12,700 (5,760)

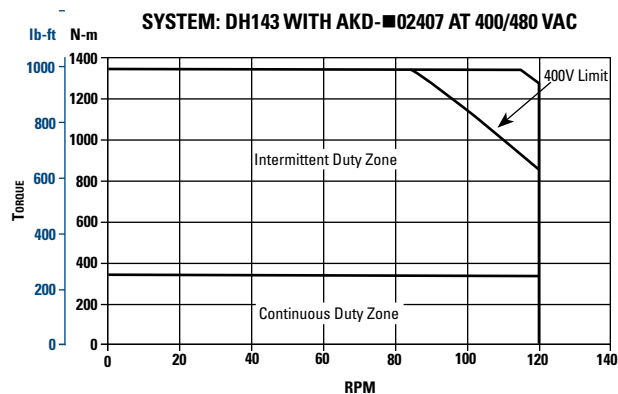
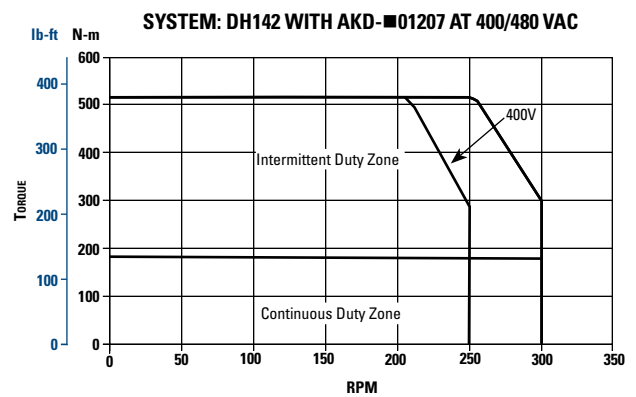
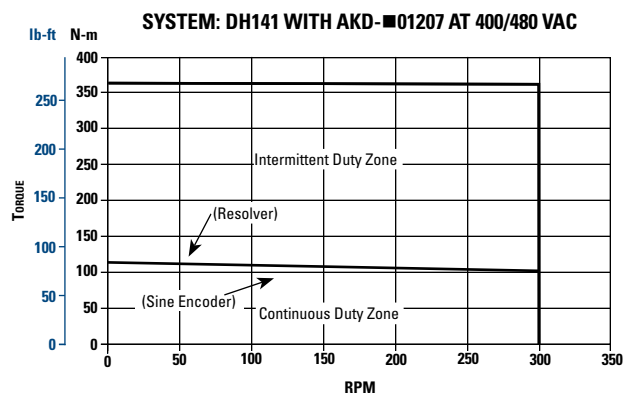

Notes:  
1. For 25°C ambient, multiply by 1.06.

# Housed DDR D14X Outline Drawings

HOUSED DDR D14X OUTLINE DRAWINGS

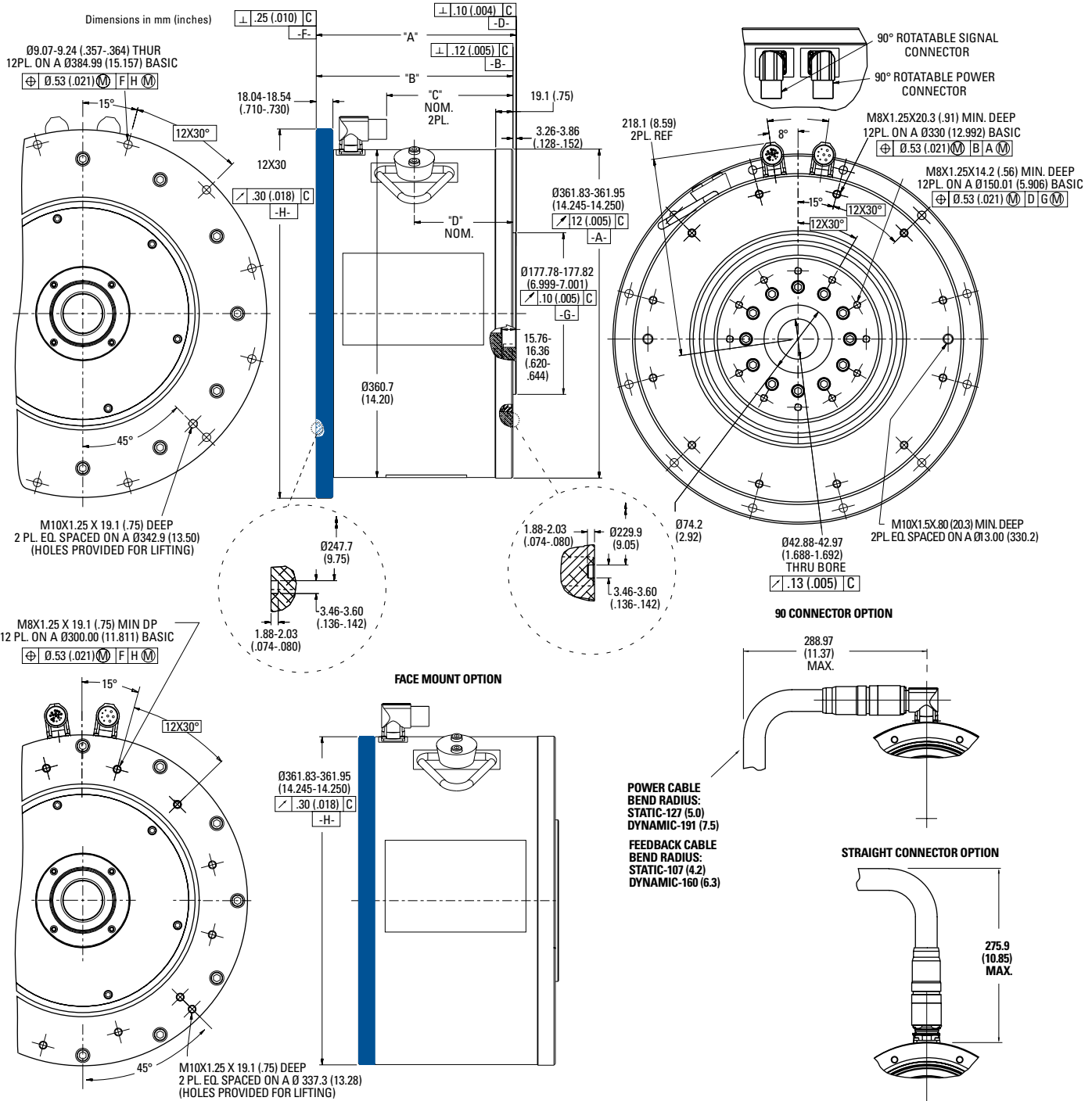

Model	"A"	"B"	"C"	"D"
D141	155.92-157.02 (6.138-6.182)	152.66-153.16 (6.010-6.030)	75.5 (2.97)	76.7 (3.02)
D142	219.42-220.52 (8.638-8.682)	216.16-216.66 (8.510-8.530)	138.9 (5.47)	108.5 (4.27)
D143	346.42-347.52 (13.638-13.682)	343.16-343.66 (13.510-13.530)	266.0 (10.47)	172.0 (6.77)

# Notes

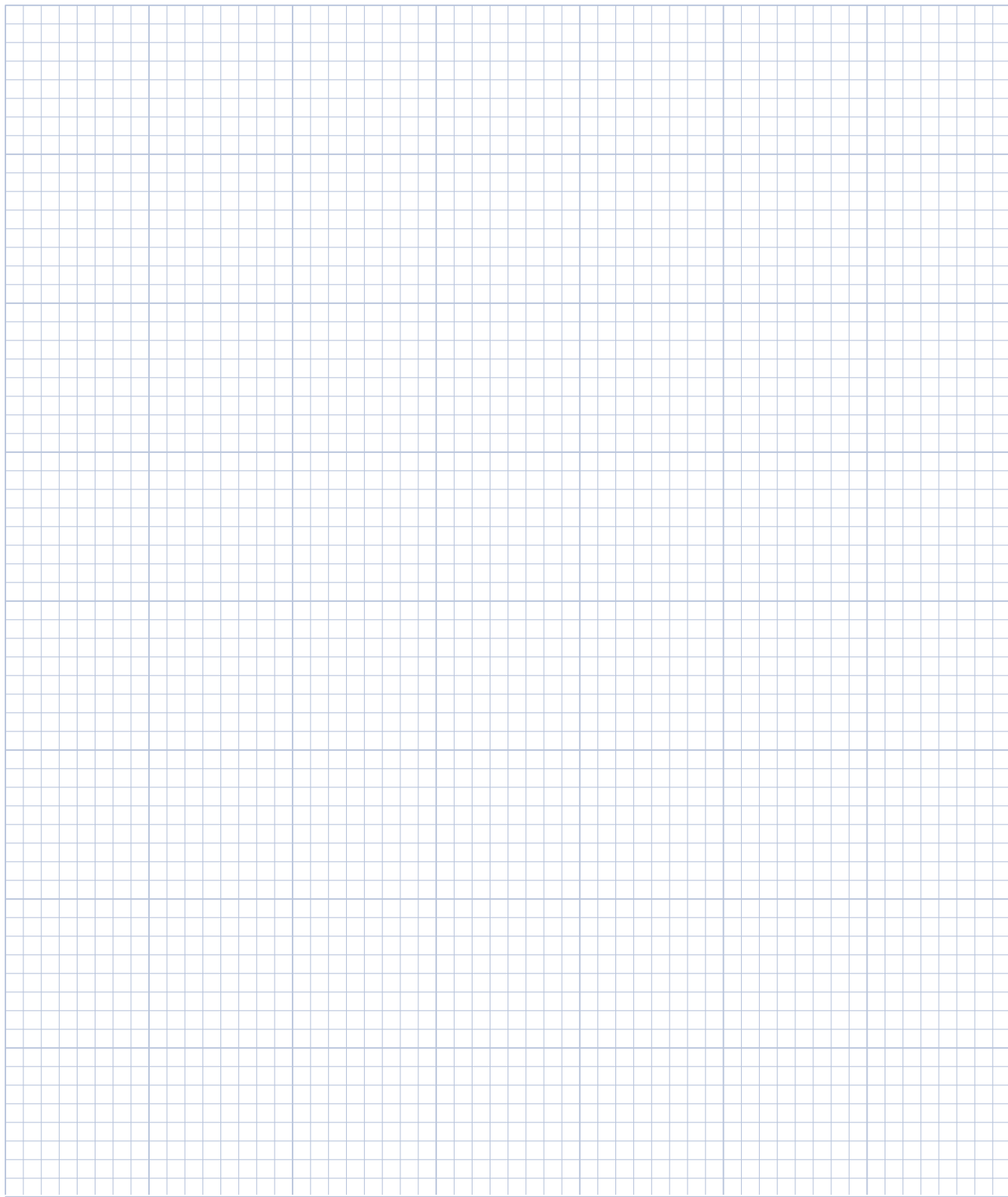

# Custom Applications

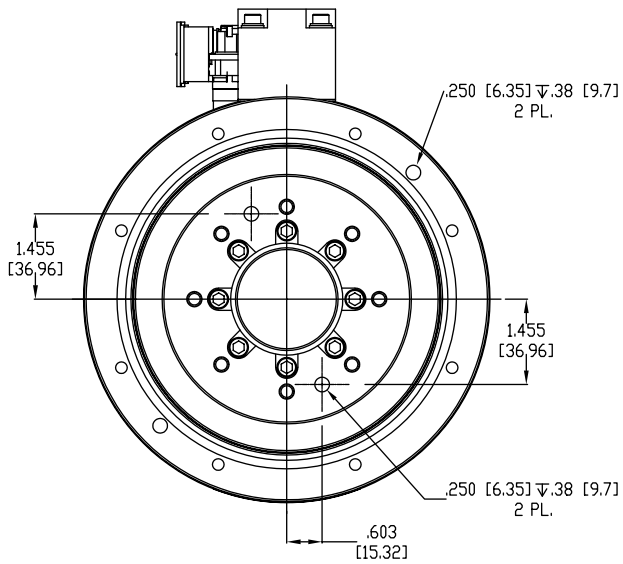

**PRECISION DOWEL PIN HOLES 0.250" FOR CUSTOMER INDEXING**

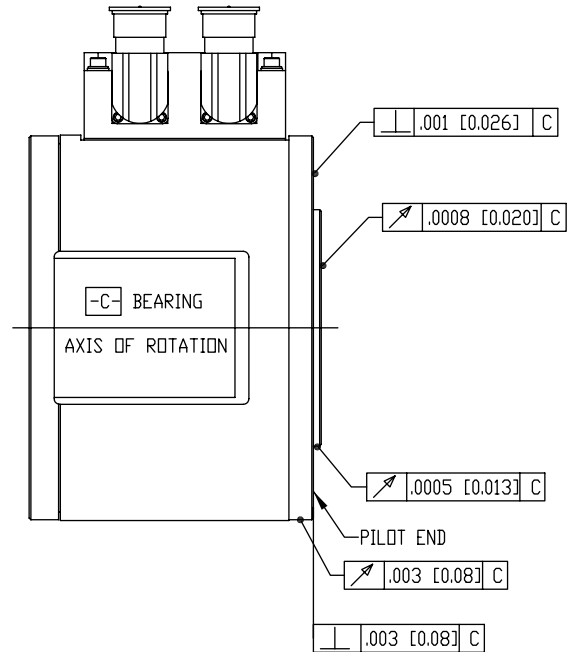

**DDR WITH PRECISION TOLERANCE COMPONENTS FOR PRECISE POSITIONING**

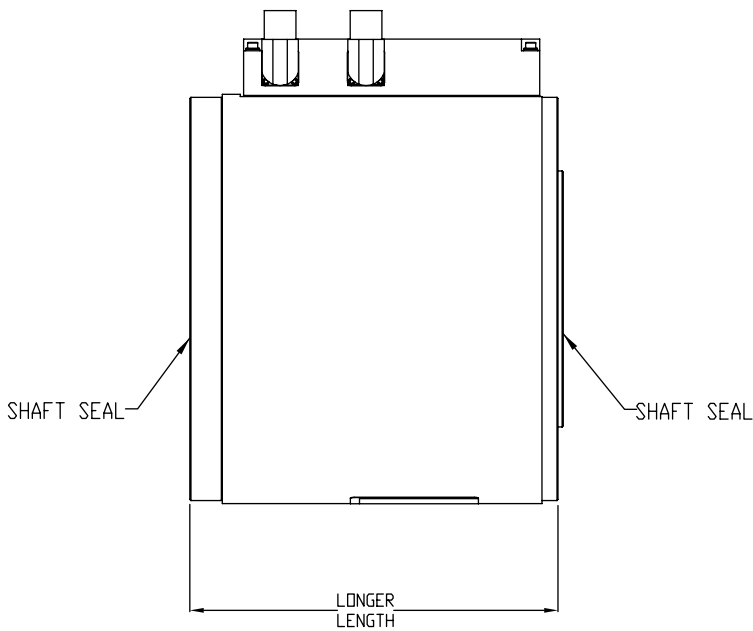

**DDR MOTOR, ENCODER OPTION WITH DUAL SHAFT SEALS, IP67**

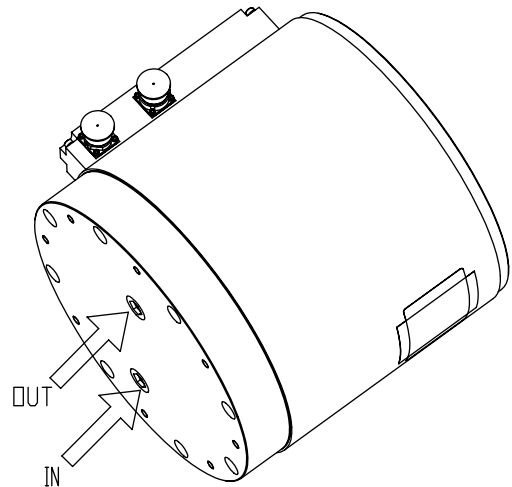

**DDR WITH AIR COOLING OPTION TO INCREASE CONTINUOUS OUTPUT TORQUE**



# Application Notes

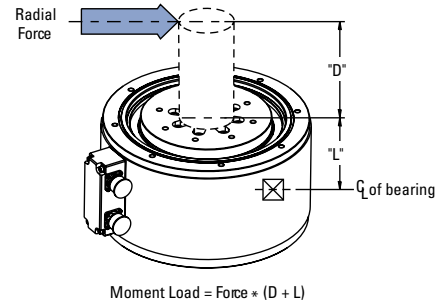
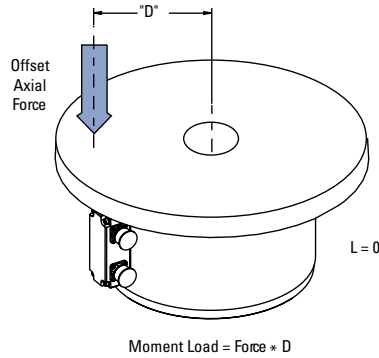
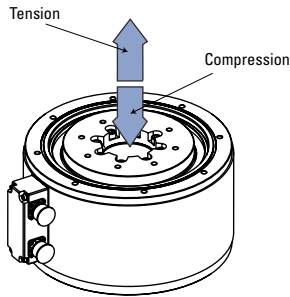

Model	Maximum Moment Load				Maximum Axial Load Ratings		
	Single Bearing		Dual Bearing		lbs	kg	
lb-ft	N-m	lb-ft	N-m	Compression			
D061	53.3	72.3	71.7	97.2	4500 932	2040 423	Compression Tension
D062	47.5	64.4	79.5	108			
D063	43.4	58.9	87.2	118			
D081	62.6	84.9	114	154	7400 819	3360 371	Compression Tension
D082	52.3	70.9	131	177			
D083	39.3	53.3	174	236			
D101	142	192	322	437	11700 1405	5300 637	Compression Tension
D102	108	146	279	378			
D103	72.6	98.4	305	413			
D141	234	317	472	640	11700 1405	5300 637	Compression Tension
D142	134	182	409	555			
D143	N/A	N/A	391	530			

### Application Notes:

1. Axial load rating dynamic values based on an  $L_{10}$  life rating when motor is mounted on a rigid base and running under normal operation conditions.  $L_{10}$  life ratings for applications where high rotational accuracy is desired or operation during vibration or shock, please contact customer support at (540) 633-3545, or through email at support@kollmorgen.com.
2. Standard motor is not designed for repetitive small angle oscillations less than  $\pm 13^\circ$ . Please contact customer support for additional options.
3. Motor is not intended to be directly coupled to a load which has its own two bearing system.
4. Motor may be mounted in any orientation provided the axial (both tension and compression) limits are observed. All applications having moment loads in tension should be reviewed by Customer Support.
5. All bolts for mounting load and base should be used to ensure stiff coupling.

Model	Dim. "L" (in)
D(H)06x	(1.05)
D(H)08x	(1.21)
D(H)10x	(1.58)
D(H)14x	(1.44)

# Model Nomenclature

## Housed DDR Motor

**DH 08 1 M - 1 2 - 1 3 1 0 - xxx**

**Direct Drive Series**

D = 115/230 VAC winding  
DH = 400/480 VAC winding

**Motor Frame Size**

06 = 6.93" O.D.  
08 = 8.60" O.D.  
10 = 11.19" O.D.  
14 = 14.25" O.D.

**Rotor Stack Length**

1 = Short stack  
2 = Mid stack  
3 = Long stack

**Winding Type**

A = Std. w/ resolver<sup>1</sup>  
M = Std. w/ sine encoder

**Mounting Option**

1 = Face mount  
2 = Flange mount

**Designated for Specials**

**Unit Seal**

0 = Non-sealed unit  
5 = IP65<sup>2</sup> - length increase  
7 = IP67<sup>2</sup> - length increase

**Bearing Option**

1 = Single bearing design  
2 = Dual bearing design<sup>3</sup>

**Feedback Device**

2 = Resolver ("A" Winding Type)<sup>1</sup>  
3 = Sine Encoder ("M" Winding Type)

**Shaft Option**

1 = Straight thru bore w/ face coupling

**Connector Type**

2 = Straight  
3 = 90°, rotatable

**Notes:**

1. Not available on D14x & DH14x.
2. Encoder sealed motors have increased length. See outline drawing.
3. Standard on D143 & DH143 models.

## AKD Servo Drive

**AKD - B 003 06 - NA AN- 0000**

**AKD Series**

**Version**

**B = Base drive**

P = Position indexer (motion tasking)

**Current Rating**

003 = 3 Amp  
006 = 6 Amp  
012 = 12 Amp  
024 = 24 Amp

**Voltage**

06 = 120/240 Vac 1Ø/3Ø  
07 = 480 Vac 3Ø

**Variants**

0000 = Standard

**Connectivity**

**AN = Analog command**

CN = CANopen  
EC = EtherCAT  
SQ = SynqNet

**Extension**

**NA = Without extensions**

Note: Options shown in bold blue text are considered standard.

# MOTIONEERING® Application Engine

To help select and size Kollmorgen components, this Windows®-based motor-sizing program takes a systems approach to the selection of brushless, DC servomotors, stepper motors and drives. MOTIONEERING application engine, available at [www.kollmorgen.com](http://www.kollmorgen.com), uses a project concept for the collection and saving of rotary and linear multi-axis load information. This provides the user the flexibility to sum the effects of multiple axes of motion for power supply and shunt regeneration sizing.

A wide variety of linear and rotary mechanisms are provided including lead screw, rack and pinion, conveyor, nip rolls, cylinder, rotary, and direct data-entry using unique sizing algorithms and product databases criteria.

The searchable database consists of hundreds of systems on product combinations including rotary housed and frameless brushless servomotors, direct drive rotary and linear brushless servomotors, linear positioners (electric cylinders, rodless positioners, and precision tables) and stepper systems.

The MOTIONEERING application engine also provides versatile units-of-measure selection options for mechanism and motion profile data-entry, with the ability to convert data into other available units. Online Help explains program functions and the definition of terms and equations used in the program.

## Features

- Group multiple mechanisms within a “project” – organize and combine data for power supply and regeneration sizing
- Types of mechanisms for analysis include lead screw, rack and pinion, conveyor, nip rolls, rotary and direct drive linear motor
- Motion profile options include simple triangle, 1/3-1/3-1/3 trapezoidal, variable traverse trapezoidal, and more
- Search results display shows color highlighted solution set of options for easy evaluation of system specifications and selection

## Supported Operating Systems

- Microsoft® Windows 2000, XP, Vista

## MOTIONEERING 6.0 includes

- Electric cylinder sizing and selection with AKM servomotor systems
- Rodless actuator with AKM servomotor systems (performance curves included)
- Precision table with AKM servomotor systems (performance curves included)
- PDF report functionality (includes application, drive, motor, positioner, and system specifications all in one easy-to-read report)

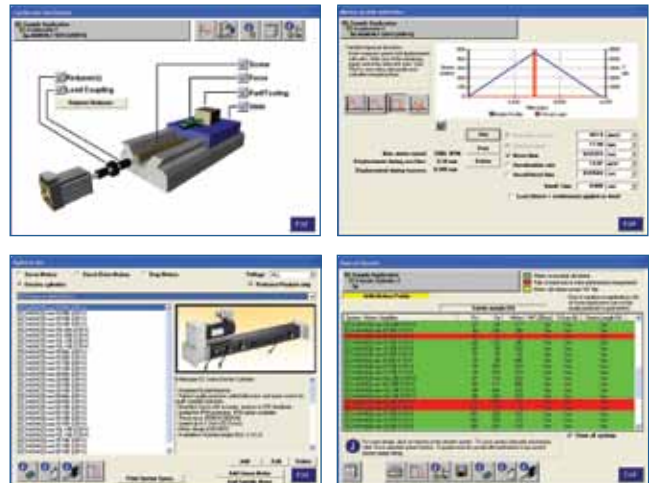

## About Kollmorgen

Kollmorgen is a leading provider of motion systems and components for machine builders. Through world-class knowledge in motion, industry-leading quality and deep expertise in linking and integrating standard and custom products, Kollmorgen delivers breakthrough solutions that are unmatched in performance, reliability and ease-of-use, giving machine builders an irrefutable marketplace advantage.

**For assistance with your application needs in North America, contact us at: 540-633-3545, [support@kollmorgen.com](mailto:support@kollmorgen.com) or visit [www.kollmorgen.com](http://www.kollmorgen.com) for a global contact list.**

- Application Centers
- Global Design & Manufacturing
- Global Manufacturing

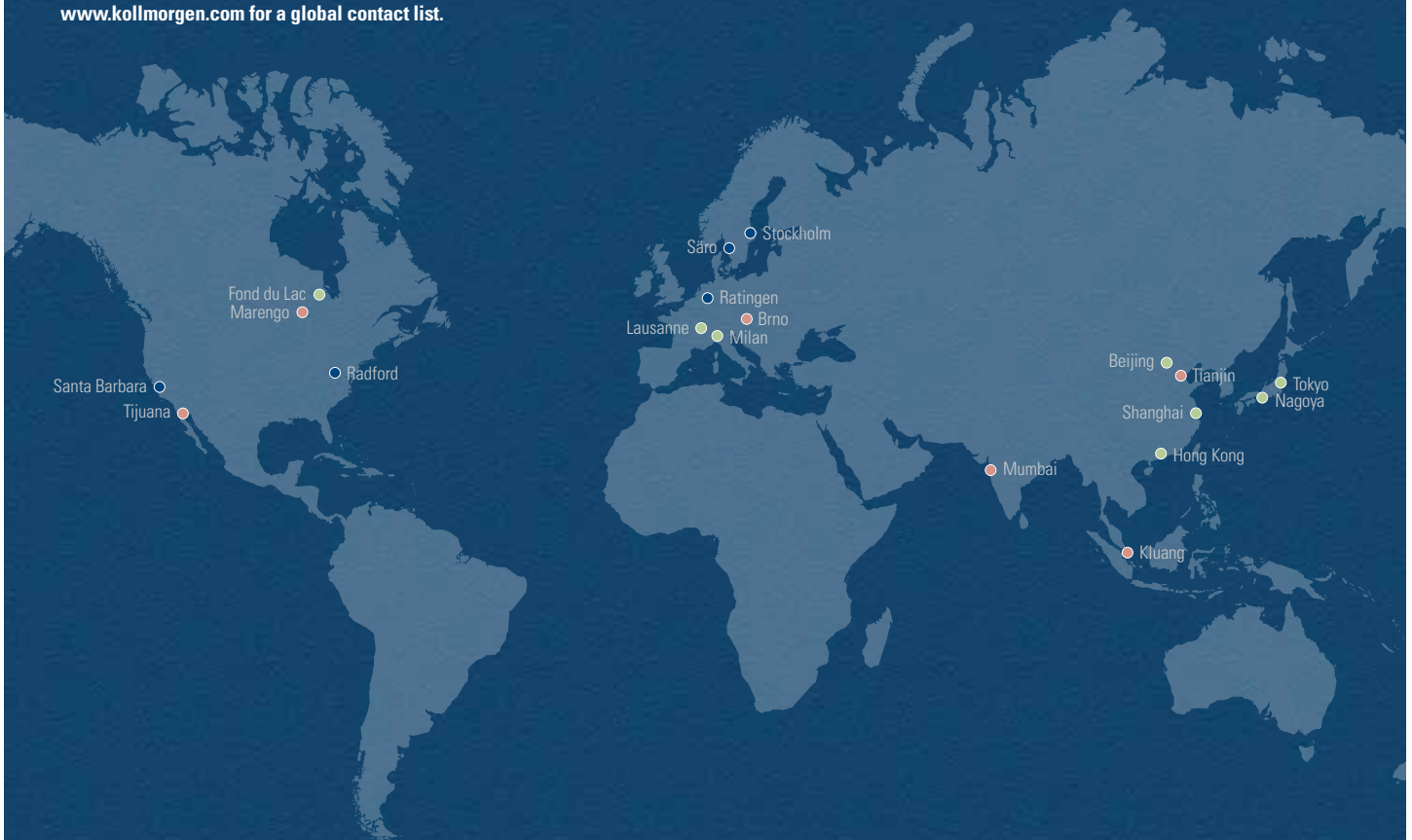

**KOLLMORGEN**®

*Because Motion Matters™*

Kollmorgen  
203A West Rock Road  
Radford, VA 24141 USA  
Phone: 1-540-633-3545  
Fax: 1-540-639-4162