

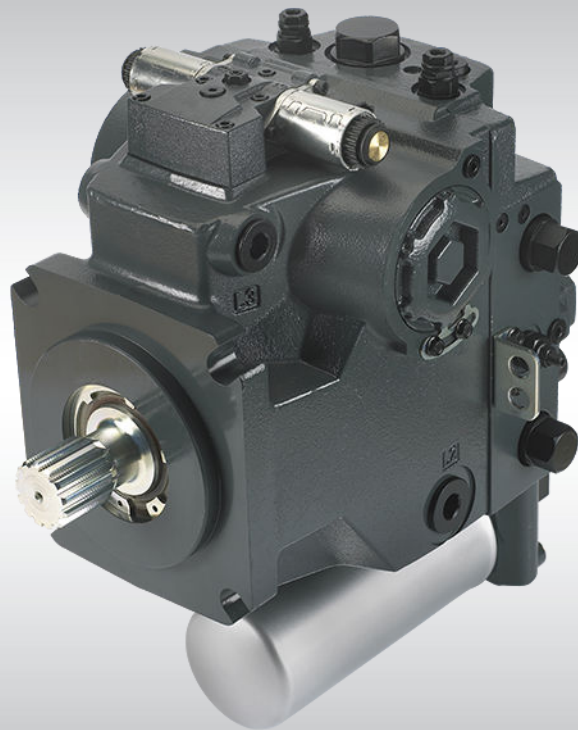

Technical Information

H1 Axial Piston Pump 115/130 147/165

ISL Integrated Speed Limitation



Revision History*Table of Revisions*

Date	Changed	Rev
Mar 2014	Converted to Danfoss layout - DITA CMS	BA
Aug 2009	First edition	AA

Contents**Danfoss hydrostatic product family**

General description.....	4
General description H1 Family of hydrostatic pumps.....	4

H1 general information

The H1 range of products.....	6
A growing family.....	6
A word about the organization of this manual.....	6
System schematic.....	6

Operation

Operation.....	7
The performance of ISL and advantages for the system are:.....	7
When is ISL- function required:.....	7
Function of the Integrated Speed Limitation.....	7
Advantages:.....	8

Frame 115/130 cm³ Single Pump

Technical specifications.....	9
Model code.....	10
Installation drawings.....	14
Port description.....	14
Dimensions.....	16
Controls.....	18
Displacement limiters.....	19
Filtration.....	20

Frame 147/165 cm³ Single Pump

Technical specifications.....	21
Model code.....	22
Installation Drawings.....	25
Port description.....	25
Dimensions.....	27
Controls.....	29
Filtration.....	31

Danfoss hydrostatic product family
General description

The H1 axial piston variable displacement pumps are of cradle swashplate design and are intended for closed circuit applications.

The flow rate is proportional to the pump input speed and displacement.

The latter is infinitely adjustable between zero and maximum displacement.

Flow direction is reversed by tilting the swashplate to the opposite side of the neutral (zero displacement) position.

- 4 different displacements with ISL: 115.8 cm³ [7.07 in³], 130.8 cm³ [7.98 in³], 147 cm³ [8.97 in³], and 165 cm³ [10.07 in³]
- Electric displacement control (EDC)
- Forward-Neutral-Reverse (FNR)
- Non Feedback Proportional Electric (NFPE)
- Improved reliability and performance
- More compact and lightweight

General description H1 Family of hydrostatic pumps

The H1 family of closed circuit variable displacement axial piston pumps is designed for use with all existing Danfoss hydraulic motors for the control and transfer of hydraulic power. H1 pumps are compact and high power density where all units utilize an integral electro-hydraulic servo piston assembly that controls the rate (speed) and direction of the hydraulic flow. H1 pumps are specifically compatible with the Danfoss family of PLUS+1 microcontrollers for easy Plug-and-Perform installation.

H1 pumps can be used together in combination with other Danfoss pumps and motors in the overall hydraulic system. Danfoss hydrostatic products are designed with many different displacement, pressure and load-life capabilities. A quick overview of the total Danfoss hydrostatic pump and motor product line is shown below. Go to the Danfoss website or applicable product catalog to choose the components that are right for your complete closed circuit hydraulic system.

Hydrostatic products family overview

Product name	Product description	Displacement range	Pressure rated	Control options available	Technical information no.
Series 70	Pumps, Integral transmission	10-21 cc/rev	145 bar	Pumps: DDC	BLN-10006
Series 15	Pumps, Integral tandem pumps, Fixed motors, Integral transmissions	15 cc/rev	310 bar	Pumps: DDC Motors: Fixed	BLN-10006
Series 40	Pumps, Integral tandem pumps, Fixed & Variable motors	25-46 cc/rev	350 bar	Pumps: DDC, MDC, EDC, FNR Motors: Fixed	520L0635 520L0636
Series 42	Pumps	28-51 cc/rev	400 bar *	MDC, NFPH	BLN-10092
L/K	Variable motor	25-45 cc/rev	400 bar *	Hydraulic pilot	520L0627
Series 90	Pumps Fixed motors	42-250 cc/rev 42-100 cc/rev	450 bar	MDC, EDC, FNR, NFPE Fixed	520L0603 520L0604
H1	Pumps	45-165 cc/rev	450 bar *	EDC	520L0823
Series 51	Variable motors	60-250 cc/rev	450 bar	2-Position & Proportional (hydraulic & electric)	520L0440
LSHT	LSHT motors exist in many sizes and pressure ranges.				
* Varies by displacement					

DDC: Direct Displacement Control (non servo)

MDC: Manual Displacement Control (integral servo)

Danfoss hydrostatic product family

EDC: Electric Displacement Control (integral servo)
FNR: Forward – Neutral – Reverse (electric 3 position)
NFPE: Non Feedback Proportional Electric (integral servo)
NFPH: Non Feedback Proportional Hydraulic
LSHT: Low Speed High Torque motors
NA: Not Applicable.

H1 general information

The H1 range of products

A growing family

- Initial release of four displacements
- Development plans include additional displacements

A word about the organization of this manual

General information covering all displacements of the H1 range is given in the beginning of this manual. This includes definitions of operating parameters and system design considerations. Sections later in this book detail the specific operating limitations for each frame and give a full breakdown of available displacements, features and options, and basic installation drawings.

The table below shows the available range of H1 pumps as of this printing, with their respective speed, pressure, theoretical flow ratings, and mounting flange. The starting page number of the specific section is shown for each frame.

Pump	Displacement		Speed			Pressure				Theoretical flow (at rated speed)		Mounting flange
			Min.	Rated	Max.	Application pressure*		Maximum working pressure				
	cm ³	[in ³]		min-1 (rpm)		bar	[psi]	bar	[psi]	l/min	[US gal/min]	SAE
Frame 115/130 Single pumps												see page 10
H1P115	115.8	[7.07]	500	3200	3400	450	[6525]	480	[6960]	371	[98]	D
H1P130	130.8	[7.98]								419	[111]	
Frame 147/165 Single pumps												see page 26
H1P147	147.0	[8.97]	500	3000	3100	450	[6525]	480	[6960]	441	[117]	D
H1P165	165.0	[10.07]								495	[131]	

* Operation above application pressure is permissible with Danfoss application approval

System schematic

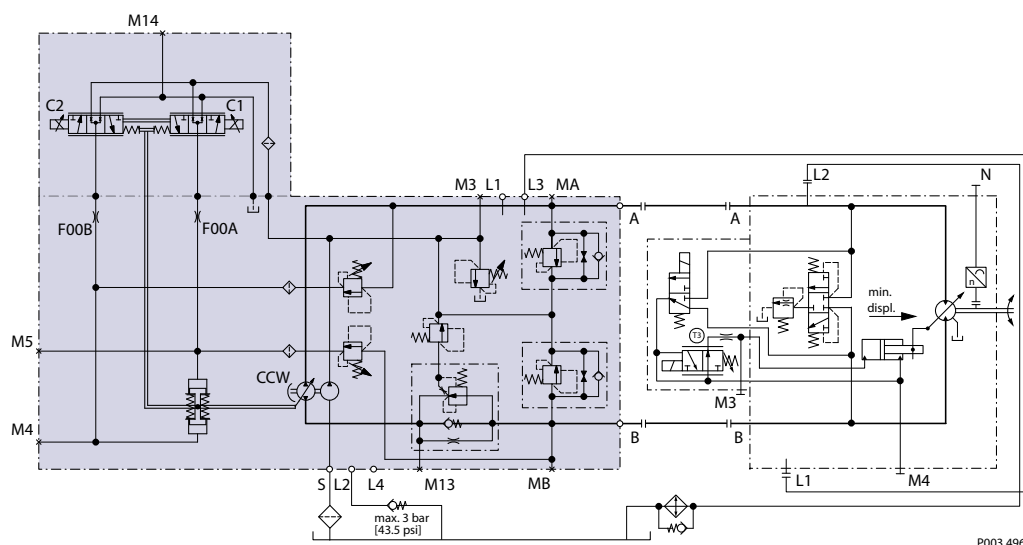

P003 496E

Above schematics show the function of a hydrostatic transmission using a H1 axial piston variable displacement pump with electric displacement control (EDC) and a bent axis variable displacement motor with two-position control.

Operation

Operation

More and more problems arise by overspeeding of the diesel engine in self-propelled machines which are equipped with hydrostatic propel drive systems. This overspeeding of the diesel engine appears when the machine works in downhill- or in braking mode. As a result, the diesel engine as well as the attached components exceed the maximum speed so that defects could occur. For this, the reasons are both the limited braking torque of the today used turbo charged diesel engines and the high machine's weight.

To avoid this we have developed a system which prevents overspeeding by means of integrated valves in the pump. This feature is called Integrated Speed Limiting (ISL) and is offered for H1 pumps.

The performance of ISL and advantages for the system are:

- Sufficient deceleration of the vehicle when braking
- Protect the diesel engine and the hydraulic pump against over-speed
- Ensures an optimal use of the diesel engines brake capability
- Provides high comfort of driving because it acts independent from the operator
- It saves the mechanical brakes
- No additional hydrostatic components or others (like retarders) are required for this function

When is ISL- function required:

- Turbocharged diesel engine with low braking power is used
- Braking power of the diesel engine is not adequate for the machine mass and speed (mass up to 29 t; speed up to 30 km/h [18.64 mile/hour])
- High pressure in the pump has to be limited when braking, brake pressure acting on the hydraulic motor should be high
- Mechanical brakes will have less load.

Function of the Integrated Speed Limitation

Example of the dynamic braking: the machine is driving on flat ground with high speed and should be stopped hydrostatically. This is usually done by pulling back the control handle. As a result, the displacement of the pump will be decreased by the servo control and consequently, the machine will slow down. Here, the hydraulic motor works like a pump which is driven by the machine's mass. Due to this fact, the high pressure sides - in the closed hydraulic loop - change although the flow direction is constant: now the machine is in braking mode.

Now the hydraulic pump has a pressure increase at the low pressure side so that the pump tries to increase the speed and/or to built up a torque respectively. This torque is transferred to the diesel engine by the pump shaft which would normally lead to an overspeeding situation.

The special feature of the system is a *pilot operated pressure reducing valve* and an *orifice* which are installed in the pump's endcap. The components are located between motor and pump to reduce the maximum pressure of the pump while braking.

The pressure reducing valve closes at a certain pressure controlled by the pilot valve (e.g. 200 bar [2900 psi]) which is equivalent to the diesel motor's braking capability. At the same time, the system signals the control the effective braking pressure of 450 bar [6500 psi] to stroke the pump to maximum displacement to ensure taking off the oil which is delivered by the motor.

Additionally, there is an orifice which is installed in parallel to the pressure reducing valve to continue controlling the pump at the maximum pressure while the machine is slowing down - although the amount of oil decreases. Now, the diesel engine can take up the maximum braking capability which it is able to manage. By this, a high temperature increase in the hydraulic circuit will be avoided.

Operation

In reverse driving direction the *bypass valve* opens and allows normal driving.

Advantages:

- Avoiding overspeeding of the diesel motor and their flanged components
- The hydrostatic braking power of the machine is not to be influenced – the motor always records the maximum braking pressure of 450 bar [6500 psi]
- No influences regarding driving comfort
- Easy to retrofit
- Nearly the same installation dimensions as standard pumps
- No electronic / sensors are necessary

Hydraulic diagram of H1 with Integrated Speed Limitation

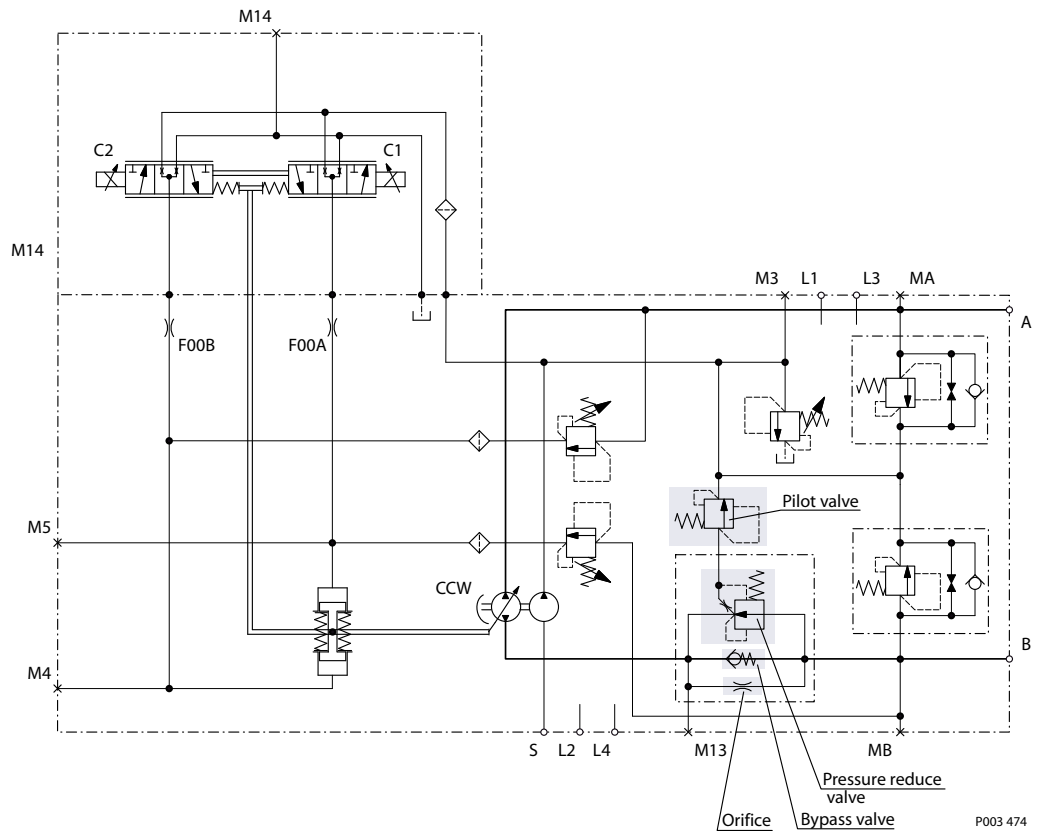

P003 474

Technical Information H1 Axial Piston Pump 115/130 147/165 ISL Integrated Speed Limitation

Frame 115/130 cm³ Single Pump

Technical specifications

For definitions of the following specifications, see Operating parameters.

General specifications

Design	Axial piston pump of cradle swashplate design with variable displacement
Direction of rotation	Clockwise, counterclockwise
Pipe connections	Main pressure ports: ISO Split Flange Boss
	Remaining ports: SAE straight thread O-ring boss
Recommended installation position	Pump installation position is discretionary, however the recommended control position is on the top or at the side. If the pump is installed with the control at the bottom, it is recommended to flush the case through port M14 located at the EDC and NFPE control. Vertical input shaft installation is acceptable. Consult Danfoss for non conformance to these guidelines. The housing must always be filled with hydraulic fluid.
Auxiliary cavity pressure	Will see inlet pressure with internal charge pump. Will be case pressure with external charge supply. Please verify mating pump shaft seal capability.

Physical properties

Feature	Unit	Frame size	
		115	130
Displacement	cm ³ [in ³]	115.8 [7.07]	130.8 [7.98]
Flow at rated (continuous) speed	l/min [US gal/min]	371 [98]	419 [111]
Torque at maximum displacement (theoretical)	N·m/bar [lbf·in/1000psi]	1.83 [1120]	2.07 [1260]
Mass moment of inertia of rotating Components	kg·m ² [slug·ft ²]	0.021 [0.0155]	
Weight dry (without PTO and filter)	kg [lb]	83 [187]	
Oil volume	liter [US gal]	3 [0.8]	
Mounting flange		SAE flange, size D (SAE J 744) mounting pad	
Auxiliary mounting		SAE A, SAE B, SAE B-B, SAE C, SAE D	
Shafts		Splined: 27-teeth 16/32, 13-teeth 8/16	
Suction ports		1.625-12UN-2B [1 5/8 -12UN-2B]	
Main port configuration		∅31.5 - 450 bar split flange boss per ISO 6162, M12x1.75	
Case drain ports L2, L4 (SAE O-ring boss) preferred usage		1.3125-12UNF-2B [1 5/16 -12UNF-2B]	
Other ports		SAE O-ring boss. See Installation drawings.	
Customer interface threads		Metric fastener	

Operating parameters

Feature	Unit	Frame size	
		115	130
Input speed	Minimum for internal charge supply	min ⁻¹ (rpm)	500
	Minimum for external charge supply		500
	Minimum for full performance		1200
	Rated		3200
	Maximum		3400
System pressure	Application pressure	bar [psi]	450 [6525]

Technical Information H1 Axial Piston Pump 115/130 147/165 ISL Integrated Speed Limitation

Frame 115/130 cm³ Single Pump

A Rotation

L	Left hand (counter clockwise)
R	Right hand (clockwise)

B Product version

B	Revision code
---	---------------

D Control

A2	Electric Displacement Control (EDC) 12V, Deutsch connector
A3	Electric Displacement Control (EDC) 24V, Deutsch connector
A4	Electric Displacement Control (EDC) 12V, Deutsch connector, manual override
A5	Electric Displacement Control (EDC) 24V, Deutsch connector, manual override
A8	Non Feedback Proportional Electric (NFPE) 12V, Deutsch connector, manual override (align with option E: Displacement limiters & option W: Special hardware)
B8	Non Feedback Proportional Electric (NFPE) 24V, Deutsch connector, manual override (align with option E: Displacement limiters & option W: Special hardware)

F Orifices

C1	Orifices, 0.8 mm in servo supply 1 and 2, recommended for propel applications
C2	Orifices, 1.3 mm in servo supply 1 and 2 (standard), recommended for propel applications

E Displacement limiters

N	None
C	No limiters, with nested springs (required for NFPE)
B	Adjustable externally (see option Y: Settings for adjustment, if applicable)
D	Adjustable externally with nested springs, required for NFPE (see option Y: Settings for adjustment, if applicable)

G Endcap options

	Twin port, 4-bolt split flange (code 62)	
Match with below options (K)	Auxiliary mounting pad none, SAE-A, B, B-B, C	
Match with below options (T)	Suction filtration	Integral full charge flow filtration
D4		X
E8	X	

H Mounting

G	SAE D 4-bolt
---	--------------

J Input shaft

G3	13 teeth splined shaft 8/16 pitch
G2	27 teeth splined shaft 16/32 pitch

Technical Information H1 Axial Piston Pump 115/130 147/165 ISL Integrated Speed Limitation
Frame 115/130 cm³ Single Pump
K Auxiliary mounting pad (align with endcap selection, option G)

NN	None
H2	SAE A pad, 9 teeth 16/32 coupling, shipping cover
H1	SAE A pad, 11 teeth 16/32 coupling, shipping cover
H3	SAE B pad, 13 teeth 16/32 coupling, shipping cover
H5	SAE B-B pad, 15 teeth 16/32 coupling, shipping cover
H6	SAE C pad, 14 teeth 12/24 coupling, shipping cover

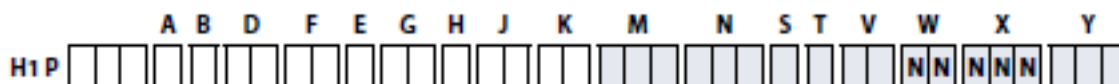

M Overpressure protection type and setting side "A" **

N Overpressure protection type and setting side "B" **

** Pressure Protection Type must be the same for side "A" and "B"

L	High pressure relief valve + pressure limiters with bypass
L15	150 bar [2180 psi]
L20	200 bar [2900 psi]
L23	230 bar [3336 psi]
L25	250 bar [3630 psi]
L28	280 bar [4061 psi]
L30	300 bar [4350 psi]
L33	330 bar [4786 psi]
L35	350 bar [5080 psi]
L38	380 bar [5510 psi]
L40	400 bar [5800 psi]
L42	420 bar [6090 psi]
L43	430 bar [6237 psi]
L44	440 bar [6382 psi]
L45	450 bar [6960 psi]

S Charge pump

A	26 cm ³ /rev [1.59 in ³ /rev]
L	34 cm ³ /rev [2.07 in ³ /rev]

T Filtration options (align with endcap selection, option G)

L	Suction filtration (see basic drawings)
M	Integral full charge flow filtration with bypass sensor and bypass

V Charge pressure relief setting

20	20 bar [290 psi]
24	24 bar [348 psi]

Technical Information H1 Axial Piston Pump 115/130 147/165 ISL Integrated Speed Limitation

Frame 115/130 cm³ Single Pump
V Charge pressure relief setting (continued)

30	30 bar [435 psi]
----	------------------

W Special hardware features

NN	None
M1	NFPE valve plate (align with option D: Control selection and option E: Displacement limiters)

X Paint and nametag

NNN	Black paint and Danfoss nametag
-----	---------------------------------

Y Special settings

G14	ISL Pressure setting 140 bar [2031 psi]
G18	ISL Pressure setting 180 bar [2610 psi]
G21	ISL Pressure setting 210 bar [3046 psi]
G23	ISL Pressure setting 230 bar [3335 psi]
G25	ISL Pressure setting 250 bar [3630 psi]

Frame 115/130 cm³ Single Pump

Installation drawings

Port description

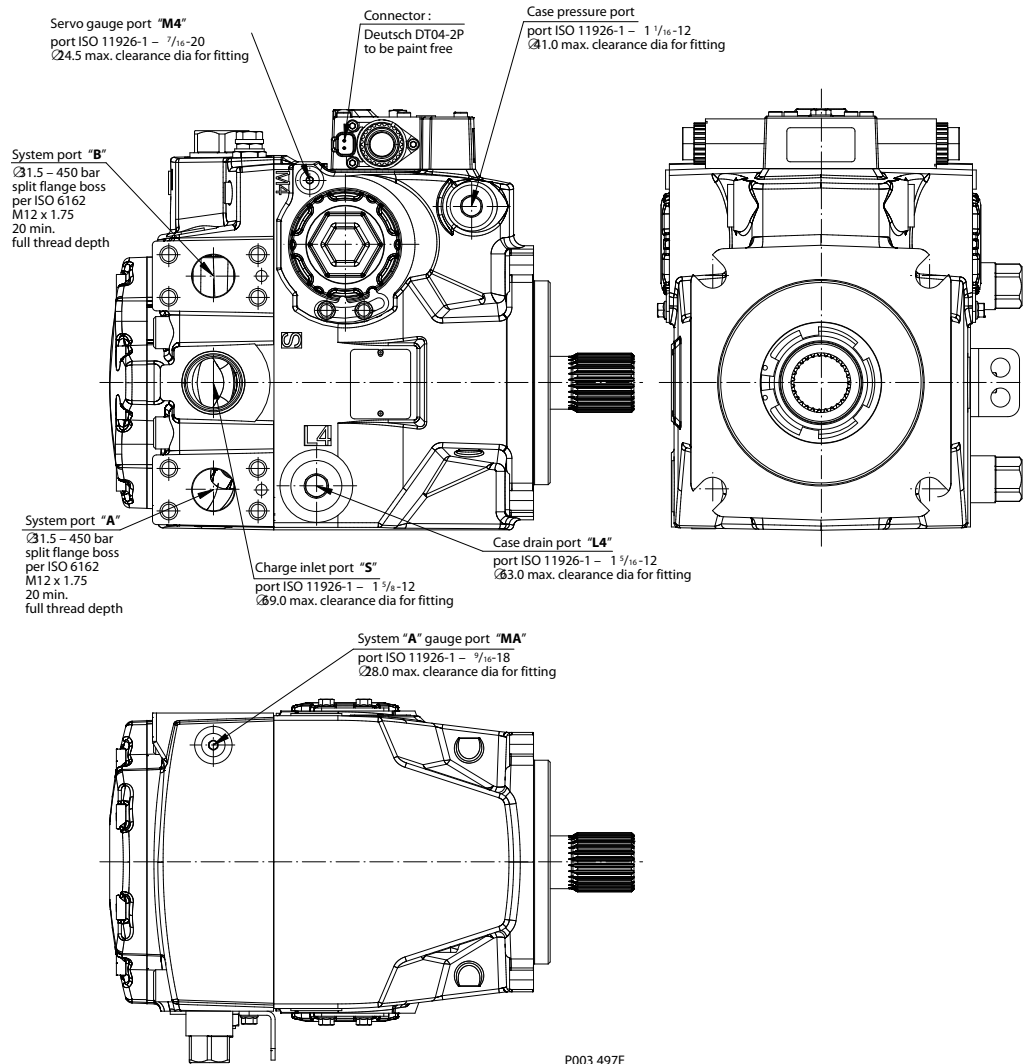

Port description

Port	Description	Sizes
A	System port "A"	∅ 31.5
B	System port "B"	∅ 31.5
E	Charge filtration port, from filter	1 1/16 -12
F	Charge filtration port, to filter	1 1/16 -12
L2	Case drain port	1 5/16 -12
L4	Case drain port	1 5/16 -12
MA	System "A" gage port	9/16 -18
MB	System "B" gage port	9/16 -18

Technical Information H1 Axial Piston Pump 115/130 147/165 ISL Integrated Speed Limitation

Frame 115/130 cm³ Single Pump

Port description (continued)

M3	Charge gage port, after filtering	9/16 -18
M4	Servo gage port	7/16 -20
M5	Servo gage port	7/16 -20
M14	Case gage port	7/16 -20
S	Charge inlet port	1 5/8 -12
M13	Gage port, high pressure at kit	9/16 -18

Please contact Danfoss for specific installation drawings.

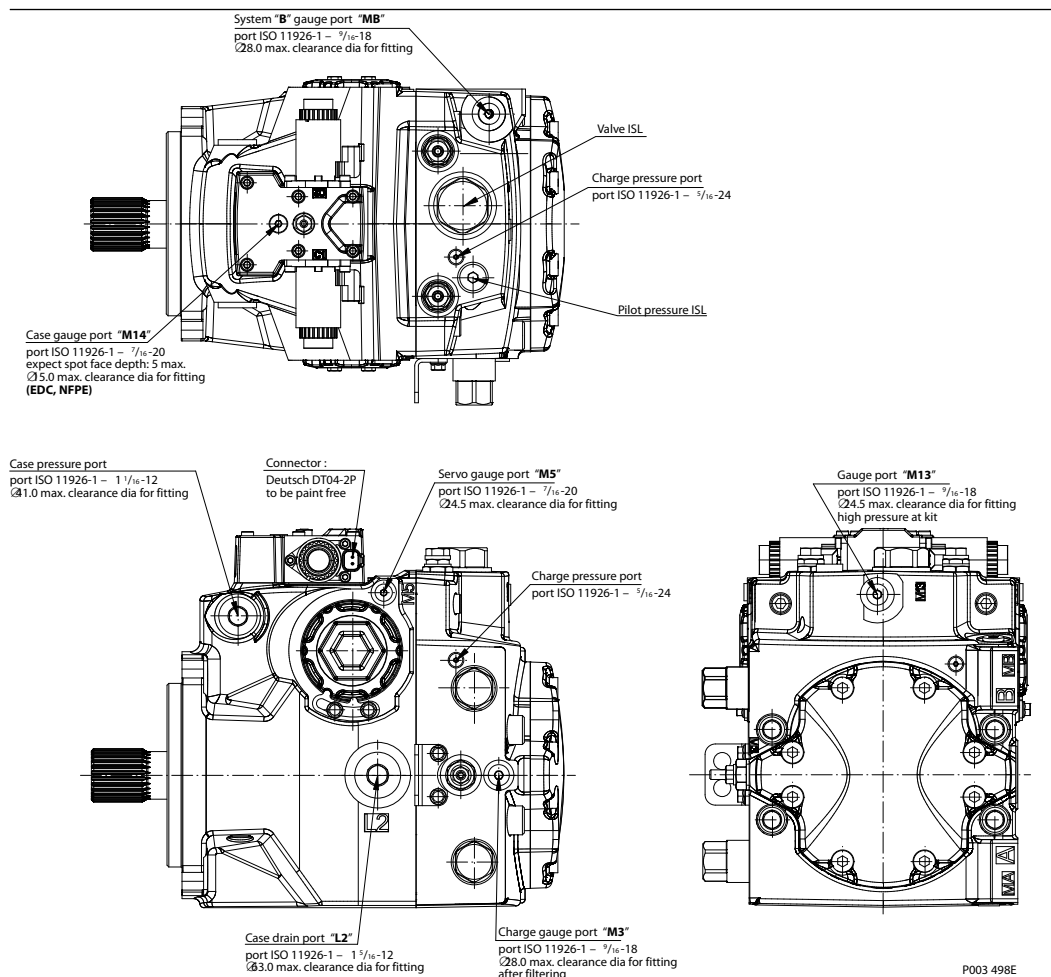

Please contact Danfoss for specific installation drawings.

Frame 115/130 cm³ Single Pump

Dimensions

Servo gauge port "M4"
port ISO 11926-1 - 7/16-20
Ø24.5 max. clearance dia for fitting

System port "B"
Ø1.5 - 450 bar
split flange boss
per ISO 6162
M12 x 1.75
20 min.
full thread depth

Charge inlet port "S"
port ISO 11926-1 - 1 1/8-12
Ø9.0 max. clearance dia for fitting

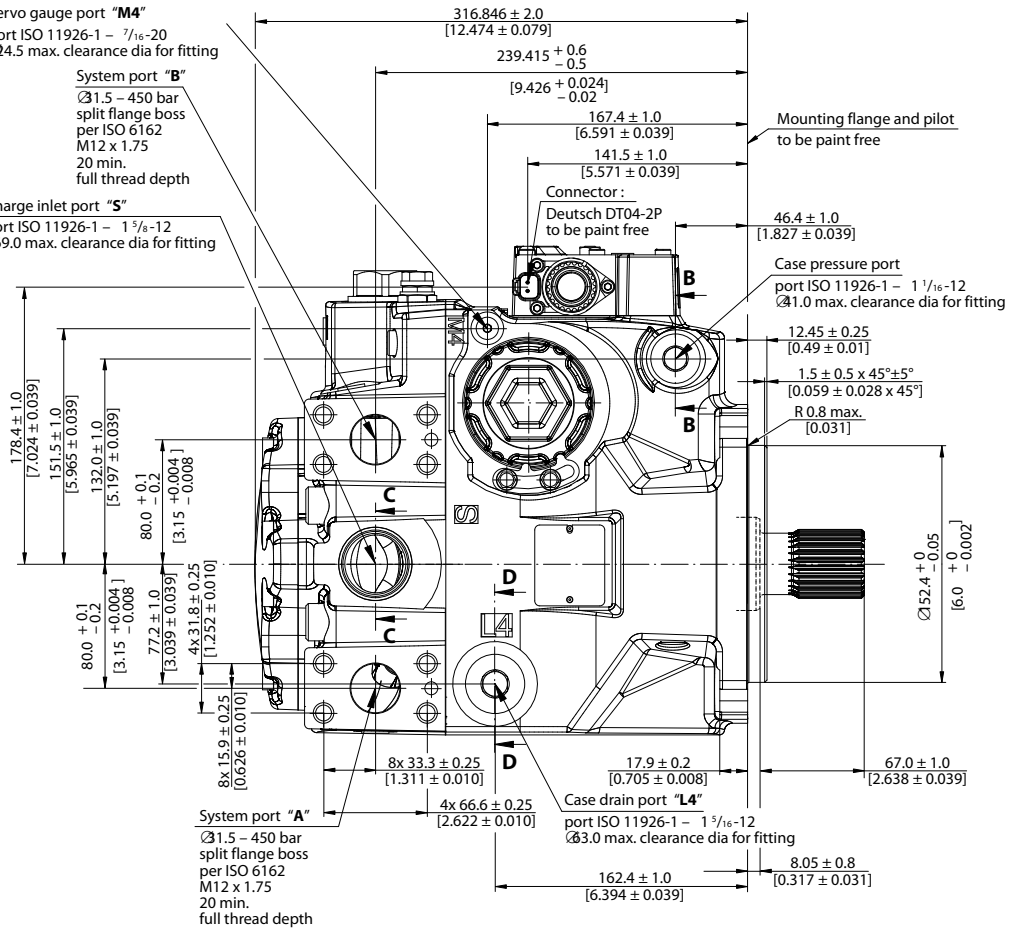

B-B (2x)

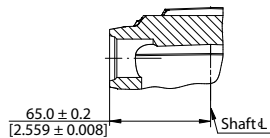

C-C

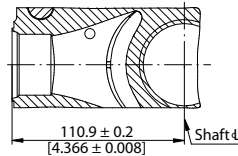

D-D

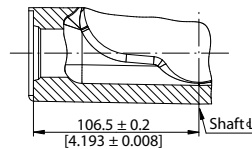

P003 499E

Please contact Danfoss for specific installation drawings.

Frame 115/130 cm³ Single Pump

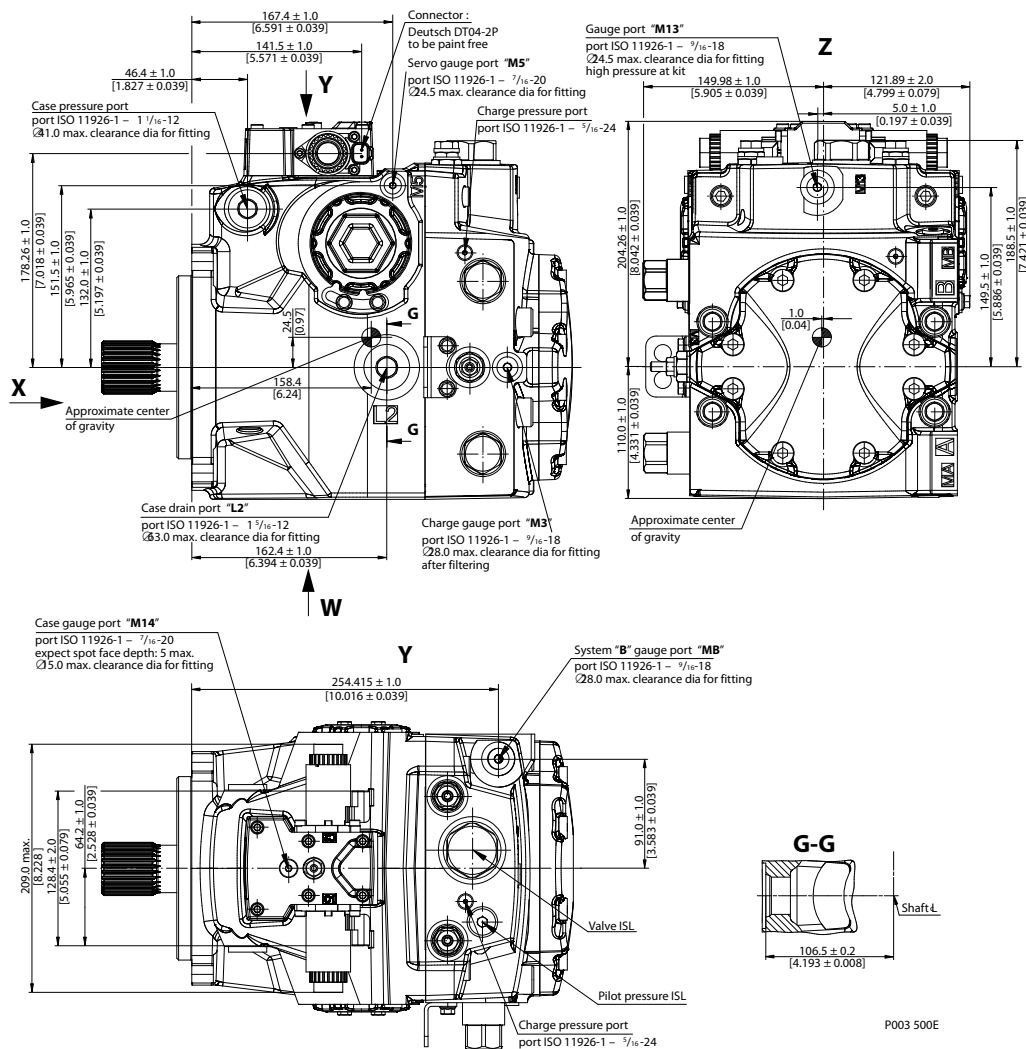

Please contact Danfoss for specific installation drawings.

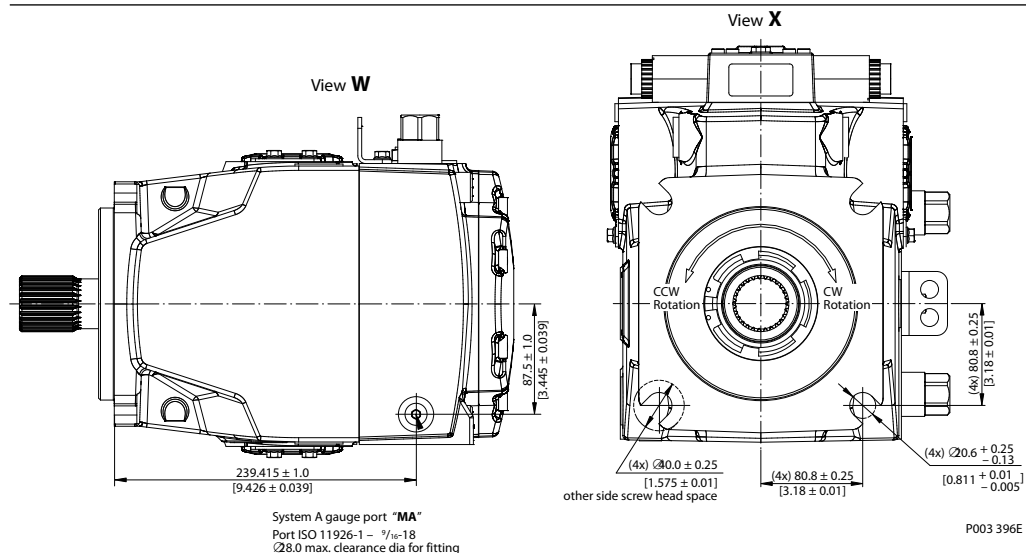

Frame 115/130 cm³ Single Pump

Please contact Danfoss for specific installation drawings.

Controls

Electric Displacement Control (EDC), option A2 (12 V)/A3 (24 V)

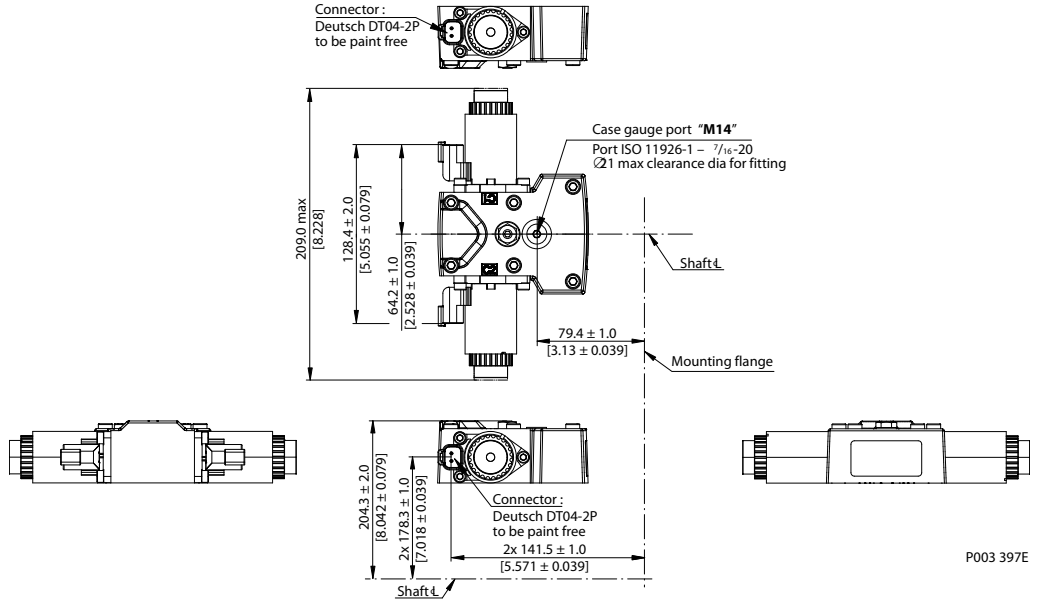

Electric Displacement Control (EDC) with manual override, option A4 (12 V)/A5 (24 V)

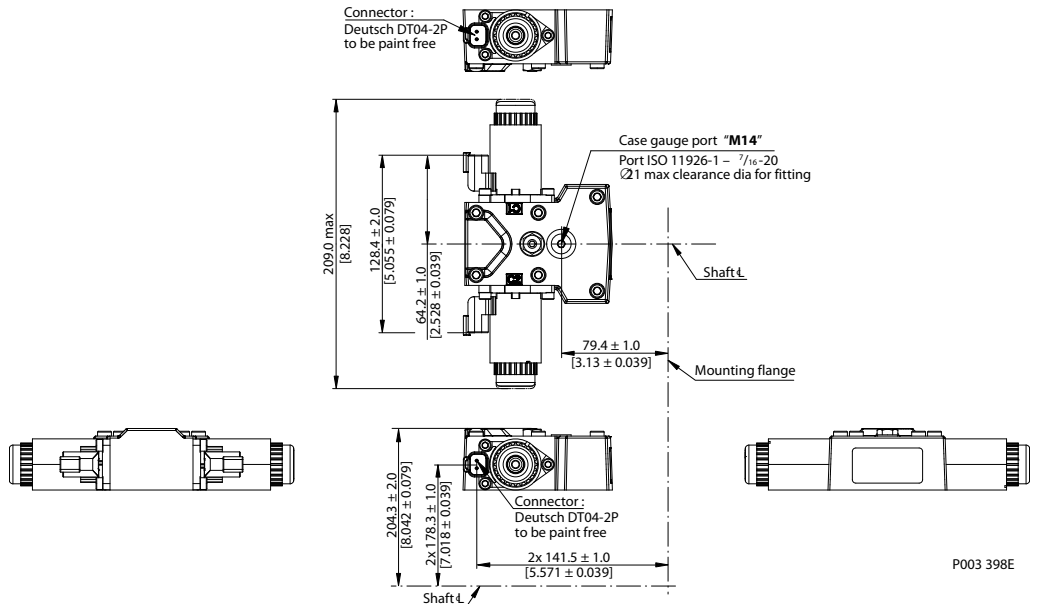

Please contact Danfoss for specific installation drawings.

Frame 115/130 cm³ Single Pump

Non Feedback Proportional Electric Displacement control (NFPE) with manual override, option A8 (12 V)/B8 (24 V)

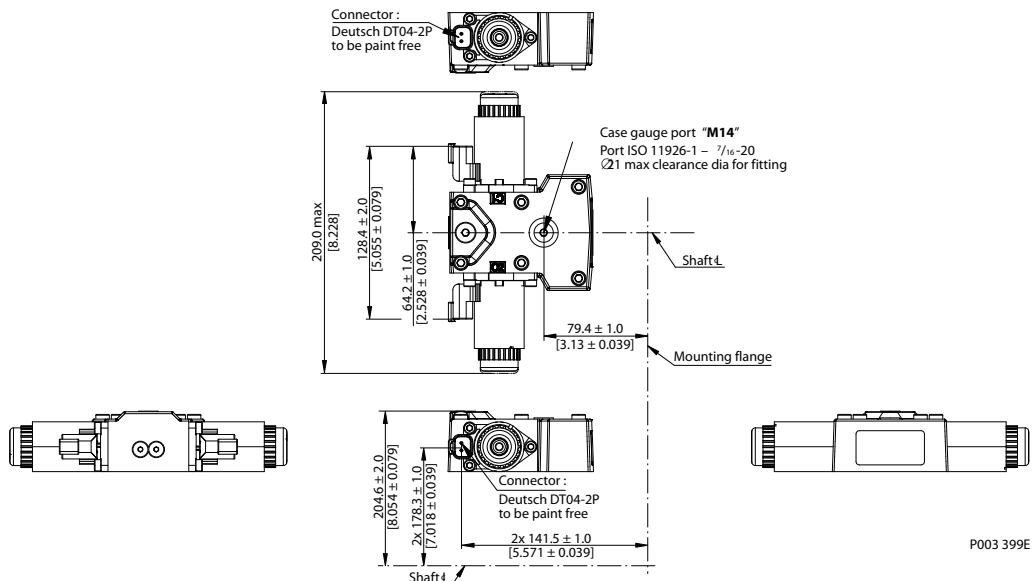

Please contact Danfoss for specific installation drawings.

Displacement limiters

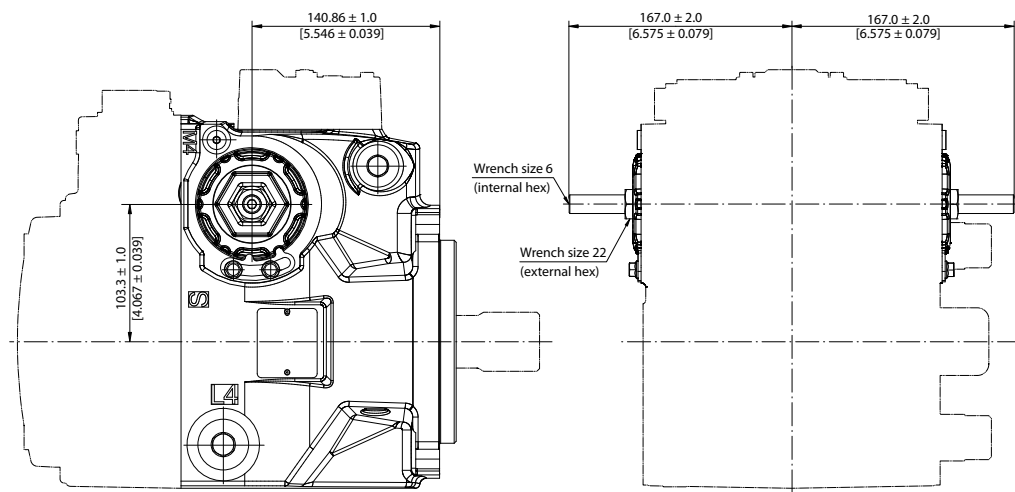

P003 501E

Please contact Danfoss for specific installation drawings.

Frame 115/130 cm³ Single Pump

Filtration

Suction filtration, option L

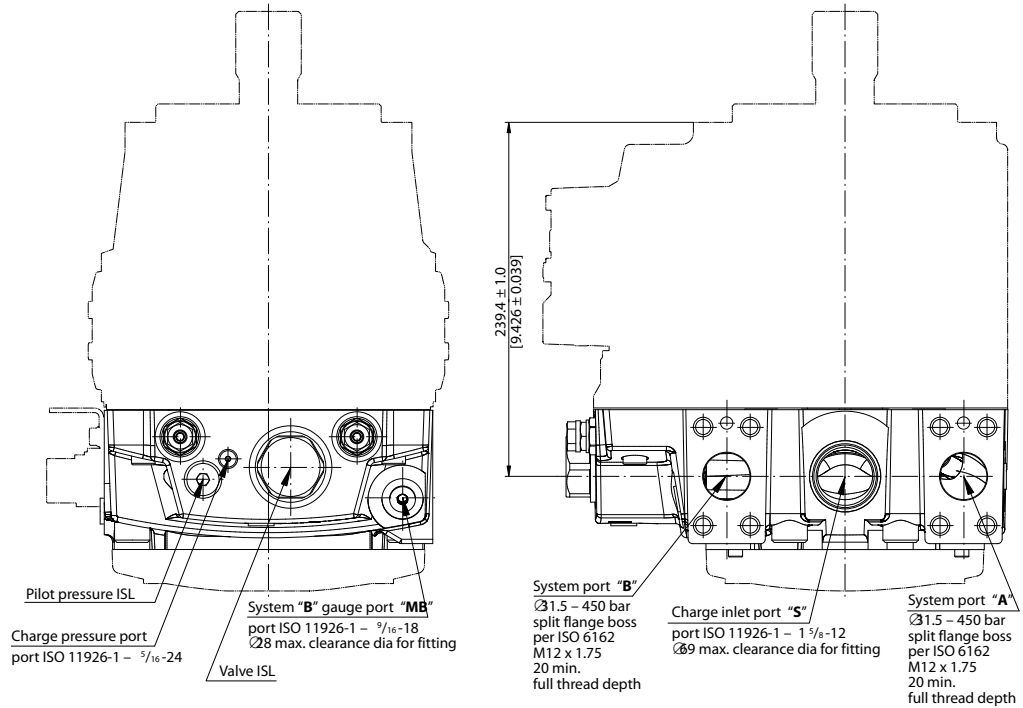

P003 502E

Please contact Danfoss for specific installation drawings.

Integral full flow charge pressure filtration with filter bypass sensor, option M

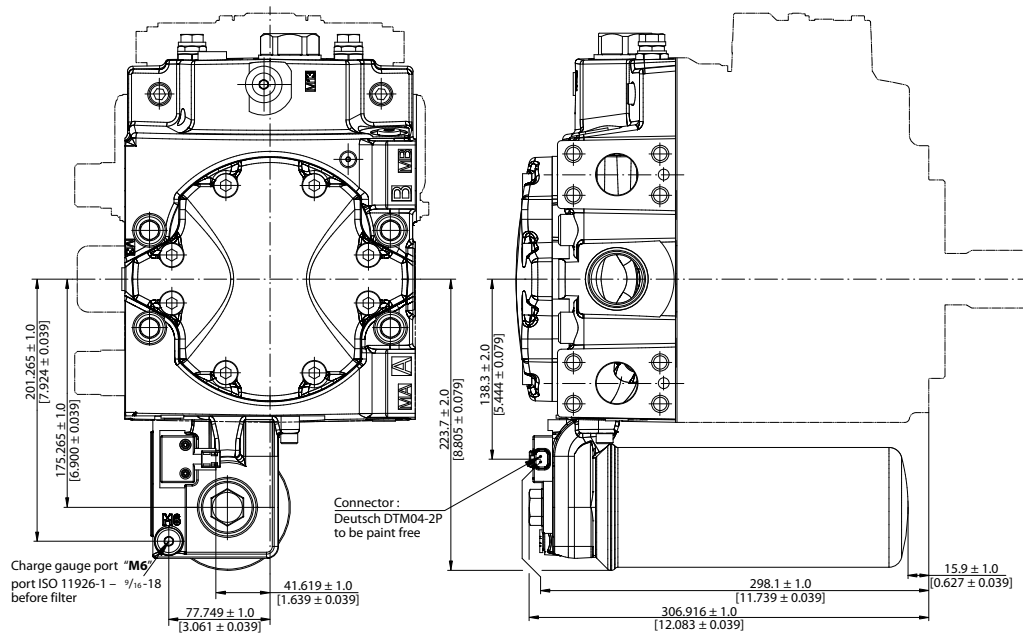

P003 503E

Please contact Danfoss for specific installation drawings.

Technical Information H1 Axial Piston Pump 115/130 147/165 ISL Integrated Speed Limitation

Frame 147/165 cm³ Single Pump

Technical specifications

General specifications

Design	Axial piston pump of cradle swashplate design with variable displacement
Direction of rotation	Clockwise, counterclockwise
Pipe connections	Main pressure ports: ISO Split Flange Boss
	Remaining ports: SAE straight thread O-ring boss
Recommended installation position	Pump installation position is discretionary, however the recommended control position is on the top or at the side. If the pump is installed with the control at the bottom, it is recommended to flush the case through port M14 located at the EDC control. Vertical input shaft installation is acceptable. Consult Danfoss for non conformance to these guidelines. The housing must always be filled with hydraulic fluid.
Auxiliary cavity pressure	Will see inlet pressure with internal charge pump. Will be case pressure with external charge supply. Please verify mating pump shaft seal capability.

Physical properties

Feature	Unit	Frame size	
		147	165
Displacement	cm ³ [in ³]	147 [8.97]	165 [10.07]
Flow at rated (continuous) speed	l/min [US gal/min]	441 [117]	495 [131]
Torque at maximum displacement (theoretical)	N·m/bar [lbf·in/1000psi]	2.34 [1430]	2.63 [1605]
Mass moment of inertia of rotating components	kg·m ² [slug·ft ²]	0.027 [0.0199]	
Weight dry (without PTO and filter)	kg [lb]	96 [211]	
Oil volume	liter [US gal]	3.0 [0.8]	
Mounting flange	SAE flange, size D (SAE J 744) mounting pad		
Auxiliary mounting	SAE A, SAE B, SAE B-B, SAE C, SAE D		
Shafts	Splined: 27-teeth 16/32, 13-teeth 8/16		
Suction ports	1.625-12UN-2B [1 5/8 -12UN-2B]		
Main port configuration	Ø31.5 - 450 bar split flange boss per ISO 6162, M12x1.75		
Case drain ports L1, L3 (SAE O-ring boss) Case drain ports L2, L4 (SAE O-ring boss) preferred usage	1.0625-12UNF-2B [1 1/16 -12UNF-2B] 1.3125-12UNF-2B [1 5/16 -12UNF-2B]		
Other ports	SAE O-ring boss. See Installation drawings.		
Customer interface threads	Metric fastener		

Operating parameters

Feature	Unit	Frame size		
		147	165	
Input speed	Minimum for internal charge supply	min ⁻¹ (rpm)		
	Minimum for external charge supply			
	Minimum for full performance			
	Rated			
	Maximum			
System pressure	Application pressure	bar [psi]	450 [6525]	400 [5800]

Technical Information H1 Axial Piston Pump 115/130 147/165 ISL Integrated Speed Limitation

Frame 147/165 cm³ Single Pump

Operating parameters (continued)

Feature		Unit	Frame size	
			147	165
	Maximum working pressure		480 [6960]	450 [6525]
	Minimum pressure		10 [150]	
Charge pressure	Minimum	bar [psi]	16 [232]	
	Maximum		34 [493]	
Control pressure	Minimum (at corner power)	bar [psi]	17 [247]	
	Maximum		40 [580]	
Charge pump inlet pressure	Rated	bar (absolute) [in Hg vacuum]	0.7 [9]	
	Minimum (cold start)		0.2 [24]	
	Maximum	bar [psi]	4.0 [58]	
Case Pressure	Rated	bar [psi]	3.0 [44]	
	Maximum		5.0 [73]	

Fluid Specifications

Feature		Unit	Frame size	
			147	165
Viscosity	Minimum	mm ² /s [SUS]	7 [49]	
	Recommended range		12-80 [66-370]	
	Maximum		1600 [7500]	
Temperature range ¹⁾	Minimum	°C [°F]	-40 [-40]	
	Rated		104 [220]	
	Maximum intermittent		115 [240]	
Filtration (recommended minimum)	Cleanliness per ISO 4406		22/18/13	
	Efficiency (charge pressure filtration)	β-ratio	β ₁₅₋₂₀ = 75 (β ₁₀ ≥ 10)	
	Efficiency (suction and return line filtration)		β ₃₅₋₄₅ = 75 (β ₁₀ ≥ 2)	
	Recommended inlet screen mesh size	µm	100 – 125	

¹⁾ At the hottest point, normally case drain port.

Model code

A B D F E G H J K M N S T V W X Y
H1 P **A**

Displacement

147	147 cm ³ [8.97 in ³]
165	165 cm ³ [10.06 in ³]

A Rotation

L	Left hand (counter clockwise)
R	Right hand (clockwise)

Technical Information H1 Axial Piston Pump 115/130 147/165 ISL Integrated Speed Limitation

Frame 147/165 cm³ Single Pump
B Product version

A	Revision code
---	---------------

D Control

A2	Electric Displacement Control (EDC) 12V, Deutsch connector
A3	Electric Displacement Control (EDC) 24V, Deutsch connector
A4	Electric Displacement Control (EDC) 12V, Deutsch connector, manual override
A5	Electric Displacement Control (EDC) 24V, Deutsch connector, manual override

F Orifices

C1	Orifices, 0.8 mm in servo supply 1 and 2
C2	Orifices, 1.3 mm in servo supply 1 and 2 (standard)

E Displacement limiters

N	None
B	Adjustable, factory set to max. displacement

G Endcap options

	Twin port, 4-bolt split flange (code 62)	
Match with below options (K)	Auxiliary mounting pad none, SAE-A, B, B-B, C	
Match with below options (T)	Suction filtration	Integral full charge flow filtration
D4		X
E8	X	

H Mounting

G	SAE D 4-bolt
---	--------------

J Input shaft

G3	13 teeth splined shaft 8/16 pitch
G2	27 teeth splined shaft 16/32 pitch

K Auxiliary mounting pad (align with endcap selection, option G)

NN	None
H2	SAE A pad, 9 teeth 16/32 coupling, shipping cover
H1	SAE A-A pad, 11 teeth 16/32 coupling, shipping cover
H3	SAE B pad, 13 teeth 16/32 coupling, shipping cover
H5	SAE B-B pad, 15 teeth 16/32 coupling, shipping cover
H6	SAE C pad, 14 teeth 12/24 coupling, shipping cover

Technical Information H1 Axial Piston Pump 115/130 147/165 ISL Integrated Speed Limitation
Frame 147/165 cm³ Single Pump

M Overpressure protection type and setting side "A" **

N Overpressure protection type and setting side "B" **

** Pressure Protection Type must be the same for side "A" and "B"

L	High pressure relief valve + pressure limiters with bypass
L15	150 bar [2180 psi]
L20	200 bar [2900 psi]
L23	230 bar [3336 psi]
L25	250 bar [3630 psi]
L28	280 bar [4061 psi]
L30	300 bar [4350 psi]
L33	330 bar [4786 psi]
L35	350 bar [5080 psi]
L38	380 bar [5510 psi]
L40	400 bar [5800 psi]
L42	420 bar [6090 psi] (147cm ³ only)
L43	430 bar [6237 psi] (147cm ³ only)
L44	440 bar [6382 psi] (147cm ³ only)
L45	450 bar [6960 psi] (147cm ³ only)

S Charge pump

A	26 cm ³ /rev [1.57 in ³]
L	34 cm ³ /rev [2.07 in ³]

T Filtration options (align with endcap selection, option G)

L	Suction filtration (see basic drawings)
M	Integral full charge flow filtration with bypass sensor and bypass

V Charge pressure relief setting

20	20 bar [290 psi]
24	24 bar [348 psi]
30	30 bar [435 psi]

W Special hardware features

NN	None
----	------

X Paint and nametag

NNN	Black paint and Danfoss nametag
-----	---------------------------------

Frame 147/165 cm³ Single Pump
Y Special settings

G14	ISL Pressure setting 140 bar [2031 psi]
G18	ISL Pressure setting 180 bar [2610 psi]
G21	ISL Pressure setting 210 bar [3046 psi]
G23	ISL Pressure setting 230 bar [3335 psi]
G25	ISL Pressure setting 250 bar [3630 psi]

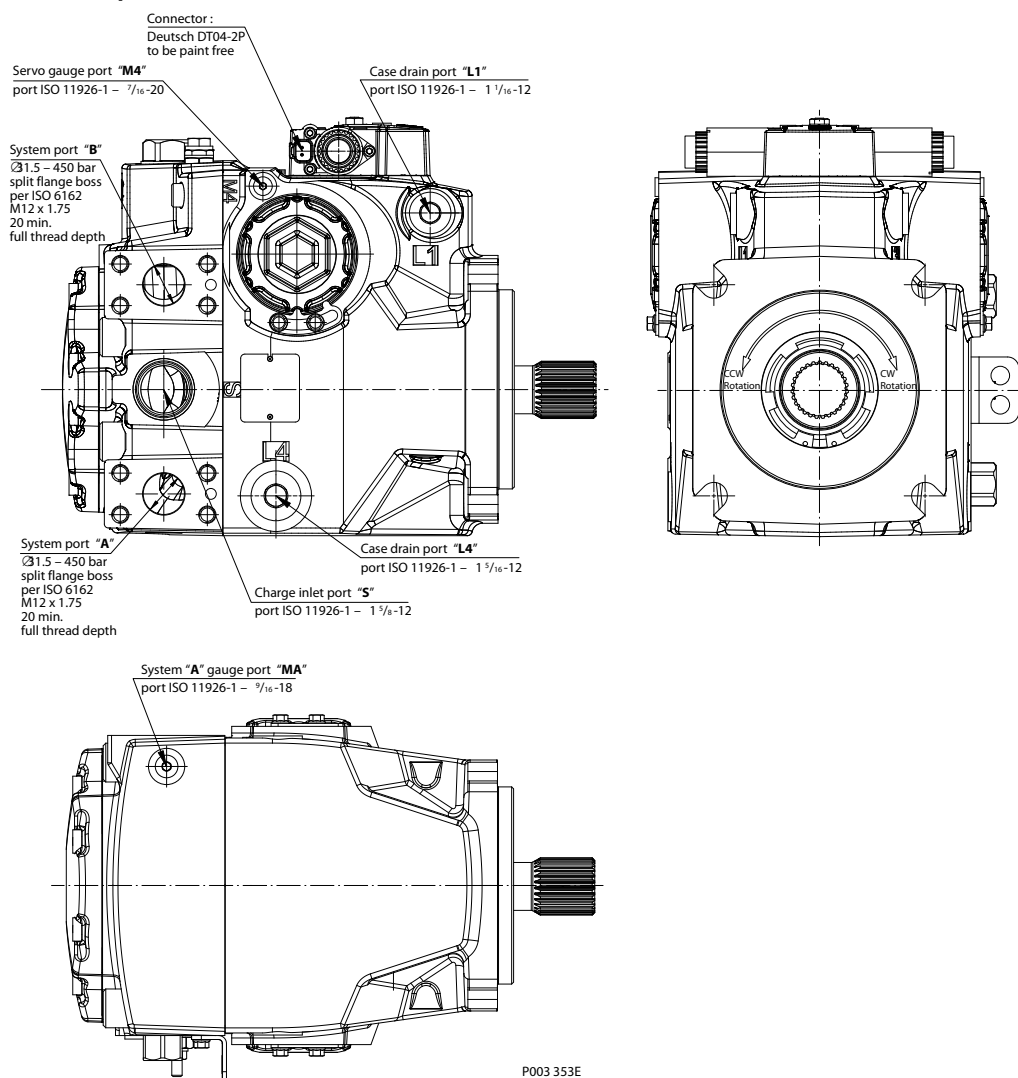
Installation Drawings
Port description

Port description

Port	Description	Sizes
A	System port A	Ø 31.5
B	System port B	Ø 31.5

Frame 147/165 cm³ Single Pump
Port description (continued)

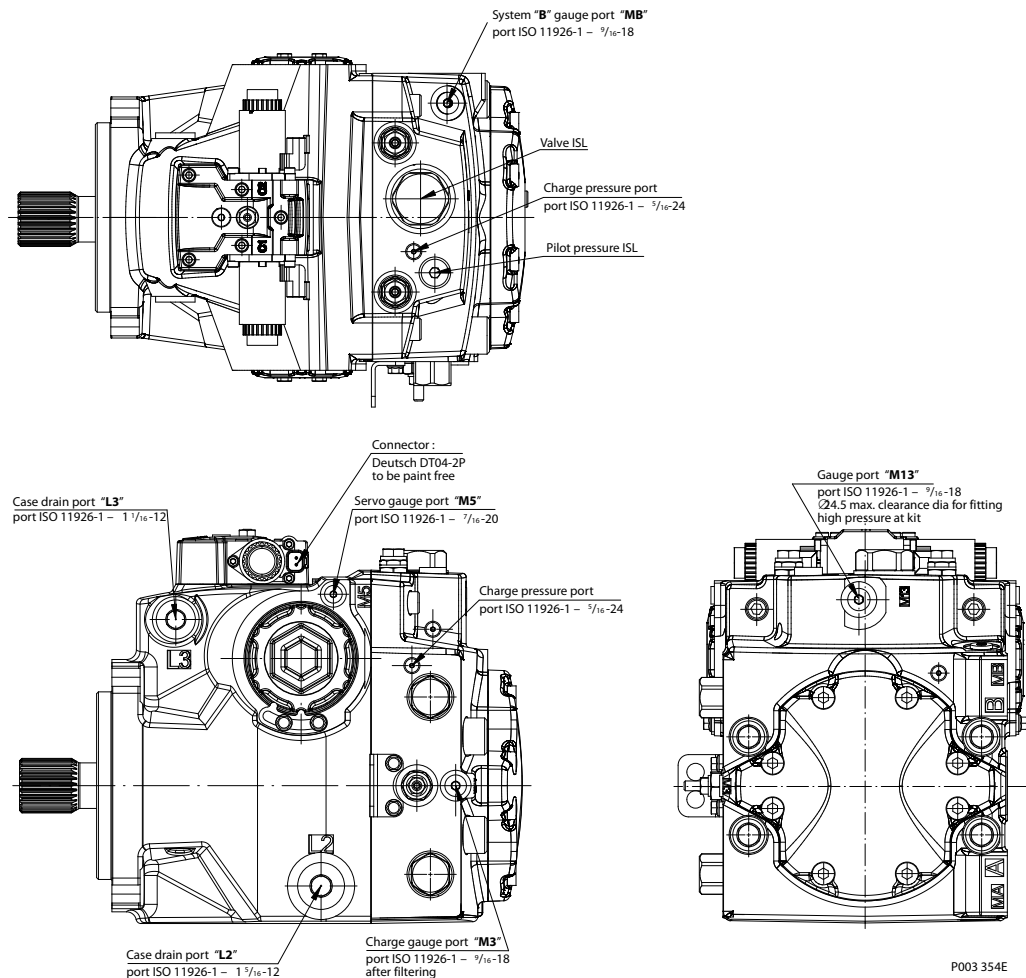
Port	Description	Sizes
E	Charge filtration port, from filter	7/8-14
F	Charge filtration port, to filter	7/8-14
L1	Case drain port	1 1/16-12
L2	Case drain port	1 5/16-12
L3	Case drain port	1 1/16-12
L4	Case drain port	1 5/16-12
MA	System A gage port	9/16-18
MB	System B gage port	9/16-18
M3	Charge gage port, after filtering	9/16-18
M4	Servo gage port	7/16-20
M5	Servo gage port	7/16-20
M14	Case gage port	7/16-20
S	Charge inlet port	1 5/8-12
M13	Gage port, high pressure at Kit	9/16-18



Frame 147/165 cm³ Single Pump

Please contact Danfoss for specific installation drawings.

Dimensions

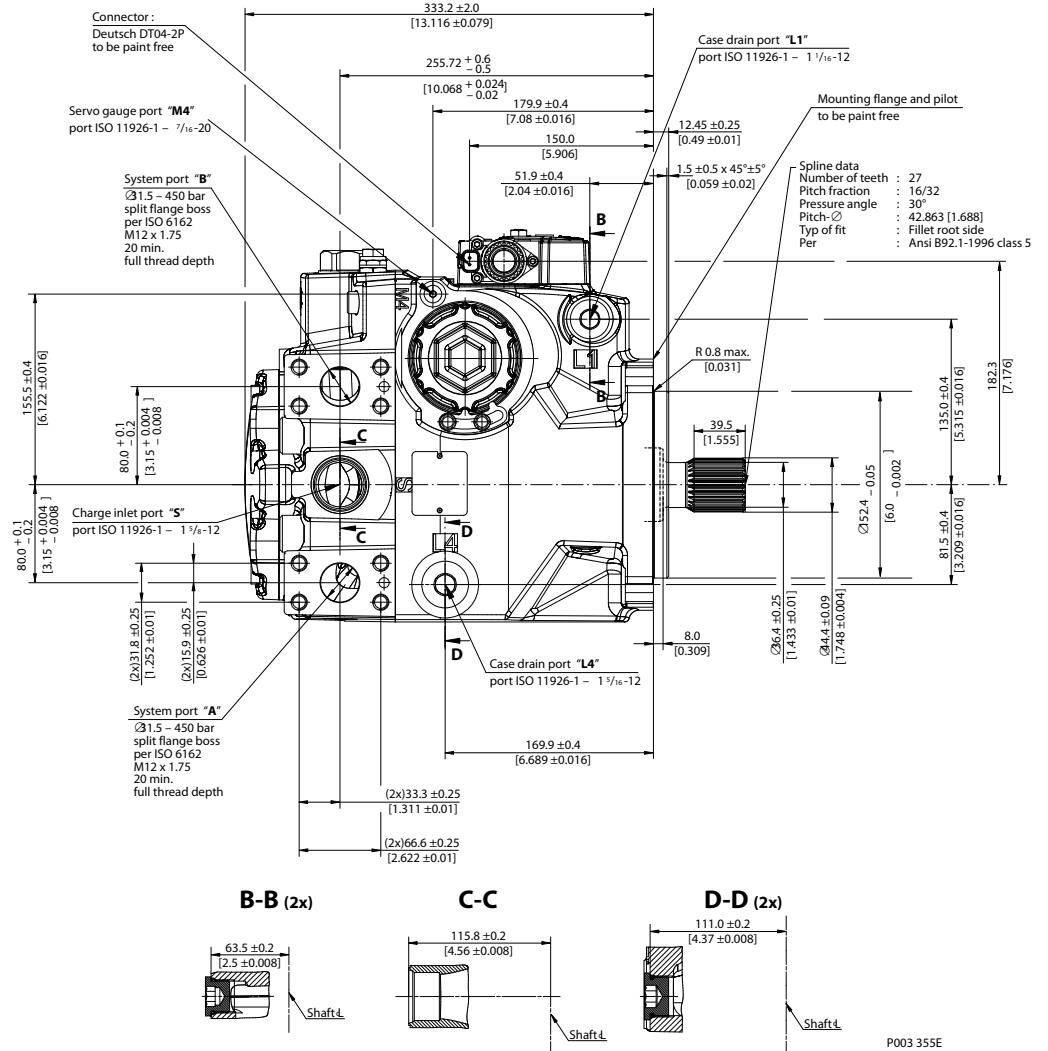

Frame 147/165 cm³ Single Pump

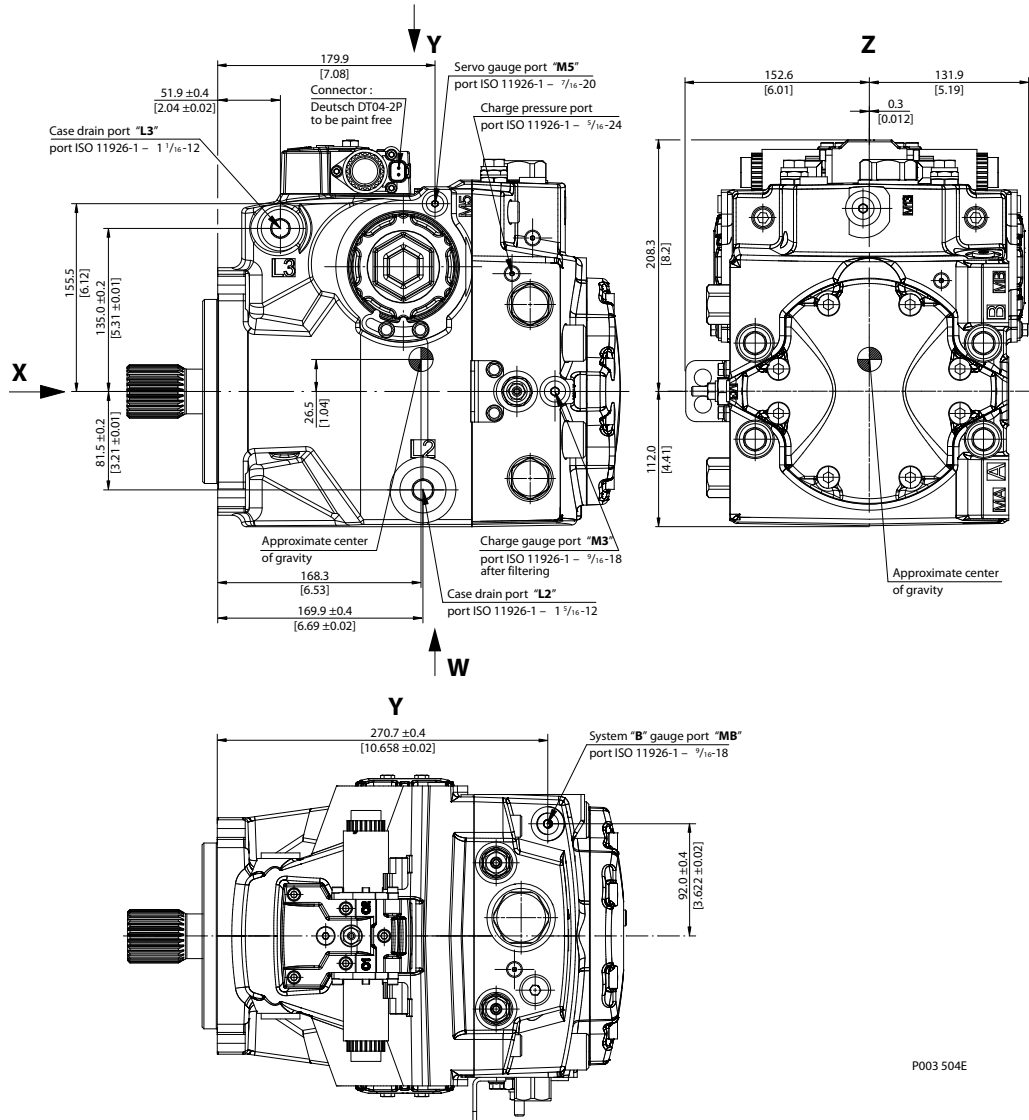

P003 504E

Frame 147/165 cm³ Single Pump

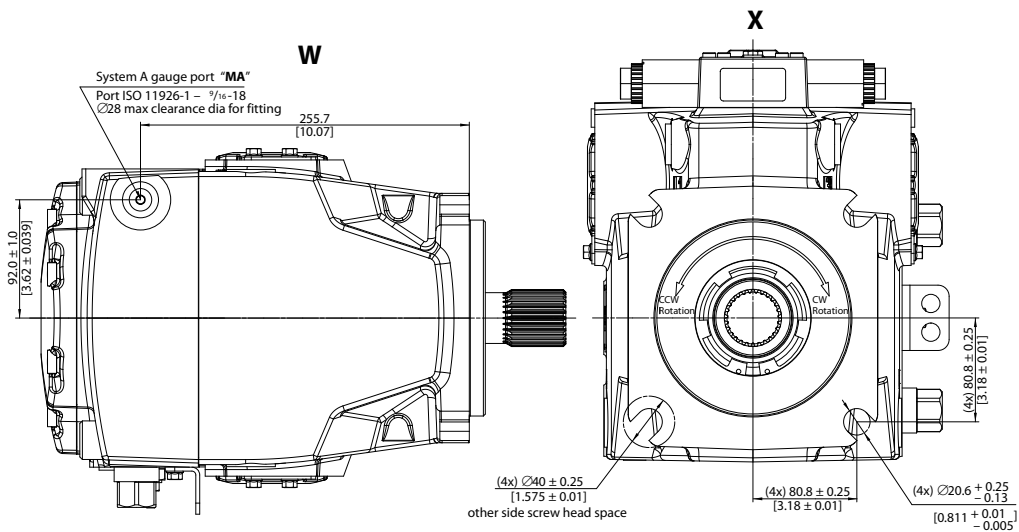

P003 281E

Please contact Danfoss for specific installation drawings.

Controls

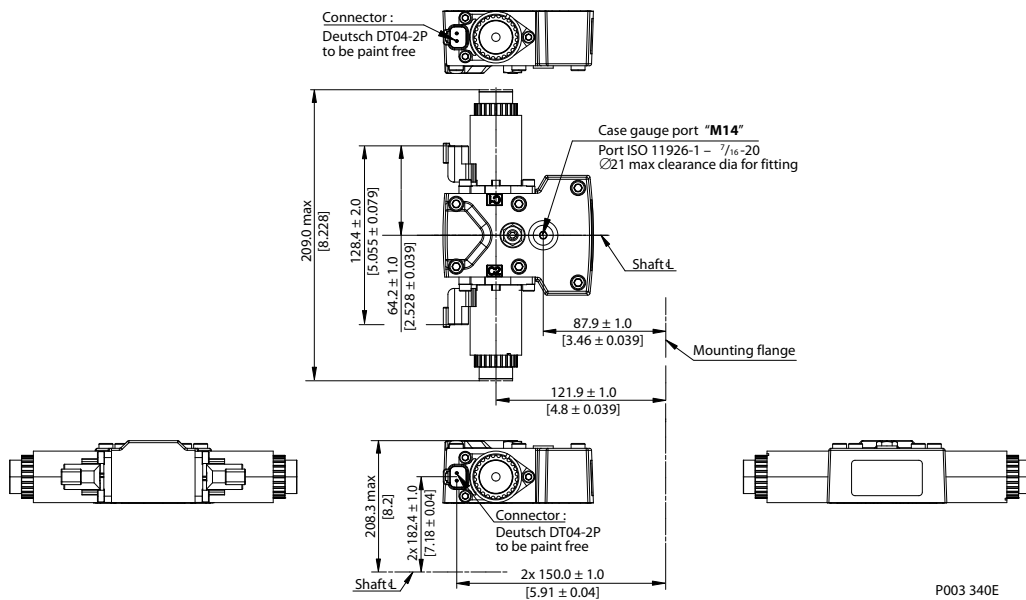

P003 340E

Frame 147/165 cm³ Single Pump

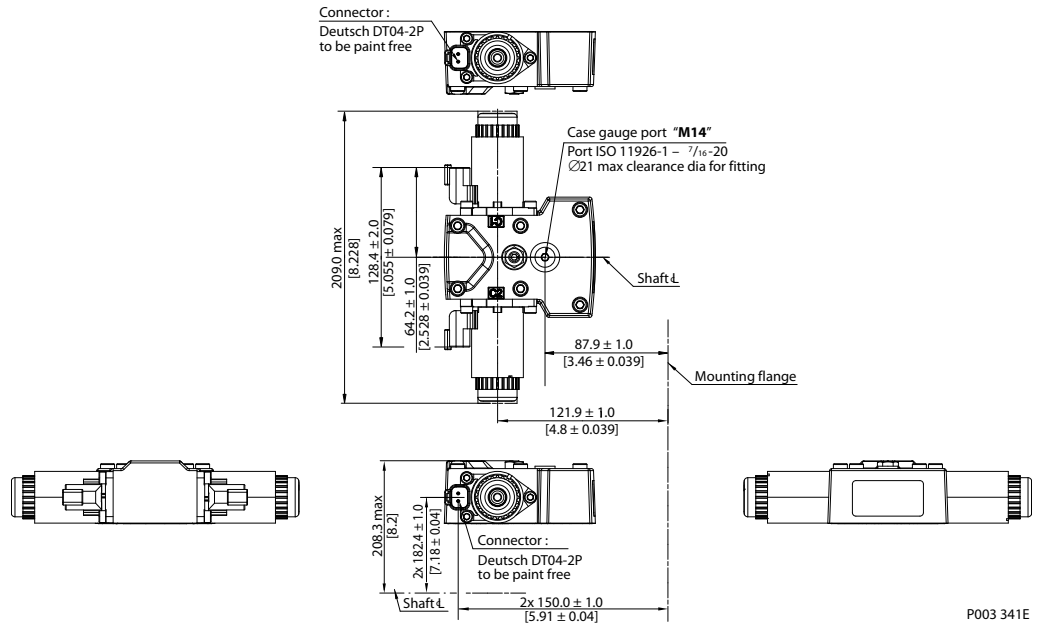

Please contact Danfoss for specific installation drawings.

Frame 147/165 cm³ Single Pump

Filtration

Suction filtration, option L

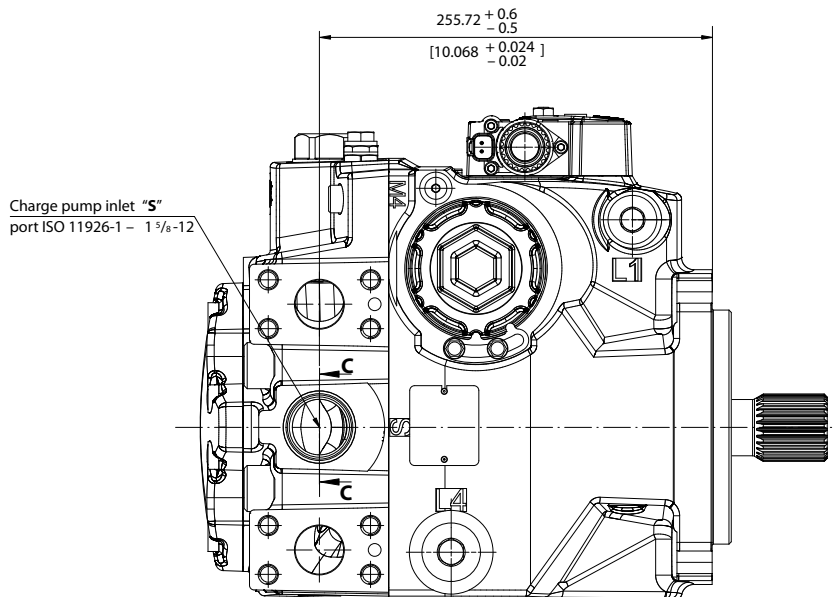

C-C

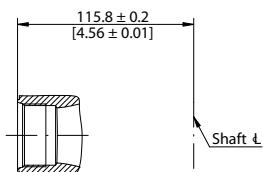

P003 505E

Please contact Danfoss for specific installation drawings.

Frame 147/165 cm³ Single Pump

Integral full flow charge pressure filtration with filter bypass sensor, option M

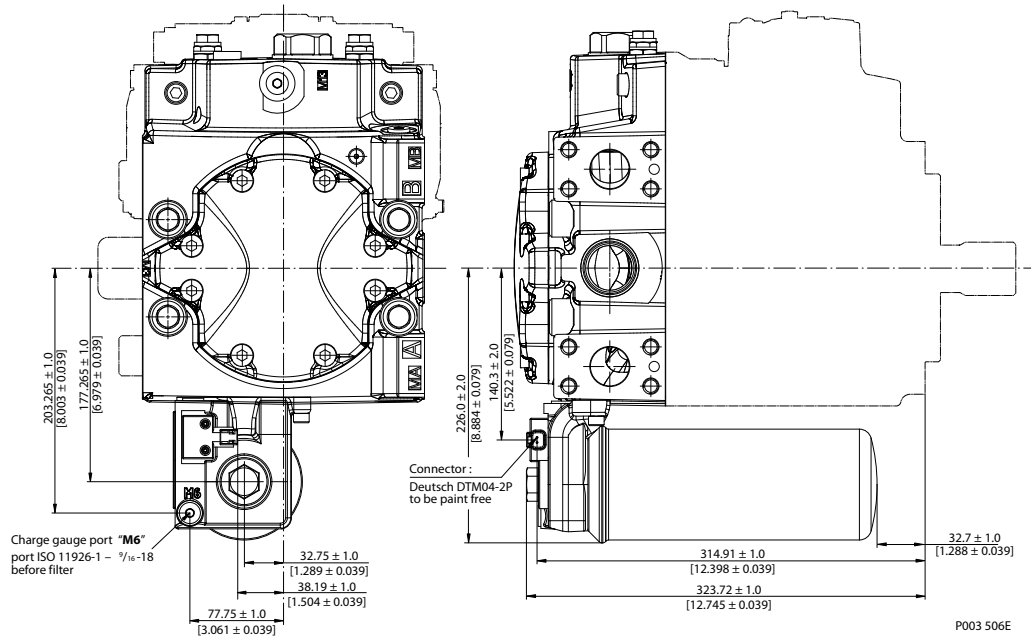

Please contact Danfoss for specific installation drawings.



Products we offer:

- Bent Axis Motors
- Closed Circuit Axial Piston Pumps and Motors
- Displays
- Electrohydraulic Power Steering
- Electrohydraulics
- Hydraulic Power Steering
- Integrated Systems
- Joysticks and Control Handles
- Microcontrollers and Software
- Open Circuit Axial Piston Pumps
- Orbital Motors
- PLUS+1® GUIDE
- Proportional Valves
- Sensors
- Steering
- Transit Mixer Drives

Danfoss Power Solutions is a global manufacturer and supplier of high-quality hydraulic and electronic components. We specialize in providing state-of-the-art technology and solutions that excel in the harsh operating conditions of the mobile off-highway market. Building on our extensive applications expertise, we work closely with our customers to ensure exceptional performance for a broad range of off-highway vehicles.

We help OEMs around the world speed up system development, reduce costs and bring vehicles to market faster.

Danfoss – Your Strongest Partner in Mobile Hydraulics.

Go to www.powersolutions.danfoss.com for further product information.

Wherever off-highway vehicles are at work, so is Danfoss.

We offer expert worldwide support for our customers, ensuring the best possible solutions for outstanding performance. And with an extensive network of Global Service Partners, we also provide comprehensive global service for all of our components.

Please contact the Danfoss Power Solution representative nearest you.

Comatrol

www.comatrol.com

Schwarz Müller-Inverter

www.schwarzmueller-inverter.com

Turolla

www.turollaocg.com

Valmova

www.valmova.com

Hydro-Gear

www.hydro-gear.com

Daikin-Sauer-Danfoss

www.daikin-sauer-danfoss.com

Local address:

Danfoss Power Solutions US Company
2800 East 13th Street
Ames, IA 50010, USA
Phone: +1 515 239 6000

Danfoss Power Solutions GmbH & Co. OHG
Krokamp 35
D-24539 Neumünster, Germany
Phone: +49 4321 871 0

Danfoss Power Solutions ApS
Nordborgvej 81
DK-6430 Nordborg, Denmark
Phone: +45 7488 2222

Danfoss Power Solutions (Shanghai) Co. Ltd.
Building #22, No. 1000 Jin Hai Rd
Jin Qiao, Pudong New District
Shanghai, China 201206
Phone: +86 21 3418 5200

Danfoss can accept no responsibility for possible errors in catalogues, brochures and other printed material. Danfoss reserves the right to alter its products without notice. This also applies to products already on order provided that such alterations can be made without subsequential changes being necessary in specifications already agreed. All trademarks in this material are property of the respective companies. Danfoss and the Danfoss logotype are trademarks of Danfoss A/S. All rights reserved.