

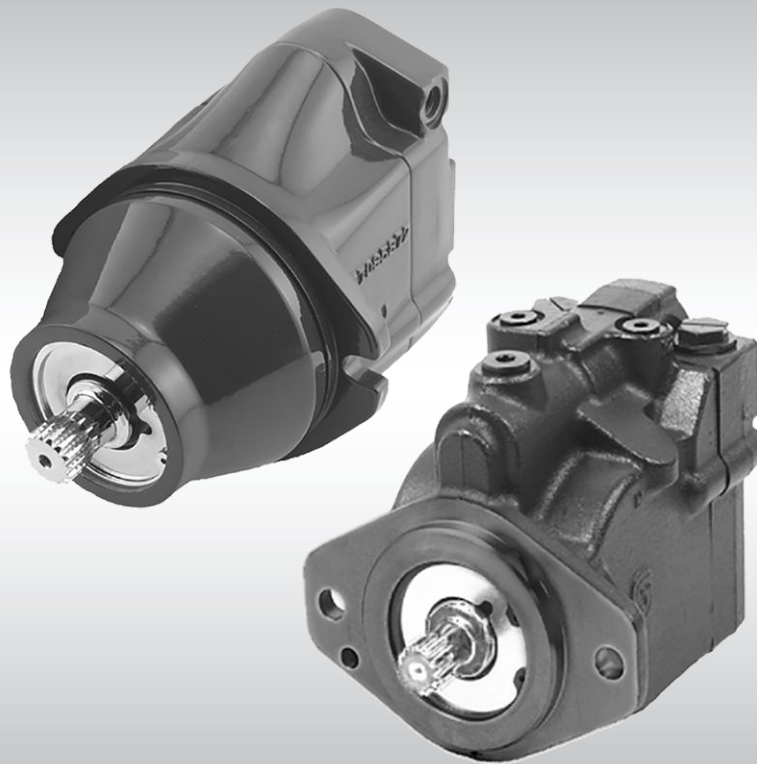

Technical Information

# L and K Frame Variable Motors



**Revision History***Table of Revisions*

<b>Date</b>	<b>Changed</b>	<b>Rev</b>
January 2014	Danfoss layout	CA
July 2013	corrections to the schematics	BI
June 2013	add HIC and anticavitation options	BH
October 2012	edits to various pages	BG
September 2009	L35 Max. pressure 300 bar [4350 psi], and speed ring pulses L = 41, K = 44	BF
April 2008	corrected the schematic drawings	BE
January 2008	removed displacement limiter setting F12 - 65.3%	BD
April 2007	LV (41 pulses/rev) KV (44 pulses/rev)	BC
March 2007	changed 41 pulses/rev to 44 pulses/rev	BB
October 2006	Added Loop flushing valve and 5 bolt endcap	B
February 2004	First edition	A

**Contents**
**General Information**

Basic Design.....	5
Key Features.....	6
System Circuit Diagram.....	6
Schematic Diagrams.....	7

**Technical Specifications**

Overview.....	8
Features and Options.....	8
Specifications.....	8
Operating Parameters.....	8
Fluid Specifications.....	9

**Operating Parameters**

Fluids.....	10
Viscosity.....	10
Temperature.....	10
Charge Pressure/Open Circuit Operation.....	10
Case Pressure.....	11
Shift Pressure.....	11
System Pressure.....	11
Input Speed.....	11

**System Design Parameters**

Installation.....	13
Filtration.....	13
Reservoir.....	13
Overpressure Protection.....	13
Loop Flushing.....	13
Charge Flow.....	13
Charge Pressure / Open Circuit Operation.....	14
Redundant Braking System Requirement.....	14
Series Operation.....	14
Shaft Loads.....	14
Radial load formula.....	14
Duty Cycle and Bearing Life.....	15
Hydraulic Equations Helpful for Motor Selection.....	15
Name Plate.....	16
Serial number.....	16
Model number.....	16
Model code.....	16

**Product Coding**

Model Code.....	17
-----------------	----

**Features and Options**

Speed Sensor.....	20
Shaft Torque.....	20
Shaft torque and spline lubrication.....	20
Shaft torque for tapered shafts.....	21
Output Shafts.....	21
Loop Flushing.....	24
Anti-Cavitation Valve Option.....	25
Dust Seal Option.....	26
Displacement Limiters.....	27
Motor Rotation.....	27
Controls.....	27
Control orificing.....	27
Brake Release Port (cartridge motors).....	28

**Contents**

**Installation Drawings**

SAE-B Mount (LV/KV).....	29
Cartridge (LC/KC).....	34

**General Information**
**Basic Design**

The L and K Frame variable motors are light to medium power two-position axial piston motors incorporating an integral servo piston. They are designed for operation in closed and open circuit applications. The L and K Frame motors consist of five unique rotating groups (displacements) and two housing (mounting) configurations. An SAE-B, two-bolt, and a cartridge style (for space-optimized gearbox mounting) configurations are available for each frame. Maximum speeds and maximum applied pressures for each displacement vary. The standard control is a direct acting single line hydraulic control. For SAE-B mount motors a two line control is also available. The integral servo piston controls motor displacement.

The motor is spring biased to maximum displacement and hydraulically shifted to minimum displacement. Minimum and maximum displacement can be set with fixed internal stops. The large diameter servo piston allows smooth acceleration and deceleration with relatively large circuit orificing.

The motor is ideally configured for installations requiring compact packaging and optimized plumbing, such as wheel ends. One face of the motor contains all hydraulic porting. Two standard porting configurations are available: twin radial (side) or axial (end) O-ring boss main ports.

*Cross section, SAE-B mount*

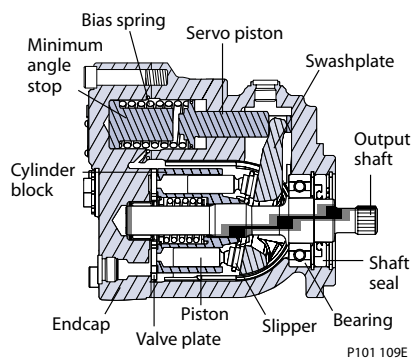

*Cross section, cartridge mount*

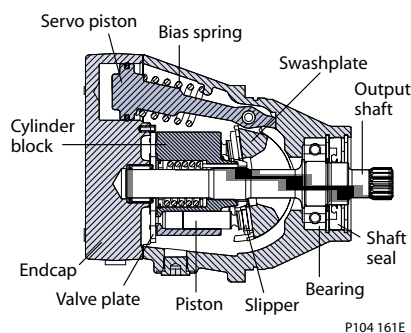

**General Information**

**Key Features**

- Five displacements allow the optimum selection of hydraulic motor for the lowest possible installed cost.
- SAE-B, two-bolt, and cartridge mounting configurations available.
- Short and compact; fits into existing installation with improved porting.
- Three clean sides with superior clearance and access to mounting bolts.
- High Efficiency - nine piston rotating groups with 18 degree maximum angle.
- Versatility - working displacement range of 3.4:1 with a minimum angle option to one degree overcenter (-1°).
- Reliability - uses existing and proven technology.
- Worldwide service and technical support.

**System Circuit Diagram**

*Pictorial system diagram*

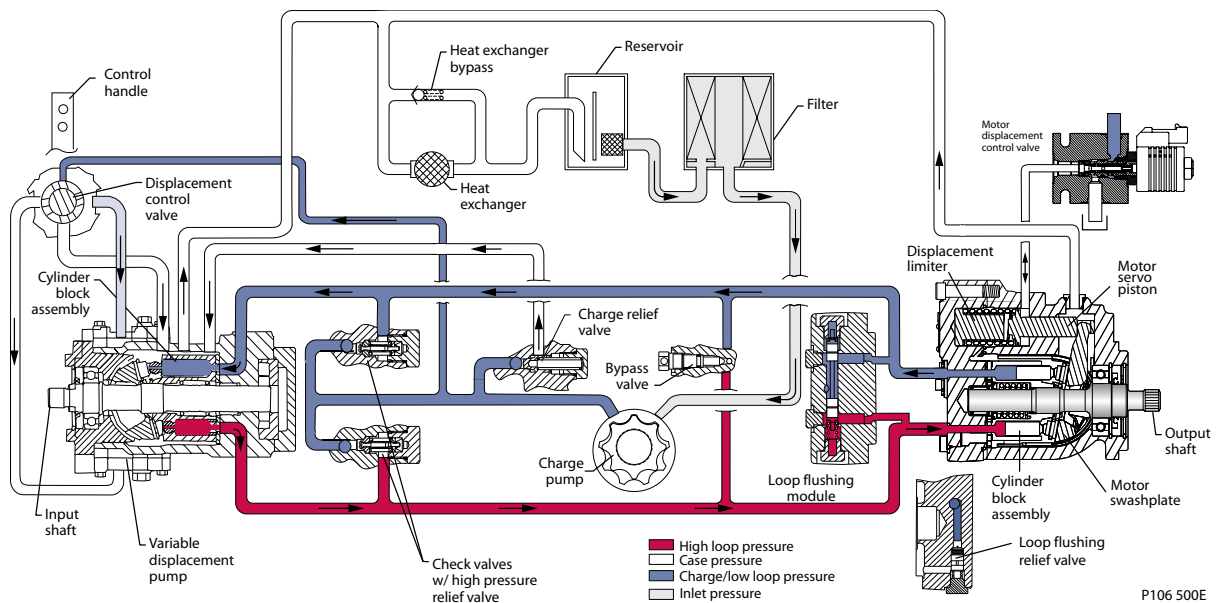

The circuit above shows the LV/KV motor in a simple closed-loop hydrostatic propel application. The motor is driven by a Series 40 M46 axial piston pump with manual displacement control. The motor shown uses a single line hydraulic displacement control. Control pressure applied through an external control valve shifts the motor to minimum displacement, spring force returns the motor to maximum displacement in the absence of control input.

**Technical Information L and K Frame Variable Motors**

**General Information**

**Schematic Diagrams**

*SAE motor - single or two line control*

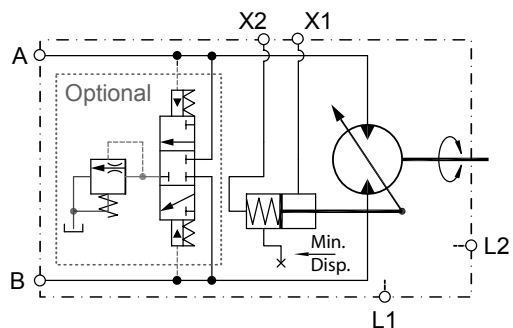

P107 785

*Cartridge motor - single line control*

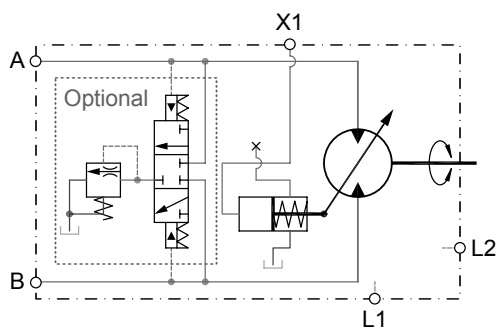

P107 784

## Technical Information L and K Frame Variable Motors

### Technical Specifications

#### Overview

Specifications and operating parameters for L and K Frame motors are given here for quick reference. For additional information, see [Operating Parameters](#) on page 8, [Features and Options](#) on page 8, and [Product Coding](#) on page 17.

#### Features and Options

Mount	SAE-B (LV/KV)	Cartridge (LC/KC)
Motor type	Inline, axial piston, positive displacement, two-speed variable motors	
Displacement	L: 25, 30, or 35 cm <sup>3</sup> [1.50, 1.83, or 2.14 in <sup>3</sup> ] K: 38 or 45 cm <sup>3</sup> [2.32 or 2.75 in <sup>3</sup> ]	
Rotation	Bidirectional	
Installation position	Discretionary: Housing must always be filled with hydraulic fluid	
Porting	SAE O-ring boss, axial or twin radial	SAE O-ring boss, twin radial
Output shafts	Splined 13 or 15 tooth 16/32 pitch, 0.875 inch straight keyed, and 1:8 taper	Splined 13 or 15 tooth 16/32 pitch
Control options	Single or dual line hydraulic control	Single line hydraulic control
Displacement limiter	Fixed maximum and minimum displacement limiters available	
Speed sensor	Available - refer to Features and options section	
Loop Flushing Valve	Available - refer to Features and options section	

#### Specifications

Parameter	Unit	L25	L30	L35	K38	K45
Displacement (maximum)	cm <sup>3</sup> [in <sup>3</sup> ]	25 [1.50]	30 [1.83]	35 [2.14]	38 [2.32]	45 [2.75]
Weight (cartridge and SAE-B)	kg [lb]	15.4 [34]				
Mass moment of inertia of rotating components	kg·m <sup>2</sup> [slug·ft <sup>2</sup> ]	0.0017 [0.0012]	0.0016 [0.0012]	0.0015 [0.0011]	0.0023 [0.0017]	0.0023 [0.0017]
Theoretical torque	N·m/bar [lbf·in/1000psi]	0.40 [244]	0.48 [293]	0.56 [347]	0.60 [366]	0.72 [439]

#### Operating Parameters

Parameter		Unit	L25	L30	L35	K38	K45
System pressure	maximum working	bar [psi]	400 [5800]	350 [5075]	300 [4350]	350 [5075]	300 [4350]
	maximum		420 [6090]	375 [5440]	325 [4715]	415 [6020]	350 [5075]
Speed limit (at max. disp..)	rated	min <sup>-1</sup> (rpm)	3400	3500	3600	3600	3500
	maximum		3950	4150	4300	4000	3900
Speed limit (at min. disp., including Zero degrees)	rated		4400	4450	4500	4650	4500
	maximum		5000	5150	5300	5200	5050
Case pressure	maximum working	bar [psi]	2 [29]				
	maximum		6 [87]				
Shift pressure (single line control)	maximum working	bar [psi]	14 [203]				
	maximum		69 [1000]				



---

**Technical Information    L and K Frame Variable Motors**

---

**Technical Specifications**
**Fluid Specifications**

Parameter	Unit	Minimum	Continuous	Maximum
Viscosity	mm <sup>2</sup> /sec (cSt) [SUS]	7 [47]	12-60 [70-278]	1600 [7500]
Temperature	°C [°F]	-40 [-40]	82 [180]	104 [220]
Cleanliness	ISO 4406 Class 18/13 or better			
Filtration efficiency	suction filtration	$\beta_{35-44}=75$ ( $\beta_{10} \geq 1.5$ )		
	charge filtration	$\beta_{15-20}=75$ ( $\beta_{10} \geq 10$ )		

---

Ratings and data are based on operation with premium petroleum-based hydraulic fluids containing oxidation, rust, and foam inhibitors.

---

**Operating Parameters**
**Fluids**

Ratings and performance data for L and K Frame motors are based on operating with premium hydraulic fluids containing oxidation, rust, and foam inhibitors. These include premium turbine oils, API CD engine oils per SAE J183, M2C33F or G automatic transmission fluids (ATF), Dexron II (ATF) meeting Allison C-3 or Caterpillar T0-2 requirements, and certain specialty agricultural tractor fluids. For more information on hydraulic fluid selection, see Danfoss publications: *Hydraulic Fluids and Lubricants, Technical Information, 520L0463*, and *Experience with Biodegradable Hydraulic Fluids, Technical Information, 520L465*.

**Viscosity**

Maintain fluid viscosity within the recommended range for maximum efficiency and bearing life. **Minimum viscosity** should only occur during brief occasions of maximum ambient temperature and severe duty cycle operation. **Maximum viscosity** should only occur at cold start. Limit speeds until the system warms up.

*Fluid viscosity limits*

Condition	mm <sup>2</sup> /s (cSt)	SUS
Minimum	7	47
Continuous	12-60	70-278
Maximum	1600	7500

**Temperature**

Maintain fluid temperature within the limits shown in the table. **Minimum temperature** relates to the physical properties of the component materials. Cold oil will not affect the durability of the motor components. However, it may affect the ability of the motor to transmit power. **Maximum temperature** is based on material properties. Don't exceed it. Measure maximum temperature at the hottest point in the system. This is usually the case drain.

*Temperature limits*

Minimum (intermittent, cold start)	- 40° C [- 40° F]
Continuous	85° C [185° F]
Maximum	105° C [221° F]

---

Ensure fluid temperature and viscosity limits are concurrently satisfied.

---

**Charge Pressure/Open Circuit Operation**

L and K Frame motors can be operated in closed and open circuit applications. For a propel motor open circuit, the motor must have a direct line (no combining flows) from the motor case to the reservoir to prevent pressure spikes. When the motor is being operated with zero backpressure, the maximum limit for case pressure is 2 bar.

---

**Technical Information L and K Frame Variable Motors**

---

**Operating Parameters**
**Case Pressure**

Maintain case pressure within the limits shown in the table. The housing must always be filled with hydraulic fluid.

**! Caution**

Operating outside of charge and case pressure limits will damage the motor. To minimize this risk, use full size inlet and case drain plumbing, and limit line lengths.

---

*Case pressure limits*

Maximum (continuous)	2 bar [29 psi]
Intermittent (cold start)	6 bar [87 psi]

**Shift Pressure**

Minimum shift pressure required to keep motor swashplate at minimum angle is 14 bar [203 psi].

*Control input pressure limits*

LV/KV with single line control	14 to 240 bar [200 to 3500 psi]
LV/KV with dual line control	14 to 35 bar [200 to 500 psi]
LC/KC with single line control	14 to 69 bar [200 to 1000 psi]

**System Pressure**

**System pressure** is the differential pressure between high pressure system ports. It is the dominant operating variable affecting hydraulic unit life. High system pressure, which results from high load, reduces expected life. Hydraulic unit life depends on the speed and normal operating, or weighted average, pressure that can only be determined from a duty cycle analysis.

**Application pressure** is the high pressure relief or pressure limiter setting normally defined within the order code of the pump. This is the applied system pressure at which the driveline generates the maximum calculated pull or torque in the application.

**Maximum working pressure** is the highest recommended Application pressure. Maximum working pressure is not intended to be a continuous pressure. Propel systems with application pressures at, or below, this pressure should yield satisfactory unit life given proper component sizing.

**Maximum pressure** is the highest allowable Application pressure under any circumstance. Application pressures above maximum working pressure will only be considered with duty cycle analysis and factory approval.

---

Pressure spikes are normal and must be considered when reviewing maximum working pressure.

---

Minimum low loop pressure must be maintained under all operating conditions to avoid cavitation.

---

All pressure limits are differential pressures referenced to low loop (charge) pressure. Subtract low loop pressure from gauge readings to compute the differential.

---

**Input Speed**

**Minimum speed** is the lowest input speed recommended during engine idle condition. Operating below minimum speed limits the pump's ability to maintain adequate flow for lubrication and power transmission.

**Rated speed** is the highest input speed recommended at full power condition. Operating at or below this speed should yield satisfactory product life.

## Operating Parameters

**Maximum speed** is the highest operating speed permitted. Exceeding maximum speed reduces product life and can cause loss of hydrostatic power and braking capacity. Never exceed the maximum speed limit under any operating conditions.

Operating conditions between rated speed and maximum speed should be restricted to less than full power and to limited periods of time. For most drive systems, maximum unit speed occurs during downhill braking or negative power conditions.

For more information consult *Pressure and Speed Limits*, **BLN-9884**, when determining speed limits for a particular application.

---

During hydraulic braking and downhill conditions, the prime mover must be capable of providing sufficient braking torque in order to avoid pump over speed. This is especially important to consider for turbocharged and Tier 4 engines.

---

### **Warning**

#### **Unintended vehicle or machine movement hazard**

Exceeding maximum speed may cause a loss of hydrostatic drive line power and braking capacity. You must provide a braking system, redundant to the hydrostatic transmission, sufficient to stop and hold the vehicle or machine in the event of hydrostatic drive power loss. The braking system must also be sufficient to hold the machine in place when full power is applied.

---

## System Design Parameters

### Installation

L and K Frame motors may be installed in any position. The motor housing must always remain full of hydraulic fluid.

Fill the motor housing and system lines with clean fluid during installation. Connect the case drain line to the uppermost drain port (L1 or L2) to keep the housing full during operation.

To allow unrestricted flow to the reservoir, use a dedicated drain line. Connect it below the minimum reservoir fluid level and as far away from the reservoir outlet as possible. Use plumbing adequate to maintain case pressure within prescribed limits (see [Case Pressure](#) on page 11).

### Filtration

To prevent damage to the motor, including premature wear, fluid entering the motor must be free of contaminants. L and K Frame motors require system filtration capable of maintaining fluid cleanliness at ISO 4406-1999 class 22/18/13 or better.

Consider these factors when selecting a system filter:

- Cleanliness specifications
- Contaminant ingress rates
- Flow capacity
- Desired maintenance interval

Typically, a filter with a beta ratio of  $\beta_{10} = 1.5$  to 2.0 is adequate. However, open circuit systems supplied from a common reservoir may have considerably higher requirements. Because each system is unique, only a thorough testing and evaluation program can fully validate the filtration system. For more information, see Danfoss publication *Design Guidelines for Hydraulic Fluid Cleanliness*, **520L0467**.

### Reservoir

The reservoir provides clean fluid, dissipates heat, and removes entrained air from the hydraulic fluid. It allows for fluid volume changes associated with fluid expansion and cylinder differential volumes. Minimum reservoir capacity depends on the volume needed to perform these functions. Typically, a capacity of one half the charge pump flow (per minute) is satisfactory for a closed reservoir. Open circuit systems sharing a common reservoir will require greater fluid capacity.

Locate the reservoir outlet (suction line) near the bottom, allowing clearance for settling foreign particles. Place the reservoir inlet (return lines) below the lowest expected fluid level, as far away from the outlet as possible.

### Overpressure Protection

L and K Frame motors have no internal overpressure protection. Therefore, relief valves or pressure limiters are required to maintain system pressure within prescribed limits. Relief valves are adequate to protect against transient or unusually rapid load application, but excessive or continuous flow through them adds heat to the system and can damage the fluid. In applications operating at or near pressure, use a pressure compensating variable pump.

### Loop Flushing

Closed circuit systems may require loop flushing to meet temperature and cleanliness requirements. A loop flushing valve removes hot fluid from the low pressure side of the system loop for additional cooling and filtering. Ensure the charge pump provides adequate flow for loop flushing and the loop flushing valve does not cause charge pressure to drop below recommended limits.

### Charge Flow

Closed circuit applications require a charge pump to make up for lubrication and cooling losses, and to charge the low pressure side of the system loop. The total charge flow required is a sum of the charge flow requirements for the pump, plus the flow requirements for all motors in the system, plus any external loop flushing requirements.

Ensure that adequate charge flow exists under all conditions of engine speed and motor speed and pressure.

**System Design Parameters**
**Charge Pressure / Open Circuit Operation**

L and K frame motors can be operated with zero pressure in the low side of the system loop. The case pressure must not be higher than 2 bar over the low side loop system pressure. With zero backpressure, the maximum allowed case pressure is 2 bar [29 psi]. Case drain lines must be plumbed accordingly to insure this 2 bar case pressure differential is not exceeded under any circumstances.

**Redundant Braking System Requirement**
**Warning**
**Unintended vehicle or machine movement hazard.**

The loss of hydrostatic drive line power, in any mode of operation (forward, neutral, or reverse) may cause the system to lose hydrostatic braking capacity. You must provide a braking system, redundant to the hydrostatic transmission, sufficient to stop and hold the vehicle or machine in the event of hydrostatic drive power loss.

**Series Operation**

L and K Frame motors may be operated in series configuration as long as system, charge, and case pressure limits are satisfied. Operating motors in series significantly impacts bearing life. Contact your Danfoss representative for assistance when applying L and K Frame motors in series configuration.

**Shaft Loads**

L and K Frame motors have bearings capable of accepting some external radial and thrust loads. The external radial shaft load limits are a function of the load position, orientation, and the operating conditions of the motor.

*Shaft external load limits*

Frame		L		K	
		SAE	Cartridge	SAE	Cartridge
Maximum allowable external moment ( $M_e$ )	N·M	7.7	21.7	13.3	37.5
	lbf·in	68	192	118	332
Maximum allowable thrust load (T)	N	750		1100	
	lbf	169		247	

The table above gives the maximum allowable external moment ( $M_e$ ) for a 25% bearing life reduction, with optimum load orientation, operating at maximum continuous pressure (see [Specifications](#) on page 8). You can compute the allowable radial load ( $R_e$ ) from the moment ( $M_e$ ), and the load distance (L) from the mounting flange, using the formula below. The thrust load (T) is the maximum allowable without bearing life reduction, based on the radial load for 25% life reduction and maximum continuous pressure. Maximum allowable thrust load (T) is a function of external radial load and operating pressure, and may or may not impact bearing life. If thrust or radial loads exist that are not a function of the operating load of the motor, or exceed these limits, contact your Danfoss representative for application assistance.

**Radial load formula**

$$M_e = R_e \cdot L$$

L = Distance from mounting flange to point of load

$M_e$  = Maximum external moment

$R_e$  = Maximum radial side load

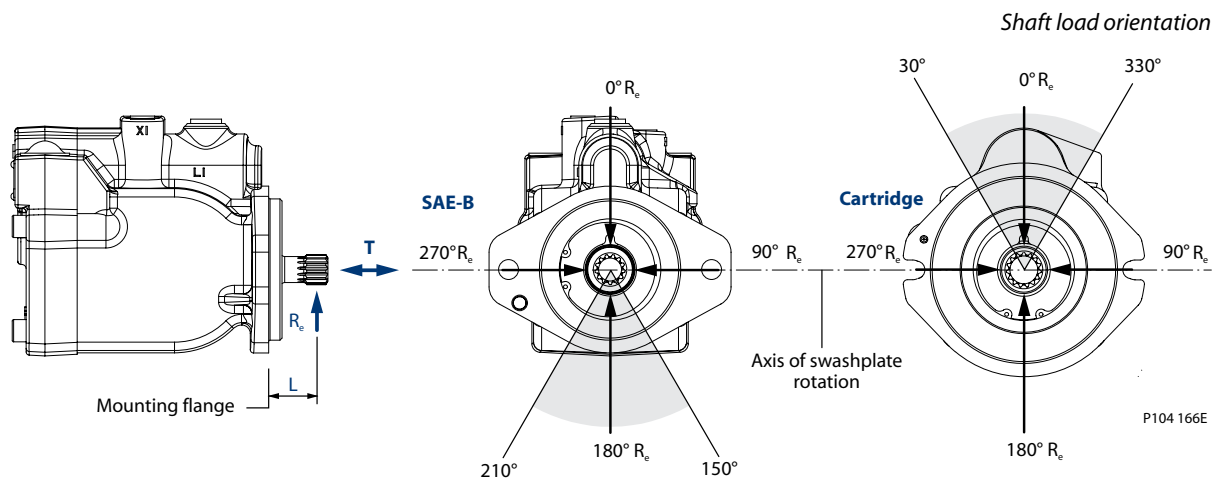
**System Design Parameters**

**Duty Cycle and Bearing Life**

All shaft loads affect bearing life. In applications where external shaft loads exist, maximize bearing life by orientating the load in the optimal position, as shown in the shaded area above. We recommend tapered shafts or clamp-type couplings for applications with radial shaft loads.

Knowing the operating conditions of your application is the best way to ensure proper motor selection. With accurate duty cycle information, your Danfoss representative can assist in calculating expected motor life.

**Hydraulic Equations Helpful for Motor Selection**

Use the following equations to compute output power, torque, speed, and input flow. Selecting the right motor starts with an evaluation of system requirements such as speed and torque. Select a motor that will transmit the required torque, then select a pump that will meet the flow and pressure requirements of the motor. For more information on hydrostatic drive selection, refer to Danfoss applications guideline *Selection of Drive Line Components*, **BLN-9885**.

**Based on SI units**

$$\text{Input flow } Q = \frac{V_g \cdot n}{1000 \cdot \eta_v} \quad (\text{l/min})$$

$$\text{Motor speed } n = \frac{Q \cdot 1000 \cdot \eta_v}{V_g} \quad \text{min}^{-1}(\text{rpm})$$

$$\text{Output torque } M = \frac{V_g \cdot \Delta p \cdot \eta_m}{20 \cdot \pi} \quad (\text{N}\cdot\text{m})$$

$$\text{Output power } P = \frac{Q \cdot \Delta p \cdot \eta_t}{600} \quad (\text{kW})$$

**Based on US units**

$$\text{Input flow } Q = \frac{V_g \cdot n}{231 \cdot \eta_v} \quad (\text{US gal/min})$$

$$\text{Motor speed } n = \frac{Q \cdot 231 \cdot \eta_v}{V_g} \quad \text{min}^{-1}(\text{rpm})$$

$$\text{Output torque } M = \frac{V_g \cdot \Delta p \cdot \eta_m}{2 \cdot \pi} \quad (\text{lbf}\cdot\text{in})$$

$$\text{Output power } P = \frac{Q \cdot \Delta p \cdot \eta_t}{1714} \quad (\text{hp})$$

**Where:**

SI units [US units]

$V_g$	= Displacement per revolution	$\text{cm}^3/\text{rev}$ [ $\text{in}^3/\text{rev}$ ]
$p_o$	= Outlet pressure	bar [psi]
$p_i$	= Inlet pressure	bar [psi]
$\Delta p$	= $p_o - p_i$ (system pressure)	bar [psi]
$n$	= Speed	$\text{min}^{-1}$ (rpm)
$\eta_v$	= Volumetric efficiency	
$\eta_m$	= Mechanical efficiency	
$\eta_t$	= Overall efficiency ( $\eta_v \cdot \eta_m$ )	

## System Design Parameters

### Name Plate

L and K Frame motors are identified by a name plate affixed to the motor housing. The nameplate contains the model number, model code, serial number, and country of manufacture.

#### **Serial number**

Every unit is identified by a unique serial number. The serial number gives manufacturing location, year and week built, and a unique sequence number. The serial number in the example to the left is decoded as:

A Ames, Iowa, USA

11 Year 2011

13 Week 13

67890 Sequence number

#### **Model number**

A Danfoss model number is issued for every unique configuration. Use this number when placing orders.

#### **Model code**

The model code completely defines the options for a specific unit. See [Model Code](#) on page 17, for available options and codes.

*Name plate*



P101866E



## Technical Information L and K Frame Variable Motors

### Product Coding

#### Model Code

A B C1 2 D E1 2 3 F G H J K 1 2 L M N  
 □□ □□□ □ □□□ □□□ □ □ N □ □□ □□ □□□ □□□ □□□

#### A Frame

Code	Description
L	Frame size: displacements 25, 30, and 35 cm <sup>3</sup> [1.50, 1.83, and 2.14 in <sup>3</sup> ]
K	Frame size: displacements 38 and 45 cm <sup>3</sup> [2.32 and 2.75 in <sup>3</sup> ]

#### B Mount

Code	Description
V	SAE-B
C	Cartridge

#### C1 Displacement

Code	Displacement
25C	25 cm <sup>3</sup> /rev [1.50 in <sup>3</sup> /rev]
30D	30 cm <sup>3</sup> /rev [1.83 in <sup>3</sup> /rev]
35E	35 cm <sup>3</sup> /rev [2.14 in <sup>3</sup> /rev]
38C	38 cm <sup>3</sup> /rev [2.32 in <sup>3</sup> /rev]
45D	45 cm <sup>3</sup> /rev [2.75 in <sup>3</sup> /rev]

#### C2 Speed sensing ring

Code	Description
N	None
S	Speed ring installed, L Frame = 41 pulses per revolution, K Frame = 44 pulses per revolution

#### D Output shaft

Code	Description
A	13 tooth 16/32 pitch per ANSI B92.1-1970 class 5
C	0.875 in straight key (LV/KV only)
D	1:8 taper (LV/KV only)
E	15 tooth 16/32 pitch per ANSI B92.1-1970 class 5
F	1:8 taper/ with dust seal
H	15 tooth 16/32 pitch per ANSI B92.1-1970 class 5 (LC/KC only) (with 26 mm spline)

#### E1 Endcap porting

Code	Description
A	Twin radial, 1 1/16 in-12 O-ring boss w/Axial control Port (LC/KC only) (not available with loop flushing)
C	Twin radial, 1 1/16 in-12 O-ring boss with Anti-Cavitation and Shock Valve
H	Twin radial, 1 1/16 in-12 O-ring boss with Axial HIC mounting face (LV/KV only)
R	Twin radial, 1 1/8 in-12 O-ring boss
Y	Axial, 1 1/8 in-12 O-ring boss (LV/KV only)

Reference [Loop Flushing](#) on page 24 and [Technical Specifications](#) on page 8.

**Product Coding**

A B    C 1 2    D E 1 2 3    F    G    H    J K 1 2    L    M    N  
 □□   □□□□   □   □□□   □□□   □   □   □   □□□   □□□□   □□□□   □□□□   □□□□

**E2 Loop flushing**

Code	Description
A	Flow = option A, crack pressure 6.9 bar [100 psi] (LV/KV only)
B	Flow = option B, crack pressure 6.9 bar [100 psi] (LV/KV only)
C	Flow = option C, crack pressure 6.9 bar [100 psi] (LV/KV only)
D	Anti-Cavitation, Port A, 345 Bar Shock Valve
E	Anti-Cavitation, Port A, 345 Bar Shock Valve
F	Anti-Cavitation, Port A, 280 Bar Shock Valve
G	Anti-Cavitation, Port A, 280 Bar Shock Valve
N	None (standard), crack pressure 10.3 bar [150 psi]
1	Flow = option 1, crack pressure 10.3 bar [150 psi]
2	Flow = option 2, crack pressure 10.3 bar [150 psi]
3	Flow = option 3, crack pressure 10.3 bar [150 psi]
4	Flow = option 4, crack pressure 10.3 bar [150 psi]

**E3 Minimum angle adjustment option**

Code	Description
F	Non-adjustable fixed stop

**F Minimum angle/displacement setting**

Code	Angle	% of max.	L25C	L30D	L35E	K38C	K45D
F00	0°	0	0	0	0	0	0
F01	1°	5.3%	1.34 cm <sup>3</sup>	1.61 cm <sup>3</sup>	1.88 cm <sup>3</sup>	2.04 cm <sup>3</sup>	2.42 cm <sup>3</sup>
F07	7°	37.8%	9.45 cm <sup>3</sup>	11.34 cm <sup>3</sup>	13.23 cm <sup>3</sup>	14.36 cm <sup>3</sup>	17.00 cm <sup>3</sup>
F08	8°	43.2%	10.81 cm <sup>3</sup>	12.97 cm <sup>3</sup>	15.13 cm <sup>3</sup>	16.44 cm <sup>3</sup>	19.46 cm <sup>3</sup>
F09	9°	48.7%	12.19 cm <sup>3</sup>	14.63 cm <sup>3</sup>	17.07 cm <sup>3</sup>	18.52 cm <sup>3</sup>	21.94 cm <sup>3</sup>
F10	10°	54.3%	13.57 cm <sup>3</sup>	16.28 cm <sup>3</sup>	18.99 cm <sup>3</sup>	20.62 cm <sup>3</sup>	24.42 cm <sup>3</sup>
F11	11°	59.8%	14.96 cm <sup>3</sup>	17.94 cm <sup>3</sup>	21 cm <sup>3</sup>	22.73 cm <sup>3</sup>	26.92 cm <sup>3</sup>
F12	12°	65.1%	16.29 cm <sup>3</sup>	19.55 cm <sup>3</sup>	22.88 cm <sup>3</sup>	24.77 cm <sup>3</sup>	29.34 cm <sup>3</sup>
F13	13°	70.2%	17.62 cm <sup>3</sup>	21.16 cm <sup>3</sup>	24.76 cm <sup>3</sup>	26.81 cm <sup>3</sup>	31.76 cm <sup>3</sup>

**G Control type**

Code	Description
S	Single input hydraulic control
T	Dual input hydraulic control (LV/KV only) (must use X drain orifice)

**H Supply orifice**

Code	Description
N	None (standard)

**J Drain orifice**

Code	Description
N	None (standard)
X	Plugged: Required for dual line hydraulic control (use when code G=T) (LV/KV only)

**Product Coding**

A B    C1 2    D E 1 2 3    F    G    H    J K 1 2    L    M    N  
 □□   □□□□   □   □□□   □□□   □   N   □   □□   □□□   □□□□   □□□□

**K1 Speed sensor/connector**

Code	Description
A	None: Housing not machined for speed sensing (use when code C2=N)
B	None: Housing machined for speed sensor. Port plugged.
C	Speed sensor: 4.5–8.5 V, 4 wire directional, Weather-Pack connector, 200 mm [8 in] lead. KPPG 13408 (internal speed ring required: code C2=5).

**K2 Maximum angle adjustment option**

Code	Description
F	Non-adjustable fixed stop

**L Maximum angle/displacement setting**

Code	Angle	% of max.	L25C	L30D	L35E	K38C	K45D
F18	18°	100%	25 cm <sup>3</sup>	30 cm <sup>3</sup>	35 cm <sup>3</sup>	38 cm <sup>3</sup>	45 cm <sup>3</sup>
F17	17°	94.1%	23.52 cm <sup>3</sup>	28.22 cm <sup>3</sup>	32.92 cm <sup>3</sup>	35.76 cm <sup>3</sup>	42.34 cm <sup>3</sup>
F16	16°	88.2%	22.06 cm <sup>3</sup>	26.47 cm <sup>3</sup>	30.88 cm <sup>3</sup>	33.54 cm <sup>3</sup>	39.71 cm <sup>3</sup>
F15	15°	82.5%	20.62 cm <sup>3</sup>	24.74 cm <sup>3</sup>	—	31.34 cm <sup>3</sup>	37.11 cm <sup>3</sup>

**M Special hardware**

Code	Description
NNN	None (standard)

**N Special features**

Code	Description
NNN	None (standard)

Additional minimum displacements are available, contact your Danfoss representative for more information

**Features and Options**
**Speed Sensor**

K and L Frame motors are available with an optional speed sensor. This hall-effect pick-up senses motor speed and direction of rotation via a magnetic ring mounted to the cylinder block. The sensor is available with a 4-pin Packard Weather-Pack connector. For more information, refer to *KPP Pulse Pick-up Technical Information, 11029257*.

*KPP Pulse Pick-up with Weather-Pack connector (KPPG13408 PPU shown)*

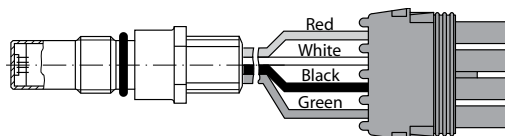

Packard Weather-Pack  
4 pin  
(supplied connector)

mating connector  
No.: K03379

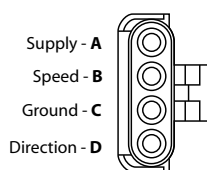

P104 167E

**Specifications**

Supply voltage	4.5 to 8.5 Vdc (regulated)
Output voltage (high)	Supply minus 0.5 Vdc, minimum (no load)
Output voltage (low)	0.5 Vdc Maximum (no load)
Maximum frequency	15 kHz
Max. operating current	20 mA at 1 kHz
Load	15 kΩ to both ground and supply
Peak reverse voltage	-15 Vdc continuous
Peak transient voltage	80 Vdc for 2 ms (max.)
Pulses per rev.	41 (LV/LC motor) 44 (KV/KC motor)

**Shaft Torque**

L and K Frame variable motors are available with splined, tapered, and straight-keyed shafts.

**Shaft torque and spline lubrication**

The rated torque is a measure of tooth wear and is the level at which a normal spline life of  $2 \times 10^9$  shaft revolutions can be expected. The rated torque presumes a regularly maintained minimum level of lubrication via a moly-disulfide grease in order to reduce the coefficient of friction and to restrict the presence of oxygen at the spline interface. It is also assumed that the mating spline has a minimum hardness of Rc 55 and full spline depth. The rated torque is proportional to the minimum active spline length.

Maximum torque ratings are based on torsional fatigue strength considering 100,000 full load reversing cycles. However, a spline running in oil-flooded environment provides superior oxygen restriction in addition to contaminant flushing. The rated torque of a flooded spline can increase to that of the maximum published rating. A flooded spline would be indicative of a pump driven by a pump drive or plugged into an auxiliary pad of a pump.

Maintaining a spline engagement at least equal to the Pitch Diameter will also maximize spline life. Spline engagements of less than  $\frac{3}{4}$  Pitch Diameter are subject to high contact stress and spline fretting.

**Features and Options**
**Shaft torque for tapered shafts**

The rated torque is based on the contact pressure between the shaft and hub surfaces with poor surface contact areas. With an increased quality of the contact areas, the contact pressure between the shaft and hub is increased and allows higher torque to be transmitted.

When a key is used for orientation of the hub on the shaft in conjunction with poor quality contact surfaces, the transmitted torque will drop significantly. This is due to the key carrying the torque, which limits the shaft torque carrying capability.

Maximum torque rating is based on an ideal contact area of 100 % and the retaining nut properly torqued. This allows for the highest contact pressure between the shaft and the hub.

Complete a detailed bolted joint analysis to ensure proper contact pressure, load and torque retention characteristics are achieved.

Shaft taper: 1:8 per SAE J501

Maximum retaining nut tightening torque: 250 lb·ft (340 Nm)

Any torque in excess of this may lead to shaft damage.

This maximum torque is based on using an SAE J429 Grade 8 standard, non-self-locking nut with a clean/oiled interface.

**Output Shafts**

L and K Frame variable motors are available with splined, tapered, and straight-keyed shafts. See the following page for details.

**Lubrication of splined shafts**

Splined shaft couplings require lubrication to minimize corrosion, fretting, and premature wear. Flooded or splashed oil lubrication is ideal. In applications where this is not possible, Danfoss recommends you apply a compound of 50% high temperature grease and 50% molybdenum disulfide powder to the splines during installation and at regular intervals during service life. This lubricant is not soluble in oil.

*Shaft options*

Code	Description	Availability		Torque rating		Drawing
		LV/KV	LC/KC	Continuous N·m [lbf·in]	Maximum N·m [lbf·in]	
A	13 tooth spline 16/32 pitch ANSI B92.1 1970-Class 5	X	—	73 [650]	226 [2000]	

**Features and Options**
*Shaft options (continued)*

Code	Description	Availability		Torque rating		Drawing
		LV/KV	LC/KC	Continuous N·m [lbf·in]	Maximum N·m [lbf·in]	
A	13 tooth spline 16/32 pitch ANSI B92.1 1970-Class 5	—	X	73 [650]	226 [2000]	
C	Ø 22.225 mm [0.875 in] Straight keyed (does not ship with key)	X	—	N/A	362 [3200]	
D	Ø 22.225 mm [0.875 in] 1:8 Taper (does not ship with key) Refer to Shaft Torque For Tapered Shafts pg 17 for information regarding retaining nut torque.	X	—	N/A	362 [3200]	

**Features and Options**
*Shaft options (continued)*

Code	Description	Availability		Torque rating		Drawing
		LV/KV	LC/KC	Continuous N·m [lbf·in]	Maximum N·m [lbf·in]	
E	15 tooth spline 16/32 pitch ANSI B92.1 1970-Class 5	X	—	153 [1350] (Continuous torque rating based on spline tooth wear)	362 [3200]	
E	15 tooth spline 16/32 pitch ANSI B92.1 1970-Class 5	—	X	153 [1350] (Continuous torque rating based on spline tooth wear)	362 [3200]	
F	Ø 22.225 mm [0.875 in] 1:8 Taper with Dust Seal Option (does not ship with key) Refer to Shaft Torque For Tapered Shafts pg 17 for information regarding retaining nut torque.	X	X	N/A	362 [3200]	

**Features and Options**
*Shaft options (continued)*

Code	Description	Availability		Torque rating		Drawing
		LV/KV	LC/KC	Continuous N·m [lbf·in]	Maximum N·m [lbf·in]	
F	Ø 22.225 mm [0.875 in] 1:8 Taper with Dust Seal Option (does not ship with key) Refer to Shaft Torque For Tapered Shafts pg 17 for information regarding retaining nut torque.	X	X	N/A	362 [3200]	

**Loop Flushing**

K and L motors incorporate an optional integral loop flushing valve. Use the loop flushing valve in circuits requiring the removal of excessive contamination or installations that require the removal of additional fluid from the main hydraulic circuit due to cooling requirements.

K and L motors equipped with an integral loop flushing shuttle valve also include a loop flushing relief valve. The loop flushing relief valve poppet includes an orifice which controls flushing flow. Flushing flow of 5 to 8 L/min (1.5 - 2 gpm) is typical.

The opening pressure (indicated in graph below) of the loop flushing relief valve should be equal to or less than the charge pressure setting of the pump. Contact your Danfoss representative for assistance.

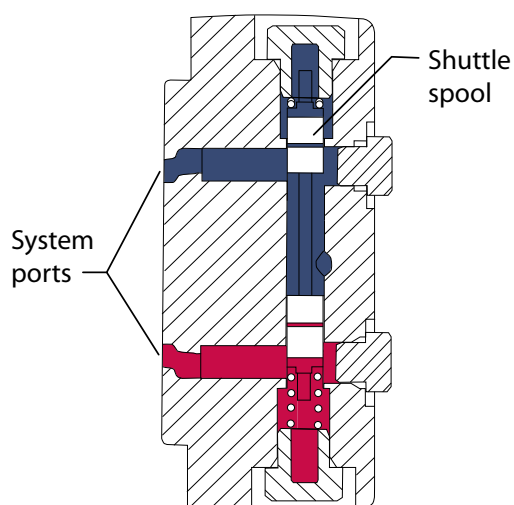
*Loop Flushing valve*

P106 493E



**Features and Options**

Relief valve

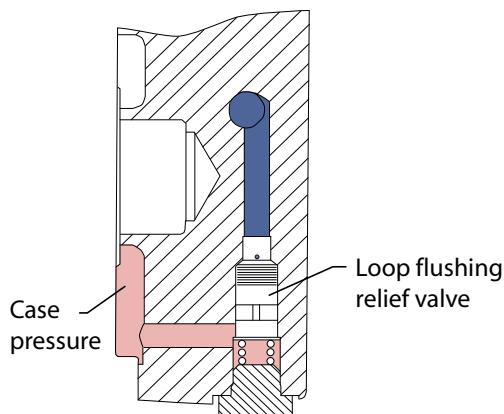

P106 494E

Loop flushing should not be used when using L/K motors in an open circuit configuration. Low loop/charge pressures will not be high enough to open the loop flushing relief valve.

Loop Flushing flow

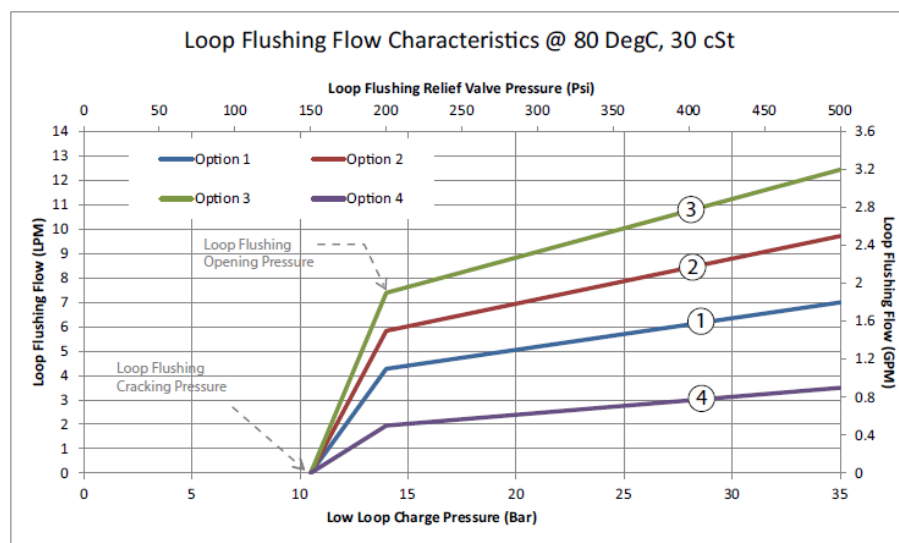

**Anti-Cavitation Valve Option**

L&K motors are available with an anti-cavitation valve option. The key application for this option is open circuit fan drives.

The anti cavitation valve combines the function of a shock valve and check valve within the same cavity which is integrated into the endcap. The check valve function provides protection against cavitation which can occur upon introduction of an overrunning load or due to loss of input flow. In such case, the system delta pressure becomes negative and the check valve opens connecting the motor inlet and outlet, effectively short-circuiting the motor. The shock valve function is intended to be used for system over-pressure protection events of limited duration only. It is not intended for continuous system pressure limitation.

The shock valve is available with 280 bar or 345 bar setting.

For this option the high pressure port needs to be defined upfront to get the correct motor rotation. Reversing the motor is not possible with this option.

**Features and Options**

*Anti-Cavitation Valve, Port A High Pressure*

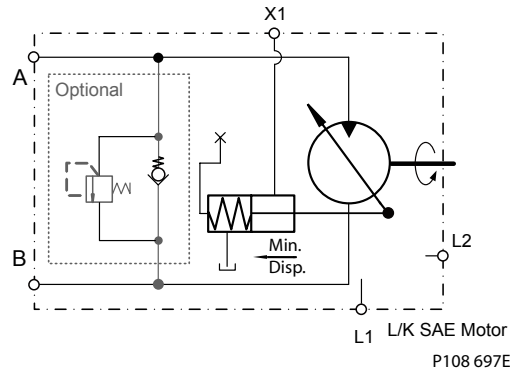

*Anti-Cavitation Valve, Port B High Pressure*

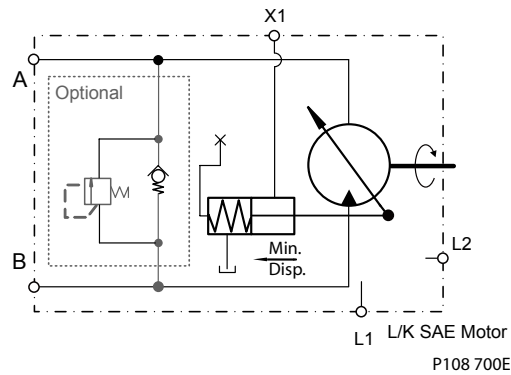

**Dust Seal Option**

The dust seal option has been designed to increase the resistance to airborne particulates which could contaminate and potentially damage the motor output shaft seal. The speed rating of the dust seal is the same as the motor speed rating.

Available only with the tapered shaft option F.

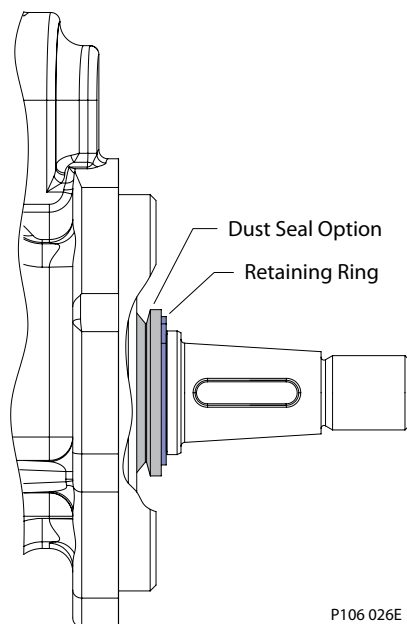
**Features and Options**

**Displacement Limiters**

L and K Frame variable motors can be equipped with optional fixed (non-adjustable) displacement limiters. Refer to Maximum Angle/Displacement Setting in *Model Code* on page 17, for available displacement settings.

**Motor Rotation**

L and K Frame variable motors are fully bidirectional. The chart to the right gives the direction of rotation with respect to flow direction through the motor.

*Rotation by flow direction*

Mount	SAE-B	Cartridge
Flow A→B	CCW	CW
Flow B→A	CW	CCW

**Controls**

L and K Frame variable motors are designed to operate in two positions: maximum and minimum displacement. The motors are spring biased to maximum displacement and hydraulically shifted to minimum displacement. SAE-B mount motors can operate with a single or dual line control. Cartridge mount motors operate with a single line control only. Pressure applied at port X1 shifts the motor to minimum displacement. Pressure at X2 (dual line control) can assist the shift to maximum displacement. Refer to the table above for control input pressure range.

**Control orificing**

Cartridge and SAE mount motor controls rely on external valving and orificing to regulate shift speeds. You can achieve quick acceleration (shift to min) and slow deceleration (shift to max) simply by installing an orifice in the tank line of the external control valve.

SAE-B mount motors with single line controls can have optional, internal, supply and drain orifices installed to regulate control response times. Contact your Danfoss representative for available orifice sizes.

## Features and Options

### **Brake Release Port (cartridge motors)**

Cartridge mount motors are equipped with a brake release port to allow access to the brake-release feature of the gear box from the rear of the motor. This consists of a simple passage through the motor housing with a rear-facing 7/16 in. SAE O-ring boss port. To locate the port on the gear box, refer to [Installation Drawings](#) on page 29. Applications using this brake release port require an O-ring to seal the passage against the gear box.

While all motors will have the brake release port, not all gearboxes are compatible with this motor feature. The rated pressure for the brake release port on the motor housing is 250 bar (this does take into account the O-ring interface between the motor and gearbox). Consult your gearbox manufacturer for suitability and compatibility. If your gearbox is not compatible with this feature, simply leave the port plugged.

**Installation Drawings**

**SAE-B Mount (LV/KV)**

*Axial ports with loop flushing*

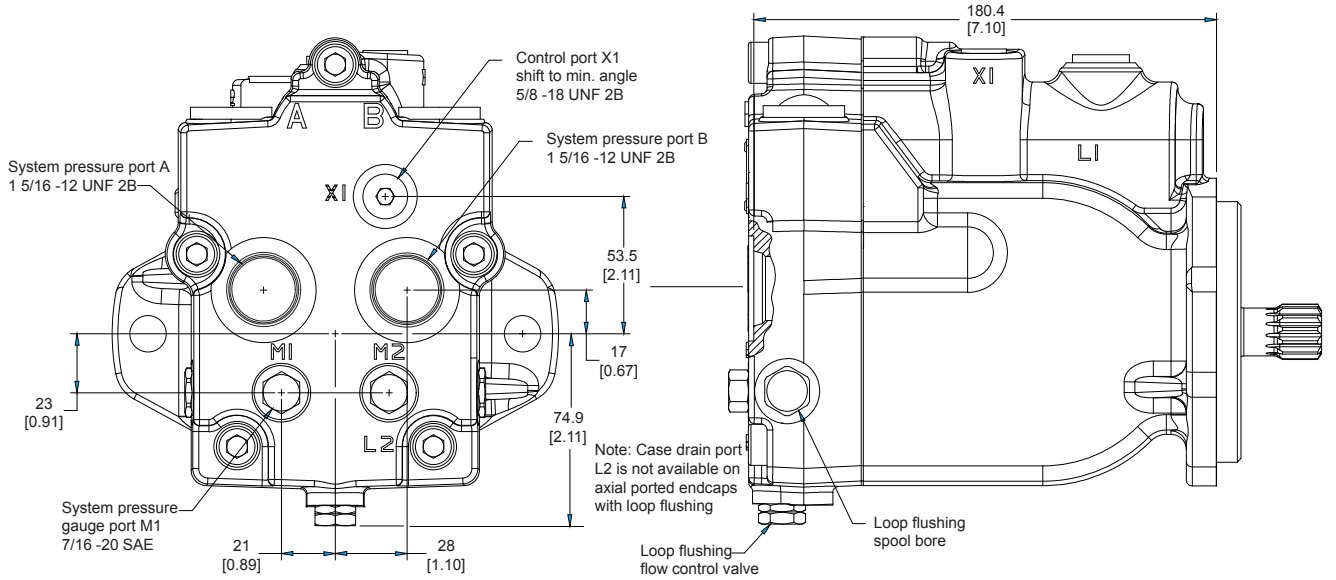

**Axial ports without loop flushing**

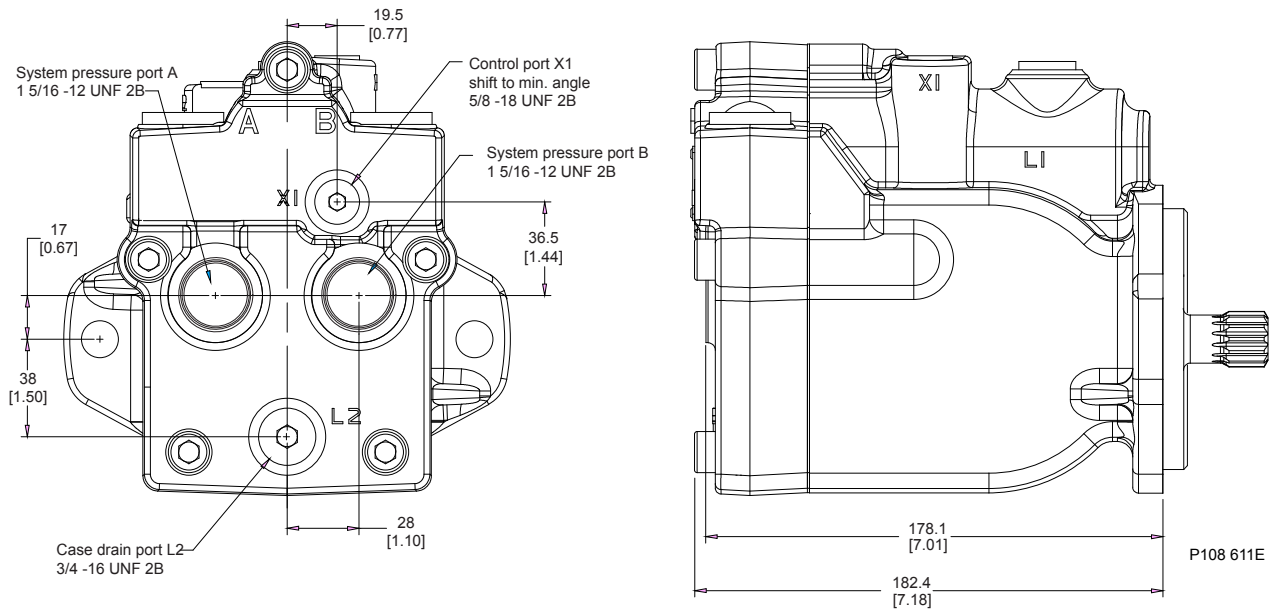

**Installation Drawings**

*Radial ports without loop flushing*

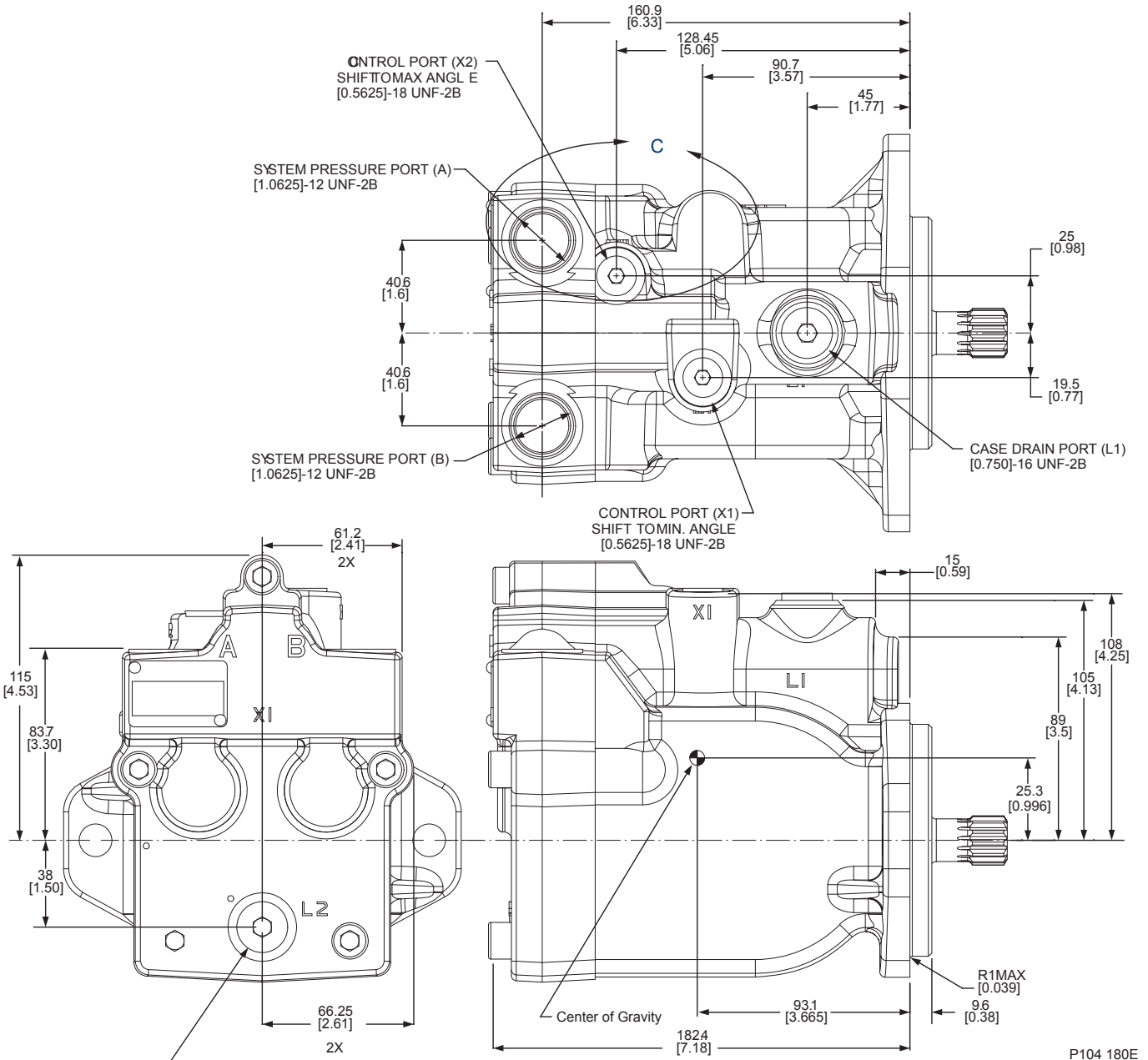

P104 180E

**VIEWC**  
Motor with speed sensor

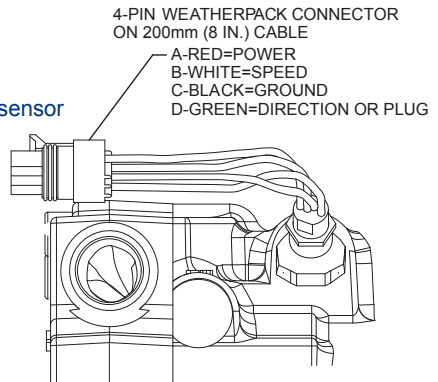

Installation Drawings

Radial ports with loop flushing

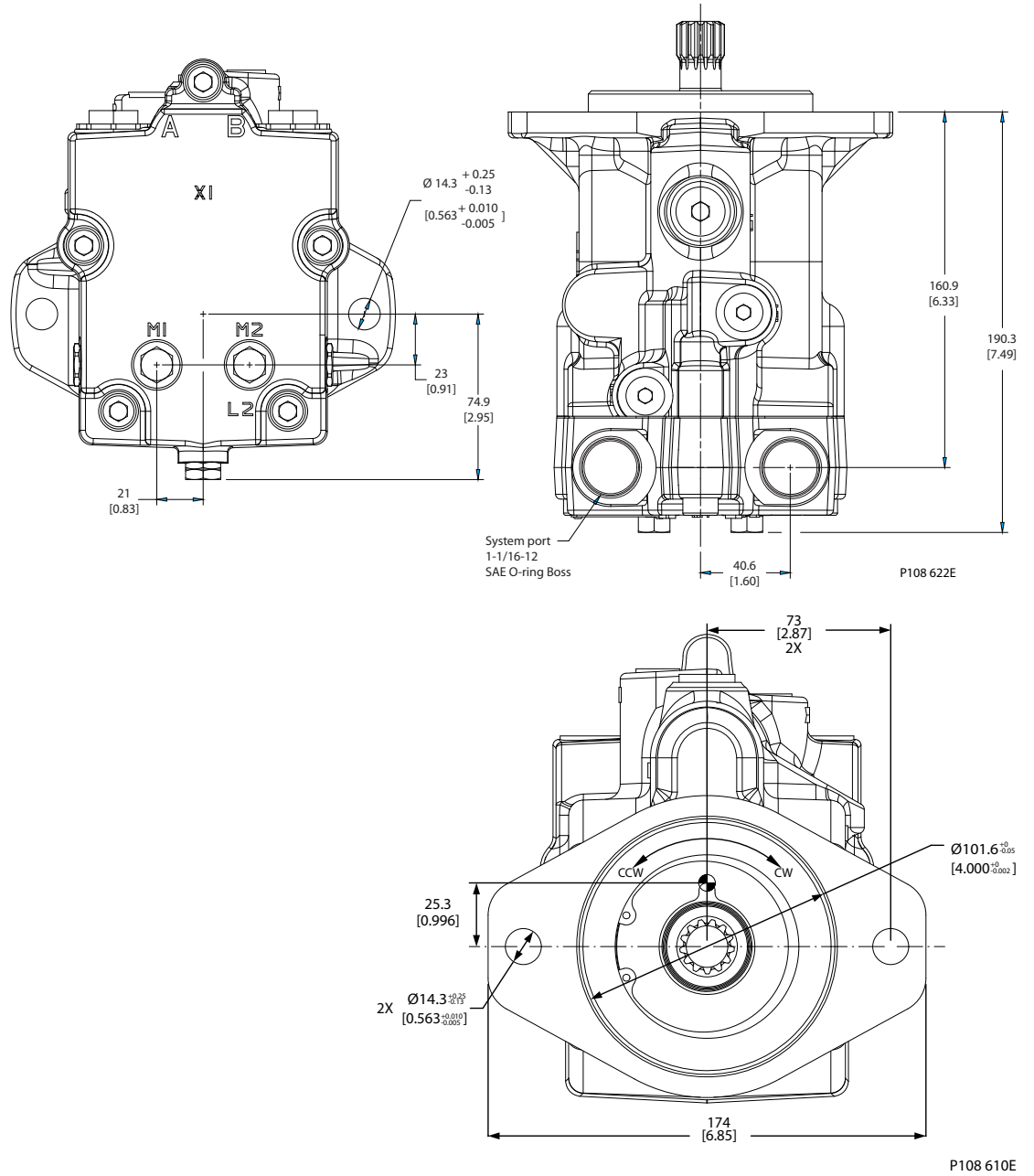

Recommended mounting hardware

Bolt size	Grade	Torque N·m [lbf·ft]
1/2 inch	5	86 [64]
	8	122 [90]

Use hardened washer under each bolt head.

Installation Drawings

Radial ports with Anti-cavitation valve

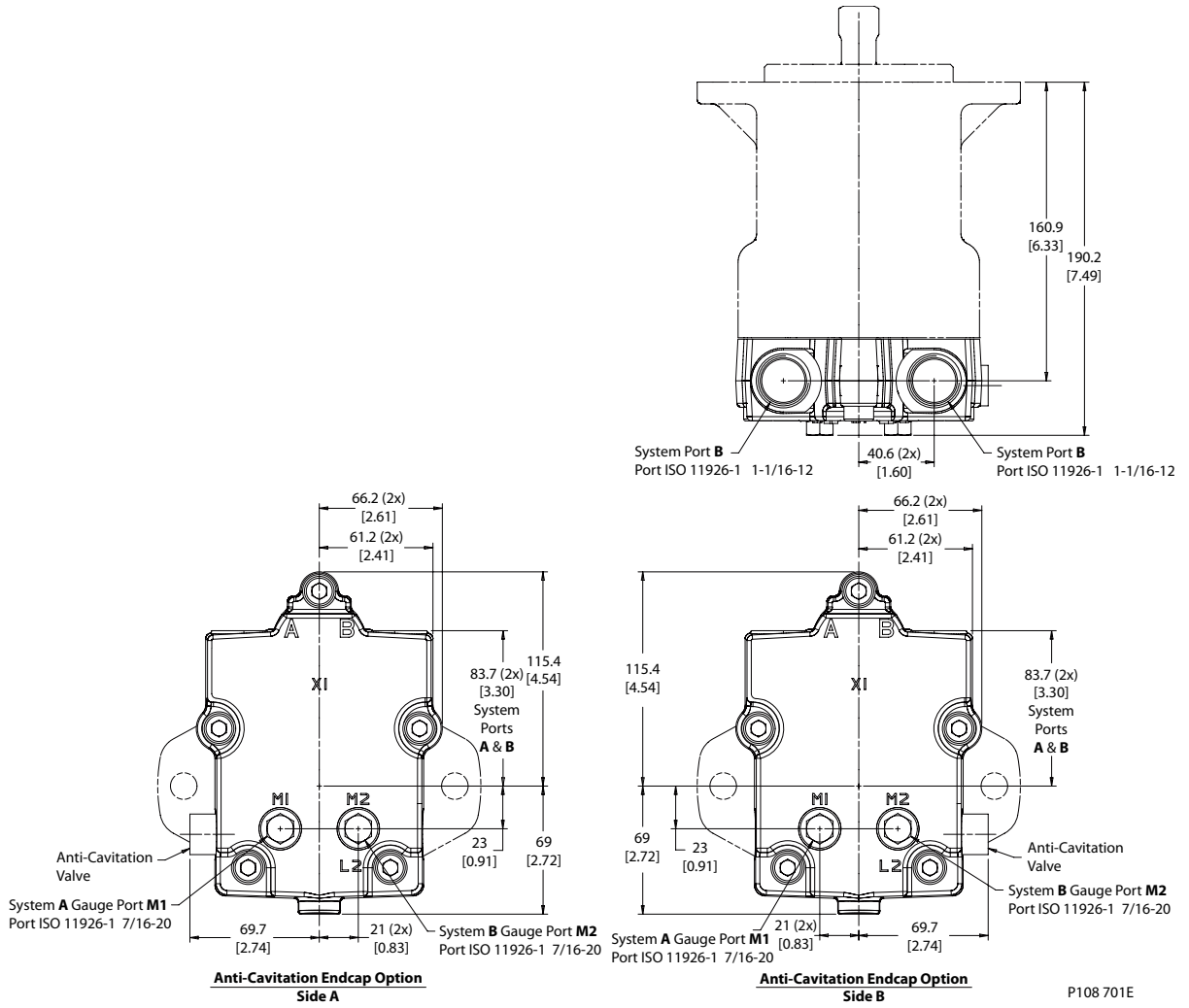

P108 701E



Installation Drawings

HIC options

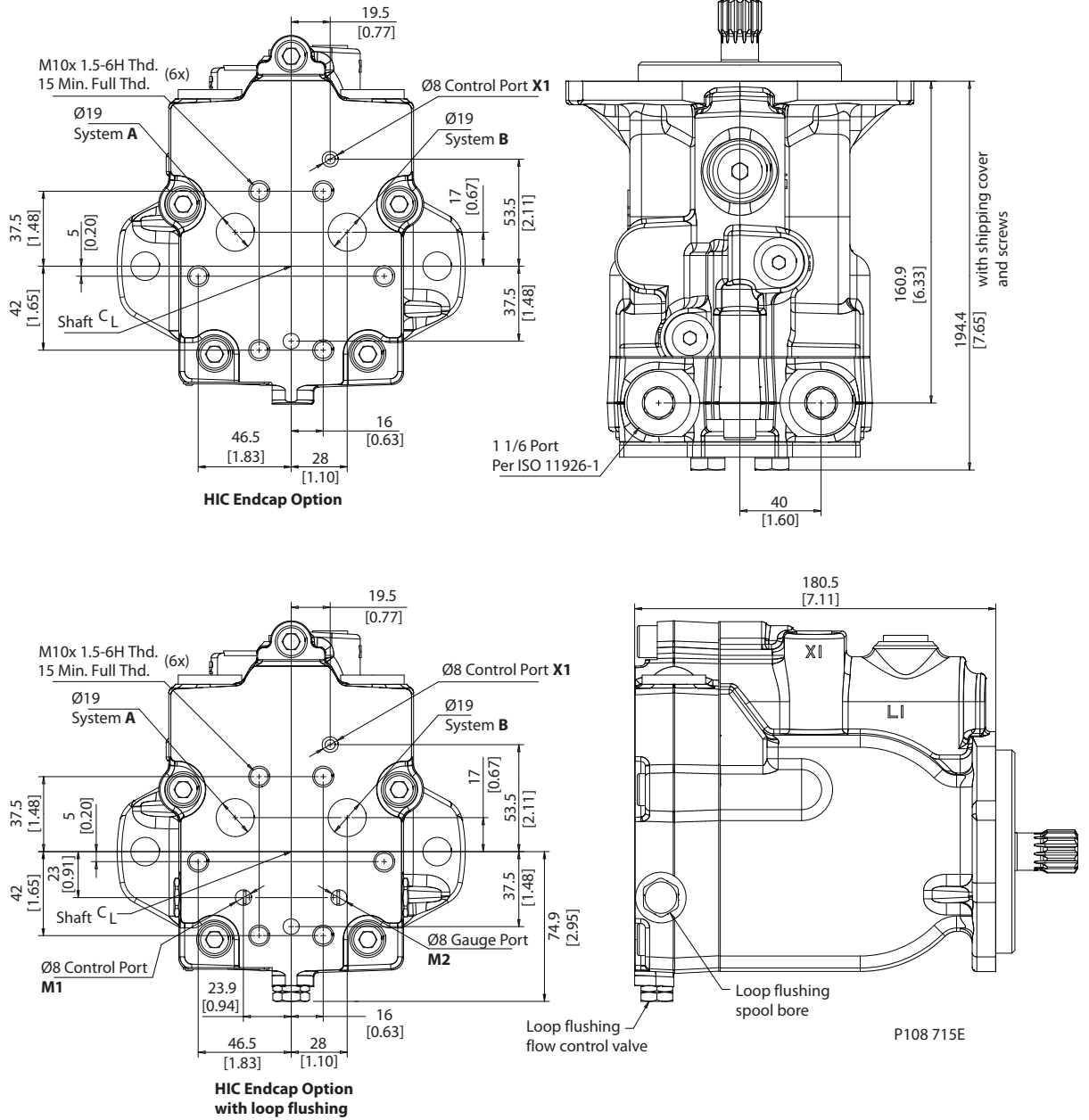

Installation Drawings

Cartridge (LC/KC)

Radial ports without loop flushing

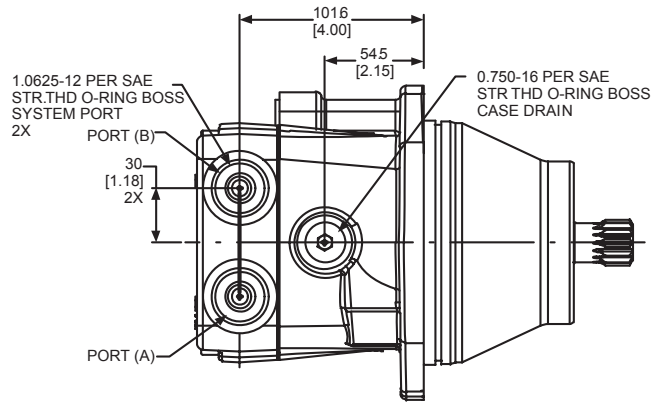
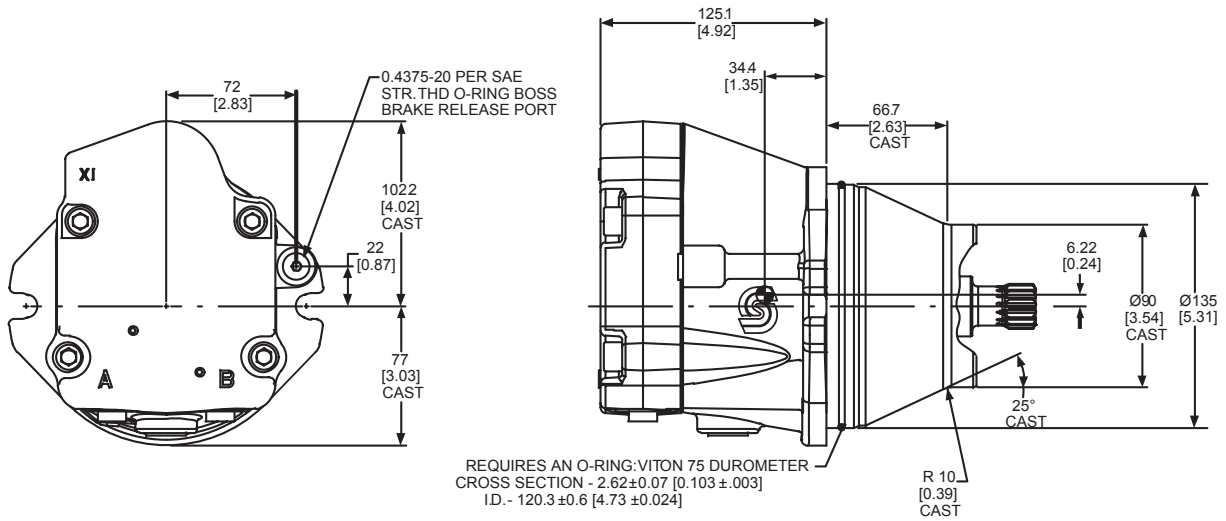

Radial Ports with loop flushing

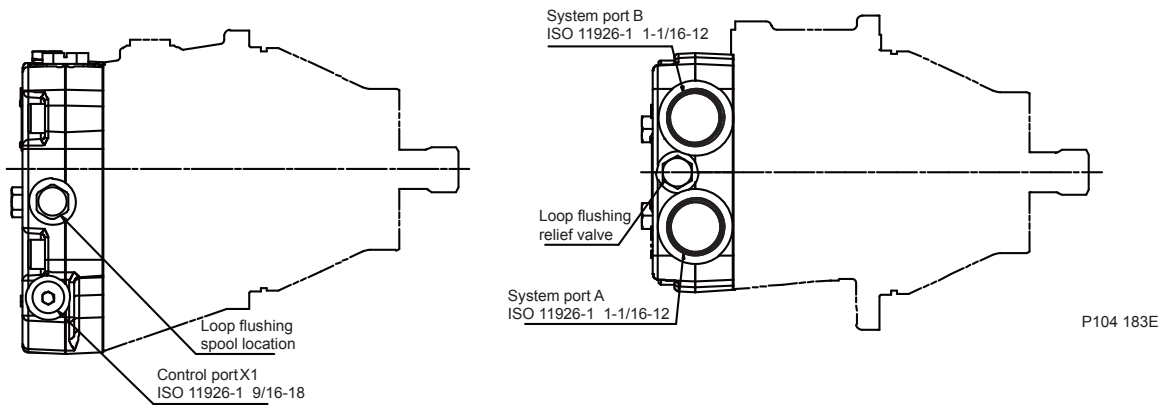

**Installation Drawings**

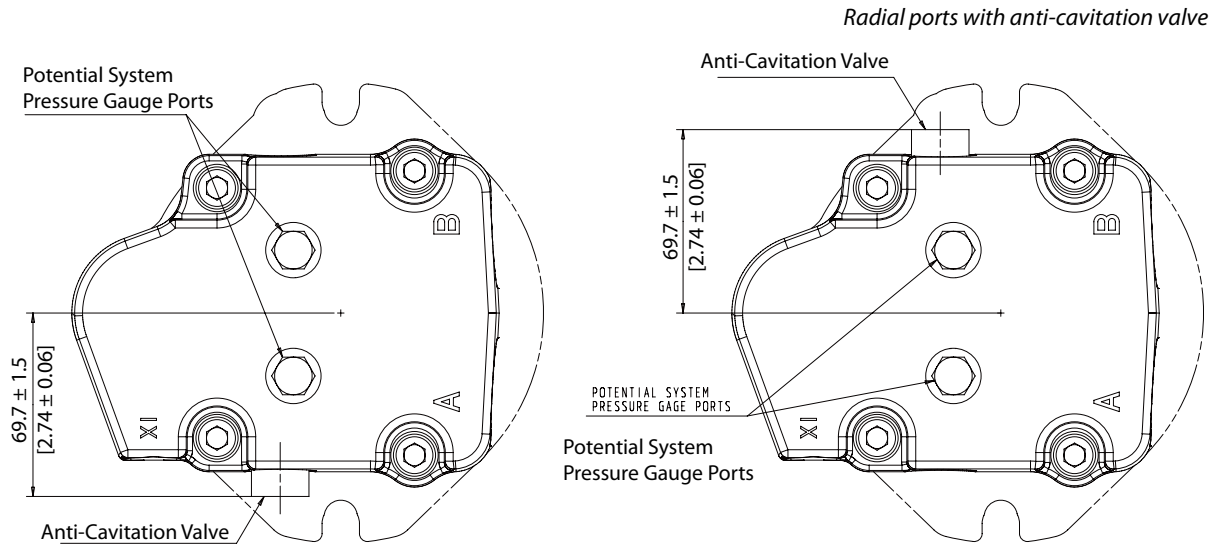

P108 716E

*Mounting flange dimensions*

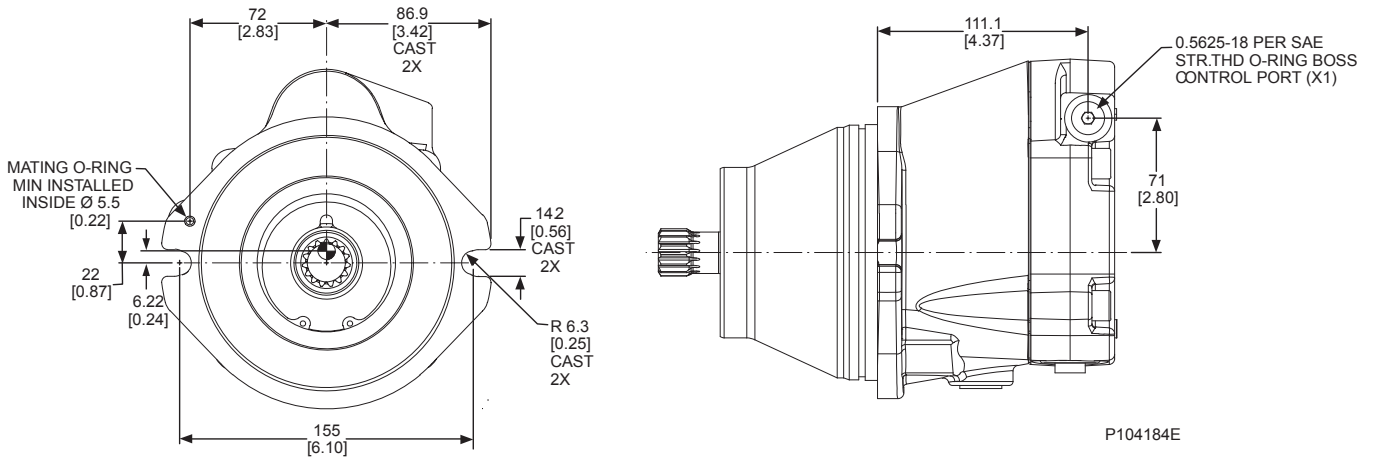

P104184E

*Recommended mounting hardware*

Bolt size	Grade	Torque N•m [lbf•ft]	Mounting circle diameter
1/2 in.	5	86 [64]	160 mm [6.299 in]
	8	122 [90]	

Use hardened washer under each bolt head.





**Products we offer:**

- Bent Axis Motors
- Closed Circuit Axial Piston Pumps and Motors
- Displays
- Electrohydraulic Power Steering
- Electrohydraulics
- Hydraulic Power Steering
- Integrated Systems
- Joysticks and Control Handles
- Microcontrollers and Software
- Open Circuit Axial Piston Pumps
- Orbital Motors
- PLUS+1® GUIDE
- Proportional Valves
- Sensors
- Steering
- Transit Mixer Drives

**Danfoss Power Solutions** is a global manufacturer and supplier of high-quality hydraulic and electronic components. We specialize in providing state-of-the-art technology and solutions that excel in the harsh operating conditions of the mobile off-highway market. Building on our extensive applications expertise, we work closely with our customers to ensure exceptional performance for a broad range of off-highway vehicles.

We help OEMs around the world speed up system development, reduce costs and bring vehicles to market faster.

Danfoss – Your Strongest Partner in Mobile Hydraulics.

**Go to [www.powersolutions.danfoss.com](http://www.powersolutions.danfoss.com) for further product information.**

Wherever off-highway vehicles are at work, so is Danfoss.

We offer expert worldwide support for our customers, ensuring the best possible solutions for outstanding performance. And with an extensive network of Global Service Partners, we also provide comprehensive global service for all of our components.

Please contact the Danfoss Power Solution representative nearest you.

**Comatrol**

[www.comatrol.com](http://www.comatrol.com)

**Schwarz Müller-Inverter**

[www.schwarzmueller-inverter.com](http://www.schwarzmueller-inverter.com)

**Turolla**

[www.turollaocg.com](http://www.turollaocg.com)

**Valmova**

[www.valmova.com](http://www.valmova.com)

**Hydro-Gear**

[www.hydro-gear.com](http://www.hydro-gear.com)

**Daikin-Sauer-Danfoss**

[www.daikin-sauer-danfoss.com](http://www.daikin-sauer-danfoss.com)

Local address:

**Danfoss Power Solutions US Company**  
2800 East 13th Street  
Ames, IA 50010, USA  
Phone: +1 515 239 6000

**Danfoss Power Solutions GmbH & Co. OHG**  
Krokamp 35  
D-24539 Neumünster, Germany  
Phone: +49 4321 871 0

**Danfoss Power Solutions ApS**  
Nordborgvej 81  
DK-6430 Nordborg, Denmark  
Phone: +45 7488 2222

**Danfoss Power Solutions (Shanghai) Co. Ltd.**  
Building #22, No. 1000 Jin Hai Rd  
Jin Qiao, Pudong New District  
Shanghai, China 201206  
Phone: +86 21 3418 5200

Danfoss can accept no responsibility for possible errors in catalogues, brochures and other printed material. Danfoss reserves the right to alter its products without notice. This also applies to products already on order provided that such alterations can be made without subsequential changes being necessary in specifications already agreed. All trademarks in this material are property of the respective companies. Danfoss and the Danfoss logotype are trademarks of Danfoss A/S. All rights reserved.