

DEUBLIN®

Engineered for Performance



ROTATING UNIONS

water steam air hydraulic hot oil vacuum coolant custom applications



Our aim: "To make every effort toward producing the best product of its kind on the Market".

This tenet serves as an incentive and an obligation in equal measure. Adherence to this policy has been responsible for our growth from a small garage shop to the world's largest manufacturer of Rotating Unions with a world-wide sales and service network.

Wherever water, steam, oil, coolant lubricants or other media have to be conveyed into or through turning machine parts, like rollers, shafts or spindles, rotating unions are employed in a wide range of industrial fields.

Developed in 1945, and continually improved as a result of practical requirements, **DEUBLIN** Rotating Unions are at the cutting edge of technology today.

DEUBLIN Rotating Unions - the industry standard. Our customers can rely on our engineering expertise, R&D capabilities, manufacturing techniques and more than 60 years of knowledge and experience.

Our product range is constantly being developed and expanded. In addition, we offer special solutions, customer specified variations and modular designs which enable us to provide users with the perfect solution for virtually any application.

Direct contact with customers and a close collaboration with the original equipment manufacturers provide the basis for continuous improvement.

Quality encompasses our entire enterprise. At **DEUBLIN**, reliable products at competitive prices and just-on-time deliveries are standards.

This, of course, requires an integrated total quality control system that is practiced in all areas of our organisation.

Quality is the result of teamwork!



DEUBLIN has its Corporate Headquarter in Waukegan, USA. For over 30 years the facilities in Germany and Italy have been producing for the European, African and Near Eastern Market.

Besides sales and warehouse facilities in almost every country in Europe, we also have company owned subsidiaries in Brazil, China, Germany, Finland, France, Italy, Japan, Mexico, Austria, Poland, Singapore, Spain, South Korea and the United Kingdom.

Our customers can rely on our worldwide manufacturing and sales & service network.

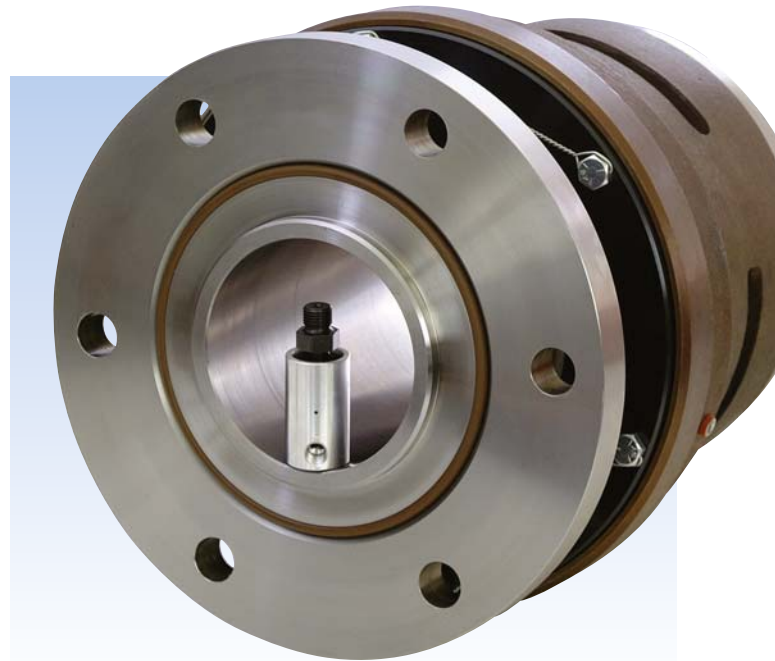

Due to its Total Quality Management System **DEUBLIN** was awarded its initial Certification pursuant to DIN EN ISO 9001 in 1996 by the German Standard Institute. In October 2002 the re-certification followed accompanied by the initial Certification for its Environmental Management System pursuant to DIN EN ISO 14001.

Certified as an **Authorised Economic Operator (AEO)** since **March 2009**, **DEUBLIN** has established that its supply chain is secure and customs-reliable. For its customers, it means faster flow of goods and materials. This is a significant advantage for **DEUBLIN's** partners worldwide.

DEUBLIN sets new standards.



Please unfold for DEUBLIN Selection Chart

Selection Chart for *DEUBLIN* Rotating Unions

Commodity
Tariff No. (HS):
84 87 90 90

Size	Series	Max. Operating Data			Special Features	Pages
		P bar	T °C	n min ⁻¹		
for Water & Hot Oil up to 120°C						6 - 23
DN 10 - 50	57	10	90	3,500	bearings lubricated for life	6 - 12
DN 10 - 50	55	50	120	3,500	general purpose, standard	7 - 12
DN 65	755	14	120	750	general purpose, standard	13
DN 40, 50 & 65	555, 655, 755	50	120	1,500	general purpose with flange rotor	14 - 15
DN 80	57 only water	10	120	500	standard with thread or flange rotor	16 - 17
DN 50 - 100	6000	10	120	750	with repair cartridge	18 - 21
DN 125	F	16	120	1,000	for water	22
DN 10 - 40	54	120	71	3,500	stainless steel	23
for Steam & Hot Oil up to 230°C						24 - 32
DN 10 & 15	N Sat. Steam	17	200	750	carbon graphite bearing and spherical seal	24
DN 10 & 15	N Hot Oil	7	230	750	carbon graphite bearing and spherical seal	24
DN 20 - 50	9000 Sat. Steam	10	185	400	carbon graphite bearing and spherical seal	25 - 27
DN 20 - 50	9000 Hot Oil	7	230	400	carbon graphite bearing and spherical seal	25 - 27
DN 40	HPS Sat. Steam	17	200	400	for corrugators	28
DN 20 - 50	H Sat. Steam	10	185	400	double carbon graphite bearing and spherical seal	29 - 32
DN 65 - 125	H Sat. Steam	10	185	180	double carbon graphite bearing and spherical seal	29 - 32
DN 20 - 50	H Hot Oil	7	230	400	double carbon graphite bearing and spherical seal	29 - 32
DN 65 - 125	H Hot Oil	7	230	350	double carbon graphite bearing and spherical seal	29 - 32
for Air & Hydraulic						33 - 46
DN 10 - 50	14000	60	120	1,500	self-supported or in-the-shaft mounted	33
DN 10 - 50	1005, 1102, 1115	70	120	3,500	for standard applications	34 - 35
DN 10 - 50	1205, 2200, 250	70	120	3,500	for standard applications	34 - 35
DN 10 - 50	355, 452	70	120	3,000	for standard applications	34 - 35
DN 10 - 50	1005, 1102, 1115	70	120	3,500	in-the-shaft mounted	36
DN 10 - 50	D	450	120	20	for high pressure applications	37
DN 10 - 50	AP	400	90	1,500	high pressures & high RPM	38
DN 10 - 50	7100	250	60	500	high pressure hydraulic	39
DN 10 - 50	17 & 21	210	120	250	Tandem design	40
DN 10 - 50	1690, 1790, 1890	210	120	250	DEU-PLEX	41 - 42
DN 10 - 50	1379, 1479	250	80	250	multi-purpose	43
DN 10 - 50	1500	10	120	1,500	DEU-PLEX, for lubricated air	44
DN 10 - 50	1590, 1579	70	120	1,500	DEU-PLEX	45
DN 10 - 50	2620	140	71	5,000	DEU-PLEX, for high RPM	46
for Coolant						47 - 50
DN 10 - 50	1116	70	71	10,000	for standard applications	47
DN 10 - 50	1101	105	71	15,000	coolant, for high RPM	48
DN 10 - 50	1109 & 902	140	71	20,000	dry-run (POP-OFF™), self-supported	49 - 50
for Water in Continuous Casting Plants						51
DN 20 - 40	2400	10	120	100	in-the-shaft mounted	51

Attention!

For applications exceeding given limits and/or unlisted rotor connections, contact **DEUBLIN** for engineering assistance. Please indicate media, size, speed (RPM), pressure, temperature and requested connection.

Please note our "Instructions of Hose Installation and Assembly of **DEUBLIN** Rotating Unions" on page 54.
- **Dimensions in mm.**

Subject to both technical and dimensional changes without prior notice.

Sealing

Original rotating unions used the media pressure to maintain seal contact. Logic indicates that as pressure increases, so do the forces holding the seals together - more pressure = tighter, better sealing. This is why they were called "pressure joints".

However, more pressure on the rotating seal face also meant more friction, higher torque and more wear. The resulting service life was not satisfactory.

DEUBLIN was aware of the disadvantage and applied "Balanced Mechanical Seal Technology", a decisive improvement. This simply means the load or pressure on the seal faces is kept to a minimum regardless of media pressure, resulting in a freer turning union and in longer seal life.

Optimal balance ratio allows for a thin film of "lubricating" media between the seal faces.

In order to attain sealing in a non-pressurised system, the floating seal contact is maintained by the spring pressure (refer to sketch).

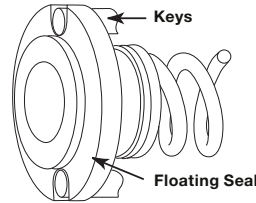
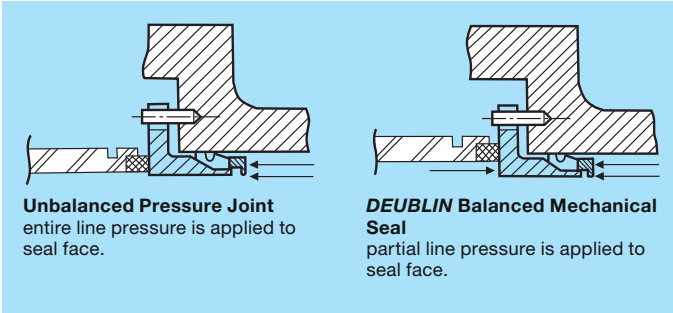

Keyed Floating Seal

Manufacturing

The entire **DEUBLIN** product range is manufactured at the cutting edge of technology from the very first drawing to the final production. Modern CNC machining centres transform highest quality materials into precision components. Cost-effective production is achieved by applying new technology and the most modern equipment.

Once assembled **EVERY** rotating union is dynamically pressure-tested for leakage as part of the final inspection procedure prior to despatch.

The core of a rotating union is the seal combination. Seal faces manufactured from tool steel, carbon graphite, bronze, ceramic, tungsten carbide or silicon carbide are micro-lapped to a surface finish of 0.025 RMS and an optical flatness of 2 light bands. To ensure the above specifications the near perfect flatness is tested under mono-chromatic light (refer to picture).



Micro-Lapped Seals



CNC Machining Centre

Thread Specifications used in this Catalogue

Symbol	Description
1/2 NPT	(American) National Pipe Thread
5/8-18 UNF	Unified National Fine Thread
1-14 UNS	Unified National Special
RH or LH	Right Hand or Left Hand
Rp 1/2	ISO 7/1 (DIN 2999) Pipe Thread (cylindrical internal)

Symbol	Description
G 1/2	ISO 228 (DIN 259) Straight Pipe Thread
M 22x1,5	ISO Metric Thread
R 1/8	ISO 7/1 (DIN 2999) Pipe Thread (tapered external)
Rc 3/4	ISO 7/1 (DIN 2999) Pipe Thread (tapered internal)

Reliability

Years of experience, constant dialogues with customers, in-house and supplier innovations have enabled **DEUBLIN** to offer reliable rotating unions at the cutting edge of technology. The right seal combination compatible to the media guarantees the maximum service life for every particular application.

A clean and efficient warehousing and handling of the union is just as much a prerequisite for our customers as the adherence to the **DEUBLIN** specifications.

The market demands more products with a longer service life at more extreme parameters.

Besides new developments and the constant modification of existing products, it is above all better wear-resistant seal combinations that accommodate these market demands. **DEUBLIN** offers these seal combinations under the designation E.L.S. (Extended Life Sealing).



Service

For **DEUBLIN customer-orientated service** means: customisation and/or newly engineered unions for special requirements, an all-encompassing technical consultation by union selection either from the **DEUBLIN** facility or in the field by one of our representatives, short-term delivery of all selected components and, finally, fast troubleshooting of any and all problems.

Lengthy machine breakdowns are a thing of the past.

A broad assortment of unions is produced for stock and can be procured quickly. An automatic warehousing system enables all required components to be localised fast and effectively.

Lead times for special contractual products are only fractionally longer, for a modern and optimised production and assembly guarantee very short process times.

High-performance CAD systems warrant the realisation of special requirements such as the modification of an existing union or newly engineered designs. The customer receives in short notice the quotation including a technical drawing and price. The production of the rotating unions begins at that moment when the drawing has been confirmed by the customer and returned to the **DEUBLIN** facility.

Repair

Basically, all **DEUBLIN** Rotating Unions can be refurbished at the factory.

After they are returned, disassembly and cleaning begins and all worn parts are replaced with new ones. After assembly and testing, the customer receives back unions that are as good as new with an standard warranty.

When taking advantage of a warranty, the union must be returned UNOPENED. The cause of failure will be ascertained and, if so desired, the customer will receive a report for personal perusal. The result of the findings will decide whether the repair is performed on a charge or on a no-charge basis.

Numerous **DEUBLIN** products can be field repaired by the user. For every degree of wear there is a corresponding rebuilding or repair kit available. These kits can be ordered at the **DEUBLIN**



facility complete with their respective repair instructions (refer to comments under number system).

Number System

DEUBLIN ordering numbers for standard rotating unions consist of 2, 3 or 4 number groups. Each group describes a particular characteristic feature such as application, seal combination or rotor connection (refer to ordering example).

Rebuilding and repair kit numbers differ from their respective rotating union numbers by the insertion of a letter (B or C) which describes the extent of repair. The letter B stands for a rebuilding kit and the letter C for a repair kit (refer to ordering example).

All 54, 55 and 57 Series Rotating Unions are available for use in a potentially explosive atmospheres defined by "ATEX". Unions, that match the requirements for ATEX can be identified by an "X" between the first two number groups.

Ordering example:

255-000-284

└─ rotor
└─ seal combination
└─ model / series / size

250-681

└─ elbow for duoflow design
└─ series / size

255-000B284

└─ rebuilding kit

257-000C

└─ repair kit

255X000-284

└─ ATEX series



DEUBLIN

Rotating Unions 57 Series with Silicon Carbide Seals for Water Service, DN 10 - 50 (Patented)

- monoflow and duoflow design
- self-supported rotating union
- radial housing connection
- balanced mechanical seal
- pinned rotor seal
- easy and quick replacement of sealing components (rotor seal, floating seal)
- ball bearings lubricated for life
- for poor water quality
- 3 vent holes
- forged brass housing
- stainless steel rotor
- special options: threaded vent holes, bearings splash proof, nickel-plated versions

Operating Data

Max. Water Pressure		150 PSI	10 bar
Max. Speed, Rotor with Straight Threads:	Model		
	57-257	3,500 RPM	3,500 min ⁻¹
	357	3,000 RPM	3,000 min ⁻¹
	527-557	2,500 RPM	2,500 min ⁻¹
	657	750 RPM	750 min ⁻¹

Max. Temperature 90 °C > 90 °C consult **DEUBLIN**

For further information please contact **DEUBLIN** or your local representative.

Torque Ratings 57 Series

DN	ft.lbs	Nm
10	0.18	0.25
15	0.37	0.50
20	0.74	1.00
25	1.48	2.00
32	1.62	2.20
40	2.14	2.90
50	3.32	4.50

Seal Combination - Standard

- Carbon Graphite/Silicon Carbide
- long service life

Seal Combination - E.L.S. (Extended Life Sealing)

- Silicon Carbide/Silicon Carbide for severe conditions (poor water quality)

All 54, 55 and 57 Series Rotating Unions are available for use in a potentially explosive atmospheres defined by "ATEX".

Union Repair

The 57 Series is designed for quick, easy replacement of both Floating Seal and the Rotor Seal.

The "57's" seal is seated in a keyed counter bore at the rotor's end. The worn seal simply lifts out and the new one drops right in. Since the entire rotor does not need to be replaced or relapped, the repair is fast, easy and on the spot. As you only replace the seals, the repair cost is very economical.

For Ordering Number of Repair Kit see page 5.

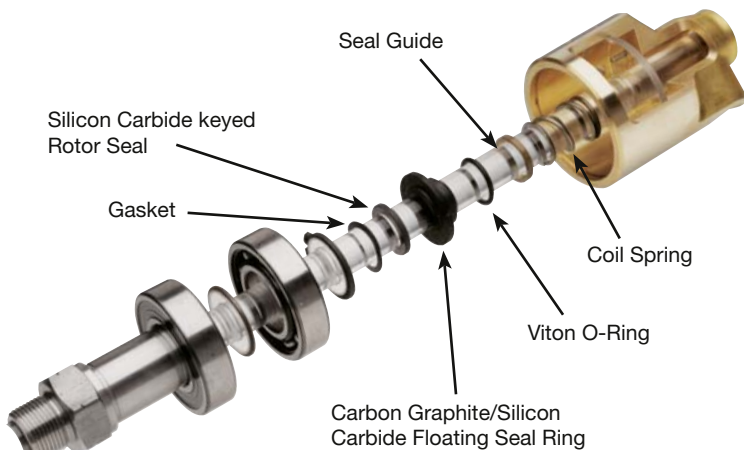

DEUBLIN

Rotating Unions 55 Series for General Purposes, DN 10 - 50



- monoflow and duoflow design
- self-supported rotating union
- radial housing connection
- balanced mechanical seal
- 3 vent holes
- forged brass housing
- stainless steel rotor
- special options:
threaded vent holes,
splash-proof bearings,
nickel-plated
and/or low torque design
- Lubrication Guide page 52

Operating Data

Max. Water Pressure*	Model 55 -555	750 PSI	50 bar
Max. Water Pressure*	Model 655	200 PSI	14 bar
Max. Saturated Steam Pressure (Intermittent)		14 PSI	1 bar
Max. Hot Oil Pressure		100 PSI	6,6 bar
Max. Speed, Rotors with Straight Threads:	Model 55 -255	3,500 RPM	3,500 min ⁻¹
	355	3,000 RPM	3,000 min ⁻¹
	525 -555	2,500 RPM	2,500 min ⁻¹
	655	750 RPM	750 min ⁻¹

Max. Temperature 120 °C > 120 °C consult **DEUBLIN**

* Pressures exceeding 8 bars only permissible with cold water (50°C max.)

For further information please contact **DEUBLIN** or your local representative.

Torque Ratings 55 Series

DN	ft.lbs	Nm
10	0.25	0.34
15	0.35	0.50
20	0.50	0.68
25	1.25	1.80
32	1.25	1.80
40	2.50	3.40
50	3.00	4.07

Seal Combinations - Standard

- Carbon Graphite/Bronze for water
optional:
- Carbon Graphite/Ceramic for hot oil, hot water and saturated steam
- multi-purpose applications

Seal Combination - E.L.S. (Extended Life Sealing)

- Tungsten Carbide/Ceramic for severe conditions (poor water quality), max. temperature 90°C

All 54, 55 and 57 Series Rotating Unions are available for use in a potentially explosive atmospheres defined by "ATEX".

Illustration shows duoflow with fixed supply pipe. Monoflow units have pipe plugs instead of an elbow.

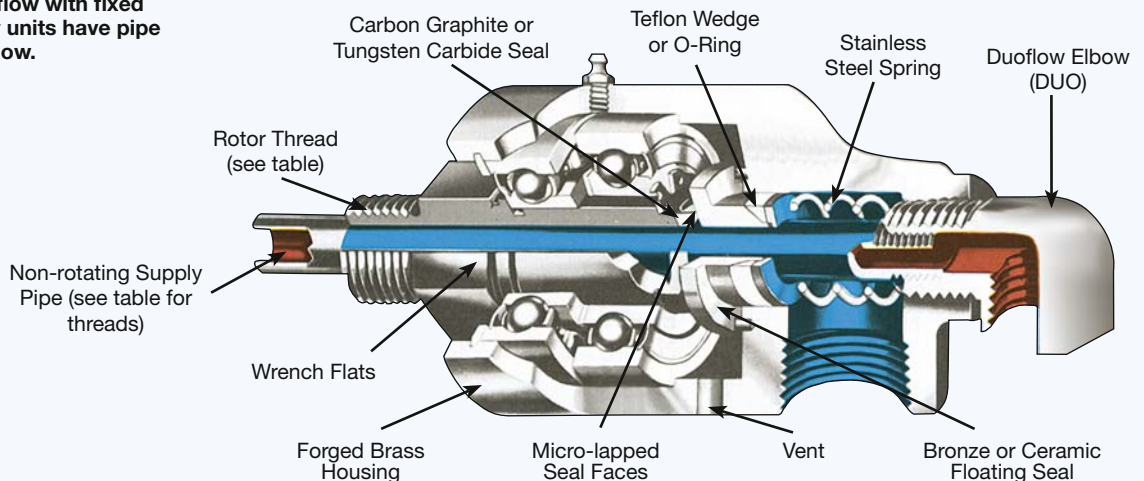

57 and 55 Series - Monoflow Rotating Unions DN 10 - 50

Monoflow unions are used when supply and return lines are connected to opposite sides of the cylinder or roll.

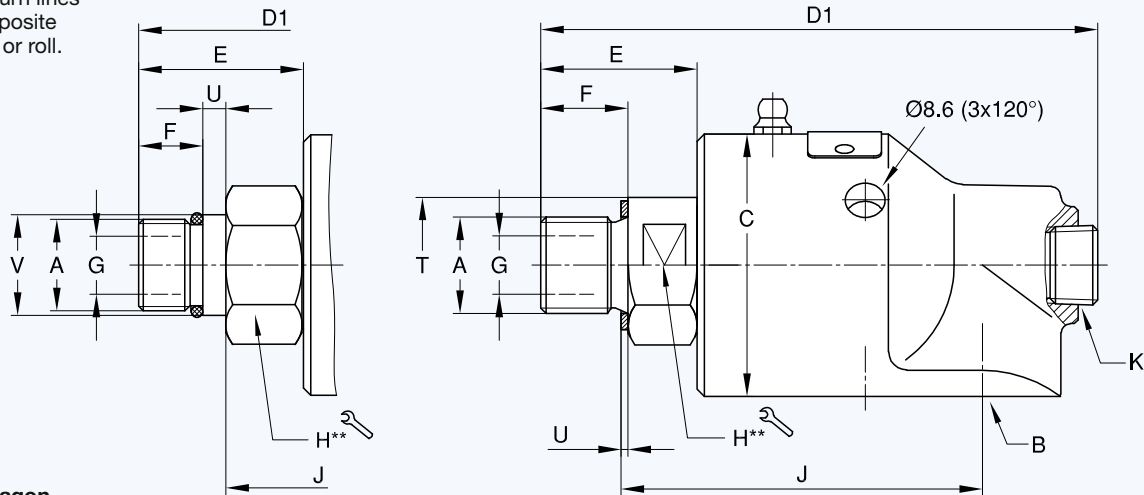

Pilot Type Rotor

** DN 10 - 20 = hexagon
 DN 25 - 50 = two wrench flats

DN	B	Ordering No. (Basic Models)				A Rotor Connections	C	D1	E	F	G	H	J	K	T	U	V	kg
		Model 57 STD	Model 57 E.L.S.	Model 55 STD	Model 55 E.L.S.													
10	3/8 NPT	57-000-094	57-050-094	55-000-094	55-147-192	G 3/8 RH	45	100	26	16	9,5	22	64	1/4	-	1,5	-	0,6
	3/8 NPT	57-000-095	57-050-095	55-000-095	55-147-193	G 3/8 LH	45	100	26	16	9,5	22	64	1/4	-	1,5	-	0,6
	G 3/8	57-130-094	57-145-094	55-655-094	55-842-192	G 3/8 RH	45	100	26	16	9,5	22	64	1/4	-	1,5	-	0,6
	G 3/8	57-130-095	57-145-095	55-655-095	55-842-193	G 3/8 LH	45	100	26	16	9,5	22	64	1/4	-	1,5	-	0,6
15	1/2 NPT	157-000-151	157-050-151	155-000-151	155-208-252	G 1/2 RH	57	119	35	19	12,7	30	79	3/8	-	1,5	-	1,2
	1/2 NPT	157-000-152	157-050-152	155-000-152	155-208-253	G 1/2 LH	57	119	35	19	12,7	30	79	3/8	-	1,5	-	1,2
	G 1/2	157-130-151	157-145-151	155-122-151	155-754-252	G 1/2 RH	57	119	35	19	12,7	30	79	3/8	-	1,5	-	1,2
	G 1/2	157-130-152	157-145-152	155-122-152	155-754-253	G 1/2 LH	57	119	35	19	12,7	30	79	3/8	-	1,5	-	1,2
	G 1/2	157-130-738	157-145-738	155-122-738	155-754-739	M 20 x 1,5 RH	57	121	37	14	12,7	30	79	3/8	-	5	22g6	1,2
20	G 1/2	157-130-835	157-145-835	155-122-835	155-754-833	M 20 x 1,5 LH	57	121	37	14	12,7	30	79	3/8	-	5	22g6	1,2
	3/4 NPT	257-000-284	257-050-284	255-000-284	255-052-445	G 3/4 RH	73	136	34	19	17,5	36	95	1/2	-	2	-	2,1
	3/4 NPT	257-000-285	257-050-285	255-000-285	255-052-446	G 3/4 LH	73	136	34	19	17,5	36	95	1/2	-	2	-	2,1
	G 3/4	257-130-284	257-145-284	255-269-284	255-421-445	G 3/4 RH	73	136	34	19	17,5	36	95	1/2	-	2	-	2,1
	G 3/4	257-130-285	257-145-285	255-269-285	255-421-446	G 3/4 LH	73	136	34	19	17,5	36	95	1/2	-	2	-	2,1
	G 3/4	257-130-014	257-145-014	255-269-014	255-421-469	M 35 x 1,5 RH	73	140	38	15	17,5	41	102	1/2	-	2	-	2,2
	G 3/4	257-130-015	257-145-015	255-269-015	255-421-470	M 35 x 1,5 LH	73	140	38	15	17,5	41	102	1/2	-	2	-	2,2
25	G 3/4	257-130-048	257-145-048	255-269-458	255-421-936	M 27 x 1,5 RH	73	137	35	15	17,5	36	92	1/2	-	6	28g6	2,1
	G 3/4	257-130-104	257-145-104	255-269-459	255-421-937	M 27 x 1,5 LH	73	137	35	15	17,5	36	92	1/2	-	6	28g6	2,1
	1 NPT	357-000-222	357-050-222	355-000-222	355-064-378	G 1 RH	83	163	42	22	25	36	108	3/4	45	2	-	3,1
	1 NPT	357-000-223	357-050-223	355-000-223	355-064-379	G 1 LH	83	163	42	22	25	36	108	3/4	45	2	-	3,1
	G 1	357-130-222	357-145-222	355-204-222	355-215-378	G 1 RH	83	163	42	22	25	36	108	3/4	45	2	-	3,1
32	G 1	357-130-223	357-145-223	355-204-223	355-215-379	G 1 LH	83	163	42	22	25	36	108	3/4	45	2	-	3,1
	G 1	357-130-235	357-145-235	355-204-235	355-215-381	M 35 x 1,5 RH	83	157	36	15	25	36	108	3/4	45	2	-	3,1
	G 1	357-130-236	357-145-236	355-204-236	355-215-382	M 35 x 1,5 LH	83	157	36	15	25	36	108	3/4	45	2	-	3,1
	1 1/4 NPT	527-000-054	527-050-054	525-000-054	525-097-122	G 1 1/4 RH	91	189	54	28	31,8	46	119	1	58	2	-	4,1
40	1 1/4 NPT	527-000-055	527-050-055	525-000-055	525-097-123	G 1 1/4 LH	91	189	54	28	31,8	46	119	1	58	2	-	4,1
	G 1 1/4	527-130-054	527-145-054	525-301-054	525-398-122	G 1 1/4 RH	91	189	54	28	31,8	46	119	1	58	2	-	4,1
	G 1 1/4	527-130-055	527-145-055	525-301-055	525-398-123	G 1 1/4 LH	91	189	54	28	31,8	46	119	1	58	2	-	4,1
	1 1/2 NPT	557-000-198	557-050-198	555-000-198	555-033-288	G 1 1/2 RH	108	228	72	29	38	55	149	1 1/4	65	2	-	6,7
	1 1/2 NPT	557-000-199	557-050-199	555-000-199	555-033-289	G 1 1/2 LH	108	228	72	29	38	55	149	1 1/4	65	2	-	6,7
50	G 1 1/2	557-130-198	557-145-198	555-385-198	555-378-288	G 1 1/2 RH	108	228	72	29	38	55	149	1 1/4	65	2	-	6,7
	G 1 1/2	557-130-199	557-145-199	555-385-199	555-378-289	G 1 1/2 LH	108	228	72	29	38	55	149	1 1/4	65	2	-	6,7
	G 1 1/2	557-130-200	557-145-200	555-385-200	555-378-418	M 50 x 1,5 RH	108	222	66	23	38	55	149	1 1/4	65	2	-	6,5
	G 1 1/2	557-130-201	557-145-201	555-385-201	555-378-419	M 50 x 1,5 LH	108	222	66	23	38	55	149	1 1/4	65	2	-	6,5
50	2 NPT	657-000-124	657-050-124	655-500-124	655-502-124	G 2 RH	118	248	65	29	47,6	60	165	1 1/4	70	2,5	-	7,6
	2 NPT	657-000-125	657-050-125	655-500-125	655-502-125	G 2 LH	118	248	65	29	47,6	60	165	1 1/4	70	2,5	-	7,6
	G 2	657-130-124	657-145-124	655-527-124	655-930-124	G 2 RH	118	248	65	29	47,6	60	165	1 1/4	70	2,5	-	7,6
	G 2	657-130-125	657-145-125	655-527-125	655-930-125	G 2 LH	118	248	65	29	47,6	60	165	1 1/4	70	2,5	-	7,6

57 and 55 Series - Duoflow Rotating Unions DN 10 - 50 for Threaded Supply Pipe

Duoflow unions are used when supply and return lines are connected to one side of the cylinder or roll; non-supported pipe lengths no longer than 4 x D2; max. speed 1000 RPM; for higher speeds divided supply pipes must be used (refer to page 11/12)

For rotating unions with pilot rotor, additional basic models and weight refer to page 8.

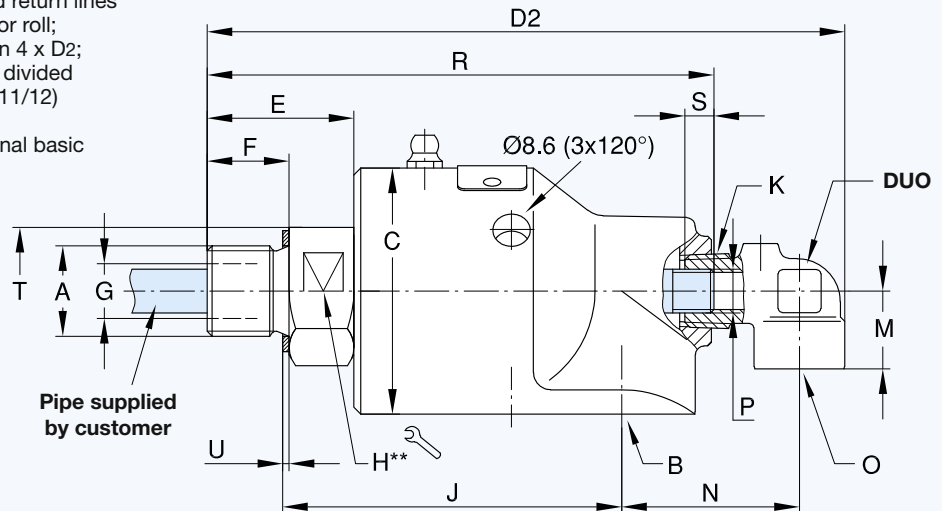

** DN 10 - 20 = hexagon
 DN 25 - 50 = two wrench flats

DN	B	O	Ordering No.		A Rotor Connections	C Ø	D2	E	F	G Ø	H H	J	K NPT	M	N	P Pipe	R	S	T Ø	U	
			Model 57 STD	DUO																	
10	3/8 NPT	1/4 NPT	57-000-094	55-120	G 3/8 RH	45	124	26	16	9,5	22	64	1/4	18	36	M 6	99	8	-	1,5	
	3/8 NPT	1/4 NPT	57-000-095	55-120	G 3/8 LH	45	124	26	16	9,5	22	64	1/4	18	36	M 6	99	8	-	1,5	
	G 3/8	G 1/4	57-130-094	55-121	G 3/8 RH	45	124	26	16	9,5	22	64	1/4	18	36	M 6	99	8	-	1,5	
	G 3/8	G 1/4	57-130-095	55-121	G 3/8 LH	45	124	26	16	9,5	22	64	1/4	18	36	M 6	99	8	-	1,5	
15	1/2 NPT	3/8 NPT	157-000-151	155-199	G 1/2 RH	57	147	35	19	12,7	30	79	3/8	18	40	G 1/8	118	8	-	1,5	
	1/2 NPT	3/8 NPT	157-000-152	155-199	G 1/2 LH	57	147	35	19	12,7	30	79	3/8	18	40	G 1/8	118	8	-	1,5	
	G 1/2	G 3/8	157-130-151	155-581	G 1/2 RH	57	147	35	19	12,7	30	79	3/8	18	40	G 1/8	118	8	-	1,5	
	G 1/2	G 3/8	157-130-152	155-581	G 1/2 LH	57	147	35	19	12,7	30	79	3/8	18	40	G 1/8	118	8	-	1,5	
	G 1/2	G 3/8	157-130-738	155-581	M 20 x 1,5	RH	57	149	37	14	12,7	30	79	3/8	18	40	G 1/8	120	8	-	-
	G 1/2	G 3/8	157-130-835	155-581	M 20 x 1,5	LH	57	149	37	14	12,7	30	79	3/8	18	40	G 1/8	120	8	-	-
20	3/4 NPT	1/2 NPT	257-000-284	250-368	G 3/4 RH	73	171	34	19	17,5	36	95	1/2	26	46	G 1/4	137	12	-	2	
	3/4 NPT	1/2 NPT	257-000-285	250-368	G 3/4 LH	73	171	34	19	17,5	36	95	1/2	26	46	G 1/4	137	12	-	2	
	G 3/4	G 1/2	257-130-284	251-351	G 3/4 RH	73	171	34	19	17,5	36	95	1/2	26	46	G 1/4	137	12	-	2	
	G 3/4	G 1/2	257-130-285	251-351	G 3/4 LH	73	171	34	19	17,5	36	95	1/2	26	46	G 1/4	137	12	-	2	
	G 3/4	G 1/2	257-130-014	251-351	M 35 x 1,5	RH	73	174	38	15	17,5	41	102	1/2	26	46	G 1/4	141	12	-	2
	G 3/4	G 1/2	257-130-015	251-351	M 35 x 1,5	LH	73	174	38	15	17,5	41	102	1/2	26	46	G 1/4	141	12	-	2
	G 3/4	G 1/2	257-130-048	251-351	M 27 x 1,5	RH	73	172	35	15	17,5	36	92	1/2	26	46	G 1/4	137	12	-	-
	G 3/4	G 1/2	257-130-104	251-351	M 27 x 1,5	LH	73	172	35	15	17,5	36	92	1/2	26	46	G 1/4	137	12	-	-
25	1 NPT	1/2 NPT	357-000-222	350-255	G 1 RH	83	200	42	22	25	36	108	3/4	28	59	G 3/8	161	12	45	2	
	1 NPT	1/2 NPT	357-000-223	350-255	G 1 LH	83	200	42	22	25	36	108	3/4	28	59	G 3/8	161	12	45	2	
	G 1	G 1/2	357-130-222	350-912	G 1 RH	83	200	42	22	25	36	108	3/4	28	59	G 3/8	161	12	45	2	
	G 1	G 1/2	357-130-223	350-912	G 1 LH	83	200	42	22	25	36	108	3/4	28	59	G 3/8	161	12	45	2	
	G 1	G 1/2	357-130-235	350-912	M 35 x 1,5	RH	83	194	36	15	25	36	108	3/4	28	59	G 3/8	155	12	45	2
	G 1	G 1/2	357-130-236	350-912	M 35 x 1,5	LH	83	194	36	15	25	36	108	3/4	28	59	G 3/8	155	12	45	2
32	1 1/4 NPT	3/4 NPT	527-000-054	525-079	G 1 1/4 RH	91	234	54	28	31,8	46	119	1	35	72	G 1/2	186	14	58	2	
	1 1/4 NPT	3/4 NPT	527-000-055	525-079	G 1 1/4 LH	91	234	54	28	31,8	46	119	1	35	72	G 1/2	186	14	58	2	
	G 1 1/4	G 3/4	527-130-054	525-594	G 1 1/4 RH	91	234	54	28	31,8	46	119	1	35	72	G 1/2	186	14	58	2	
	G 1 1/4	G 3/4	527-130-055	525-594	G 1 1/4 LH	91	234	54	28	31,8	46	119	1	35	72	G 1/2	186	14	58	2	
40	1 1/2 NPT	3/4 NPT	557-000-198	450-221	G 1 1/2 RH	108	270	72	29	38	55	149	1 1/4	38	76	G 3/4	223	16	65	2	
	1 1/2 NPT	3/4 NPT	557-000-199	450-221	G 1 1/2 LH	108	270	72	29	38	55	149	1 1/4	38	76	G 3/4	223	16	65	2	
	G 1 1/2	G 3/4	557-130-198	451-171	G 1 1/2 RH	108	270	72	29	38	55	149	1 1/4	38	76	G 3/4	223	16	65	2	
	G 1 1/2	G 3/4	557-130-199	451-171	G 1 1/2 LH	108	270	72	29	38	55	149	1 1/4	38	76	G 3/4	223	16	65	2	
	G 1 1/2	G 3/4	557-130-200	451-171	M 50 x 1,5	RH	108	264	66	23	38	55	149	1 1/4	38	76	G 3/4	216	16	65	2
	G 1 1/2	G 3/4	557-130-201	451-171	M 50 x 1,5	LH	108	264	66	23	38	55	149	1 1/4	38	76	G 3/4	216	16	65	2
50	2 NPT	1 1/4 NPT	657-000-124	451-242	G 2 RH	118	312	65	29	47,6	60	165	1 1/4	45	96	G 1	252	26	70	2,5	
	2 NPT	1 1/4 NPT	657-000-125	451-242	G 2 LH	118	312	65	29	47,6	60	165	1 1/4	45	96	G 1	252	26	70	2,5	
	G 2	G 1 1/4	657-130-124	450-534	G 2 RH	118	312	65	29	47,6	60	165	1 1/4	45	96	G 1	252	26	70	2,5	
	G 2	G 1 1/4	657-130-125	450-534	G 2 LH	118	312	65	29	47,6	60	165	1 1/4	45	96	G 1	252	26	70	2,5	

57 and 55 Series - Duoflow Rotating Unions DN 10 - 50 for Rotating Supply Pipe

Duoflow unions are used when supply and return lines are connected to one side of the cylinder or roll; max. speed 1000 RPM; for higher speeds divided supply pipes must be used (refer to page 11/12)

For rotating unions with pilot rotor, additional basic models and weight refer to page 8.

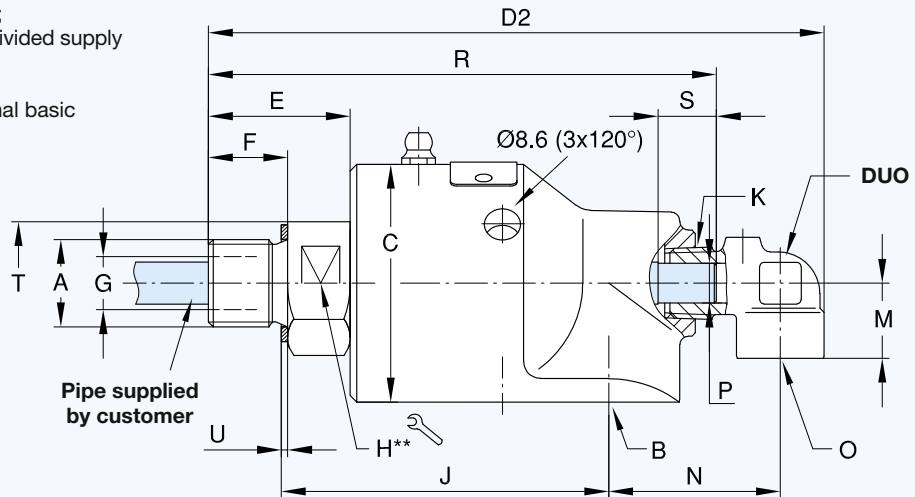

** DN 10 - 20 = hexagon
 DN 25 - 50 = two wrench flats

DN	B	O	Ordering No.		A Rotor Connections	C Ø	D2	E	F	G Ø	H Ø	J	K NPT	M	N	P Pipe Ø d11	R	S	T Ø	U
			Model 57 STD	DUO																
10	3/8 NPT	1/4 NPT	57-000-094	55-446	G 3/8 RH	45	124	26	16	9,5	22	64	1/4	18	36	5,8	103	20	-	1,5
	3/8 NPT	1/4 NPT	57-000-095	55-446	G 3/8 LH	45	124	26	16	9,5	22	64	1/4	18	36	5,8	103	20	-	1,5
	G 3/8	G 1/4	57-130-094	55-807	G 3/8 RH	45	124	26	16	9,5	22	64	1/4	18	36	5,8	103	20	-	1,5
	G 3/8	G 1/4	57-130-095	55-807	G 3/8 LH	45	124	26	16	9,5	22	64	1/4	18	36	5,8	103	20	-	1,5
15	1/2 NPT	3/8 NPT	157-000-151	155-471	G 1/2 RH	57	147	35	19	12,7	30	79	3/8	18	40	9,8	124	30	-	1,5
	1/2 NPT	3/8 NPT	157-000-152	155-471	G 1/2 LH	57	147	35	19	12,7	30	79	3/8	18	40	9,8	124	30	-	1,5
	G 1/2	G 3/8	157-130-151	155-709	G 1/2 RH	57	147	35	19	12,7	30	79	3/8	18	40	9,8	124	30	-	1,5
	G 1/2	G 3/8	157-130-152	155-709	G 1/2 LH	57	147	35	19	12,7	30	79	3/8	18	40	9,8	124	30	-	1,5
	G 1/2	G 3/8	157-130-738	155-709	M 20 x 1,5 RH	57	149	37	14	12,7	30	79	3/8	18	40	9,8	124	30	-	-
	G 1/2	G 3/8	157-130-835	155-709	M 20 x 1,5 LH	57	149	37	14	12,7	30	79	3/8	18	40	9,8	124	30	-	-
20	3/4 NPT	1/2 NPT	257-000-284	250-681	G 3/4 RH	73	171	34	19	17,5	36	95	1/2	26	46	12,8	143	32	-	2
	3/4 NPT	1/2 NPT	257-000-285	250-681	G 3/4 LH	73	171	34	19	17,5	36	95	1/2	26	46	12,8	143	32	-	2
	G 3/4	G 1/2	257-130-284	251-352	G 3/4 RH	73	171	34	19	17,5	36	95	1/2	26	46	12,8	143	32	-	2
	G 3/4	G 1/2	257-130-285	251-352	G 3/4 LH	73	171	34	19	17,5	36	95	1/2	26	46	12,8	143	32	-	2
	G 3/4	G 1/2	257-130-014	251-352	M 35 x 1,5 RH	73	174	38	15	17,5	41	102	1/2	26	46	12,8	146	32	-	2
	G 3/4	G 1/2	257-130-015	251-352	M 35 x 1,5 LH	73	174	38	15	17,5	41	102	1/2	26	46	12,8	146	32	-	2
	G 3/4	G 1/2	257-130-048	251-352	M 27 x 1,5 RH	73	172	35	15	17,5	36	92	1/2	26	46	12,8	143	32	-	-
	G 3/4	G 1/2	257-130-104	251-352	M 27 x 1,5 LH	73	172	35	15	17,5	36	92	1/2	26	46	12,8	143	32	-	-
25	1 NPT	1/2 NPT	357-000-222	350-347	G 1 RH	83	200	42	22	25	36	108	3/4	28	59	15,8	171	35	45	2
	1 NPT	1/2 NPT	357-000-223	350-347	G 1 LH	83	200	42	22	25	36	108	3/4	28	59	15,8	171	35	45	2
	G 1	G 1/2	357-130-222	350-772	G 1 RH	83	200	42	22	25	36	108	3/4	28	59	15,8	171	35	45	2
	G 1	G 1/2	357-130-223	350-772	G 1 LH	83	200	42	22	25	36	108	3/4	28	59	15,8	171	35	45	2
	G 1	G 1/2	357-130-235	350-772	M 35 x 1,5 RH	83	194	36	15	25	36	108	3/4	28	59	15,8	165	35	45	2
	G 1	G 1/2	357-130-236	350-772	M 35 x 1,5 LH	83	194	36	15	25	36	108	3/4	28	59	15,8	165	35	45	2
32	1 1/4 NPT	3/4 NPT	527-000-054	525-237	G 1 1/4 RH	91	234	54	28	31,8	46	119	1	35	72	21,8	196	40	58	2
	1 1/4 NPT	3/4 NPT	527-000-055	525-237	G 1 1/4 LH	91	234	54	28	31,8	46	119	1	35	72	21,8	196	40	58	2
	G 1 1/4	G 3/4	527-130-054	525-480	G 1 1/4 RH	91	234	54	28	31,8	46	119	1	35	72	21,8	196	40	58	2
	G 1 1/4	G 3/4	527-130-055	525-480	G 1 1/4 LH	91	234	54	28	31,8	46	119	1	35	72	21,8	196	40	58	2
40	1 1/2 NPT	3/4 NPT	557-000-198	450-468	G 1 1/2 RH	108	270	72	29	38	55	149	1 1/4	38	76	25,8	238	44	65	2
	1 1/2 NPT	3/4 NPT	557-000-199	450-468	G 1 1/2 LH	108	270	72	29	38	55	149	1 1/4	38	76	25,8	238	44	65	2
	G 1 1/2	G 3/4	557-130-198	451-173	G 1 1/2 RH	108	270	72	29	38	55	149	1 1/4	38	76	25,8	238	44	65	2
	G 1 1/2	G 3/4	557-130-199	451-173	G 1 1/2 LH	108	270	72	29	38	55	149	1 1/4	38	76	25,8	238	44	65	2
	G 1 1/2	G 3/4	557-130-200	451-173	M 50 x 1,5 RH	108	264	66	23	38	55	149	1 1/4	38	76	25,8	232	44	65	2
	G 1 1/2	G 3/4	557-130-201	451-173	M 50 x 1,5 LH	108	264	66	23	38	55	149	1 1/4	38	76	25,8	232	44	65	2
50	2 NPT	1 1/4 NPT	657-000-124	450-625	G 2 RH	118	312	65	29	47,6	60	165	1 1/4	45	96	31,8	253	50	70	2,5
	2 NPT	1 1/4 NPT	657-000-125	450-625	G 2 LH	118	312	65	29	47,6	60	165	1 1/4	45	96	31,8	253	50	70	2,5
	G 2	G 1 1/4	657-130-124	450-612	G 2 RH	118	312	65	29	47,6	60	165	1 1/4	45	96	32,1	253	50	70	2,5
	G 2	G 1 1/4	657-130-125	450-612	G 2 LH	118	312	65	29	47,6	60	165	1 1/4	45	96	32,1	253	50	70	2,5

57 and 55 Series - Duoflow Rotating Unions DN 10 - 50 for Divided Supply Pipe

Duoflow unions are used when supply and return lines are connected to one side of the cylinder or roll; soldered supply pipe; non-supported pipe lengths no longer than 4 x D2; max. speed 3500 RPM;

For rotating unions with pilot rotor, additional basic models and weight refer to page 8.

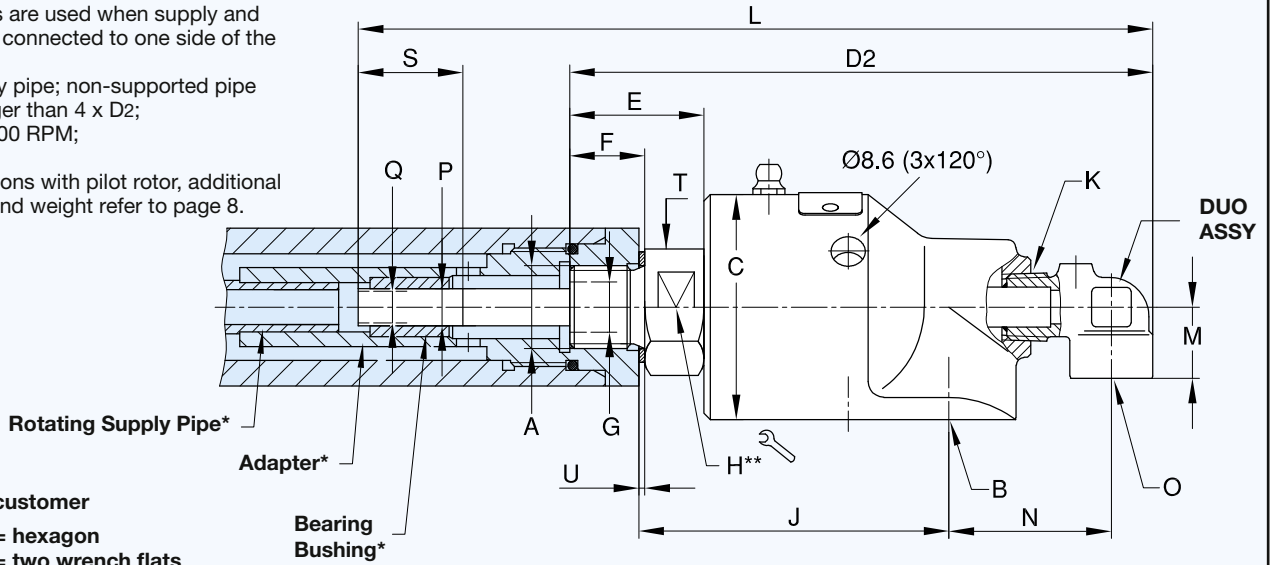

* supplied by customer

** DN 10 - 20 = hexagon
DN 25 - 50 = two wrench flats

DN	B	O	Ordering No.		A Rotor Connections	C ∅	D2	E	F	G ∅	H	J	K NPT	L	M	N	P ∅ H9	Q ∅	S	T ∅	U
			Model 57 STD	DUO																	
10	3/8 NPT	1/4 NPT	57-000-094	55-445	G 3/8 RH	45	124	26	16	9,5	22	64	1/4	171	18	36	6	5	55	-	1,5
	3/8 NPT	1/4 NPT	57-000-095	55-445	G 3/8 LH	45	124	26	16	9,5	22	64	1/4	171	18	36	6	5	55	-	1,5
	G 3/8	G 1/4	57-130-094	55-843	G 3/8 RH	45	124	26	16	9,5	22	64	1/4	171	18	36	6	5	55	-	1,5
	G 3/8	G 1/4	57-130-095	55-843	G 3/8 LH	45	124	26	16	9,5	22	64	1/4	171	18	36	6	5	55	-	1,5
15	1/2 NPT	3/8 NPT	157-000-151	155-470	G 1/2 RH	57	147	35	19	12,7	30	79	3/8	201	18	40	10	8	60	-	1,5
	1/2 NPT	3/8 NPT	157-000-152	155-470	G 1/2 LH	57	147	35	19	12,7	30	79	3/8	201	18	40	10	8	60	-	1,5
	G 1/2	G 3/8	157-130-151	150-232	G 1/2 RH	57	147	35	19	12,7	30	79	3/8	201	18	40	10	8	60	-	1,5
	G 1/2	G 3/8	157-130-152	150-232	G 1/2 LH	57	147	35	19	12,7	30	79	3/8	201	18	40	10	8	60	-	1,5
	G 1/2	G 3/8	157-130-738	150-232	M 20 x 1,5 RH	57	149	37	14	12,7	30	79	3/8	201	18	40	10	8	60	-	-
20	3/4 NPT	1/2 NPT	257-000-284	250-680	G 3/4 RH	73	171	34	19	17,5	36	95	1/2	208	26	46	13	11	60	-	2
	3/4 NPT	1/2 NPT	257-000-285	250-680	G 3/4 LH	73	171	34	19	17,5	36	95	1/2	208	26	46	13	11	60	-	2
	G 3/4	G 1/2	257-130-284	251-551	G 3/4 RH	73	171	34	19	17,5	36	95	1/2	208	26	46	13	11	60	-	2
	G 3/4	G 1/2	257-130-285	251-551	G 3/4 LH	73	171	34	19	17,5	36	95	1/2	208	26	46	13	11	60	-	2
	G 3/4	G 1/2	257-130-014	251-551	M 35 x 1,5 RH	73	174	38	15	17,5	41	102	1/2	208	26	46	13	11	60	-	2
	G 3/4	G 1/2	257-130-015	251-551	M 35 x 1,5 LH	73	174	38	15	17,5	41	102	1/2	208	26	46	13	11	60	-	2
	G 3/4	G 1/2	257-130-048	251-551	M 27 x 1,5 RH	73	172	35	15	17,5	36	92	1/2	208	26	46	13	11	60	-	-
25	1 NPT	1/2 NPT	357-000-222	350-366	G 1 RH	83	200	42	22	25	36	108	3/4	272	28	59	16	14	60	45	2
	1 NPT	1/2 NPT	357-000-223	350-366	G 1 LH	83	200	42	22	25	36	108	3/4	272	28	59	16	14	60	45	2
	G 1	G 1/2	357-130-222	350-990	G 1 RH	83	200	42	22	25	36	108	3/4	272	28	59	16	14	60	45	2
	G 1	G 1/2	357-130-223	350-990	G 1 LH	83	200	42	22	25	36	108	3/4	272	28	59	16	14	60	45	2
	G 1	G 1/2	357-130-235	350-990	M 35 x 1,5 RH	83	194	36	15	25	36	108	3/4	272	28	59	16	14	60	45	2
	G 1	G 1/2	357-130-236	350-990	M 35 x 1,5 LH	83	194	36	15	25	36	108	3/4	272	28	59	16	14	60	45	2
32	1 1/4 NPT	3/4 NPT	527-000-054	525-236	G 1 1/4 RH	91	234	54	28	31,8	46	119	1	285	35	72	22	20	60	58	2
	1 1/4 NPT	3/4 NPT	527-000-055	525-236	G 1 1/4 LH	91	234	54	28	31,8	46	119	1	285	35	72	22	20	60	58	2
	G 1 1/4	G 3/4	527-130-054	525-931	G 1 1/4 RH	91	234	54	28	31,8	46	119	1	285	35	72	22	20	60	58	2
	G 1 1/4	G 3/4	527-130-055	525-931	G 1 1/4 LH	91	234	54	28	31,8	46	119	1	285	35	72	22	20	60	58	2
40	1 1/2 NPT	3/4 NPT	557-000-198	450-467	G 1 1/2 RH	108	270	72	29	38	55	149	1 1/4	319	38	76	26	24	60	65	2
	1 1/2 NPT	3/4 NPT	557-000-199	450-467	G 1 1/2 LH	108	270	72	29	38	55	149	1 1/4	319	38	76	26	24	60	65	2
	G 1 1/2	G 3/4	557-130-198	451-274	G 1 1/2 RH	108	270	72	29	38	55	149	1 1/4	319	38	76	26	24	60	65	2
	G 1 1/2	G 3/4	557-130-199	451-274	G 1 1/2 LH	108	270	72	29	38	55	149	1 1/4	319	38	76	26	24	60	65	2
	G 1 1/2	G 3/4	557-130-200	451-274	M 50 x 1,5 RH	108	264	66	23	38	55	149	1 1/4	319	38	76	26	24	60	65	2
	G 1 1/2	G 3/4	557-130-201	451-274	M 50 x 1,5 LH	108	264	66	23	38	55	149	1 1/4	319	38	76	26	24	60	65	2
50	2 NPT	1 1/4 NPT	657-000-124	655-966	G 2 RH	118	312	65	29	47,6	60	165	1 1/4	382	45	96	34	31	60	70	2,5
	2 NPT	1 1/4 NPT	657-000-125	655-966	G 2 LH	118	312	65	29	47,6	60	165	1 1/4	382	45	96	34	31	60	70	2,5
	G 2	G 1 1/4	657-130-124	655-174	G 2 RH	118	312	65	29	47,6	60	165	1 1/4	382	45	96	34	31	60	70	2,5
	G 2	G 1 1/4	657-130-125	655-174	G 2 LH	118	312	65	29	47,6	60	165	1 1/4	382	45	96	34	31	60	70	2,5

57 and 55 Series - Duoflow Rotating Unions DN 10 - 50 for Divided, Self-Centering Supply Pipe

Duoflow unions are used when supply and return lines are connected to one side of the cylinder or roll; fixed self-centering supply pipe; max. speed 3500 RPM;

For rotating unions with pilot rotor, additional basic models and weight refer to page 8.

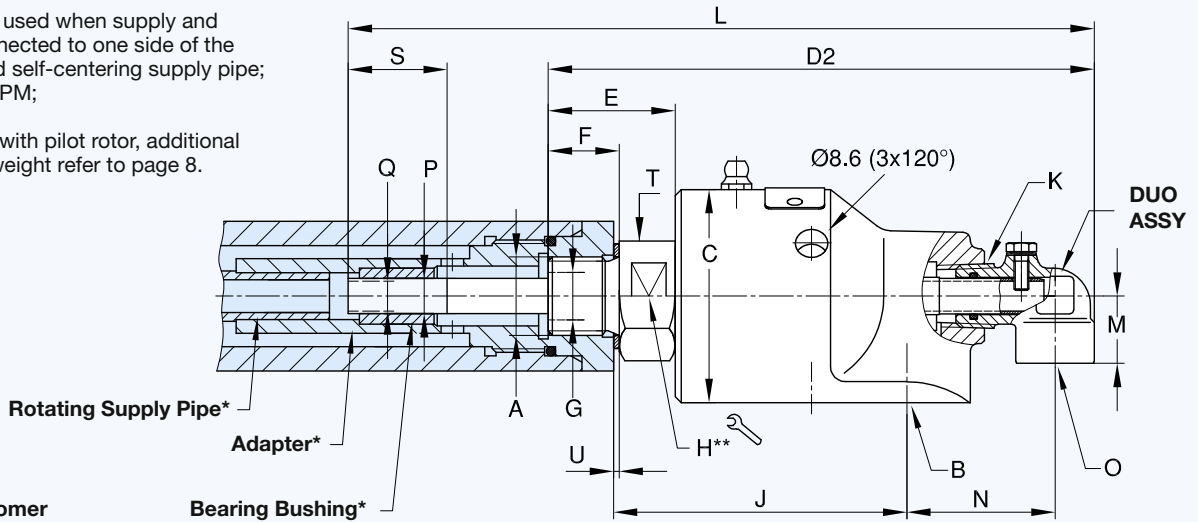

* supplied by customer

** DN 10 - 20 = hexagon
DN 25 - 50 = two wrench flats

DN	B	O	Ordering No.		A		C	D ₂	E	F	G	H	J	K	L	M	N	P	Q	S	T	U	
			Model 57 STD	DUO	Rotor Connections																		
10	3/8 NPT	1/4 NPT	57-000-094	---	G 3/8	RH																	
	3/8 NPT	1/4 NPT	57-000-095	---	G 3/8	LH																	
	G 3/8	G 1/4	57-130-094	---	G 3/8	RH																	
	G 3/8	G 1/4	57-130-095	---	G 3/8	LH																	
15	1/2 NPT	3/8 NPT	157-000-151	155-797	G 1/2	RH	57	147	35	19	12,7	30	79	3/8	201	18	40	10	8	60	-	1,5	
	1/2 NPT	3/8 NPT	157-000-152	155-797	G 1/2	LH	57	147	35	19	12,7	30	79	3/8	201	18	40	10	8	60	-	1,5	
	G 1/2	G 3/8	157-130-151	155-981	G 1/2	RH	57	147	35	19	12,7	30	79	3/8	201	18	40	10	8	60	-	1,5	
	G 1/2	G 3/8	157-130-152	155-981	G 1/2	LH	57	147	35	19	12,7	30	79	3/8	201	18	40	10	8	60	-	1,5	
	G 1/2	G 3/8	157-130-738	155-981	M 20 x 1,5	RH	57	149	37	14	12,7	30	79	3/8	201	18	40	10	8	60	-	-	
	G 1/2	G 3/8	157-130-835	155-981	M 20 x 1,5	LH	57	149	37	14	12,7	30	79	3/8	201	18	40	10	8	60	-	-	
20	3/4 NPT	1/2 NPT	257-000-284	250-994	G 3/4	RH	73	171	34	19	17,5	36	95	1/2	208	26	46	13	11	60	-	2	
	3/4 NPT	1/2 NPT	257-000-285	250-994	G 3/4	LH	73	171	34	19	17,5	36	95	1/2	208	26	46	13	11	60	-	2	
	G 3/4	G 1/2	257-130-284	251-371	G 3/4	RH	73	171	34	19	17,5	36	95	1/2	208	26	46	13	11	60	-	2	
	G 3/4	G 1/2	257-130-285	251-371	G 3/4	LH	73	171	34	19	17,5	36	95	1/2	208	26	46	13	11	60	-	2	
	G 3/4	G 1/2	257-130-014	251-371	M 35 x 1,5	RH	73	174	38	15	17,5	41	102	1/2	208	26	46	13	11	60	-	2	
	G 3/4	G 1/2	257-130-015	251-371	M 35 x 1,5	LH	73	174	38	15	17,5	41	102	1/2	208	26	46	13	11	60	-	2	
	G 3/4	G 1/2	257-130-048	251-371	M 27 x 1,5	RH	73	172	35	15	17,5	36	92	1/2	208	26	46	13	11	60	-	-	
25	1 NPT	1/2 NPT	357-000-222	350-974	G 1	RH	83	200	42	22	25	36	108	3/4	272	28	59	16	14	60	45	2	
	1 NPT	1/2 NPT	357-000-223	350-974	G 1	LH	83	200	42	22	25	36	108	3/4	272	28	59	16	14	60	45	2	
	G 1	G 1/2	357-130-222	351-173	G 1	RH	83	200	42	22	25	36	108	3/4	272	28	59	16	14	60	45	2	
	G 1	G 1/2	357-130-223	351-173	G 1	LH	83	200	42	22	25	36	108	3/4	272	28	59	16	14	60	45	2	
	G 1	G 1/2	357-130-235	351-173	M 35 x 1,5	RH	83	194	36	15	25	36	108	3/4	272	28	59	16	14	60	45	2	
	G 1	G 1/2	357-130-236	351-173	M 35 x 1,5	LH	83	194	36	15	25	36	108	3/4	272	28	59	16	14	60	45	2	
32	1 1/4 NPT	3/4 NPT	527-000-054	525-592	G 1 1/4	RH	91	234	54	28	31,8	46	119	1	285	35	72	22	20	60	58	2	
	1 1/4 NPT	3/4 NPT	527-000-055	525-592	G 1 1/4	LH	91	234	54	28	31,8	46	119	1	285	35	72	22	20	60	58	2	
	G 1 1/4	G 3/4	527-130-054	525-926	G 1 1/4	RH	91	234	54	28	31,8	46	119	1	285	35	72	22	20	60	58	2	
	G 1 1/4	G 3/4	527-130-055	525-926	G 1 1/4	LH	91	234	54	28	31,8	46	119	1	285	35	72	22	20	60	58	2	
40	1 1/2 NPT	3/4 NPT	557-000-198	451-162	G 1 1/2	RH	108	270	72	29	38	55	149	1 1/4	319	38	76	26	24	60	65	2	
	1 1/2 NPT	3/4 NPT	557-000-199	451-162	G 1 1/2	LH	108	270	72	29	38	55	149	1 1/4	319	38	76	26	24	60	65	2	
	G 1 1/2	G 3/4	557-130-198	451-175	G 1 1/2	RH	108	270	72	29	38	55	149	1 1/4	319	38	76	26	24	60	65	2	
	G 1 1/2	G 3/4	557-130-199	451-175	G 1 1/2	LH	108	270	72	29	38	55	149	1 1/4	319	38	76	26	24	60	65	2	
	G 1 1/2	G 3/4	557-130-200	451-175	M 50 x 1,5	RH	108	264	66	23	38	55	149	1 1/4	319	38	76	26	24	60	65	2	
	G 1 1/2	G 3/4	557-130-201	451-175	M 50 x 1,5	LH	108	264	66	23	38	55	149	1 1/4	319	38	76	26	24	60	65	2	
50	2 NPT	1 1/4 NPT	657-000-124	655-968	G 2	RH	118	312	65	29	47,6	60	165	1 1/4	382	45	96	34	31	60	70	2,5	
	2 NPT	1 1/4 NPT	657-000-125	655-968	G 2	LH	118	312	65	29	47,6	60	165	1 1/4	382	45	96	34	31	60	70	2,5	
	G 2	G 1 1/4	657-130-124	655-707	G 2	RH	118	312	65	29	47,6	60	165	1 1/4	382	45	96	34	31	60	70	2,5	
	G 2	G 1 1/4	657-130-125	655-707	G 2	LH	118	312	65	29	47,6	60	165	1 1/4	382	45	96	34	31	60	70	2,5	

DEUBLIN

Rotating Union for General Purposes, DN 65



Operating Data

Max. Water Pressure*	200 PSI	14 bar
Max. Sat. Steam Pressure (Interm.)	14 PSI	1 bar
Max. Speed	750 RPM	750 min ⁻¹
Torque at 120 PSI/8 bar	4 FT.LBS	5,4 Nm
Max. Temperature	120 °C	> 120 °C consult DEUBLIN

* Pressures exceeding 8 bars only permissible with cold water (50 °C max.)

- monoflow and duoflow design
- self-supported rotating union
- radial housing connection
- balanced mechanical seal:
Carbon Graphite/Ceramic - standard;
Tungsten Carbide/Ceramic - E.L.S. (Extended Life Sealing)
- 4 vent holes
- cast iron housing
- steel rotor
- special options:
nickel-plated design
threaded vent holes
- Lubrication Guide page 52

For further information please contact **DEUBLIN** or your local representative.

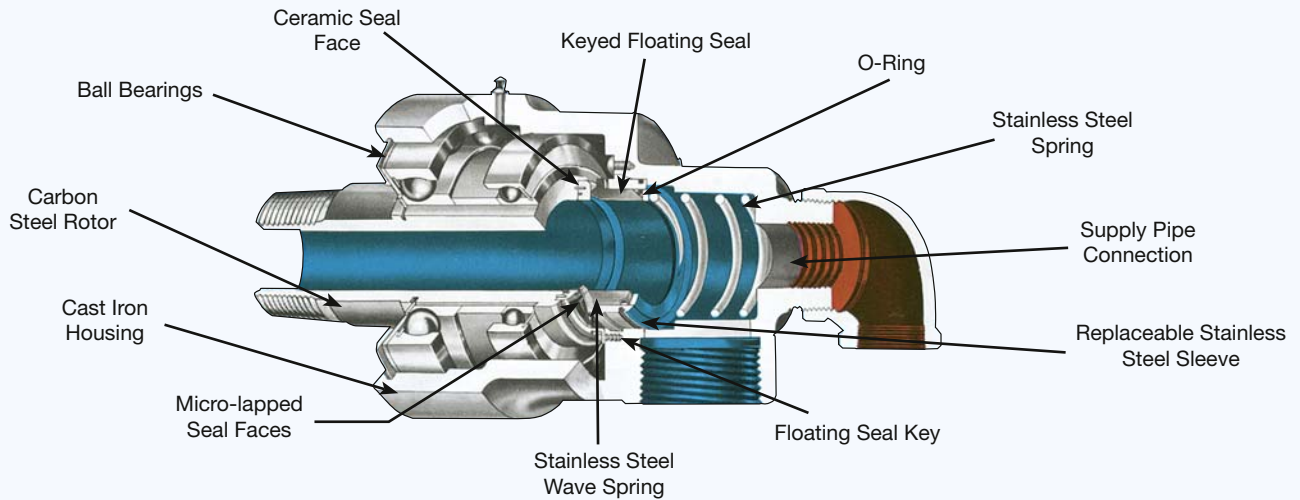

Duoflow Rotating Union for Threaded Supply Pipe

Duoflow Rotating Union for Rotating Supply Pipe

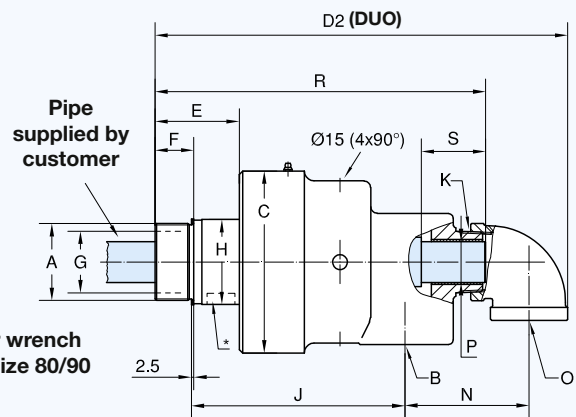
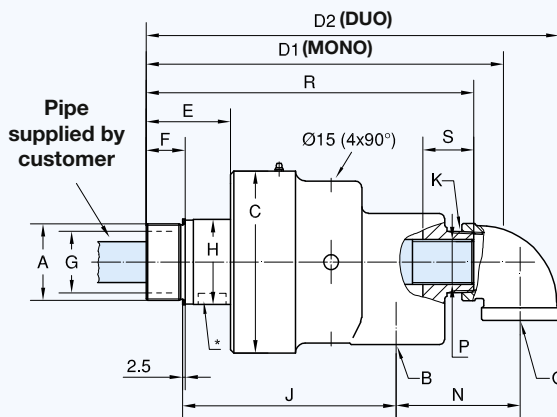

*) Slot for spanner wrench as per DIN 1810, size 80/90

DN	B NPT	O NPT	Ordering No.		A Rotor Connections	C ø	D1	D2	E	F	G ø	H ø	J	K NPT	N	P Pipe	R	S	kg
			STD	E.L.S.															
65	2 1/2	1 1/4	755-700-330-117+	755-701-330-117+	G 2 1/2 RH	178	336	381	82	38	60,3	83	208	2	108	1 NPT	308	13	20
	2 1/2	1 1/4	755-700-411-117+	755-701-411-117+	G 2 1/2 LH	178	336	381	82	38	60,3	83	208	2	108	1 NPT	308	13	20
	2 1/2	1 1/2	755-707-330-139+	755-731-330-139+	G 2 1/2 RH	178	336	391	82	38	60,3	83	208	2	112	G 1 1/2	320	45	20
	2 1/2	1 1/2	755-707-411-139+	755-731-411-139+	G 2 1/2 LH	178	336	391	82	38	60,3	83	208	2	112	G 1 1/2	320	45	20
	2 1/2	1 1/2	755-732-330-139+	755-733-330-139+	G 2 1/2 RH	178	-	391	82	38	60,3	83	208	2	112	ø 39,9 h 13	328	70	20
	2 1/2	1 1/2	755-732-411-139+	755-733-411-139+	G 2 1/2 LH	178	-	391	82	38	60,3	83	208	2	112	ø 39,9 h 13	328	70	20

+ For Monoflow design omit -117 or -139 suffix

DEUBLIN

Rotating Union with Flange Rotor, DN 40, 50 and 65

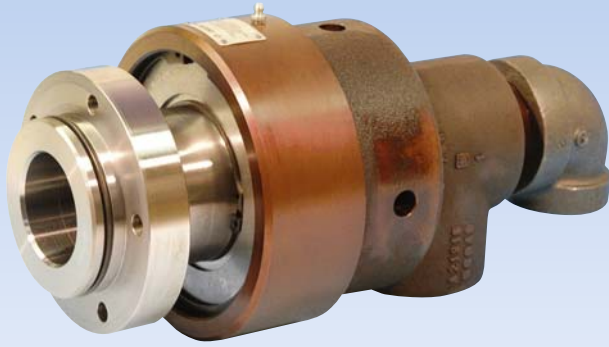

- monoflow and duoflow design
- self-supported rotating union
- radial housing connection
- balanced mechanical seal
Carbon Graphite/Bronze or
Carbon Graphite/Ceramic - standard;
Tungsten Carbide/Ceramic - E.L.S. (Extended Life Sealing)
- 3 or 4 vent holes
- forged brass housing (DN 40 and 50) and cast iron housing (DN 65)
- steel rotor
- Lubrication Guide page 52

Operating Data

Max. Water Pressure*	Model 555	730 PSI	50 bar
	655,755	200 PSI	14 bar
Max. Satur. Steam Pressure (Interm.)		14 PSI	1 bar
Max. Speed	Model 555	1,500 RPM	1.500 min ⁻¹
	655-755	1,000 RPM	1.000 min ⁻¹
Max. Temperature	120 °C	> 120 °C consult DEUBLIN	

* Pressures exceeding 8 bars only permissible with cold water (50 °C max.)

For further information please contact **DEUBLIN** or your local representative.

Monoflow Rotating Unions

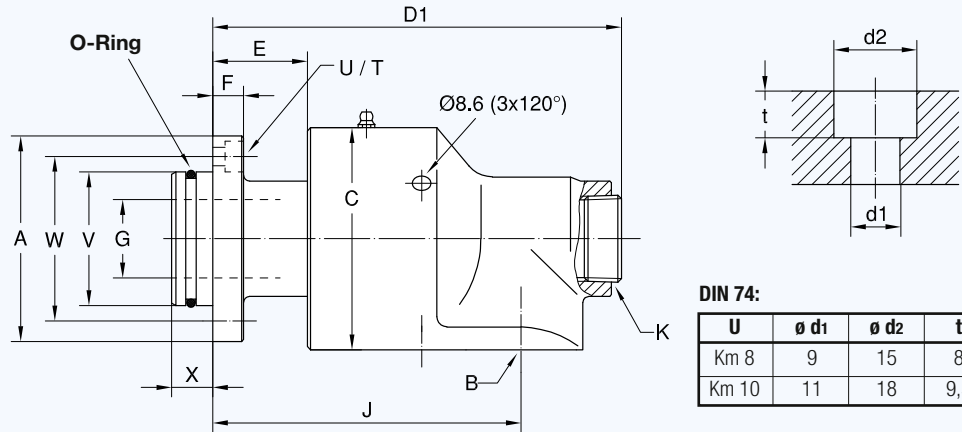

Flange O-Ring

(supplied by **DEUBLIN**) for:
Model O-Ring Size
555 58 x 4 Viton
655 73 x 4 Viton

DIN 74:

U	ø d1	ø d2	t
Km 8	9	15	8
Km 10	11	18	9,5

DN	B	Ordering No.	A ø	C ø	D1	E	F	G ø	J	K NPT	T	U DIN 74	V _{f7} ø PT	W ø	X	kg
40	G 1 1/2	555-385-765	100	108	202	46	15	38	150	1 1/4	5 x 72°	Km 8	65	80	20	7,3
50	G 2	655-527-421	125	118	229	46	15,5	47,6	172	1 1/4	5 x 72°	Km 10	80	100	20	8,8

Monoflow Rotating Unions

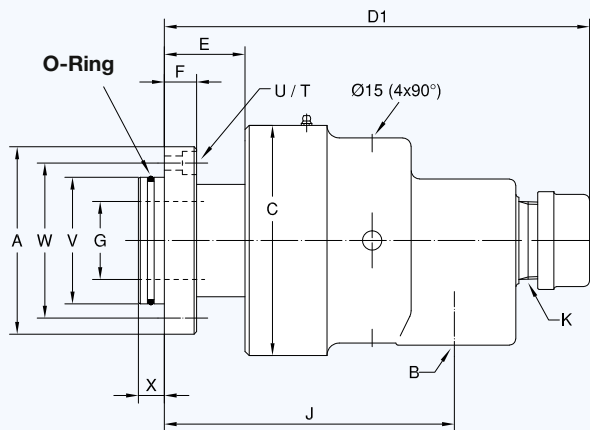

Flange O-Ring

(supplied by **DEUBLIN**) for:
Modell O-Ring Size
755 90 x 4 Viton

DN	B NPT	Ordering Nr.		A ø	C ø	D1	E	F	G ø	J	K NPT	T	U DIN 74	V _{f7} ø PT	W ø	X	kg
		STD	E.L.S.														
65	2 1/2	755-713-495	755-726-495	145	178	317	63	26	60,3	225	2	5 x 72°	Km 10	98	120	20	22

Duoflow Rotating Union for Threaded Supply Pipe

Duoflow Rotating Union for Rotating Supply Pipe

Flange O-Ring
(supplied by DEUBLIN) for:
Model O-Ring Size
555 58 x 4 Viton
655 73 x 4 Viton

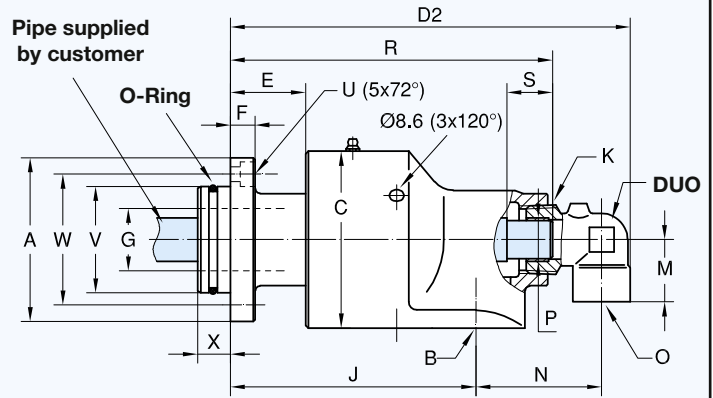
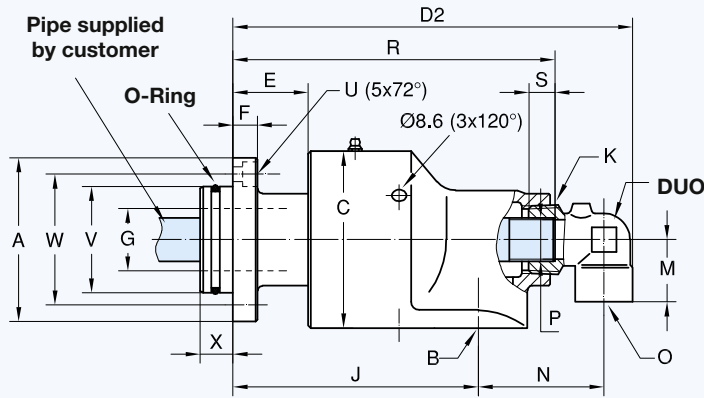

DN	B	O	Ordering No.	DUO	A ø	C ø	D2	E	F	G ø	J	K NPT	M	N	P Pipe	R	S	U** DIN 74	V _{f7} øPT	W ø	X	kg
40	G 1 1/2	G 3/4	555-385-765	451-171	100	108	244	46	15	38	150	1 1/4	38	76	G 3/4	196	16	Km 8	65	80	20	7,6
	G 1 1/2	G 3/4	555-385-765	451-173	100	108	244	46	15	38	150	1 1/4	38	76	ø 25,8 h 13	212	44	Km 8	65	80	20	7,6
50	G 2	G 3/4	655-527-421	451-171	125	118	271	46	15,5	47,6	172	1 1/4	38	82	G 3/4	223	16	Km 10	80	100	20	9
	G 2	G 3/4	655-527-421	451-173	125	118	271	46	15,5	47,6	172	1 1/4	38	82	ø 25,8 h 13	238	44	Km 10	80	100	20	9
	G 2	G 1 1/4	655-527-421	450-534	125	118	293	46	15,5	47,6	172	1 1/4	45	96	G 1	233	26	Km 10	80	100	20	9,1
	G 2	G 1 1/4	655-527-421	450-612	125	118	293	46	15,5	47,6	172	1 1/4	45	96	ø 32,1 h 13	234	50	Km 10	80	100	20	9,1

Duoflow Rotating Union for Threaded Supply Pipe

Duoflow Rotating Union for Rotating Supply Pipe

Flange O-Ring
(supplied by DEUBLIN) for:
Model O-Ring Size
755 90 x 4 Viton

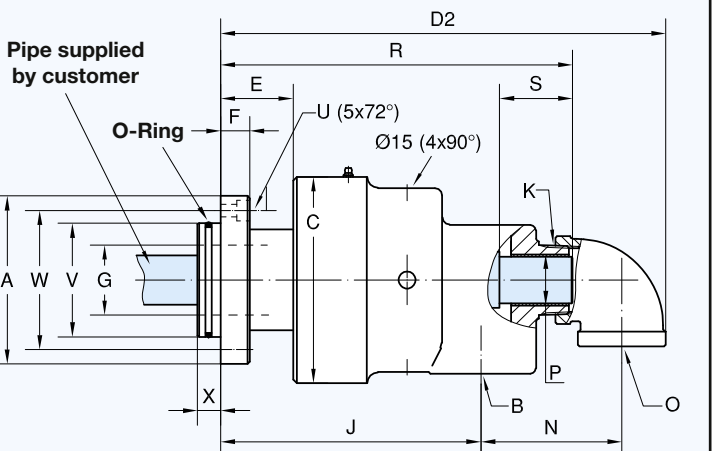
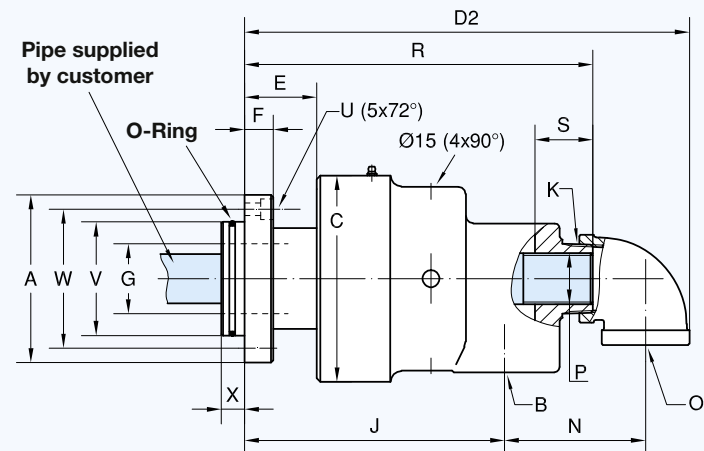

DN	B NPT	O NPT	Ordering No.		A ø	C ø	D2	E	F	G ø	J	K NPT	N	P Pipe	R	S	U** DIN 74	V _{f7} øPT	W ø	X	kg
			STD	E.L.S.																	
65	2 1/2	1 1/4	755-727-495-117	755-728-495-117	145	178	372	63	26	60,3	225	2	109	1 NPT	288	13	Km 10	98	120	20	23
	2 1/2	1 1/2	755-713-495-139	755-726-495-139	145	178	372	63	26	60,3	225	2	112	G 1 1/2	301	45	Km 10	98	120	20	23
	2 1/2	1 1/2	755-729-495-139	755-730-495-139	145	178	372	63	26	60,3	225	2	112	ø 39,9 h 13	308	70	Km 10	98	120	20	23

** See page 14, DIN 74 table

DEUBLIN

Rotating Union 57 Series for Water Service, DN 80

- monoflow and duoflow design
- self-supported rotating union
- radial housing connection
- balanced mechanical seal
Carbon Graphite/Tungsten Carbide
- full-media flow
- easy and quick replacement of sealing components
(rotor seal, floating seal)
- vent holes
- cast iron housing
- steel rotor
- Lubrication Guide page 52

For further information please contact **DEUBLIN** or your local representative.

Operating Data

Max. Water Pressure	150 PSI	10 bar
Max. Satur. Steam Pressure (Interm.)	14 PSI	1 bar
Max. Speed	500 RPM	500 min ⁻¹
Torque 150 PSI/10 bar	6 FT.LBS	8,2 Nm
Max. Temperature	120 °C	> 120 °C consult DEUBLIN

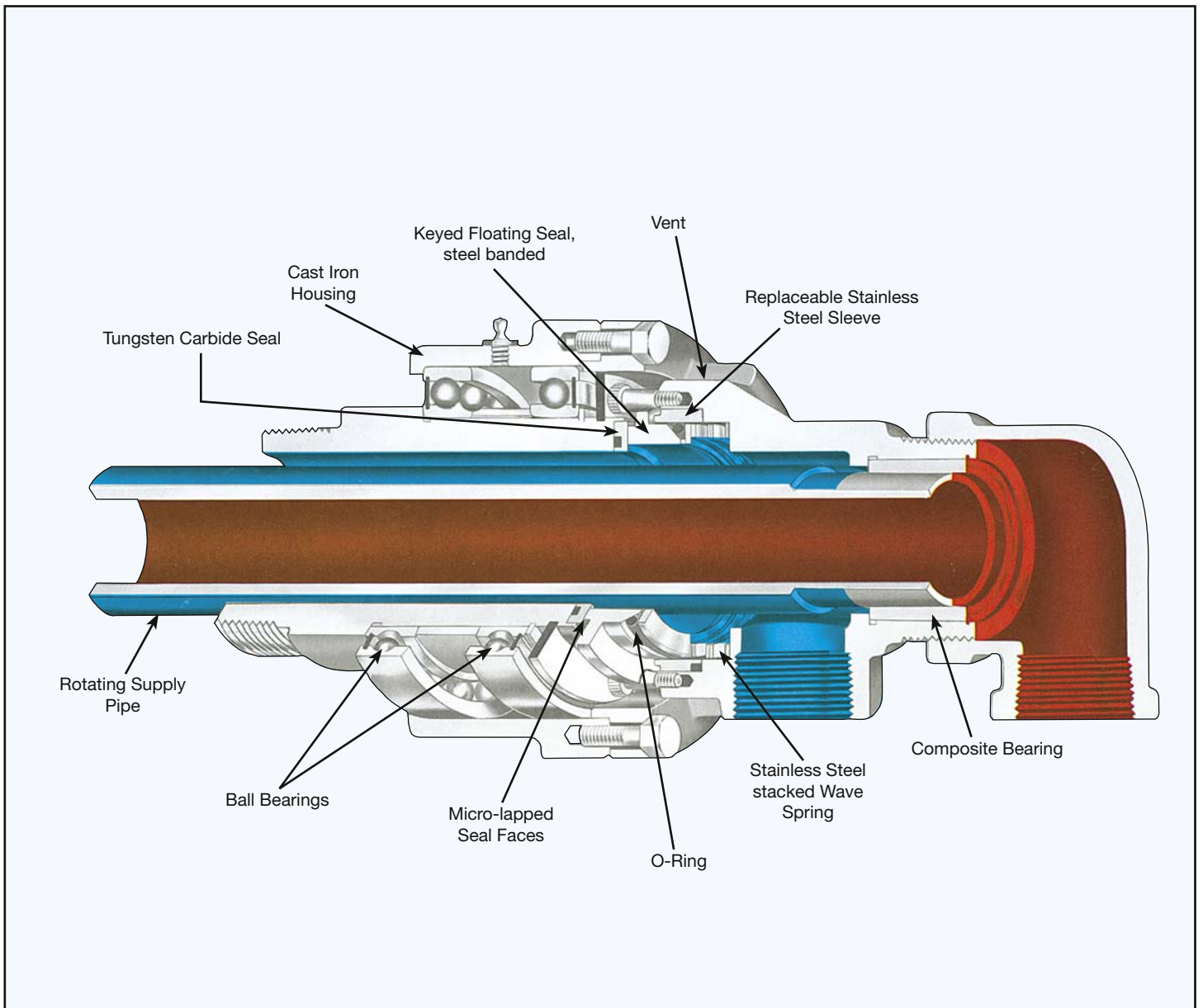

Monoflow Rotating Union

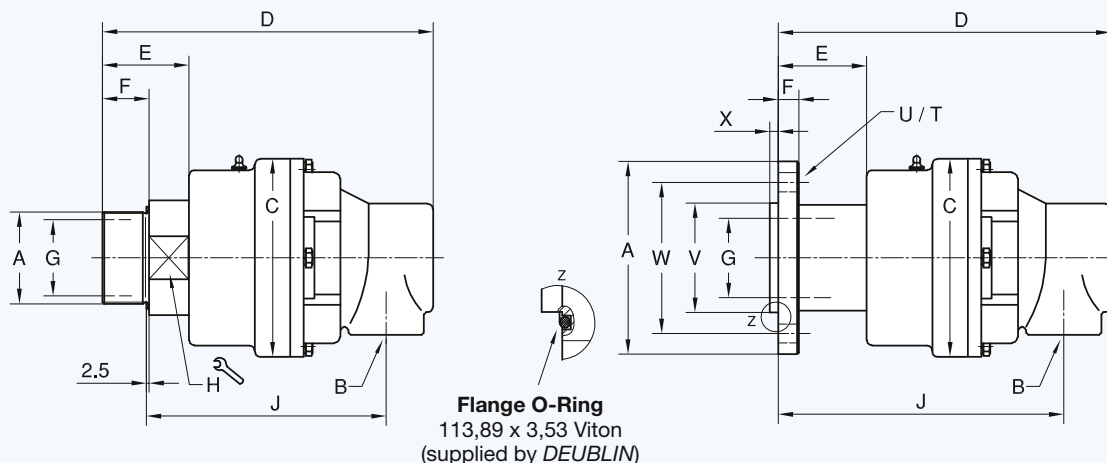

Duoflow Rotating Union for Threaded Supply Pipe

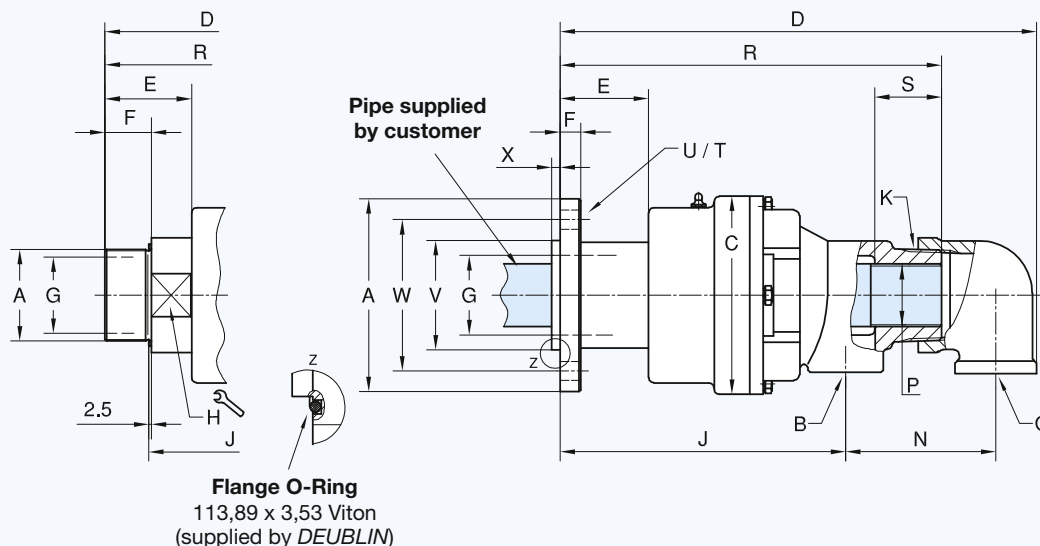

Rotating Supply Pipe Design

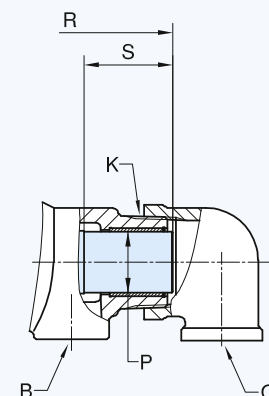

Monoflow Rotating Union

DN	B NPT	Ordering No.	A Rotor Connections		C ∅	D	E	F	G ∅	H ⌀	J	T	U ∅	V ∅PT	W ∅	X	kg
80	3	857-000-118	G 3	RH	190	345	84	45	73	102	247	-	-	-	-	-	23
	3	857-000-119	G 3	LH	190	345	84	45	73	102	247	-	-	-	-	-	23
	3	857-000-145	Flange ∅ 185		190	346	85	20	73	-	291	4 x 90°	18	105,00 104,95	145	8	27

Duoflow Rotating Union

DN	B + O NPT	Ordering No.	A Rotor Connections		C ∅	D	E	F	G ∅	H ⌀	J	K NPT	N	P	R	S	T	U ∅	V ∅PT	W ∅	X	kg
80	2 x 2	857-011-118	G 3	RH	190	453	84	45	73	102	228	3	144	G 2	362	28	-	-	-	-	-	25
	2 x 2	857-011-119	G 3	LH	190	453	84	45	73	102	228	3	144	G 2	362	28	-	-	-	-	-	25
	2 x 2	857-011-145	Flange ∅ 185		190	454	85	20	73	-	271	3	144	G 2	363	28	4 x 90°	18	105,00 104,95	145	8	29
	2 x 2	857-002-118	G 3	RH	190	453	84	45	73	102	228	3	144	58,7 h13	364	85	-	-	-	-	-	25
	2 x 2	857-002-119	G 3	LH	190	453	84	45	73	102	228	3	144	58,7 h13	364	85	-	-	-	-	-	25
	2 x 2	857-002-145	Flange ∅ 185		190	454	85	20	73	-	271	3	144	58,7 h13	365	85	4 x 90°	18	105,00 104,95	145	8	29

DEUBLIN

Rotating Union 6000 Series for Water Service, DN 50 - 100



- monoflow and duoflow design
- self-supported rotating union
- radial housing connection
- balanced mechanical seal
Carbon Graphite/ Tungsten Carbide - standard and Silicon Carbide/Tungsten Carbide - E.L.S. (Extended Life Sealing)
- steel banded floating seal
- easy and quick replacement of sealing components (rotor seal, floating seal)
- full-media flow
- vent slots
- cast iron housing
- steel rotor
- Lubrication Guide page 52

Operating Data

Max. Water Pressure		150 PSI	10 bar
Max. Speed		750 RPM	750 min ⁻¹
Torque for	Model 6200	4 FT.LBS	5,4 Nm
	6250	7 FT.LBS	9,5 Nm
	6300	8 FT.LBS	10,9 Nm
	6400	10 FT.LBS	13,6 Nm
Max. Temperature		120 °C	> 120 °C consult DEUBLIN

For applications above 120 °C please ask for information covering the new HT-series.

For further information please contact **DEUBLIN** or your local representative.

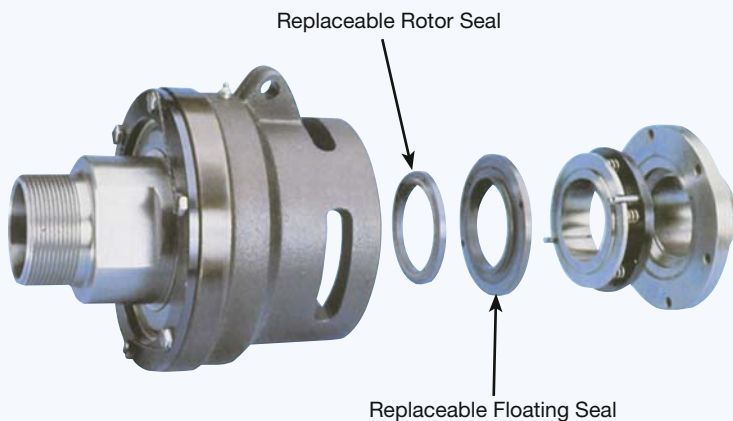
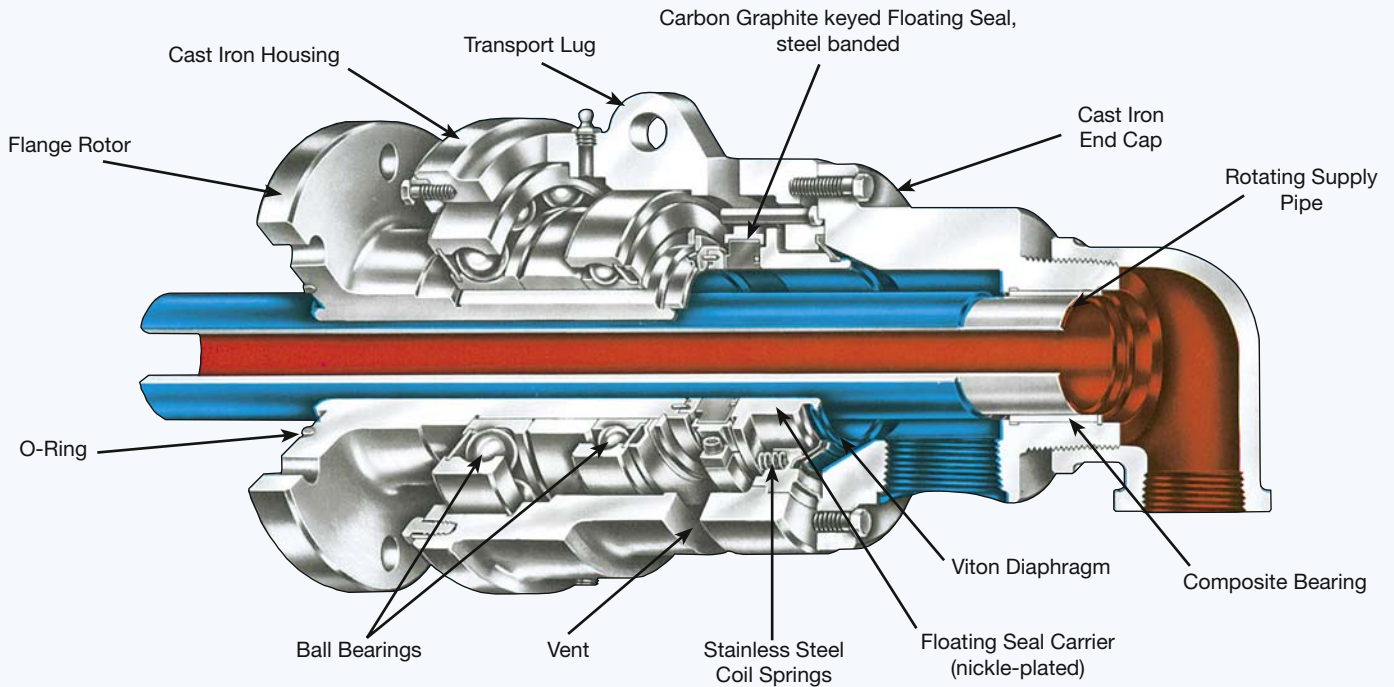

DEUBLIN Exclusive On-The-Machine Repair Cartridge

Seals are replaced quickly and easily. There's no need to remove hose connections or use special tools.

Make sure the system is cold and pressureless! Simply remove 6 hex bolts and end cap then remove floating seal cartridge and rotor seal face and replace with new seals.

Rotor seal is keyed and sealed to the rotor with a built-in O-Ring.

Replace end cap, hex bolts and safety wire. Detailed instructions available from **DEUBLIN**.

Monoflow Rotating Union

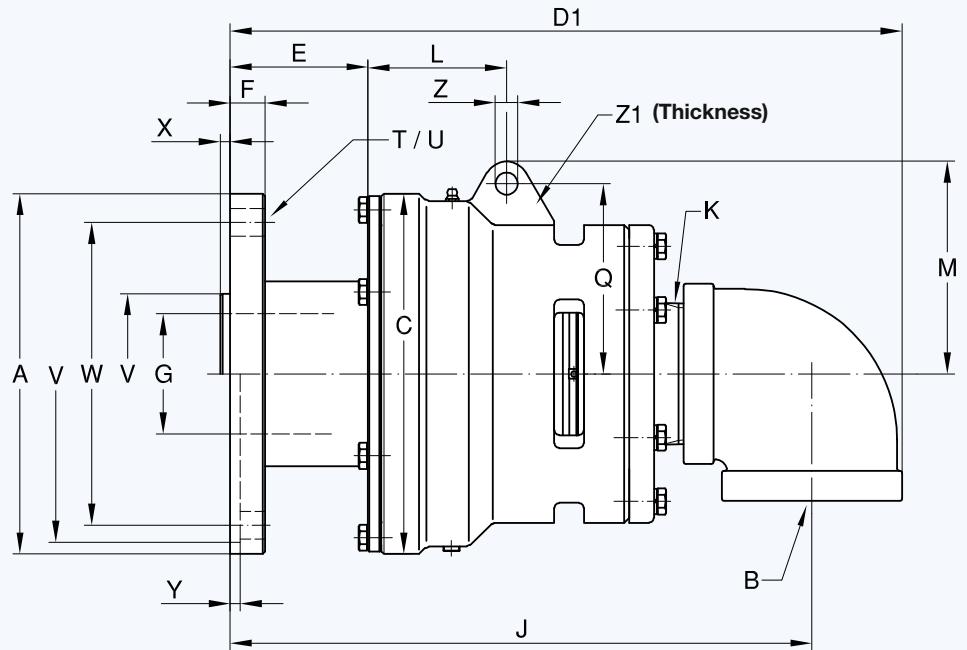
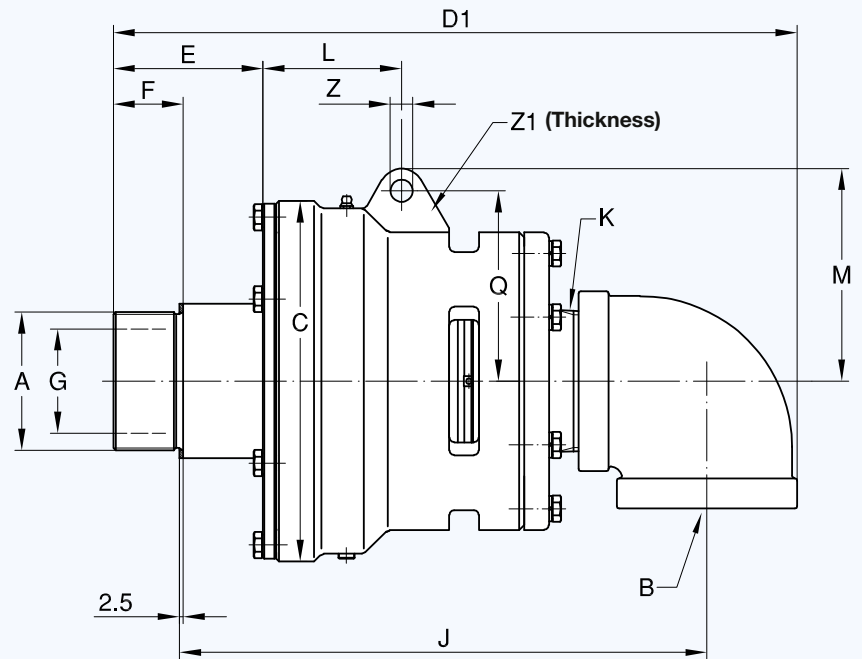

Flange O-Ring

(supplied by DEUBLIN) for:
 Model O-Ring Size
 6200 94,6 x 5,33 Viton
 6250 94,6 x 5,33 Viton
 6300 126,4 x 5,33 Viton
 6400 151,8 x 5,33 Viton

DN	B NPT	Ordering No.		A Rotor Connections	C ø	D1	E	F	G ø	J	K NPT	L	M	Q	T	U ø	V ø PT	W ø	X	Y	Z ø	Z1	kg
		STD	E.L.S.																				
50	2	6200-001-137	6200-016-137	G 2 RH	133	292	66	29	47,6	228	2	73	90	78	-	-	-	-	-	-	12,7	25,4	9,5
	2	6200-001-139	6200-016-139	G 2 LH	133	292	66	29	47,6	228	2	73	90	78	-	-	-	-	-	-	12,7	25,4	9,5
	2	6200-001-115	6200-016-115	Flange ø 228,6	133	308	82	25,4	47,6	270	2	73	90	78	4 x 90°	17,5	211,25 211,20	162	-	6,4	12,7	25,4	16,5
65	2 1/2	6250-001-121	6250-018-121	G 2 1/2 RH	178	367	84	38	60,3	283	2 1/2	95	113	98	-	-	-	-	-	-	14,3	25,4	23
	2 1/2	6250-001-123	6250-018-123	G 2 1/2 LH	178	367	84	38	60,3	283	2 1/2	95	113	98	-	-	-	-	-	-	14,3	25,4	23
	2 1/2	6250-001-300	6250-018-300	Flange ø 228,6	178	373	90	25,4	60,3	325	2 1/2	95	113	98	4 x 90°	17,5	211,25 211,20	162	-	6,4	14,3	25,4	27,7
80	3	6300-001-161	6300-015-161	G 3 RH	229	432	96	45	73	336	3	87	135	121	-	-	-	-	-	-	14,3	25,4	45,5
	3	6300-001-162	6300-015-162	G 3 LH	229	432	96	45	73	336	3	87	135	121	-	-	-	-	-	-	14,3	25,4	45,5
	3	6300-001-103	6300-015-103	Flange ø 228,6	229	424	88	22,2	76,2	370	3	87	135	121	6 x 60°	17,5	101,70 101,65	192	6,4	-	14,3	25,4	52
100	4	6400-030-330	6400-042-330	Flange ø 276	280	483	78	22,2	101,6	411	4	94	156	133	6 x 60°	20,6	120,62 120,55	228,6	7,5	-	16	32	77

Duoflow Rotating Unions for Threaded Supply Pipe

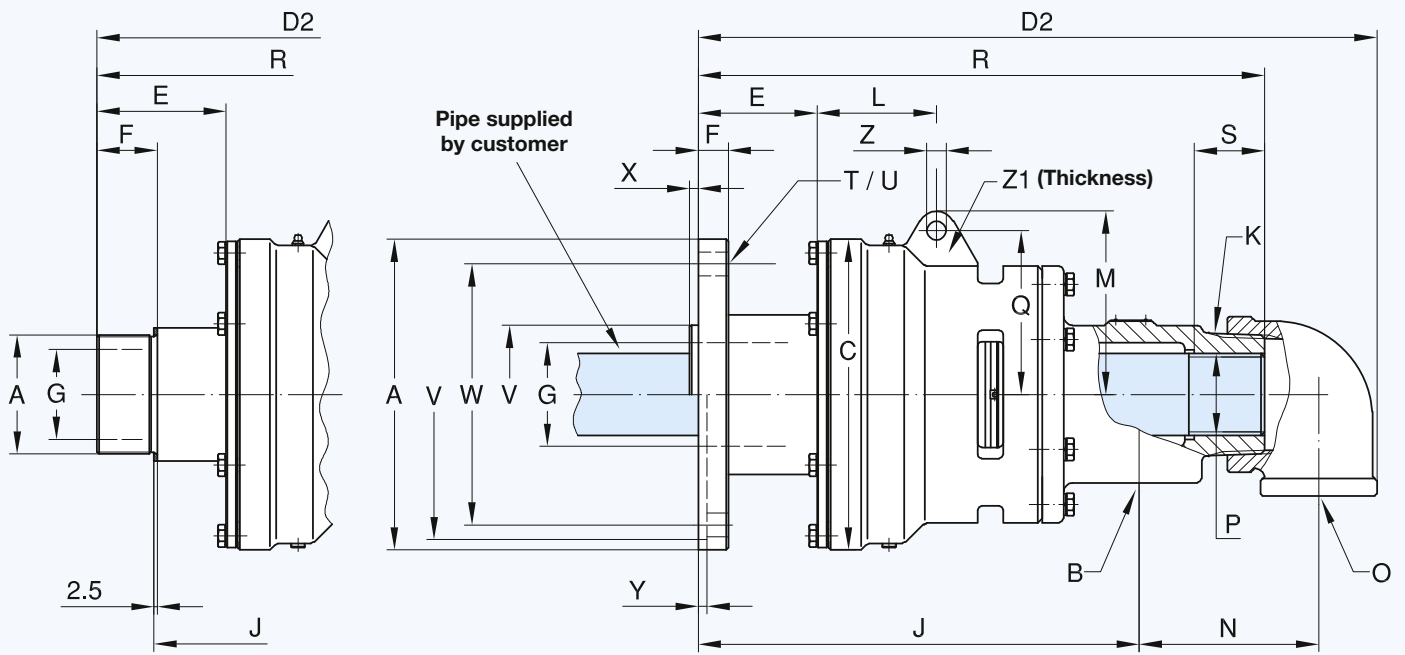

Duoflow Rotating Union for Threaded Supply Pipe

DN	B + 0 NPT	Ordering No.		A		C ∅	D ₂	E	F	G ∅	J	K NPT
		STD	E.L.S.	Rotor Connections								
50	2 x 1	6200-013-137	6200-020-137	G 2	RH	133	321	66	29	47,6	181	2
	2 x 1	6200-013-139	6200-020-139	G 2	LH	133	321	66	29	47,6	181	2
	2 x 1	6200-013-115	6200-020-115	Flange ∅ 228,6		133	337	82	25,4	47,6	223	2
65	2 x 1 1/2	6250-025-121	6250-035-121	G 2 1/2	RH	178	412	84	38	60,3	233	2 1/2
	2 x 1 1/2	6250-025-123	6250-035-123	G 2 1/2	LH	178	412	84	38	60,3	233	2 1/2
	2 x 1 1/2	6250-025-300	6250-035-300	Flange ∅ 228,6		178	420	90	25,4	60,3	275	2 1/2
80	2 x 2	6300-025-161	6300-035-161	G 3	RH	229	507	96	45	73	289	3
	2 x 2	6300-025-162	6300-035-162	G 3	LH	229	507	96	45	73	289	3
	2 x 2	6300-025-103	6300-035-103	Flange ∅ 228,6		229	499	88	22,2	76,2	324	3
100	2 x 2 1/2	6400-053-330	6400-055-330	Flange ∅ 276		280	549	78	22,2	101,6	351	4

Duoflow Rotating Union for Rotating Supply Pipe

DN	B + 0 NPT	Ordering No.		A		C ∅	D ₂	E	F	G ∅	J	K NPT
		STD	E.L.S.	Rotor Connections								
50	2 x 1	6200-002-137	6200-030-137	G 2	RH	133	321	66	29	47,6	181	2
	2 x 1	6200-002-139	6200-030-139	G 2	LH	133	321	66	29	47,6	181	2
	2 x 1	6200-002-115	6200-030-115	Flange ∅ 228,6		133	337	82	25,4	47,6	223	2
65	2 x 1 1/2	6250-002-121	6250-030-121	G 2 1/2	RH	178	412	84	38	60,3	233	2 1/2
	2 x 1 1/2	6250-002-123	6250-030-123	G 2 1/2	LH	178	412	84	38	60,3	233	2 1/2
	2 x 1 1/2	6250-002-300	6250-030-300	Flange ∅ 228,6		178	420	90	25,4	60,3	275	2 1/2
80	2 x 2	6300-002-161	6300-030-161	G 3	RH	229	507	96	45	73	289	3
	2 x 2	6300-002-162	6300-030-162	G 3	LH	229	507	96	45	73	289	3
	2 x 2	6300-002-103	6300-030-103	Flange ∅ 228,6		229	499	88	22,2	76,2	324	3
100	2 x 2 1/2	6400-040-330	6400-052-330	Flange ∅ 276		280	549	78	22,2	101,6	351	4

Duoflow Rotating Unions for Rotating Supply Pipe

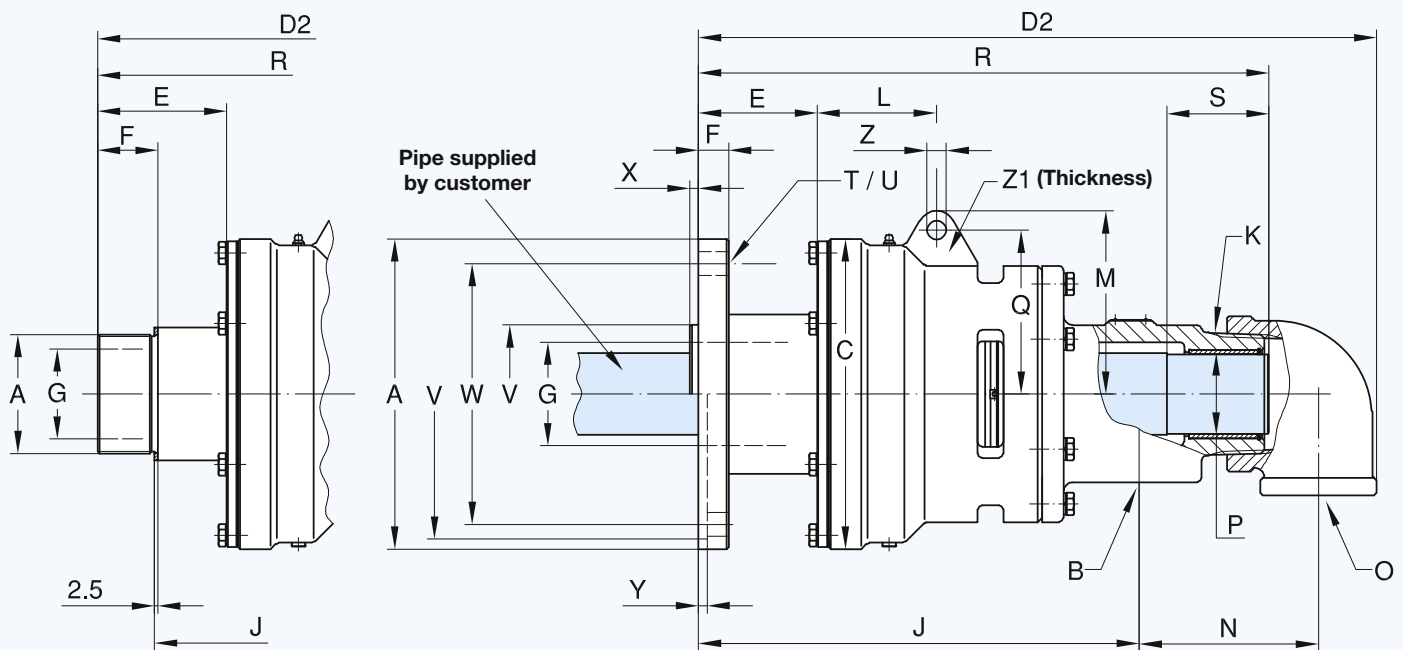

L	M	N	P Pipe	Q	R	S	T	U ∅	V ∅ PT	W ∅	X	Y	Z ∅	Z ₁	kg	DN
73	90	95	G 1	78	267	25	-	-	-	-	-	-	12,7	25,4	13,2	50
73	90	95	G 1	78	267	25	-	-	-	-	-	-	12,7	25,4	13,2	
73	90	95	G 1	78	284	25	4 x 90°	17,5	211,25 211,20	162	-	6,4	12,7	25,4	18,2	
95	113	103	G 1 1/2	98	346	25	-	-	-	-	-	-	14,3	25,4	25,2	65
95	113	103	G 1 1/2	98	346	25	-	-	-	-	-	-	14,3	25,4	25,2	
95	113	103	G 1 1/2	98	352	25	4 x 90°	17,5	211,25 211,20	162	-	6,4	14,3	25,4	31,8	
87	135	135	G 2	121	424	28	-	-	-	-	-	-	14,3	25,4	47,7	80
87	135	135	G 2	121	424	28	-	-	-	-	-	-	14,3	25,4	47,7	
87	135	135	G 2	121	416	28	6 x 60°	17,5	101,70 101,65	192	6,4	-	14,3	25,4	55	
94	156	146	G 2 1/2	133	446	40	6 x 60°	20,6	120,62 120,55	228,6	7,6	-	16	32	77	100

L	M	N	P Pipe ∅ h13	Q	R	S	T	U ∅	V ∅ PT	W ∅	X	Y	Z ∅	Z ₁	kg	DN
73	90	95	31,6	78	267	48	-	-	-	-	-	-	12,7	25,4	13,2	50
73	90	95	31,6	78	267	48	-	-	-	-	-	-	12,7	25,4	13,2	
73	90	95	31,6	78	284	48	4 x 90°	17,5	211,25 211,20	162	-	6,4	12,7	25,4	18,2	
95	113	103	47,6	98	346	54	-	-	-	-	-	-	14,3	25,4	25,2	65
95	113	103	47,6	98	346	54	-	-	-	-	-	-	14,3	25,4	25,2	
95	113	103	47,6	98	352	54	4 x 90°	17,5	211,25 211,20	162	-	6,4	14,3	25,4	31,8	
87	135	135	58,7	121	424	75	-	-	-	-	-	-	14,3	25,4	47,7	80
87	135	135	58,7	121	424	75	-	-	-	-	-	-	14,3	25,4	47,7	
87	135	135	58,7	121	416	75	6 x 60°	17,5	101,70 101,65	192	6,4	-	14,3	25,4	55	
94	156	146	74,8	133	450	100	6 x 60°	20,6	120,62 120,55	228,6	7,6	-	16	32	77	100

DEUBLIN

Rotating Union F Series for Water Service, DN 125



- monoflow and duoflow design
- self-supported rotating union
- balanced mechanical seal:
Carbon Graphite/Tungsten Carbide
- two widely spaced ball bearings
- labyrinth seal protects bearings
- nickel-plated cast iron housing
- high corrosion resistant
- steel flange rotor
- on-the-machine seal replacement capability
- inlet/outlet flange:
standard DIN,
optional ANSI, JIS
- special designs up to **DN 300** upon request

Operating Data

Max. Water Pressure*	150 PSI	10 bar
Max. Speed*	750 RPM	750 min ⁻¹
Max. Temperature	120 °C	> 120 °C consult DEUBLIN

* Operation at max. pressure combined with max. speed is not permissible
If operating conditions are marginal, please consult our Engineering Department

For further information please contact **DEUBLIN** or your local representative.

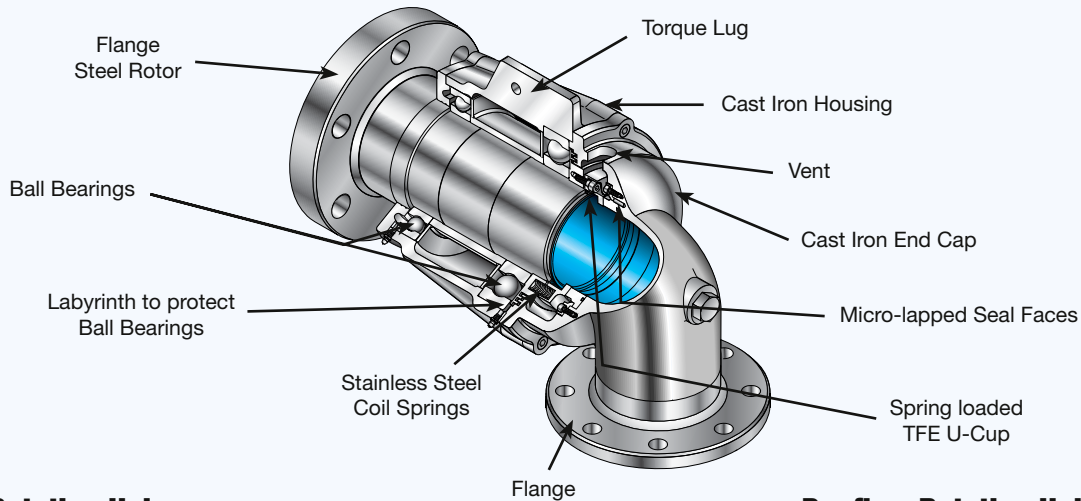

Monoflow Rotating Union

Duoflow Rotating Union

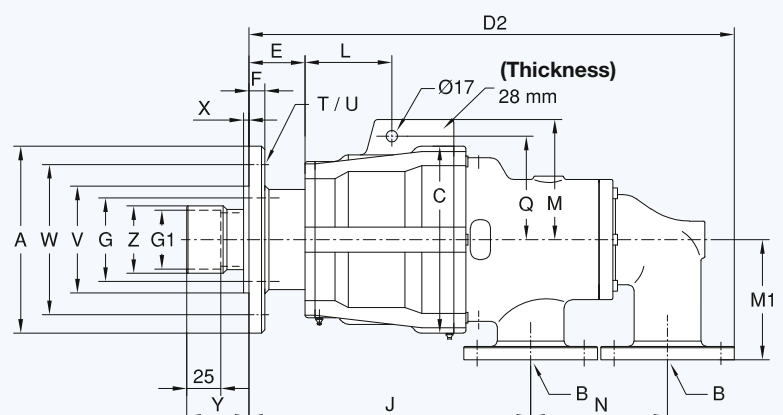
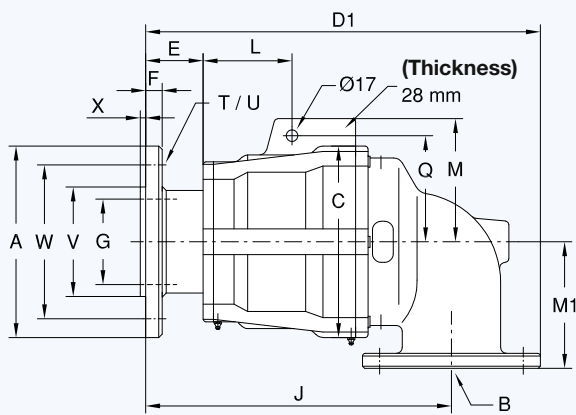

Monoflow Rotating Union

DN	B Flange	Ordering No.	A Ø	C Ø	D1	E	F	G Ø	J	L	M	M ₁	Q	T	U Ø	V Ø PT 18	W Ø	X	kg
125	DN 125	F127-004-200	280	280	577	84	25	125	447	130	180	185	155	6 x 60°	18	160	225	8	100

Duoflow Rotating Union

DN	B Flange	Ordering No.	A Ø	C Ø	D2	E	F	G Ø	G ₁ Ø	J	L	M	M ₁	N	Q	T	U Ø	V Ø PT 18	W Ø	X	Y	Z Ø	kg
125	2 x DN 80	F127-005-204-701	280	280	727	84	25	125	88,3 +0,1	422	130	180	180	205	155	6 x 60°	18	160	255	8	93	101	120

DEUBLIN

Rotating Union 54 Series

Stainless Steel, DN 10 - 40

- monoflow and duoflow design
- self-supported rotating union
- radial or axial housing connection
- media contacting parts made of stainless steel (from 1.4571)
- full-media flow
- available for use in potentially explosive atmosphere defined by „ATEX

For further information please contact **DEUBLIN** or your local representative.



Operating Data

Max. Pressure and max. Speed see Diagram

Max. Temperature 71 °C > 71 °C consult **DEUBLIN**

Temperature > 71°C - max. 90 °C only if max. pressure ≤ 10 bar (150 PSI)

At temperatures > 71 °C (160 °F) media must be liquid (not vaporous)

Seals are Tungsten Carbide/Ceramic

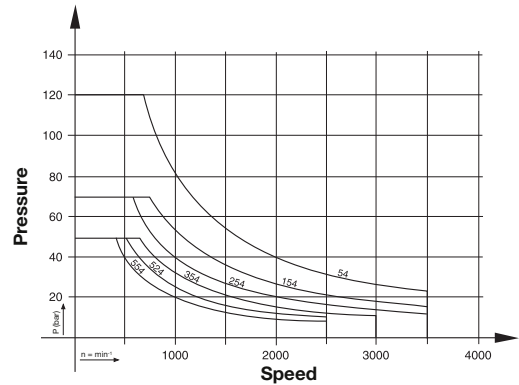

Monoflow Rotating Union with Radial Thread

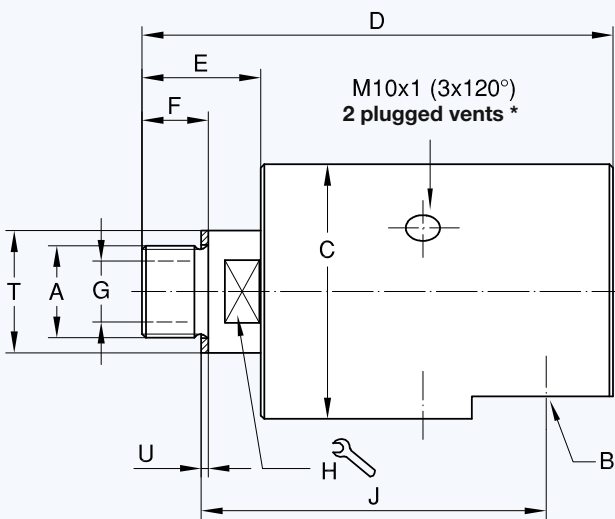

Monoflow Rotating Union with Axial Thread

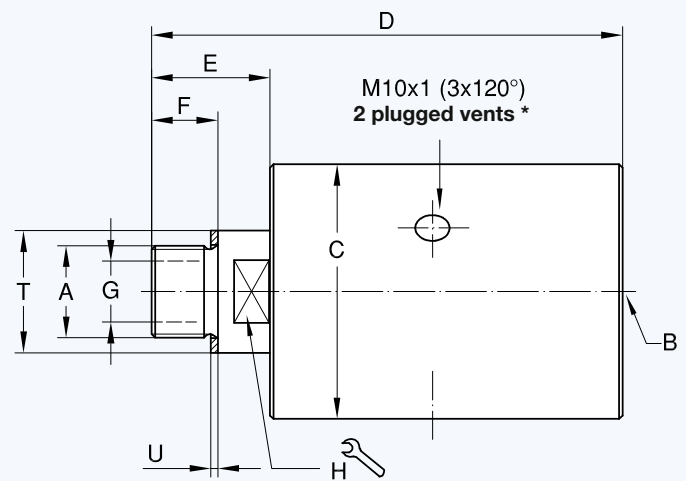

* Adjust open vent downwards, or change one plug respectively

Monoflow Rotating Union

DN	B G	Ordering No.		A Rotor Connections	C ∅	D	E	F	G ∅	H ∅	J	T ∅ h11	U	kg
		Radial	Axial											
10	G 3/8	54-000-110	54-010-110	G 3/8 RH	49	101	26	16	9,5	19	71,5	22	1,5	1,1
	G 3/8	54-000-111	54-010-111	G 3/8 LH	49	101	26	16	9,5	19	71,5	22	1,5	1,1
15	G 1/2	154-000-110	154-010-110	G 1/2 RH	64	123	34	19	12,7	24	89	30	1,5	1,8
	G 1/2	154-000-111	154-010-111	G 1/2 LH	64	123	34	19	12,7	24	89	30	1,5	1,8
20	G 3/4	254-000-110	254-010-110	G 3/4 RH	73	137	36	19	17,5	30	100	35	2	2,6
	G 3/4	254-000-111	254-010-111	G 3/4 LH	73	137	36	19	17,5	30	100	35	2	2,6
25	G 1	354-000-110	354-010-110	G 1 RH	94	161	43	22	25	36	117	45	2	5,1
	G 1	354-000-111	354-010-111	G 1 LH	94	161	43	22	25	36	117	45	2	5,1
32	G 1 1/4	524-000-110	524-010-110	G 1 1/4 RH	99	182	54	27	31,8	41	127	50	2	6
	G 1 1/4	524-000-111	524-010-111	G 1 1/4 LH	99	182	54	27	31,8	41	127	50	2	6
40	G 1 1/2	554-000-110	554-010-110	G 1 1/2 RH	108	200	58	29	38	50	138	60	2	8,2
	G 1 1/2	554-000-111	554-010-111	G 1 1/2 LH	108	200	58	29	38	50	138	60	2	8,2

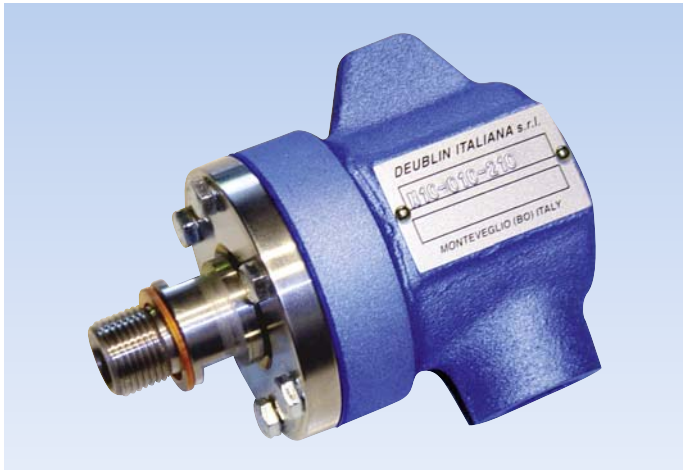

DEUBLIN

Rotating Union N Series

for Steam or Hot Oil Service, DN 10 and 15

- monoflow design: N10
- monoflow and duoflow design: N12
- self-supported rotating union
- large carbon graphite bearing
- pressurised spherical carbon graphite seal
- cast iron housing
- stainless steel rotor

For further information please contact **DEUBLIN** or your local representative.

Operating Data

Max. Saturated Steam Pressure*	250 PSI	17 bar
Max. Temperature	400 °F	200 °C
Max. Hot Oil Pressure*	100 PSI	7 bar
Max. Speed*	750 RPM	750 min ⁻¹

Max. Temperature 230 °C > 230 °C consult **DEUBLIN**

* Operation at max. pressure combined with max. speed is not permissible

Monoflow Rotating Union

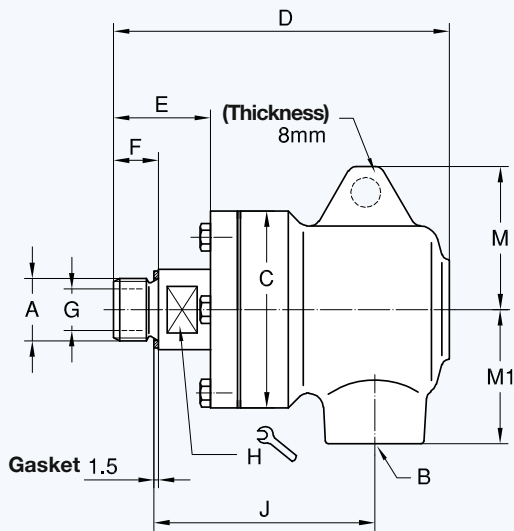

Duoflow Rotating Union

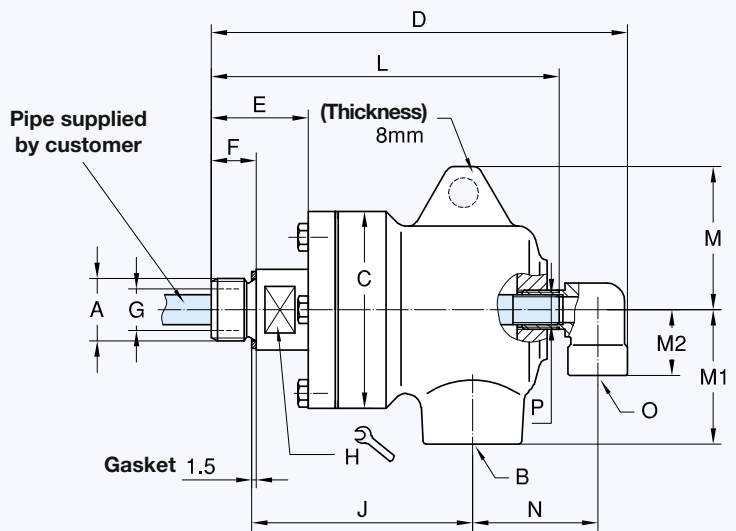

Monoflow Rotating Union

DN	B NPT	Ordering No.		A Rotor Connections	C ∅	D	E	F*	G ∅	H ⌀	J	M	M1	kg
		Steam	Hot Oil											
10	3/8	N10-020-210	N10-021-210	G 3/8 RH	60	105	31	15	10	17	68,5	42	40	1,1
		N10-020-211	N10-021-211	G 3/8 LH	60	105	31	15	10	17	68,5	42	40	1,1
		N10-020-214	N10-021-214	3/8 NPT RH	60	105	31	6	10	17	76	42	40	1,1
		N10-020-215	N10-021-215	3/8 NPT LH	60	105	31	6	10	17	76	42	40	1,1
15	1/2	N12-020-210	N12-021-210	G 1/2 RH	66	112,5	32,5	15	14	22	74	48	45	1,4
		N12-020-211	N12-021-211	G 1/2 LH	66	112,5	32,5	15	14	22	74	48	45	1,4
		N12-020-214	N12-021-214	1/2 NPT RH	66	112,5	32,5	8	14	22	79,5	48	45	1,4
		N12-020-215	N12-021-215	1/2 NPT LH	66	112,5	32,5	8	14	22	79,5	48	45	1,4

Duoflow Rotating Union

DN	B NPT	O NPT	Ordering No.		A Rotor Connections	C ∅	D	E	F*	G ∅	H ⌀	J	L	M	M1	M2	N	P NPT	kg
			Steam	Hot Oil															
15	1/2	1/4	N12-022-210-701	N12-023-210-701	G 1/2 RH	66	139,5	32,5	15	14	22	74	116,5	48	45	22	42	1/8	1,5
			N12-022-211-701	N12-023-211-701	G 1/2 LH	66	139,5	32,5	15	14	22	74	116,5	48	45	22	42	1/8	1,5
			N12-022-214-701	N12-023-214-701	1/2 NPT RH	66	139,5	32,5	8	14	22	79,5	116,5	48	45	22	42	1/8	1,5
			N12-022-215-701	N12-023-215-701	1/2 NPT LH	66	139,5	32,5	8	14	22	79,5	116,5	48	45	22	42	1/8	1,5

*F-dimension on NPT rotor threads = engagement depth (wrench tight)

DEUBLIN

Rotating Union 9000 Series for Steam or Hot Oil Service, DN 20 - 50

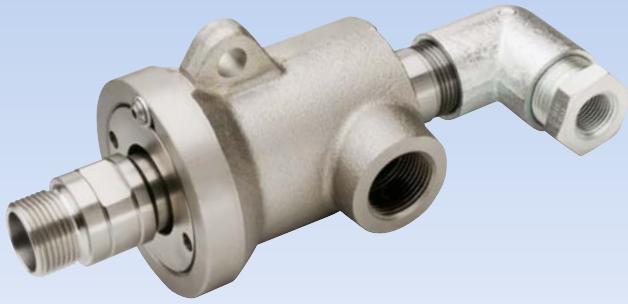

Operating Data

Max. Saturated Steam Pressure*	150 PSI	10 bar
Max. Temperature	365 °F	185 °C
Max. Hot Oil Pressure*	100 PSI	7 bar
Max. Speed*	400 RPM	400 min ⁻¹
Max. Temperature	230 °C	> 230 °C consult DEUBLIN
For Ordering No. 9200-014 T _{max} = 200 °C		

* Operation at max. pressure combined with max. speed is not permissible

- monoflow and duoflow design
- self-supported rotating union
- spherical seal; lapped Carbon Graphite Rings
- seal wear indicator allows preventive maintenance
- 2 torque lugs on the housing
- nickel-plated cast iron housing
- steel rotor, nickel-plated for steam service

Available alternatives: New "HT" series.

For further information please contact **DEUBLIN** or your local representative.

Monoflow Rotating Union for Steam and Hot Oil

Dimension D1; E and J for
Model 9075-014: minus 3 mm
9100-014: minus 2 mm
9125-014: minus 7 mm
9150-014: minus 4 mm

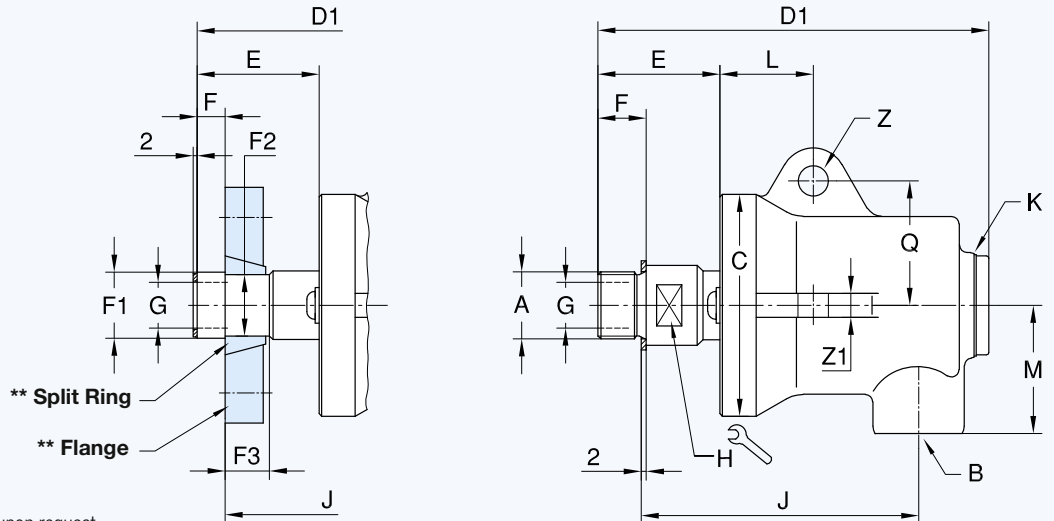

** supplied by customer, data sheet available upon request

Monoflow Rotating Union

DN	B	Ordering No.		A	C	D1	E	F	F1	F2	F3	G	H	J	K	L	M	Q	Z	Z1	kg
		Steam	Hot Oil																		
20	G 3/4	9075-008-110	9075-014-126	G 3/4	RH	87	155	48	19	-	-	18	27	109	G 1	37	51	49	12	13	2,4
	G 3/4	9075-008-111	9075-014-127	G 3/4	LH	87	155	48	19	-	-	18	27	109	G 1	37	51	49	12	13	2,4
	G 3/4	9075-008-117	9075-014-128	For Quick Connect Flange		87	155	48	11,1	26,0 25,9	24,25 24,15	17,5	18	-	115	G 1	37	51	49	12	13
25	G 1	9100-008-113	9100-014-211	G 1	RH	97	184	60	22	-	-	25,4	32	129	G 1	38	54	54	13	13	3,7
	G 1	9100-008-112	9100-014-212	G 1	LH	97	184	60	22	-	-	25,4	32	129	G 1	38	54	54	13	13	3,7
	G 1	9100-008-121	9100-014-213	For Quick Connect Flange		97	184	60	11,1	32,36 32,23	30,89 30,76	17,5	25,4	-	138	G 1	38	54	54	13	13
32	G 1 1/4	9125-008-118	9125-014-137	G 1 1/4	RH	112	206	65	25,4	-	-	32	41	140	G 1 1/2	42	66	60	13,5	13	6,3
	G 1 1/4	9125-008-119	9125-014-138	G 1 1/4	LH	112	206	65	25,4	-	-	32	41	140	G 1 1/2	42	66	60	13,5	13	6,3
	G 1 1/4	9125-008-126	9125-014-141	For Quick Connect Flange		112	206	65	12,7	41,0 40,9	39,65 39,55	19	32	-	150	G 1 1/2	42	66	60	13,5	13
40	G 1 1/2	9150-008-113	9150-014-197	G 1 1/2	RH	136	230	62	28,5	-	-	38	46	153	G 1 1/2	55	79	73	16	19	8,7
	G 1 1/2	9150-008-114	9150-014-198	G 1 1/2	LH	136	230	62	28,5	-	-	38	46	153	G 1 1/2	55	79	73	16	19	8,7
	G 1 1/2	9150-008-117	9150-014-199	For Quick Connect Flange		136	230	62	12,7	47,37 47,27	45,09 44,99	22,2	38	-	167	G 1 1/2	55	79	73	16	19
50	G 2	9200-008-117	9200-014-119	G 2	RH	155	252	68	30	-	-	49	60	168	G 1 1/2	62	86	87	16	25,4	13,5
	G 2	9200-008-118	9200-014-120	G 2	LH	155	252	68	30	-	-	49	60	168	G 1 1/2	62	86	87	16	25,4	13,5
	G 2	9200-008-121	9200-014-122	For Quick Connect Flange		155	262	77	15,9	58,93 58,80	56,64 56,51	28,5	49	-	189	G 1 1/2	62	86	87	16	25,4

Duoflow Rotating Union for Steam

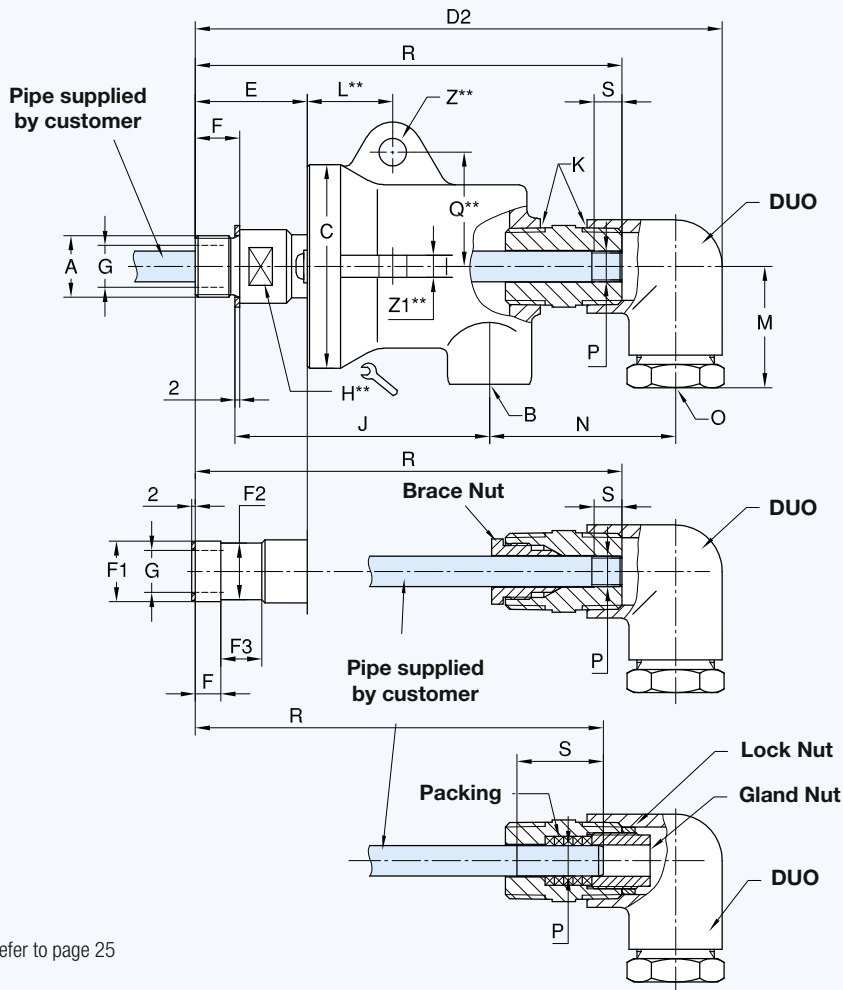

Type A
for short threaded supply pipe

Type B
for long threaded supply pipe
With additional brace nut for supply pipe. Use pipes as per DIN 2440 only.

Type C
for rotating supply pipe with packing seals to avoid interpassage leakage.

** Dimensions refer to page 25

Duoflow Rotating Union with Elbow for Steam

DN	B	O	Ordering No.	DUO *	Type	A Rotor Connections	C	D ₂	E	F	F ₁	F ₂	F ₃	G	J	K	M	N	P Pipe	Pipe DIN 2440	R	S	kg
							∅			∅ PT	∅			∅									
20	G 3/4	Rp 1/2	9075-008-110	-600	A	G 3/4 RH	87	220	48	19	-	-	-	18	109	R 1	51	75	G 1/4	DN 8	181	12	2,8
			9075-008-111	-610	B	G 3/4 LH				19	-	-	-						G 1/4	DN 8	181	12	
			9075-008-117	-620	C	For Quick Connect Flange				11,1	26,0 25,9	24,25 24,15	17,5						∅ 13 h9	DN 8	175	37	
25	G 1	Rp 1/2	9100-008-113	-600	A	G 1 RH	97	251	60	22	-	-	-	25,4	129	R 1	54	82	G 1/4	DN 8	210	12	4,1
			9100-008-112	-610	B														G 1 LH	22	-	-	
			9100-008-112	-611	B	G 1/4				DN 8	210	12											
			9100-008-112	-611	B	G 3/8				DN 10	210	12											
			9100-008-121	-621	C	For Quick Connect Flange				11,1	32,36 32,23	30,89 30,76	17,5		∅ 16 h9				DN 10	206	32		
32	G 1 1/4	Rp 3/4	9125-008-118	-600	A	G 1 1/4 RH	112	298	65	25,4	-	-	-	32	140	R 1 1/2	66	107	G 1/2	DN 15	238	14	7
			9125-008-118	-601	A														G 3/4	DN 20	238	16	
			9125-008-119	-610	B	G 1 1/4 LH				25,4	-	-	-		G 1/2				DN 15	238	14		
			9125-008-119	-611	B										G 3/4				DN 20	238	16		
			9125-008-126	-621	C	For Quick Connect Flange				12,7	41,0 40,9	39,65 39,55	19		∅ 20 h9				DN 15	230	40		
40	G 1 1/2	Rp 3/4	9150-008-113	-600	A	G 1 1/2 RH	136	322	62	28,5	-	-	-	38	153	R 1 1/2	79	114	G 1/2	DN 15	262	14	9,5
			9150-008-113	-601	A														G 3/4	DN 20	262	16	
			9150-008-114	-610	B	G 1 1/2 LH				28,5	-	-	-		G 1/2				DN 15	262	14		
			9150-008-114	-611	B										G 3/4				DN 20	262	16		
			9150-008-117	-621	C	For Quick Connect Flange				12,7	47,37 47,27	45,09 44,97	22,5		∅ 26 h9				DN 20	255	35		
50	G 2	Rp 3/4	9200-008-117	-600	A	G 2 RH	155	345	68	30	-	-	-	49	168	R 1 1/2	87	121	G 1/2	DN 15	284	14	14,3
			9200-008-117	-601	A														G 3/4	DN 20	284	16	
			9200-008-118	-610	B	G 2 LH				30	-	-	-		G 1/2				DN 15	284	14		
			9200-008-118	-611	B										G 3/4				DN 20	284	16		
			9200-008-121	-621	C	For Quick Connect Flange				354	77	15,9	58,93 58,80		56,64 56,51				22,2	∅ 26 h9	DN 20	276	

* Adhering to the same DN size, all unions can be combined with their respective elbows

** R dimension add 9 mm each

Duoflow Rotating Union for Hot Oil

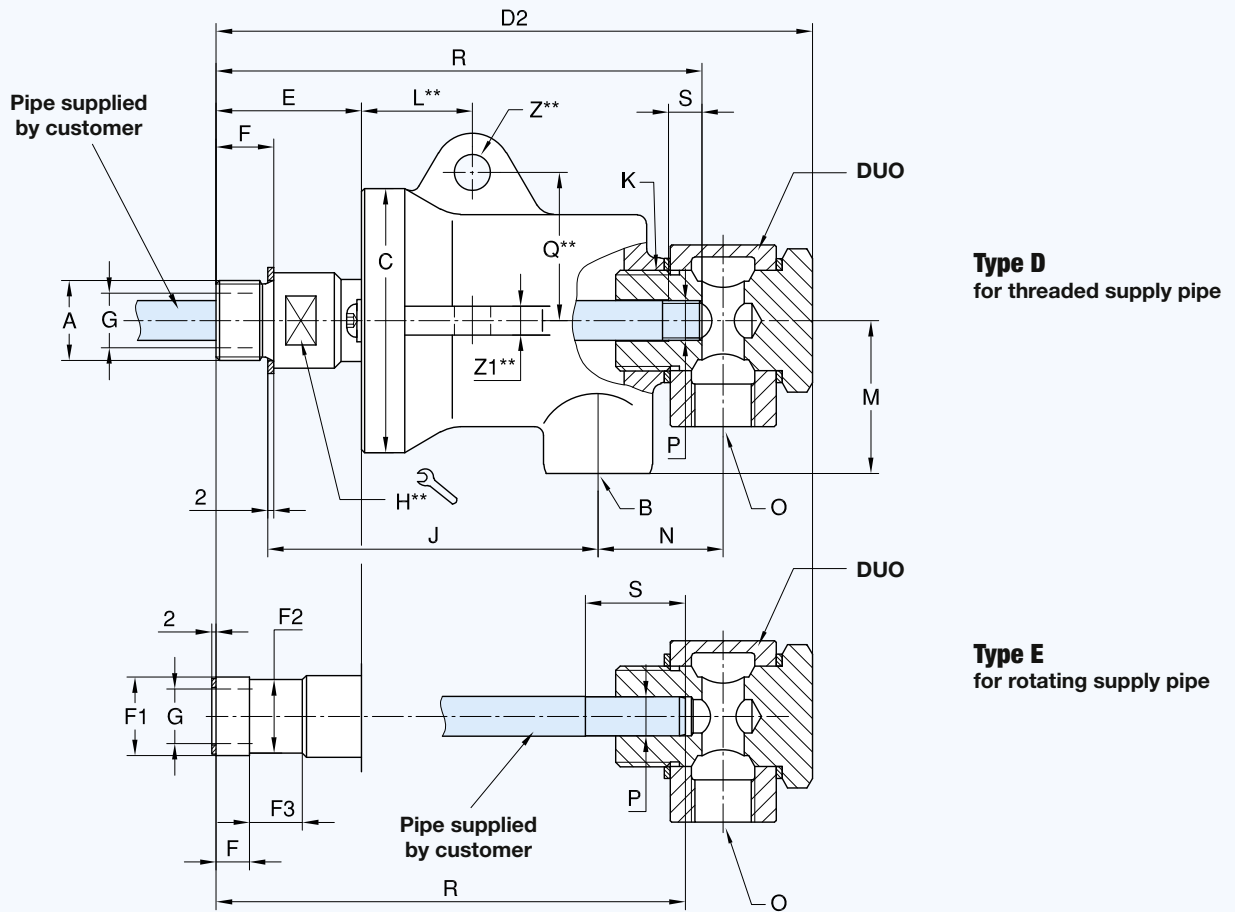

** Dimensions refer to page 25

Duoflow Rotating Union with Elbow for Hot Oil

DN	B	O	Ordering No.	DUO *	Type	A Rotor Connections	C	D2	E	F	F1	F2	F3	G	J	K	M	N	P Pipe	Pipe DIN 2440	R	S	kg
20	G 3/4	G 1/2	9075-014-126	-500	D	G 3/4 RH	87	194	45	19	-	-	-	18	106	G 1	51	40	G 1/4	DN 8	157	11	3
			G 3/4 LH			19				-	-	-											
			9075-014-127	-510	E	For Quick Connect Flange				11,1	26,0 25,9	24,25 24,15	17,5	112	ø 13 h13	DN 8	150	30					
9075-014-128																							
25	G 1	G 1/2	9100-014-211	-501	D	G 1 RH	97	225	58	22	-	-	-	25,4	127	G 1	54	48	G 3/8	DN 10	188	13	4,2
			G 1 LH			22				-	-	-											
			9100-014-212	-511	E	For Quick Connect Flange				11,1	32,36 32,23	30,89 30,76	17,5	136	ø 16 h13	DN 10	180	30					
9100-014-213																							
32	G 1 1/4	G 3/4	9125-014-137	-500	D	G 1 1/4 RH	112	246	58	25,4	-	-	-	32	133	G 1 1/2	66	58	G 1/2	DN 15	205	16	7,1
			G 1 1/4 LH			25,4				-	-	-											
			9125-014-138	-514	E	For Quick Connect Flange				12,7	41,0 40,9	39,65 39,55	19	143	ø 20 h13	DN 15	199	40					
9125-014-141																							
40	G 1 1/2	G 3/4	9150-014-197	-501	D	G 1 1/2 RH	136	273	58	28,5	-	-	-	38	149	G 1 1/2	79	65	G 3/4	DN 20	230	19	9,6
			G 1 1/2 LH			28,5				-	-	-											
			9150-014-198	-512	E	For Quick Connect Flange				12,7	47,37 47,27	45,09 44,97	22,5	163	ø 26 h13	DN 20	233	45					
9150-014-199																							
50	G 2	G 1	9200-014-119	-503	D	G 2 RH	155	302	68	30	-	-	-	49	168	G 1 1/2	87	73	G 1	DN 25	257	22	15
			G 2 LH			30				-	-	-											
			9200-014-120	-515	E	For Quick Connect Flange				15,9	58,93 58,80	56,64 56,51	22,2	189	ø 32 h13	DN 25	262	45					
9200-014-122																							

* Adhering to the same DN size, all unions can be combined with their respective elbows

** R dimension add 9 mm each

DEUBLIN

Rotating Union HPS Series for Steam Service in Corrugators, DN 40

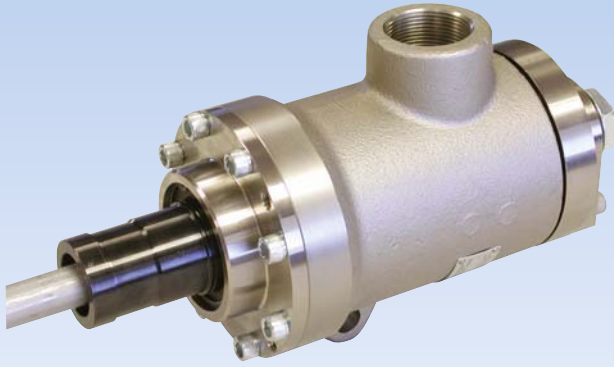

Operating Data

Max. Saturated Steam Pressure	250 PSI	17 bar
Max. Temperature	400 °F	200 °C
Max. Speed	400 RPM	400 min ⁻¹

- monoflow and duoflow design
- self-supported rotating union
- seals and outboard bearing made of impregnated Carbon Graphite
- convex seal ring reduces compression on Carbon ring; better suited to handle mechanical and thermal shock
- external mechanism to adjust siphon pipe through end cap
- nickel plated front and rear end cap
- nickel-plated ductile iron housing
- stainless steel spring
- heavy duty steel rotor design

For further information please contact **DEUBLIN** or your local representative.

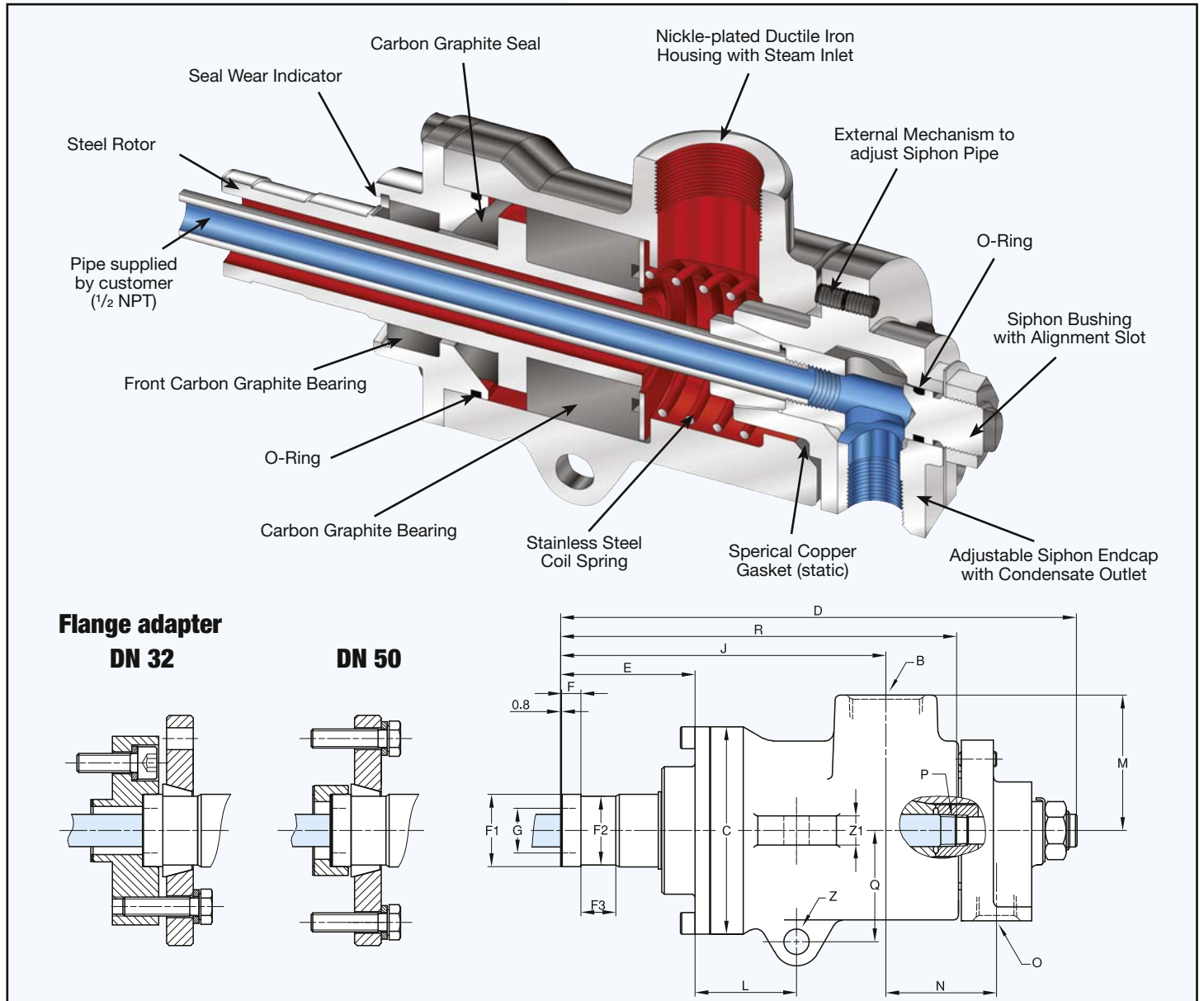

Flange adapter DN 32

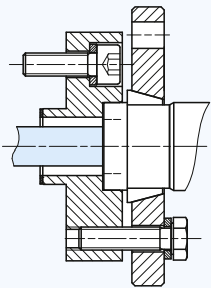

DN 50

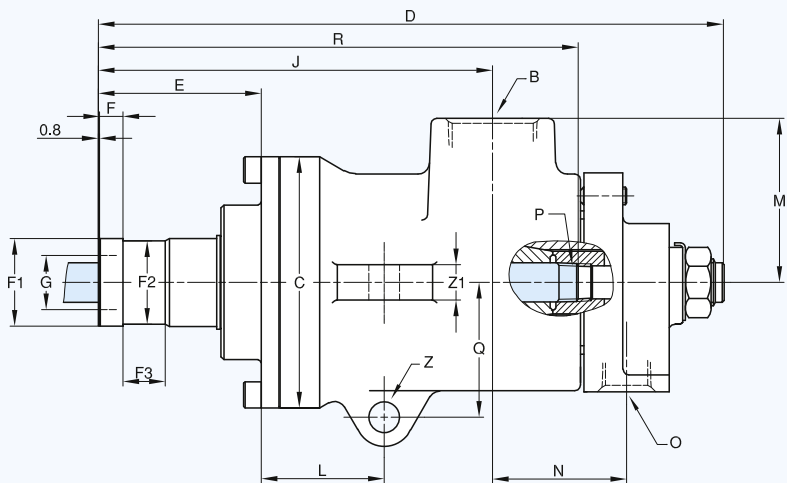
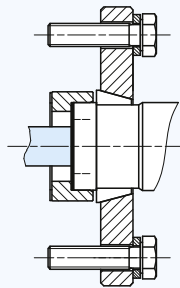

DN	B	O	Ordering No.	C ∅	D	E	F	F1 ∅	F2 ∅	F3	G ∅	J	L	M	N	P	Q	R	Z ∅	Z1
40	Rc 1 1/2	Rc 3/4	C15D-005-02-3A	136	340	88	12,7	47,50 47,45	45,19 45,11	23	33,4	215	69	90	73	1/2 NPT	73	258	16,7	21

DEUBLIN

Rotating Union H Series for Steam or Hot Oil Service, DN 20 - 125

- monoflow and duoflow design
- self-supported rotating union
- designed for steam and hot oil applications in paper, plastics and textile industries
- effective on a variety of applications, especially on open gear paper machines
- pressurised spherical carbon graphite seal
- Ni-Resist counterface
- two widely spaced graphite bearings
- H57 – H127 optional with sight glasses in the end cap for visual inspection of condensate removal
- seal wear indicator allows preventive maintenance
- flanged or threaded rotor available
- cast iron housing
- steel rotor

For further information please contact **DEUBLIN** or your local representative.



Operating Data

Max. Saturated Steam Pressure*	150 PSI	10 bar
Max. Temperature	365 °F	185 °C
Max. Speed*	DN 20- 50 180 RPM	180 min ⁻¹
	DN 65-125 400 RPM	400 min ⁻¹
Max. Hot Oil Pressure*	100 PSI	7 bar
Max. Speed*	DN 20- 50 350 RPM	350 min ⁻¹
	DN 65-125 400 RPM	400 min ⁻¹
Max. Temperature	230 °C	> 230 °C consult DEUBLIN

* Operation at max. pressure combined with max. speed is not permissible

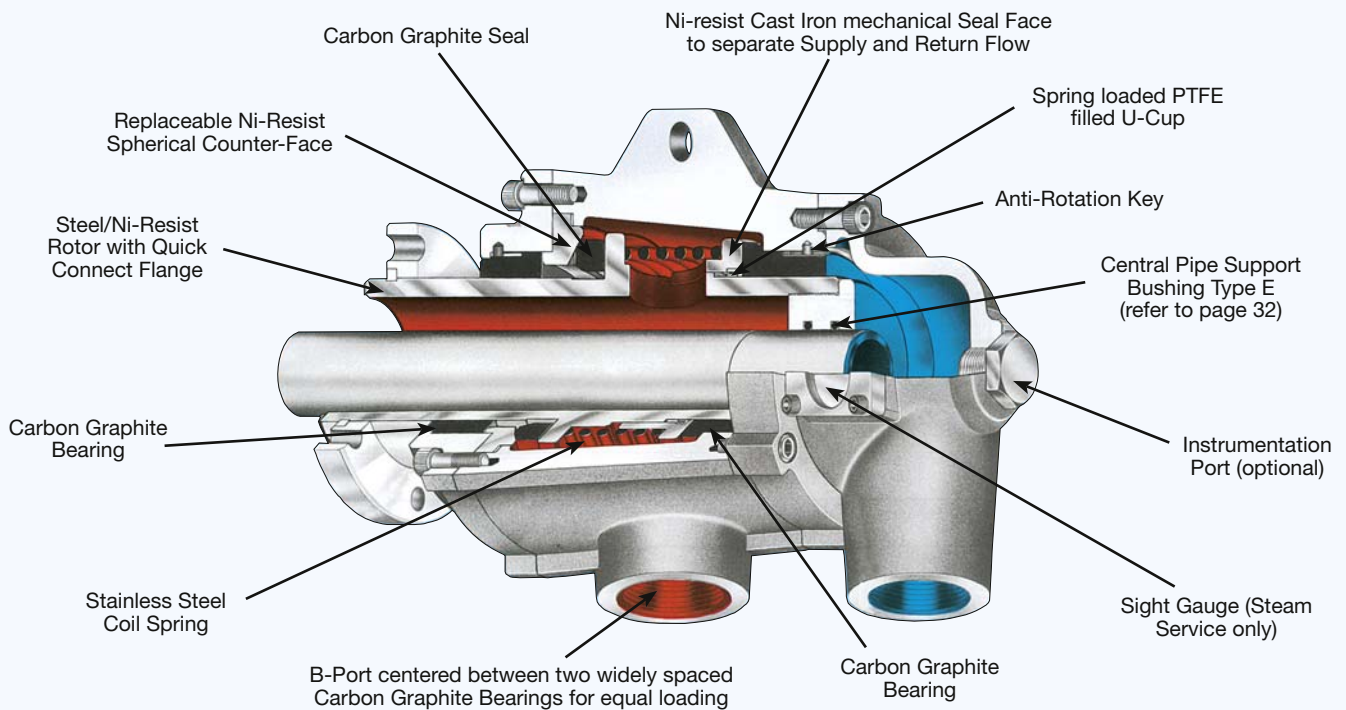

The rotating unions of the H Series can be used with the **DEUBLIN** Siphon Systems. Rotating and non-rotating siphon systems can be customised to meet any/all requirements. For further information please refer to our catalogue "Rotating Joints and Siphon Systems for the Paper Industry" or contact **DEUBLIN** directly.

Example for Stationary Siphon System

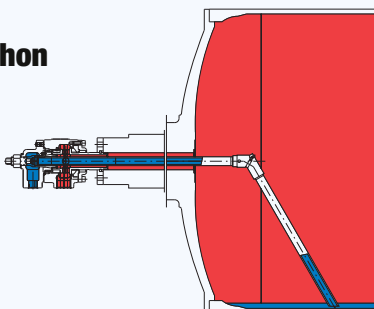

Example for Rotating Siphon System

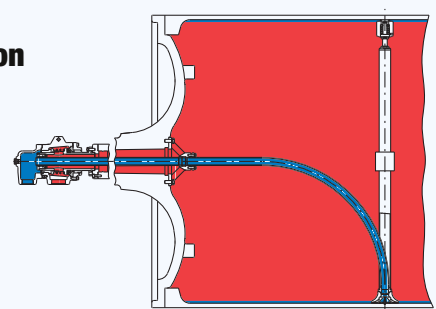

Monoflow Rotating Union, Models Size H20 - H40 and

H57 - H87

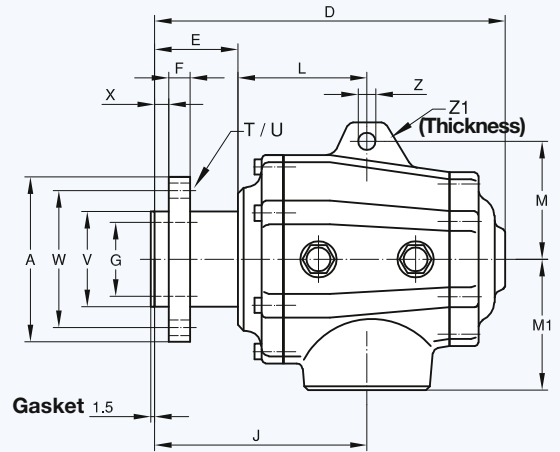
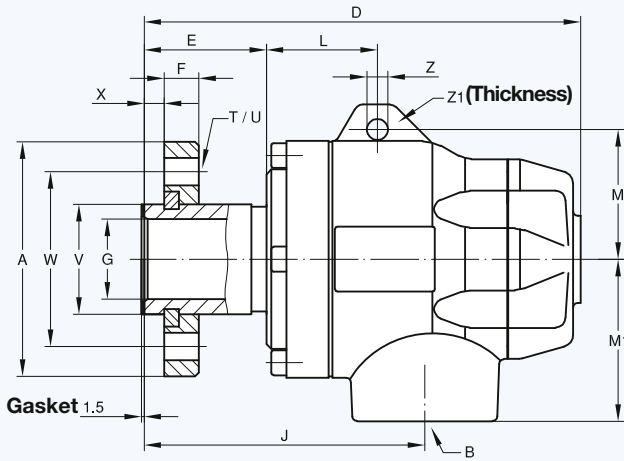

Models Size H107 and H127

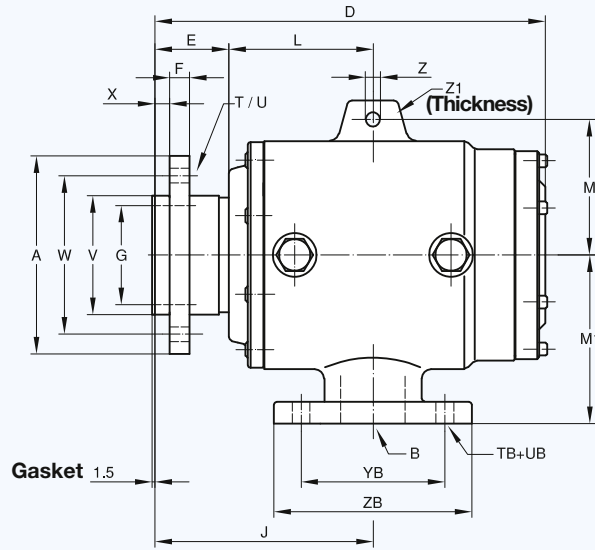

Monoflow Rotating Union

DN	B	Model M	A ∅	D	E	F	G ∅	J	L	M	M ₁
20	G 3/4	H20	69	140	40	12	18	95	59	45	50
25	G 1	H25	78	165	47	12	24,5	101	44	50	60
32	G 1 1/4	H32	94	175	49	14	32	112,5	44,5	52	65
40	G 1 1/2	H40	99	204	61	14	38	136,5	51	70	75
50	G 2	H57	120	258	60,5	14	47	151	90,5	83	95
65	G 2 1/2	H67	138,5	300	70	18	62	178,5	108,5	99	110
80	G 3	H87	150	326	67,5	18	76,5	188	120,5	115	120
100	DN 100	H107	200	394	76,5	20	100	220	143,5	137	170
125	DN 125	H127	280	465	85	24	125	275	190	158	220

Duoflow Rotating Union

DN	B	O	Model E-R-S	A ∅	D	E	F	G ∅	J	L	M	M ₁	M ₂	N
20	G 3/4	G 1/2	H20	69	195	40	12	18	95	59	45	50	30	86
25	G 1	G 1/2	H25	78	220	47	12	24,5	101	44	50	60	30	104
32	G 1	G 3/4	H32	94	203	49	14	32	112,5	44,5	52	65	65	60,5
40	G 1 1/4	G 1	H40	99	245	61	14	38	136,5	51	70	75	75	71,5
50	G 1 1/2	G 1 1/4	H57	120	303	60,5	14	47	151	90,5	83	95	95	97
65	G 2	G 1 1/2	H67	138,5	359	70	18	62	178,5	108,5	99	110	110	124,5
80	G 2 1/2	G 2	H87	150	396	67,5	18	76,5	188	120,5	115	120	120	146
100	DN 80	DN 65	H107	200	562,5	76,5	20	100	220	143,5	137	170	170	251
	DN 65	DN 65	H107 *	200	563,5	76,5	20	100	220	143,5	137	170	170	251
125	DN 100	DN 65	H127	280	617,5	85	24	125	275	190	158	220	220	250
	DN 80	DN 80	H127 *	280	625	85	24	125	275	190	158	220	220	250

* Hot Oil Design

Duoflow Rotating Union, Models Size H20 - H40 and

H57 - H87

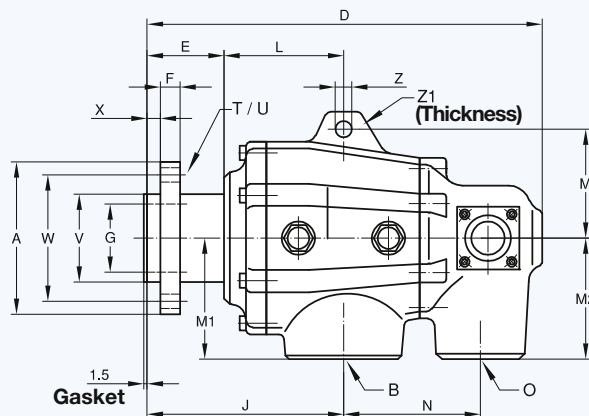
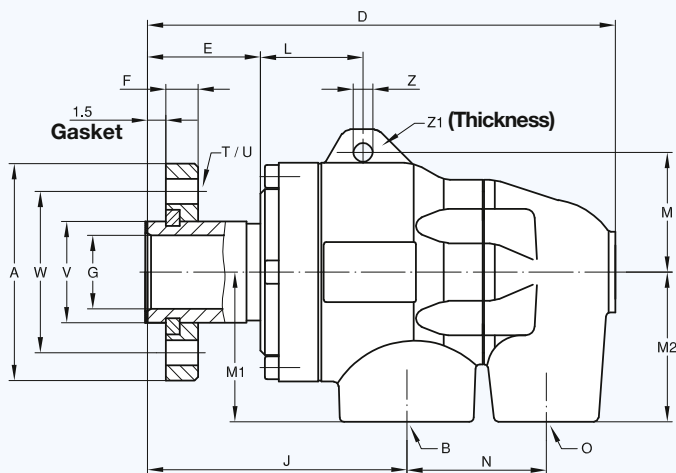

Models Size H107 and H127

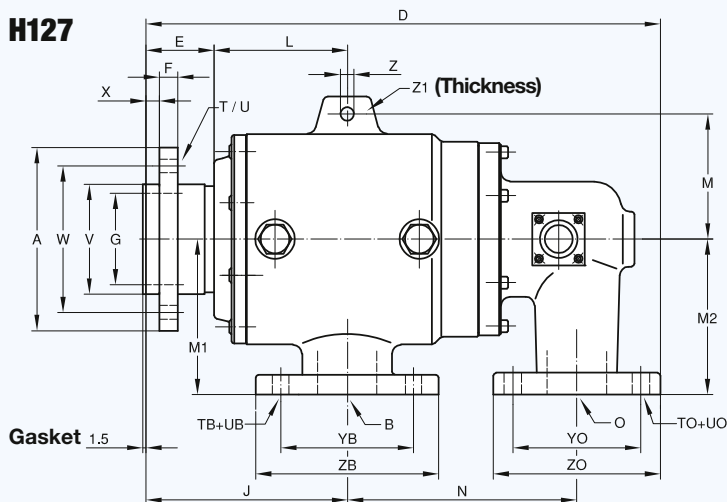

T	U ∅	TB	UB ∅	V ∅ h7	W ∅	X	YB ∅	ZB ∅	Z ∅	Z ₁	DN
4 x 90°	9	-	-	30	50	6	-	-	7	8	20
4 x 90°	9	-	-	36	60	7	-	-	7	11	25
4 x 90°	11	-	-	44	70	8	-	-	8,5	8	32
4 x 90°	11	-	-	52	78	10	-	-	11,5	10	40
4 x 90°	11	-	-	65	95	10	-	-	13	15	50
4 x 90°	13	-	-	80	115	12	-	-	15	20	65
4 x 90°	13	-	-	95	125	12	-	-	15	25	80
6 x 60°	15	8 x 45°	18	120	160	15	180	220	15	25	100
6 x 60°	18	8 x 45°	18	160	225	15	210	250	15	25	125

T	U ∅	TB	UB ∅	TO	UO ∅	V ∅ h7	W ∅	X	YB ∅	ZB ∅	YO ∅	ZO ∅	Z ∅	Z ₁	DN
4 x 90°	9	-	-	-	-	30	50	6	-	-	-	-	7	8	20
4 x 90°	9	-	-	-	-	36	60	7	-	-	-	-	7	11	25
4 x 90°	11	-	-	-	-	44	70	8	-	-	-	-	8,5	8	32
4 x 90°	11	-	-	-	-	52	78	10	-	-	-	-	11,5	10	40
4 x 90°	11	-	-	-	-	65	95	10	-	-	-	-	13	15	50
4 x 90°	13	-	-	-	-	80	115	12	-	-	-	-	15	20	65
4 x 90°	13	-	-	-	-	95	125	12	-	-	-	-	15	25	80
6 x 60°	15	8 x 45°	18	4 x 90°	18	120	160	15	160	200	145	185	15	25	100
6 x 60°	15	4 x 90°	18	4 x 90°	18	120	160	15	145	185	145	185	15	25	
6 x 60°	18	8 x 45°	18	4 x 90°	18	160	225	15	180	220	145	185	15	25	
6 x 60°	18	8 x 45°	18	8 x 45°	18	160	225	15	160	200	160	200	15	25	125

Duoflow Central Pipe Specifications

Rotating Central Pipe

R For rotating siphon (steam inlet pipe) the inner pipe is connected by means of a threaded bushing that screws into the rotor.

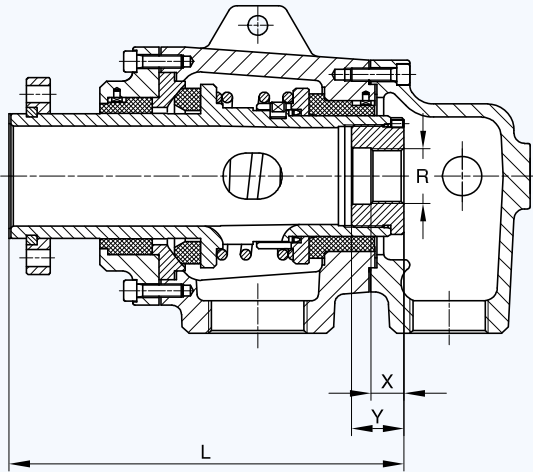

Rotating Central Pipe axial Movement

E For a rotating siphon capable of axial movement a sliding connection is made between the bushing and the central pipe to allow for the thermal expansion of the central pipe.

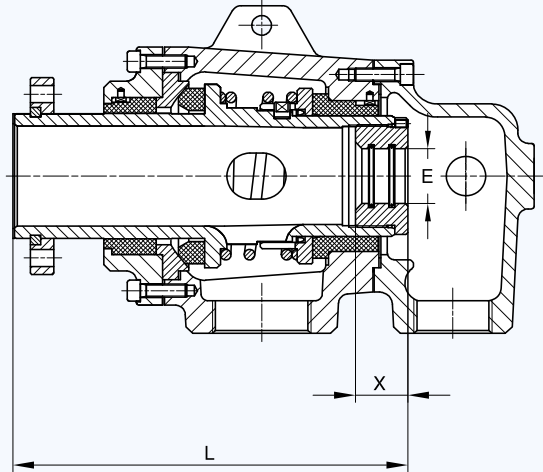

Model	L	X	Y	Design							
				Ra	Rb	Rc	Rd	Re	Rf	Rg	
H20	117	15	20	-	G 1/8	G 1/4	-	-	-	-	-
H25	133	15	20	-	G 1/4	G 3/8	-	-	-	-	-
H32	147	20	25	-	G 3/8	G 1/2	-	-	-	-	-
H40	175	25	30	G 1/2	G 3/4	G 1	-	-	-	-	-
H57	233	25	35	-	G 3/4	G 1	-	G 1 1/4	-	-	-
H67	273	25	35	G 1/2	G 3/4	G 1	-	G 1 1/4	G 1 1/2	-	-
H87	300	25	40	G 1	-	G 1 1/4	G 1 1/2	G 2	-	-	-
H107	375	45	60	G 1	-	G 1 1/4	G 1 1/2	G 2	G 2 1/2	G 3	-
H127	460	45	60	G 1 1/4	G 1 1/2	G 2	G 2 1/2	G 3	G 4	-	-

Model	L	X	Design							
			Ea	Eb	Ec	Ed	Ee	Ef	Eg	
H20	117	20	-	9,5	13	-	-	-	-	-
H25	133	20	-	13	17	-	-	-	-	-
H32	147	25	-	17	21	-	-	-	-	-
H40	175	30	21	26,6	31	-	-	-	-	-
H57	233	35	21	26,6	33,3	37,6	42	-	-	-
H67	273	35	21	26,6	33,3	37,6	42	48	-	-
H87	300	40	33,3	37,6	42	47,9	59,8	-	-	-
H107	375	60	33,7	38	42,4	48,3	60,3	76,1	88,9	-
H127	460	60	42,4	48,3	60,3	76,1	88,9	101,6	-	-

Stationary Central Pipe

S For fixed siphons the pipe is connected by means of a threaded bushing that screws into the end cap.

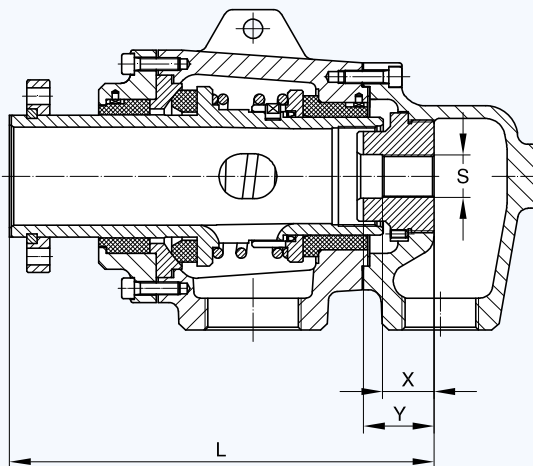

Stationary Central Pipe

SK For stationary fixed siphons where the central pipe is supported in the end cap and connected by means of an external bolt to the end cap.

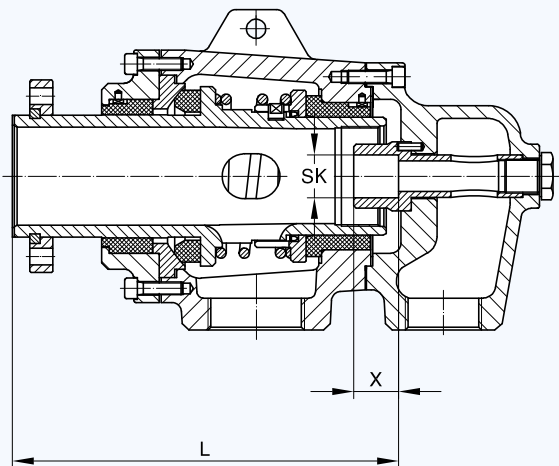

Model	L	X	Y	Design					
				Sa	Sb	Sc	Sd	Se	Sf
H20	137	11	16	-	G 1/8	G 1/4	-	-	-
H25	160	11	20	-	G 1/4	G 3/8	-	-	-
H32	172	15	25	-	G 3/8	G 1/2	-	-	-
H40	206	20	30	G 1/2	G 3/4	G 1	-	-	-
H57	250,5	25	40	G 1/2	G 3/4	G 1	-	G 1 1/4	-
H67	303	30	40	G 1/2	G 3/4	G 1	-	G 1 1/4	G 1 1/2
H87	330	35	50	G 1	-	G 1 1/4	G 1 1/2	G 2	-
H107	-	-	-	-	-	-	-	-	-
H127	-	-	-	-	-	-	-	-	-

Model	L	X	Design	
			SKa	SKb
H57	227,5	30	21	26,6
H67	276,5	30	26,6	33
H87	294,5	30	33	42
H107	375	60	33,7	38
H127	460	60	42,4	48,3

Adjustable Siphon available

Consult DEUBLIN Engineering!

DEUBLIN

Rotating Union 14000 Series for Air and Hydraulic Oil Service, DN 10 - 50



Operating Data

Max. Air Pressure	150 PSI	10 bar
Max. Vacuum	2" Hg	7 kPa
Max. Hydraulic Pressure* (DN 10-20)	870 PSI	60 bar
(DN 25-40)	580 PSI	40 bar
Max. Speed* (DN 10-40)	1,500 RPM	1.500 min ⁻¹
(DN 50)	750 RPM	750 min ⁻¹
Max. Temperature	120 °C	> 120 °C consult DEUBLIN

Recommended filtration of Hydraulic Oil: 5 µm
* Operation at max. pressure combined with max. speed is not permissible

- monoflow design
- self-supported rotating union or in-the-shaft mounted
- balanced mechanical seal
Carbon Graphite/Ceramic - for air service;
Tungsten Carbide/Ceramic - for hydraulic service
- axial or radial housing connection by means of elbow
- lubrication storage within the seal cavity for air service
- heavy-duty design
- steel housing
- stainless steel rotor
- full-media flow

For further information please contact **DEUBLIN** or your local representative.

Axial Version

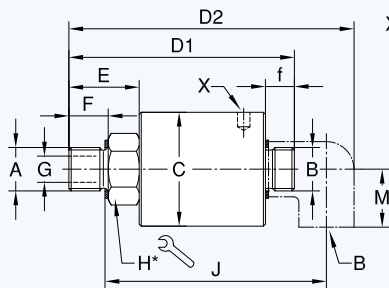

X: Hole for Spanner Wrench as per DIN 1810, for sizes see table below.

In-the-Shaft Mounted Version

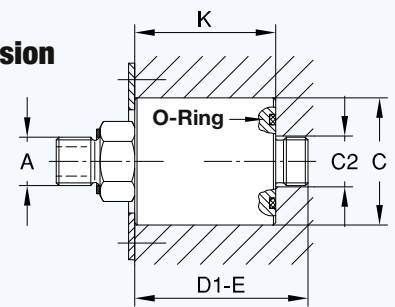

How to Order: Type a: 14037-03-094, straight-through version
Type b: 14037-03-094-118, with elbow

Type c: 14037-03-094-120, in-the-shaft mounted version
Type d: 14037-03-094-121, with elbow and O-ring.

* DN 10 - 20 = hexagon
DN 25 - 50 = two wrench flats

DN	B	Ordering No.		Type			A	C _{R8} ^{Eg}	C ₂	D ₁	D ₂	E	F	f	G	H	J	K	M	X	kg	
		Type a for Air CG/C with lubricator	Type a for Hydr. Oil TC/C	b	c	d																Rotor Connections
10	G 3/8	14037-03-094	14037-04-192	-118	-120	-121	G 3/8	RH	42	18	93	119	26	16	12	9,5	22	93	54,5	25	4	0,5
	G 3/8	14037-03-095	14037-04-193				G 3/8	LH	42	18	93	119	26	16	12	9,5	22	93	54,5	25	4	0,5
15	G 1/2	14050-03-151	14050-04-154	-118	-120	-121	G 1/2	RH	55	22	109	138	34	19	14	12,7	30	107	60,5	28	6	1
	G 1/2	14050-03-152	14050-04-160				G 1/2	LH	55	22	109	138	34	19	14	12,7	30	107	60,5	28	6	1
20	G 3/4	14075-03-284	14075-04-447	-118	-120	-121	G 3/4	RH	63	28	122	158	34	19	16	17,5	36	124	71,5	33	6	1,7
	G 3/4	14075-03-285	14075-04-448				G 3/4	LH	63	28	122	158	34	19	16	17,5	36	124	71,5	33	6	1,7
	G 3/4	14075-03-458	14075-04-936				M27 x 1,5	RH	63	28	123	159	35	15	16	17,5	36	121	71,5	33	6	1,7
	G 3/4	14075-03-459	14075-04-937				M27 x 1,5	LH	63	28	123	159	35	15	16	17,5	36	121	71,5	33	6	1,7
	G 3/4	14075-03-014	14075-04-451				M 35 x 1,5	RH	63	28	126	161	38	15	16	17,5	41	131	71,5	33	6	1,7
	G 3/4	14075-03-015	14075-04-452				M 35 x 1,5	LH	63	28	126	161	38	15	16	17,5	41	131	71,5	33	6	1,7
25	G 1	14100-03-222	14100-04-378	-118	-120	-121	G 1	RH	80	35	138	181	41	22	18	25	36	140	78,5	38	6	2,4
	G 1	14100-03-223	14100-04-379				G 1	LH	80	35	138	181	41	22	18	25	36	140	78,5	38	6	2,4
	G 1	14100-03-235	14100-04-381				M 35 x 1,5	RH	80	35	132	175	35	15	18	25	36	141	78,5	38	6	2,4
	G 1	14100-03-236	14100-04-382				M 35 x 1,5	LH	80	35	132	175	35	15	18	25	36	141	78,5	38	6	2,4
32	G 1 1/4	14125-03-054	14125-04-128	-118	-120	-121	G 1 1/4	RH	90	43	153	205	55	28	20	31,8	46	155	77,5	45	6	3,3
	G 1 1/4	14125-03-055	14125-04-129				G 1 1/4	LH	90	43	153	205	55	28	20	31,8	46	155	77,5	45	6	3,3
40	G 1 1/2	14150-03-198	14150-04-288	-118	-120	-121	G 1 1/2	RH	90	49	184	243	72	29	22	38	55	187	89,5	50	6	4
	G 1 1/2	14150-03-199	14150-04-289				G 1 1/2	LH	90	49	184	243	72	29	22	38	55	187	89,5	50	6	4
	G 1 1/2	14150-03-200	14150-04-418				M 50 x 1,5	RH	90	49	177	236	65	23	22	38	55	187	89,5	50	6	4
	G 1 1/2	14150-03-201	14150-04-419				M 50 x 1,5	LH	90	49	177	236	65	23	22	38	55	187	89,5	50	6	4
50	G 2	14200-03-124	---	-118	-120	-121	G 2	RH	110	61	205	275	65	29	25	47,6	60	213	114,5	58	10	6
	G 2	14200-03-125	---				G 2	LH	110	61	205	275	65	29	25	47,6	60	213	114,5	58	10	6



DEUBLIN

Rotating Union for Air and Hydraulic Oil Service, DN 6 - 40

- monoflow design
- self-supported rotating union
- radial housing connection
- balanced mechanical seal
Carbon Graphite/hardened Tool Steel or
Carbon Graphite/Ceramic
- felt oiler in seal cavity for air service
- oiler for relubrication (3 - 5 drops/month)
- low torque
- weight optimised design
- aluminium housing
- stainless steel or steel rotor (respective of model)
- Lubrication Guide page 52

Operating Data

Max. Air Pressure	150 PSI	10 bar
Max. Vacuum	2" Hg	7 kPa
Max. Hydraulic Pressure*		
Model 1005	1,020 PSI	70 bar
1102	1,020 PSI	70 bar
1115	510 PSI	35 bar
1205	730 PSI	50 bar
2200	1,020 PSI	70 bar
250-094	1,020 PSI	70 bar
355-021	1,020 PSI	70 bar
452-000	730 PSI	50 bar
Max. Speed Straight Threads*	3,500 RPM	3.500 min ⁻¹
Model 250-094	3,500 RPM	3.500 min ⁻¹
355-021	3,000 RPM	3.000 min ⁻¹
452-000	2,500 RPM	2.500 min ⁻¹

Max. Temperature 120 °C > 120 °C consult **DEUBLIN**

* Operation at max. pressure combined with max. speed is not permissible

For further information please contact **DEUBLIN** or your local representative.

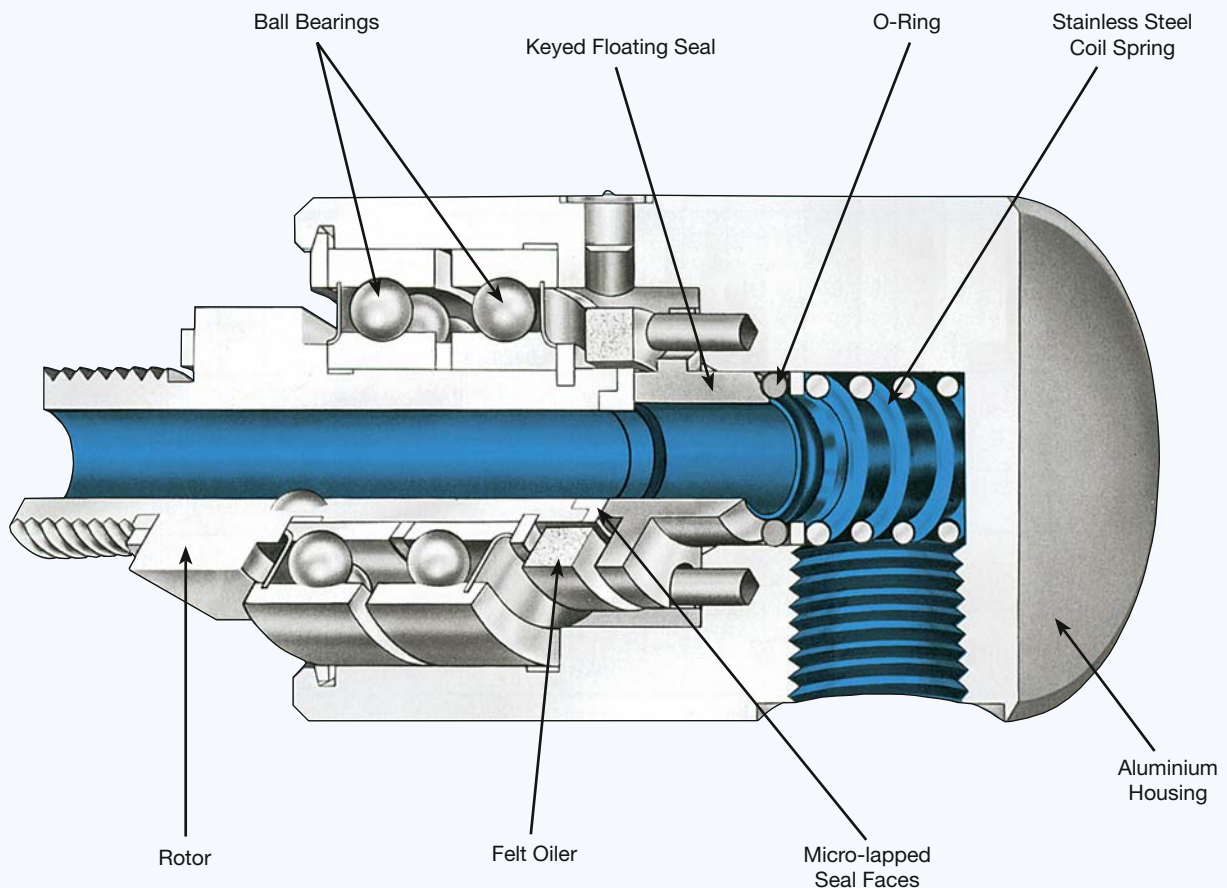

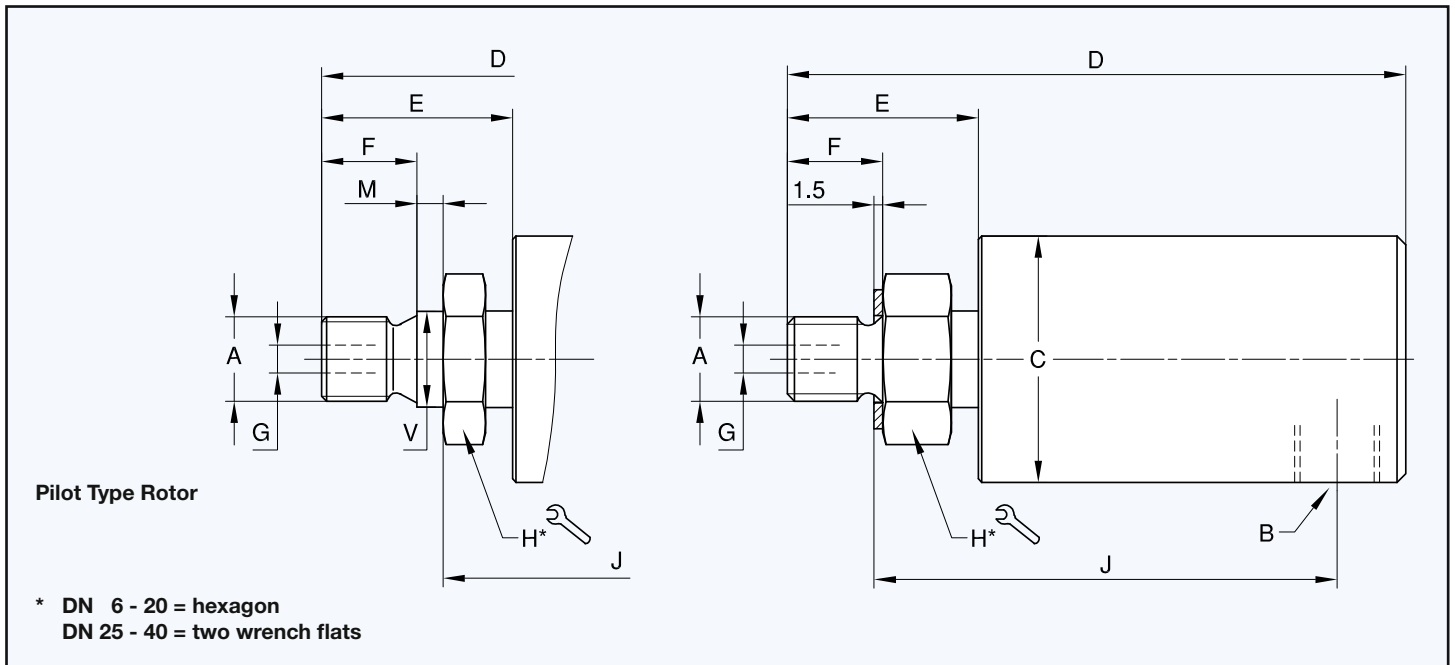

Monoflow Rotating Union

DN	B NPT	Ordering No.	A Rotor Connections		C ∅	D	E	F	G ∅	H* 	J	M	V ∅	 kg
6	1/8	1005-020-037	M 10 x 1	RH	28,5	71	22	11	3,2	17	54	-	-	0,2
	1/8	1005-020-045	M 10 x 1	RH	28,5	71	22	11	3,2	17	50	3	11 h6	0,2
	1/8	1005-020-049	G 1/4	RH	28,5	71	22	13	3,2	17	52	-	-	0,2
8	1/4	1102-070-103	G 1/4	RH	41	81	28	13	6,4	22	58	-	-	0,4
	1/4	1102-070-104	G 1/4	LH	41	81	28	13	6,4	22	58	-	-	0,4
10	3/8	1115-000-205	G 3/8	RH	44	99	26	16	8,7	24	71	-	-	0,7
	3/8	1115-000-200	M 16 x 2	RH	44	99	26	16	8,7	24	71	-	-	0,7
15	1/2	1205-000-151	G 1/2	RH	57	114	35	19	12,7	30	79	-	-	0,7
	1/2	1205-000-152	G 1/2	LH	57	114	35	19	12,7	30	79	-	-	0,7
	1/2	1205-000-170	M 20 x 1,5	RH	57	116	37	14	12,7	30	78	5	22 g6	0,7
	1/2	1205-000-171	M 20 x 1,5	LH	57	116	37	14	12,7	30	78	5	22 g6	0,7
	1/2	2200-000-458	M 27 x 1,5	RH	73	123	35	15	17,5	36	85	6	28 g6	1,4
	1/2	2200-000-459	M 27 x 1,5	LH	73	123	35	15	17,5	36	85	6	28 g6	1,4
	1/2	2200-000-081	M 35 x 1,5	RH	73	125	38	15	17,5	41	96	-	-	1,6
	1/2	2200-000-082	M 35 x 1,5	LH	73	125	38	15	17,5	41	96	-	-	1,6
	1/2	2200-000-102	G 3/4	RH	73	122	34	19	17,5	36	88	-	-	1,4
20	3/4	250-094-284	G 3/4	RH	73	128	34	19	17,5	36	94	-	-	1,6
	3/4	250-094-285	G 3/4	LH	73	128	34	19	17,5	36	94	-	-	1,6
	3/4	250-094-458	M 27 x 1,5	RH	73	129	35	15	17,5	36	91	6	28 g6	1,6
	3/4	250-094-459	M 27 x 1,5	LH	73	129	35	15	17,5	36	91	6	28 g6	1,6
	3/4	250-094-014	M 35 x 1,5	RH	73	131	38	15	17,5	41	101	-	-	1,6
	3/4	250-094-015	M 35 x 1,5	LH	73	131	38	15	17,5	41	101	-	-	1,6
25	1	355-021-222	G 1	RH	83	150	42	22	25	36	108	-	-	2,1
	1	355-021-223	G 1	LH	83	150	42	22	25	36	108	-	-	2,1
	1	355-021-235	M 35 X 1,5	RH	83	144	35	15	25	36	108	-	-	2,1
	1	355-021-236	M 35 X 1,5	LH	83	144	35	15	25	36	108	-	-	2,1
	1	355-021-315	M 35 x 1,5	RH	83	167	59	29	25	36	103	12	40 g6	2,1
	1	355-021-316	M 35 x 1,5	LH	83	167	59	29	25	36	103	12	40 g6	2,1
40	1 1/2	452-000-198	G 1 1/2	RH	108	206	71	29	38	55	147	-	-	4,5
	1 1/2	452-000-199	G 1 1/2	LH	108	206	71	29	38	55	147	-	-	4,5
	1 1/2	452-000-200	M 50 x 1,5	RH	108	200	66	23	38	55	147	-	-	4,5
	1 1/2	452-000-201	M 50 x 1,5	LH	108	200	66	23	38	55	147	-	-	4,5

DEUBLIN Rotating Unions In-the-Shaft Mounted

To meet the specifications of engineering designs requiring minimum overhang, **DEUBLIN** can provide unions which can be mounted in the shaft. With these models the only extensions beyond the end of the shaft are the supply line connections.

Detailed drawings suggesting the application of these **DEUBLIN** Unions to your installation will be submitted on request and without obligation.

For additional models of In-the-Shaft Mounted Rotating Unions refer to page 33.

Model 1005-000-001, DN 6

Operating Data

Max. Air Pressure	150 PSI	10 bar
Max. Hydraulic Pressure	1,020 PSI	70 bar
Max. Temperature	250 °F	120 °C
Max. Speed	3,500 RPM	3.500 min ⁻¹

Available with all 1005 rotors shown on page 35.

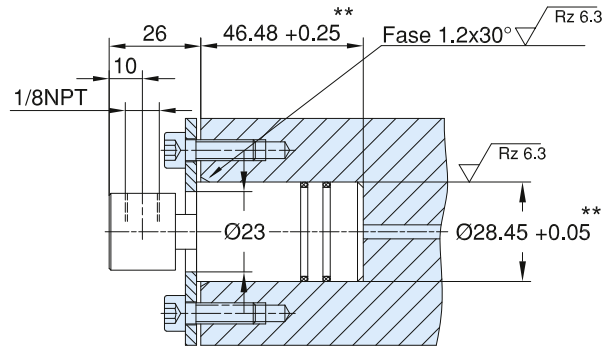

Model 1005-000-049, DN 6

Operating Data

Max. Air Pressure	150 PSI	10 bar
Max. Hydraulic Pressure	1,020 PSI	70 bar
Max. Temperature	250 °F	120 °C
Max. Speed	3,500 RPM	3.500 min ⁻¹

Available with all 1005 rotors shown on page 35.

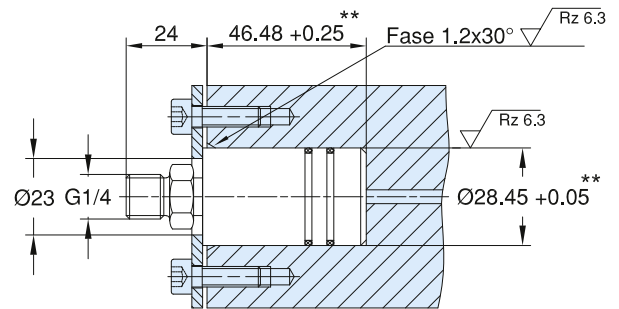

Model 1102-025-103, DN 8

Operating Data

Max. Air Pressure	150 PSI	10 bar
Max. Hydraulic Pressure	1,020 PSI	70 bar
Max. Temperature	250 °F	120 °C
Max. Speed	3,500 RPM	3.500 min ⁻¹

Available with all 1102 rotors shown on page 35.

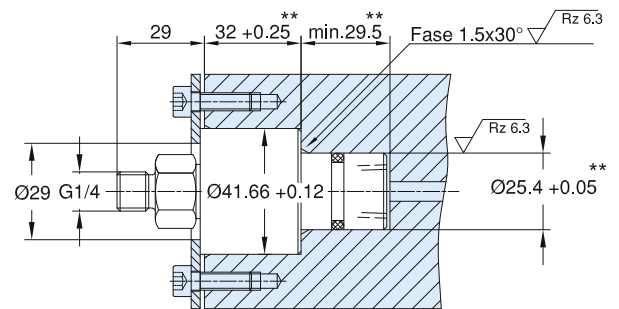

Model 1115-130-205, DN 10

Operating Data

Max. Air Pressure	150 PSI	10 bar
Max. Hydraulic Pressure	510 PSI	35 bar
Max. Temperature	250 °F	120 °C
Max. Speed	3,500 RPM	3.500 min ⁻¹

Available with all 1115 rotors shown on page 35.

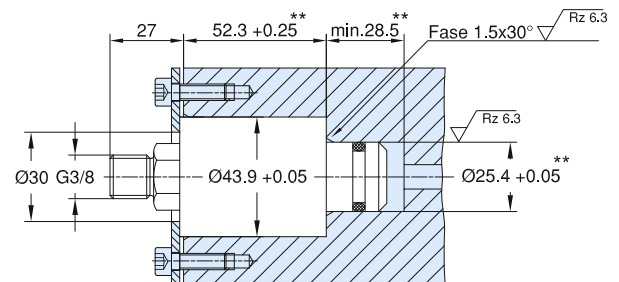

** Dimensions of Shaft Bore

DEUBLIN

Rotating Union D Series for Water and Hydraulic Oil Service, DN 8 - 40



- monoflow design
- self-supported rotating union
- for hydraulic oil and water
- for swivel applications and high media pressure
e.g. for power steering applications on earth moving equipment or hose reels
- steel housing and end cap
- stainless steel rotor
- can be adapted for other media upon request

For further information please contact **DEUBLIN** or your local representative.

Operating Data

Max. Hydraulic/Water Pressure	6,530 PSI	450 bar
Max. Speed	20 RPM	20 min ⁻¹
Max. Temperature	120 °C	> 120 °C consult DEUBLIN

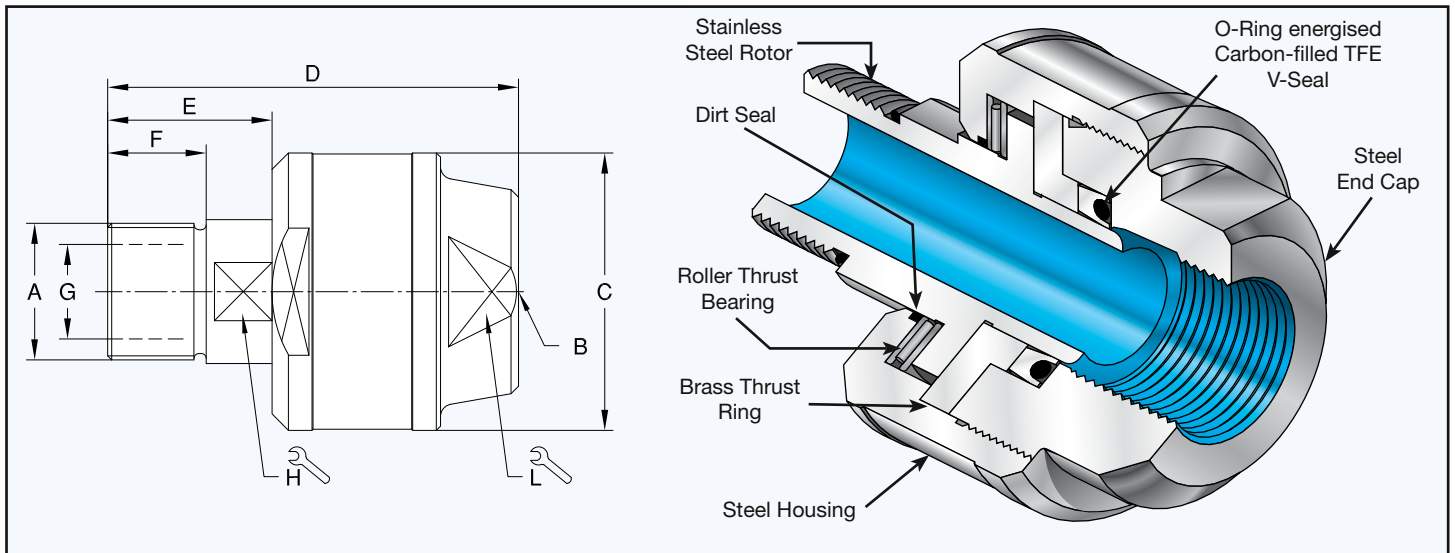

DN	B	Ordering No.	A Rotor Connections		C ∅	D	E	F	G ∅	H	L	kg
10	G 3/8	D10-003-210	G 3/8	RH	44	70	25	15	10	14	28	0,4
		D10-003-211	G 3/8	LH								
15	G 1/2	D12-003-210	G 1/2	RH	56	82	32	20	12	22	38	0,8
		D12-003-211	G 1/2	LH								
20	G 3/4	D20-003-210	G 3/4	RH	62	90	34	20	18	27	42	1,0
		D20-003-211	G 3/4	LH								
25	G 1	D25-003-210	G 1	RH	68	100	40	24	23	32	48	1,3
		D25-003-211	G 1	LH								
32	G 1 1/4	D32-003-210	G 1 1/4	RH	80	108	43	25	30	42	58	1,9
		D32-003-211	G 1 1/4	LH								
40	G 1 1/2	D40-003-210	G 1 1/2	RH	88	114	44	26	38	46	62	3,0
		D40-003-211	G 1 1/2	LH								

DEUBLIN

Rotating Union AP Series for Water or Hydraulic Oil Service, DN 8 - 25



- monoflow design
- self supported rotating union
- designed for high media pressure and high RPM
- seals made of Tungsten Carbide
- double row ball bearing, lubricated for life (excluding ZAP)
- vent holes
- steel housing
- stainless steel end cap and rotor
- all parts in media contact are stainless steel and corrosion resistant

Operating Data

Max. Hydraulic/Water Pressure*	5,800 PSI	400 bar
Max. Speed*	1,500 RPM	1.500 min ⁻¹
Max. Temperature	90 °C	> 90 °C consult DEUBLIN

* Operation at max. pressure combined with max. speed is not permissible

For further information please contact **DEUBLIN** or your local representative.

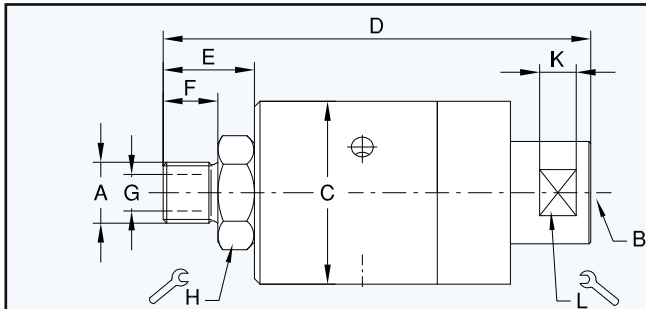

AP8 - AP12

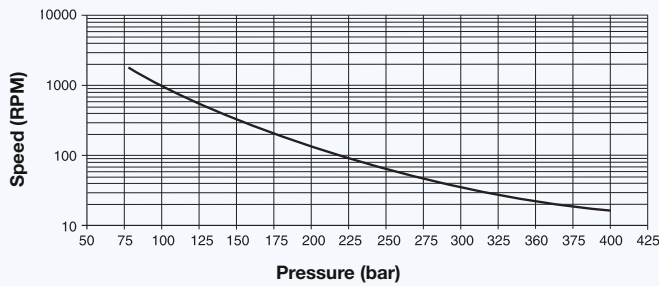

AP20 - AP25

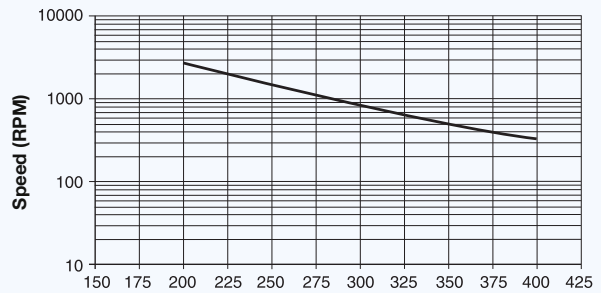

ZAP

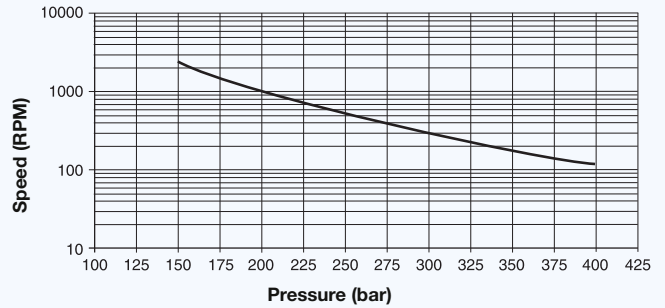

DN	B	Ordering No.	A Rotor Connections		C ∅	D	E	F	G ∅	H	K	L	kg
8	G 1/4	AP8-010-210	G 1/4 BSP	RH	50	117	25	15	7	27	10	25	0,8
		AP8-010-211	G 1/4 BSP	LH									
10	G 3/8	AP10-010-210	G 3/8 BSP	RH	50	117	25	15	10	27	10	25	0,8
		AP10-010-211	G 3/8 BSP	LH									
15	G 1/2	AP12-010-210	G 1/2 BSP	RH	50	122	30	20	12	27	10	25	1
		AP12-010-211	G 1/2 BSP	LH									
	G 1/2	ZAP-001-200	G 1/2 BSP	RH	74	132	30	15	11	30	10	25	2
		ZAP-001-201	G 1/2 BSP	LH									
20	G 3/4	AP20-001-200	G 3/4 BSP	RH	96	162,5	44	24	18	48	10	41	4,2
		AP20-001-201	G 3/4 BSP	LH									
25	G 1	AP25-001-200	G 1 BSP	RH	96	162,5	44	24	24	48	10	41	4,2
		AP25-001-201	G 1 BSP	LH									

DEUBLIN

Rotating Union 7100 Series for High Pressure Hydraulic Service, DN 8 - 20, Duoflow



- duoflow design
- self-supported rotating union
- hydrostatic bearing design
- wear-resistant bearing
- vent for controlled leakage, depending on pressure
- shaft seal for secondary sealing
- stainless steel housing
- hardened steel rotor

For further information please contact **DEUBLIN** or your local representative.

Operating Data

Max. Hydraulic Pressure	3,630 PSI	250 bar
Min. Hydraulic Pressure	40 PSI	3 bar
Max. Speed	500 RPM	500 min ⁻¹
Max. Temperature	60 °C	> 60 °C consult DEUBLIN
Required Oil Cleanliness: class 17/15/12, ISO 4406		

Customer's Shaft End

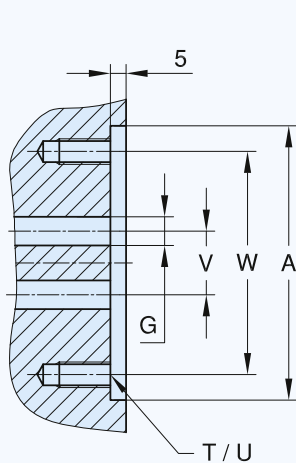

Flange Rotor

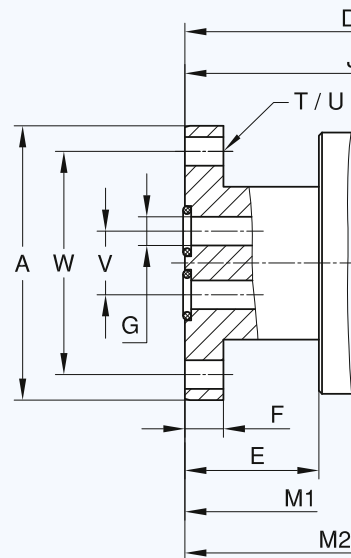

Threaded Rotor

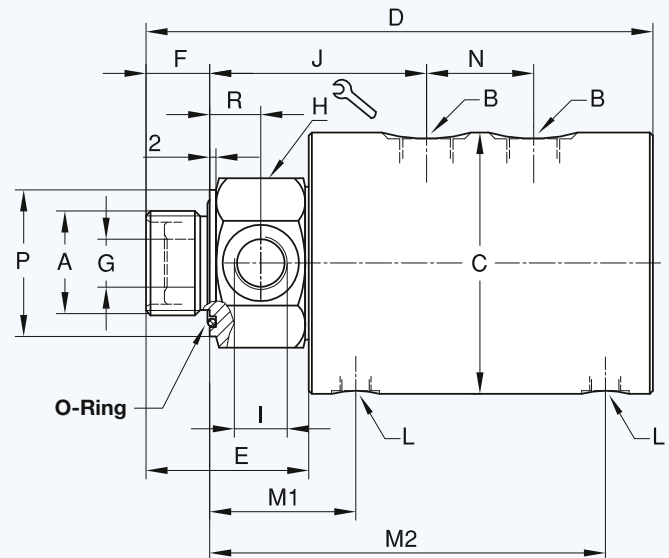

Duoflow Rotating Union

DN	B	Ordering No.	A Rotor Connections	C ∅	D	E	F	G ∅	H	I	J	L	M1/M2	N ∅	P ∅	R	T	U ∅	V ∅	W ∅	kg
2 x 8	2 x G 1/4	7100-773	G 3/4 RH	82	176	46	17	6,4	46	G 1/4	76	G 1/8	49,5/137,5	36	46	15	-	-	-	-	4,5
2 x 8	2 x G 1/4	7100-852	Flange ∅ 86 g6/H7	82	172	42	12	9	-	-	89	G 1/8	63/151	36	-	-	4x90°	9 M8	20	70	4,5
2 x 10	2 x G 3/8	7100-777	G 1 RH	82	181	51	20	8	46	G 3/8	78	G 1/8	52/140	36	46	16	-	-	-	-	4,4
2 x 10	2 x G 3/8	7100-853	Flange ∅ 86 g6/H7	82	172	42	12	9	-	-	89	G 1/8	63/151	36	-	-	4x90°	9 M8	20	70	4,4
2 x 15	2 x G 1/2	7100-711	G 1 1/4 RH	109	244	70	26	15	55	G 1/2	101	G 1/4	70,5/180,5	50	55	18	-	-	-	-	11
2 x 15	2 x G 1/2	7100-854	Flange ∅ 108 g6/H7	109	230	56	16	12,5	-	-	113	G 1/4	82,5/192,5	50	-	-	4x90°	11 M10	20,5	88	11
2 x 20	2 x G 3/4	7100-713	G 1 1/2 RH	109	249	75	28	17,5	65	G 3/4	106	G 1/4	73,5/183,5	50	65	20	-	-	-	-	12
2 x 20	2 x G 3/4	7100-855	Flange ∅ 148 g6/H7	148	288	78	25	19	-	-	153	2x G 1/2	110,5/253	60	-	-	6x60°	13,5 M12	33	126	28

DEUBLIN

Rotating Union

for Air, Hydraulic Oil, Brake Fluid and Vacuum Service, DN 8 and 15



Operating Data

Max. Air Pressure	150 PSI	10 bar
Max. Vacuum	2 "Hg	7 kPa
Max. Hydraulic Pressure*	3,050 PSI	210 bar
Max. Speed (short-term)*	250 RPM	250 min ⁻¹

Max. Temperature 120 °C > 120 °C consult DEUBLIN

* Operation at max. pressure combined with max. speed is not permissible

- monoflow and duoflow (Tandem) design
- self-supported rotating union
- no interpassage leakage on the duoflow design
- hardened sealing surface
- oilite bearing
- aluminium housing
- steel rotor
- optional models for swivel movements

For further information please contact **DEUBLIN** or your local representative.

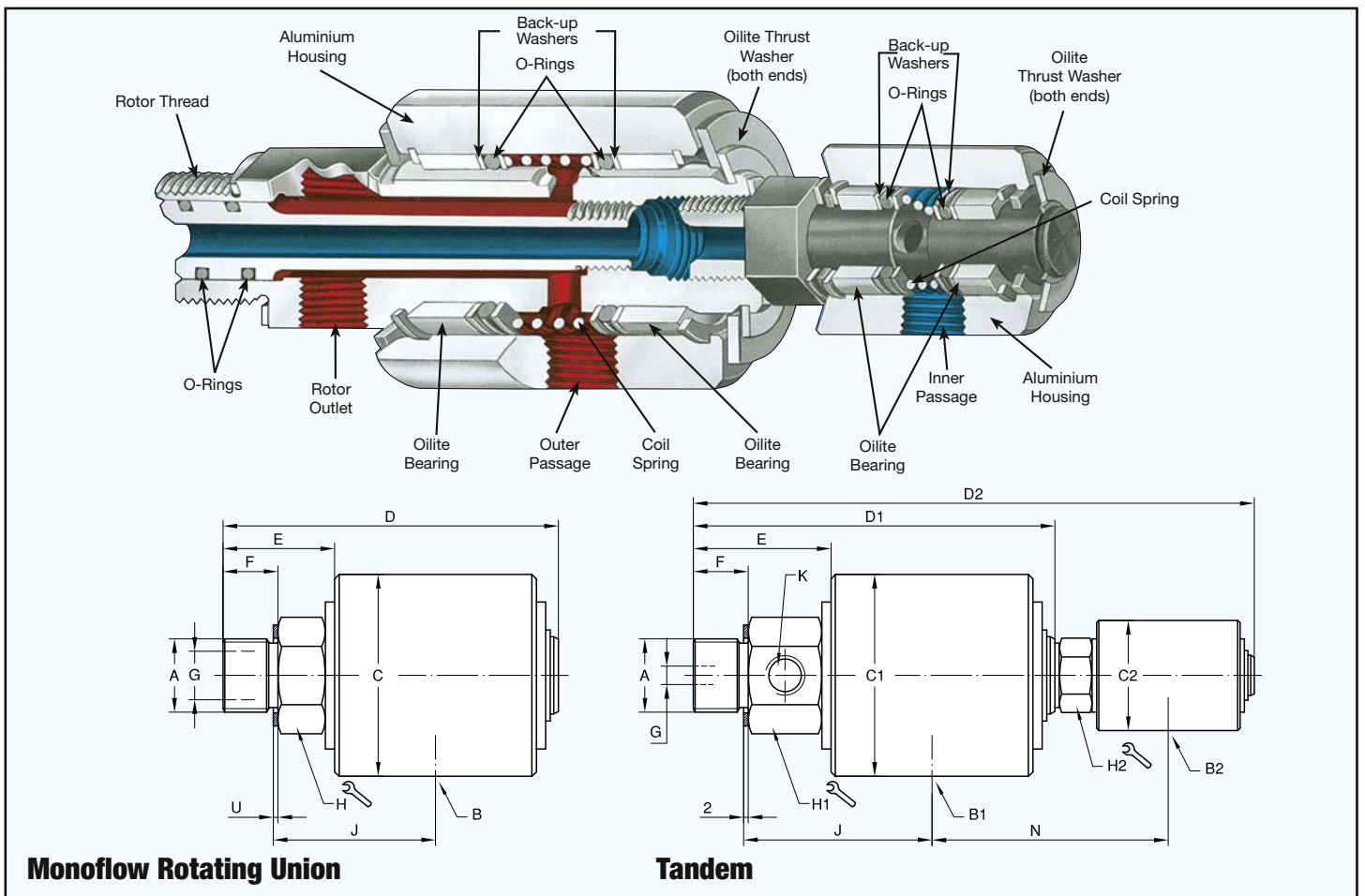

Monoflow Rotating Union

DN	B NPT	Ordering No.			A Rotor Connections	C ∅	D	E	F	G ∅	H	J	U	kg	
		Air/Hydraulic	Vacuum	Brake Fluid											
8	1/4	17-025-039	17-051-039	17-086-039	G 3/8	RH	38	83,3	29	16	8	22	39	1,5	0,3
	1/4	17-025-046	17-051-046	17-086-046	M16 x 2	RH	38	83,3	29	16	8	22	39	1,5	0,3
15	1/2	21-001-122	21-083-122	21-063-122	G 3/4	RH	70	116	39	19	16	36	57	2	1,2
	1/2	21-001-121	21-083-121	21-063-121	M22 x 1,5	RH	70	111	34	14	13	36	57	1,5	1,2

Duoflow Rotating Union (Tandem)

DN	B1 x B2 NPT	Ordering No.			A Rotor Connections	C1 ∅	C2 ∅	D1	D2	E	F	G ∅	H1	H2	J	K NPT	N	kg	
		Air/Hydraulic	Vacuum	Brake Fluid															
2 x 8	1/4 x 1/2	2117-001-105	2117-017-105	2117-018-137	G 3/4	RH	70	38	125	194	48	19	6,4	36	22	66	1/4	81	1,5

DEUBLIN

Rotating Union DEU-PLEX for Air and Hydraulic Service, DN 8 - 20

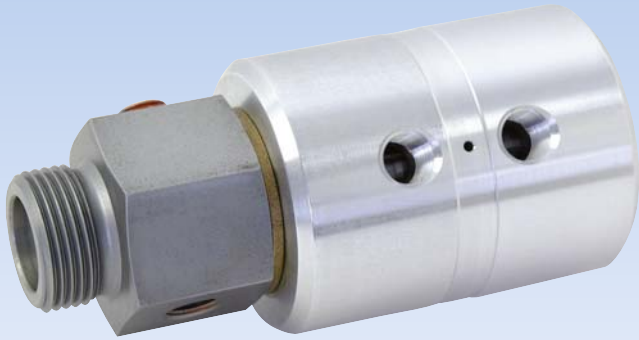

- duoflow design
- Tandem model as triple passage design
- self-supported rotating union
- composite bearing
- vent holes between passages
- carbon-filled teflon seals
- hardened sealing surface
- aluminium housing
- steel rotor

Operating Data

Max. Air Pressure	150 PSI	10 bar
Max. Vacuum	2 "Hg	7 kPa
Max. Hydraulic Pressure*	3,050 PSI	210 bar
Max. Speed (short-term)*	250 RPM	250 min ⁻¹
Max. Temperature	120 °C	> 120 °C consult DEUBLIN

* Operation at max. pressure combined with max. speed is not permissible

For further information please contact **DEUBLIN** or your local representative.

Additional models for high pressure hydraulic applications are available see catalogue page 55.

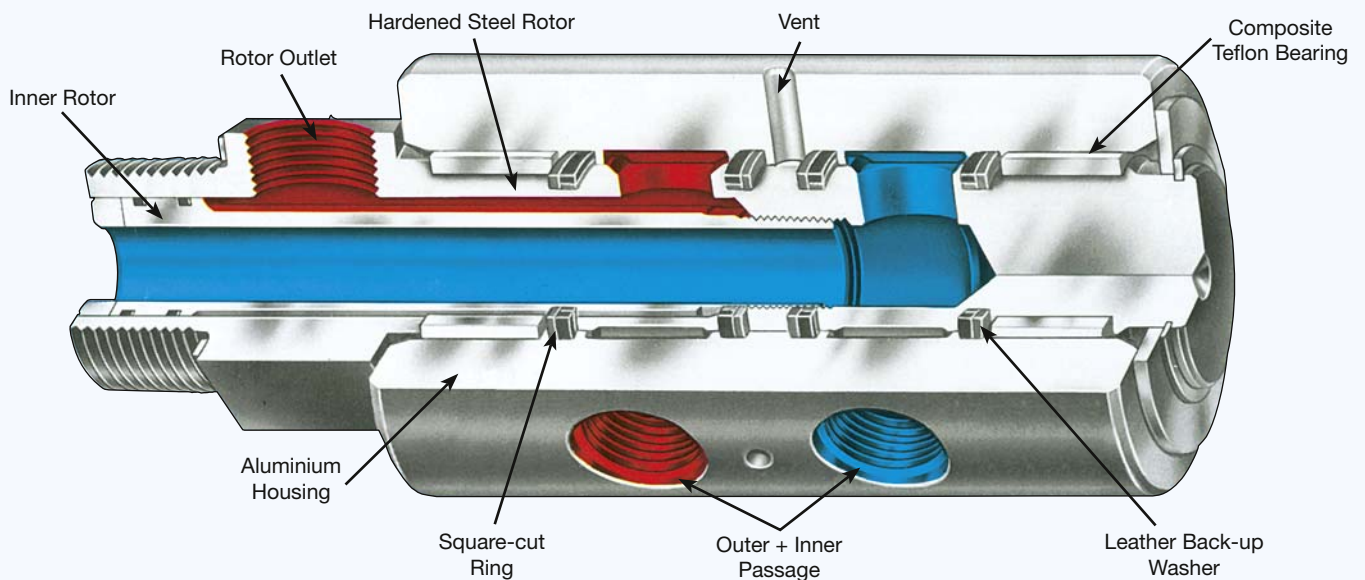

Models without inner rotors can be used for coaxial feed applications as shown below.

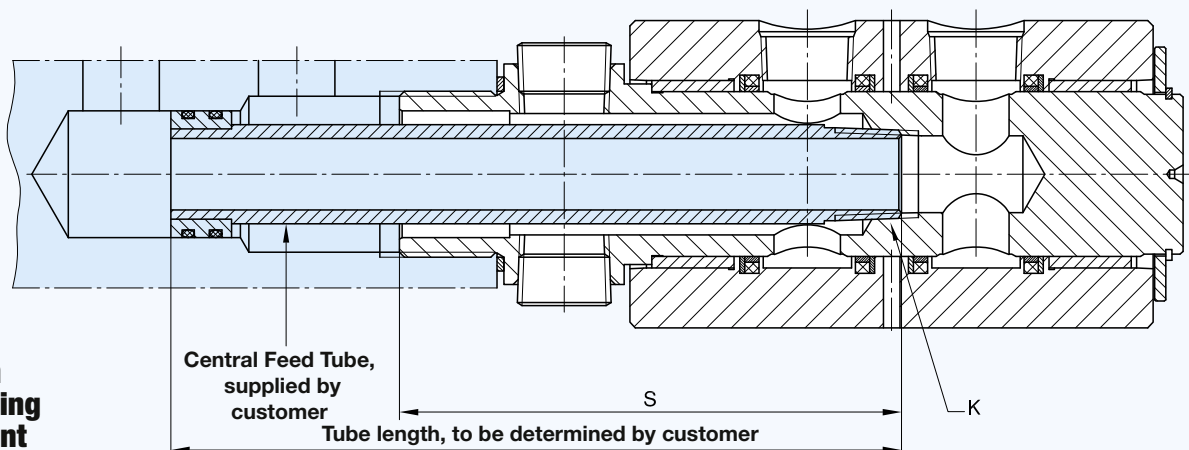
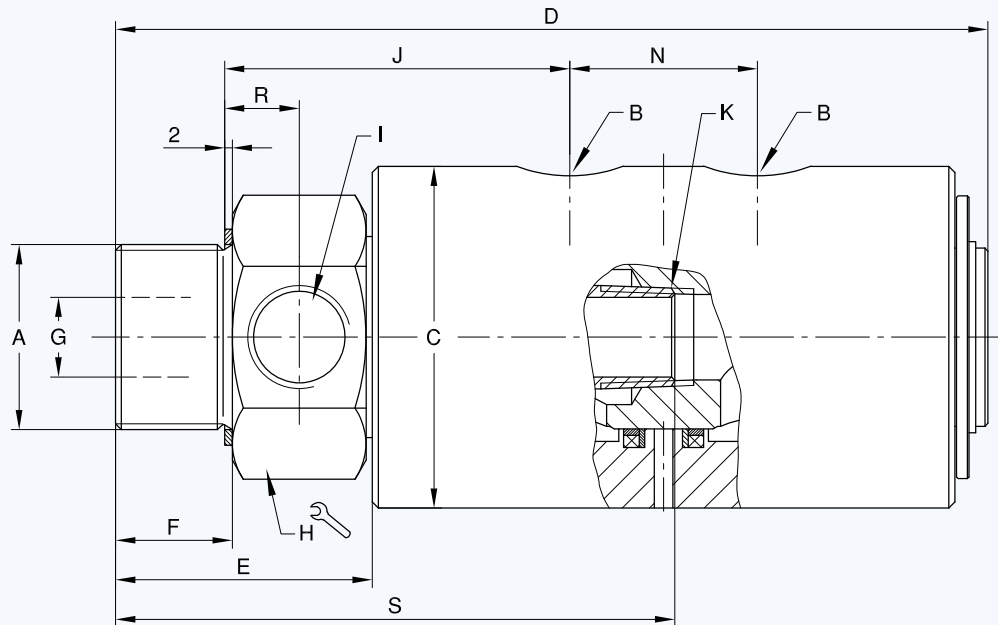

Illustration of a mounting arrangement

Duoflow Rotating Union



DN	B NPT	Ordering No.	A Rotor Connections	C ∅	D	E	F	G ∅	H	I NPT	J	K NPT	N	R	S	kg
2 x 8	2 x 1/4	1690-000-168	G 1 RH	66,4	150	55,5	18	8	46	1/4	68	1/4	29,5	19	-	1,6
	2 x 1/4	1690-000-105*	G 1 RH	66,4	150	55,5	18	17,5	46	1/4	68	1/4	29,5	19	97,4	1,6
2 x 15	2 x 1/2	1790-001-114	G 1 1/4 RH	76	208	63	28	16	55	1/2	85	1/2	42	18	-	3,1
	2 x 1/2	1790-001-112*	G 1 1/4 RH	76	208	63	28	27	55	1/2	85	1/2	42	18	133,2	3,1
2 x 20	2 x 3/4	1890-060	G 1 1/2 RH	88,5	226	66	30	20,6	65	3/4	89	3/4	49	19,5	-	4,4
	2 x 3/4	1890-063*	G 1 1/2 RH	88,5	226	66	30	34,9	65	3/4	89	3/4	49	19,5	149,4	4,2

* These models are delivered without inner rotors.

Triple Passage Rotating Union

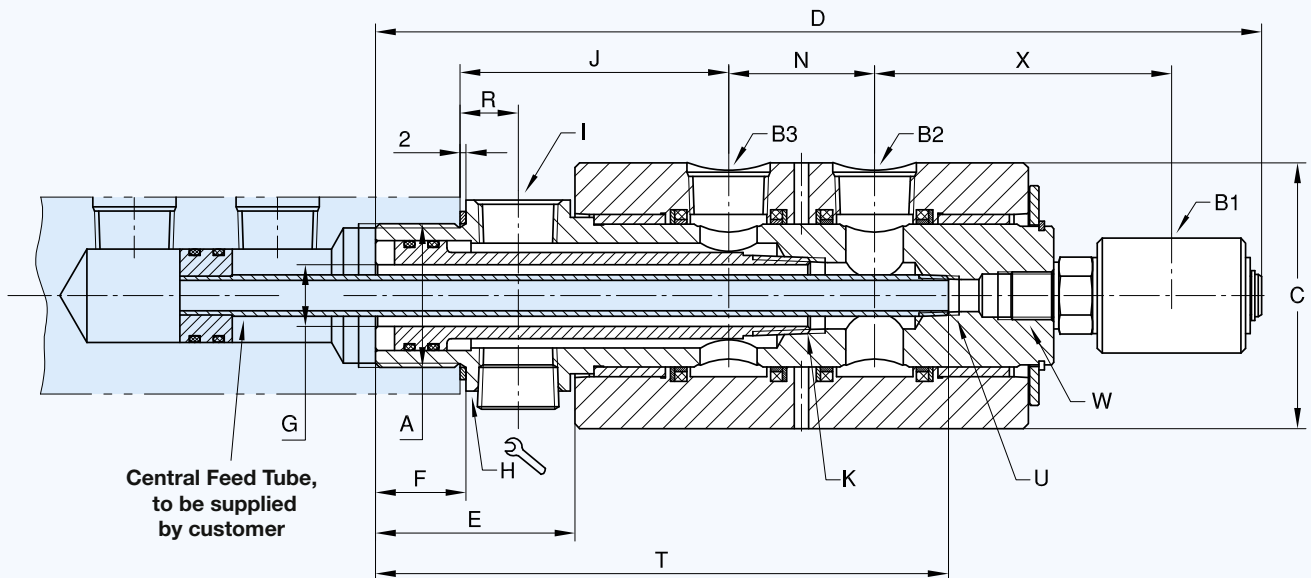

DN	B1 x B2 x B3 NPT	Ordering No.	A Rotor Connect.	C ∅	D	E	F	G ∅	H	I NPT	J	K NPT	N	R	T	U NPT	W	X	kg
8/15/20	1/4 x 3/4 x 3/4	1890-064	G 1 1/2 RH	88,5	293	67	30	20,6	65	3/4	89	3/4	48,5	19,5	190	1/4	5/8-18 UNF RH	98	4,7

DEUBLIN

Rotating Union 1379 and 1479 Series 4-Passage for Various Media



- Four independent passages for applications such as clamping and unclamping, work piece or tool sensing, and spindle cooling
- Vent between passages 2 and 3 allows use of two different media without cross contamination. For example, air in passages 1 and 2 and hydraulic oil in passages 3 and 4
- Stainless steel and brass components resist corrosion
- Hardened chrome sealing surface and elastomer-energized seals
- Dual, widely spaced ball bearings absorb large side loads

Operating Data

Max. Air Pressure	145 PSI	10 bar
Max. Hydraulic Pressure (rotating)	870 PSI	60 bar
Max. Hydraulic Pressure (very slow rotating)	3.626 PSI	250 bar
Max. Speed	250 RPM	250 min ⁻¹
Max. Flow per Passage		
1379 series	14 GPM	53 l/min
1479 series	28.5 GPM	108 l/min
Max. Temperature	80 °C	> 80 °C consult DEUBLIN
Filtration	ISO 4406 Class 17/15/12, max. 60 micron	

For further information please contact **DEUBLIN** or your local representative.

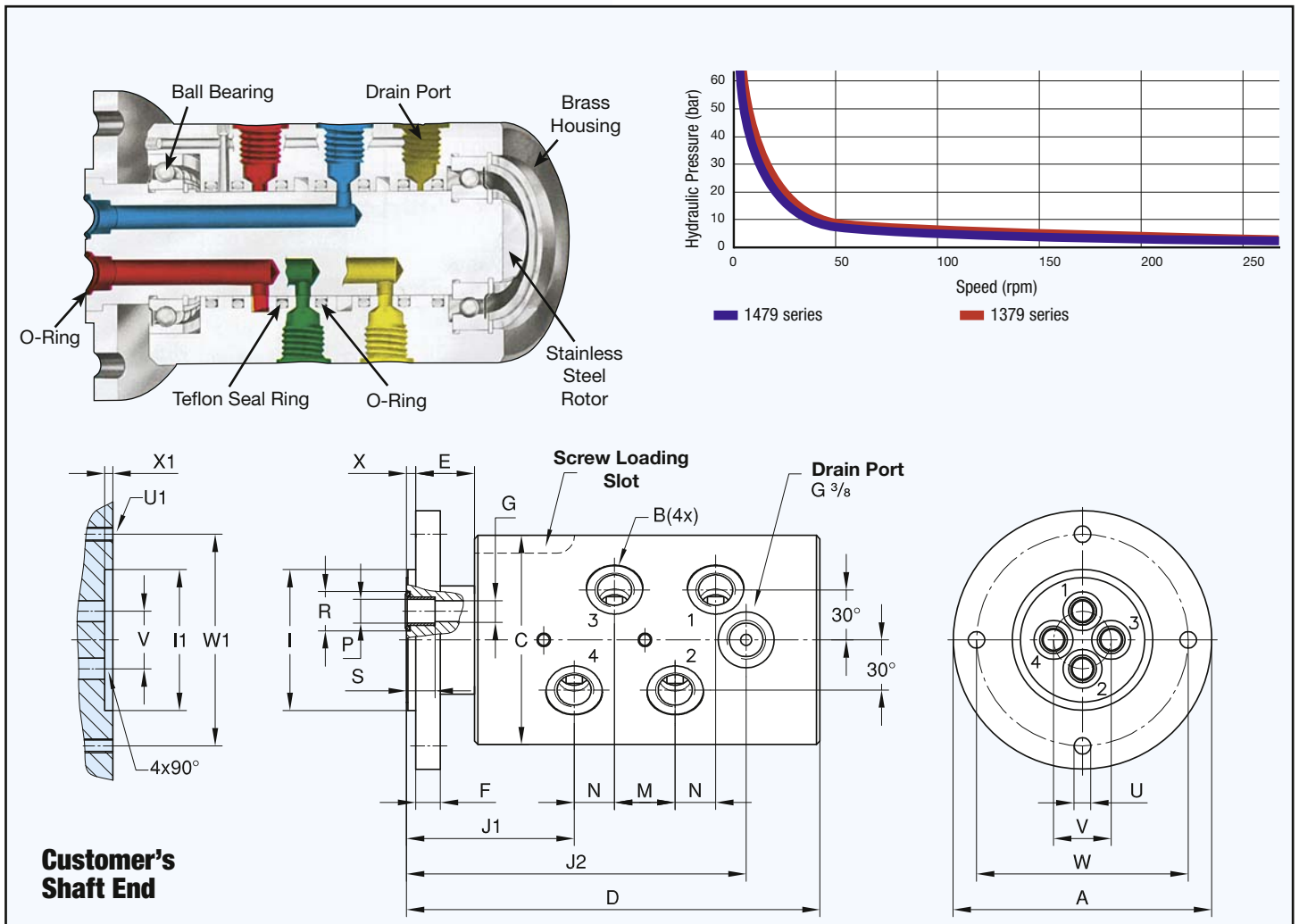

DN	B	Ordering No.	A ø	C ø	D	E	F	G ø	I ø PT	I1 ø PT	J1	J2	M	N	P ø	R ø	S	U ø	U1 ø	V ø	W ø	X	X1	W1 ø	kg
4x 10	4x G 3/8	1379-160	110	88	176	25	10,5	9	60,000 59,981	60,060 60,030	72	144,5	26	17	12,05 12,00	16,7	12	7,2	M6 4x90°	24,5	90	4	3,5	90	7,6
4x 10 + centr. pass.	4x G 3/8	1379-860	110	88	176	25	10,5	9	60,000 59,981	60,060 60,030	72	144,5	26	17	12,05 12,00	16,7	12	7,2	M6 4x90°	24,5	90	4	3,5	90	7,6
4x 15	4x G 1/2	1479-100	130	108	202	25	13,5	13	75,000 74,981	75,060 75,030	81	172	31	23	15,05 15,00	19,7	15	9	M8 4x90°	29	110	4	3,5	110	12,7
4x 15 + centr. pass.	4x G 1/2	1479-800	130	108	202	25	13,5	13	75,000 74,981	75,060 75,030	81	172	31	23	15,05 15,00	19,7	15	9	M8 4x90°	29	110	4	3,5	110	12,7

DEUBLIN

Rotating Union

DEU-PLEX for Air Service, DN 10



- duoflow design
- self-supported rotating union
- flange rotor
- radial housing connections
- low torque
- double-balanced mechanical seal
- full-media flow
- oiler for relubrication (3 - 5 drops/month)
- aluminium housing
- cast iron rotor
- Lubrication Guide page 52

For further information please contact **DEUBLIN** or your local representative.

Operating Data

Max. Air Pressure	150 PSI	10 bar
Max. Vacuum	2 "Hg	7 kPa
Max. Speed	1,500 RPM	1,500 min ⁻¹
Max. Temperature	120 °C	> 120 °C consult DEUBLIN

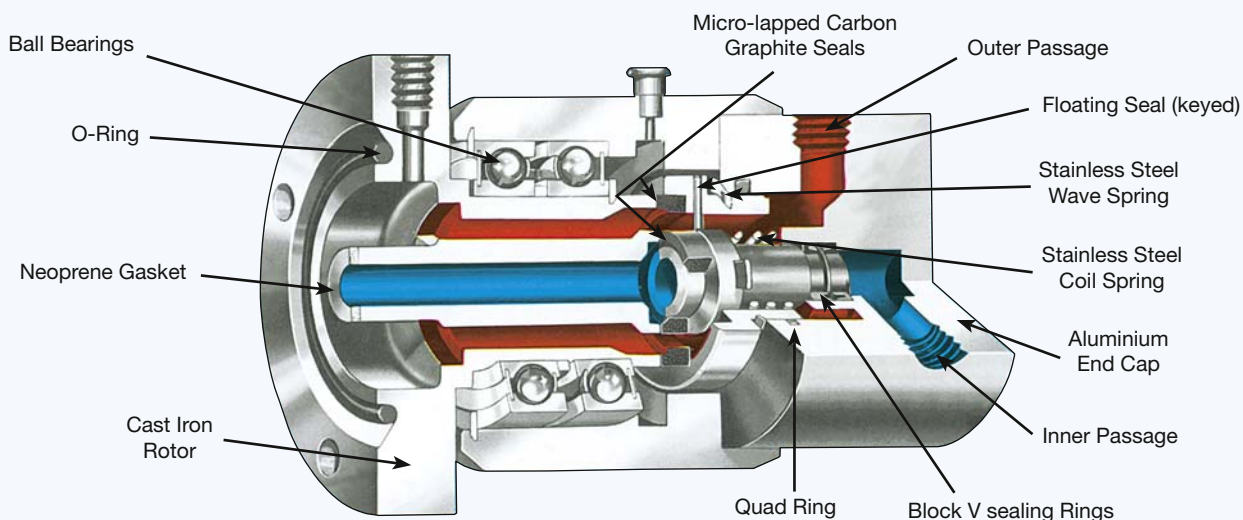

Customer's Shaft End

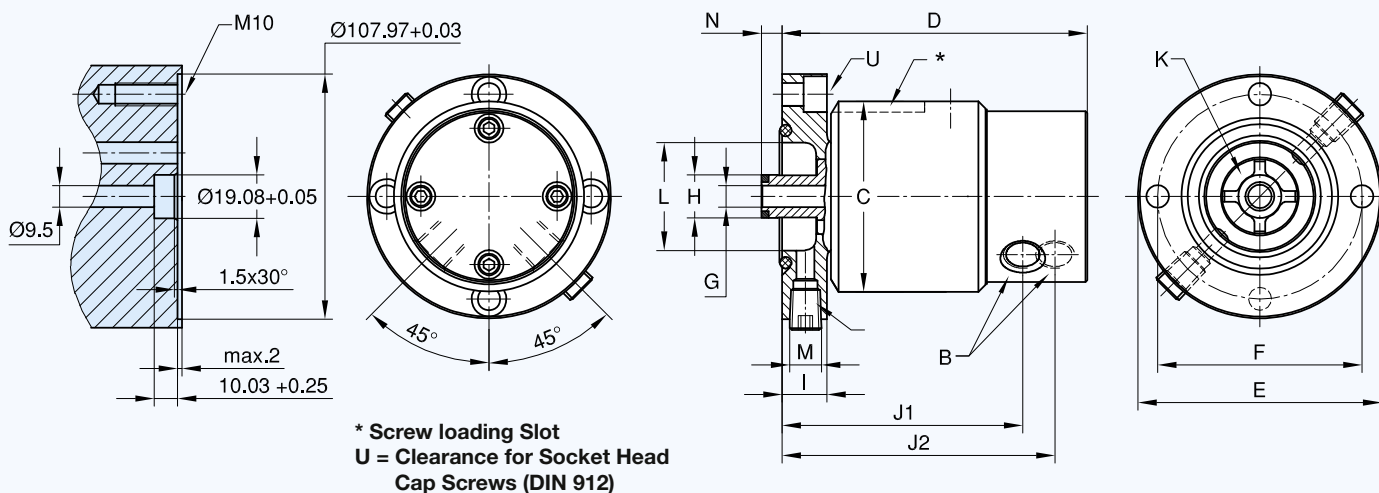

DN	B NPT	Ordering No.	C ø	D	E ø PT	F ø	G mm ²	H ø	I	J1	J2	K mm ²	L ø	M NPT	N	U Screws DIN 912	
2 x 10	2 x 3/8	1500-250	84	135	107,95 107,92	90,5	71	19,05 19,00	20	106	121	150	48	2 x 1/4	11,2	M10	3

DEUBLIN

Rotating Union

DEU-PLEX for Air and Hydraulic Oil Service, DN 15



- duoflow design
- self-supported rotating union
- radial and axial housing connections
- double-balanced mechanical seal
Carbon Graphite/Ceramic - standard,
Tungsten Carbide/Ceramic - E.L.S. (Extended Life Sealing)
- full-media flow
- oiler for relubrication (3 - 5 drops/month)
- aluminium housing
- cast iron flange rotor
- Lubrication Guide page 52

Operating Data

Max. Air Pressure (1590)	150 PSI	10 bar
Max. Hydraulic Pressure* (1579)		
outer passage	510 PSI	35 bar
inner passage	1,020 PSI	70 bar
Max. Speed*	1,500 RPM	1.500 min ⁻¹
Max. Temperature	120 °C	> 120 °C consult DEUBLIN

* Operation at max. pressure combined with max. speed is not permissible
For the higher pressure use inner passage only

For further information please contact **DEUBLIN** or your local representative.

Typical Adapter Mounting Arrangement

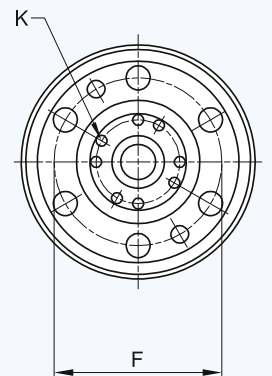
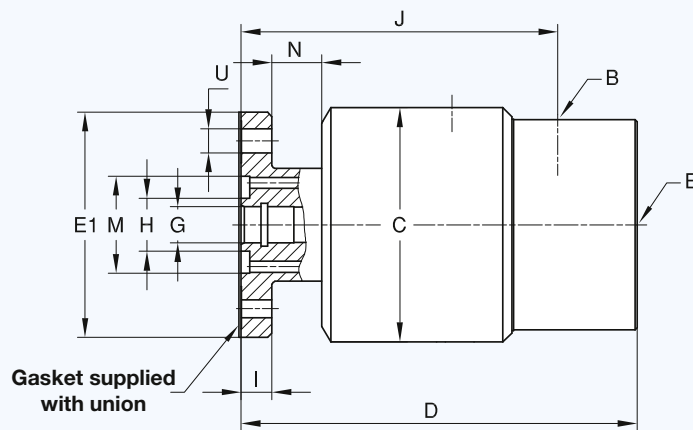
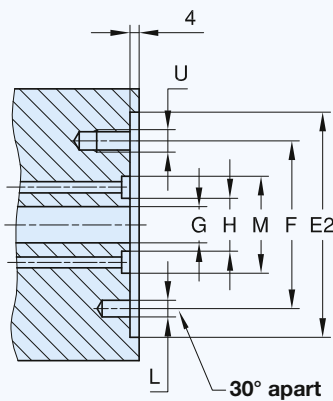
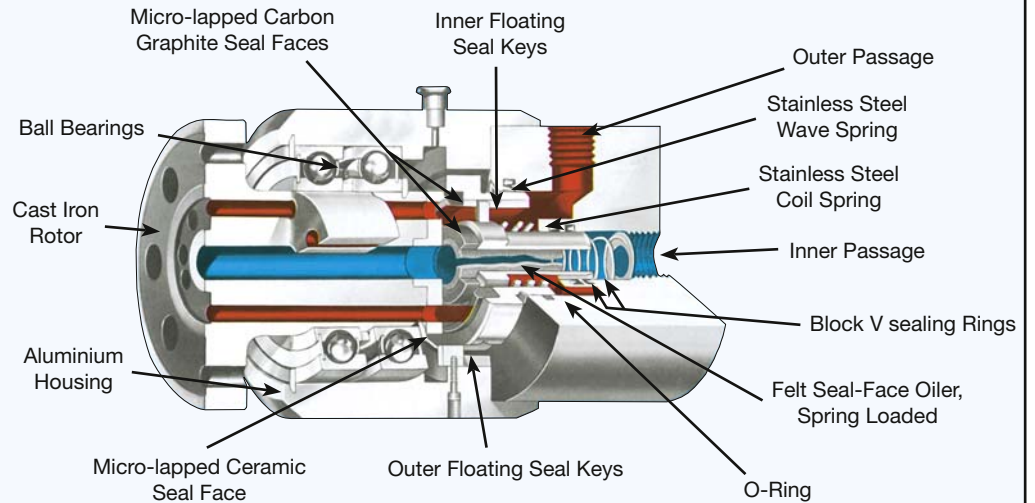
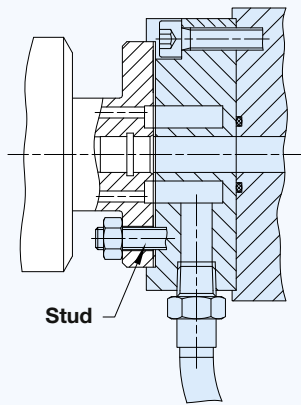

DN	B NPT	Ordering No.	Media	C ∅	D ∅	E1 ∅ PT	E2 ∅	F ∅	G mm ²	H ∅	I ∅	J	K mm ²	L Dowel Pin ∅	M ∅	N ∅	U ∅	kg
2x 15	2 x 1/2	1590-000 STD	Air	84	143	81,000 80,985	81,050 81,020	60,3	126	19	11	114	100	6	35	19	8,7 M8	2,5
	2 x 1/2	1579-000 STD	Hydraulic Oil	84	143	81,000 80,985	81,050 81,020	60,3	126	19	11	114	100	6	35	19	8,7 M8	2,5
	2 x 1/2	1579-074 ELS	Hydraulic Oil	96	142	81,000 80,985	81,050 81,020	60,3	126	19	11	113	100	6	35	12	8,7 M8	3,1

DEUBLIN

2620 Series 2-Passage Rotating Unions for Various Media

- Two independent passages for applications such as clamping and unclamping
- Balanced mechanical seals for each passage provide long life and reduced torque even at maximum pressure
- Closed seals provide continuous containment of media
- Dual precision ball bearings for smooth operation
- Labyrinth protection for ball bearings
- Mountings options are compatible with *DEUBLIN* 2520 or 1579 series unions



Operating Data

Max. Pressure	see chart/table	
Max. Flow (per passage)	18.2 GPM	69 l/min
Max. Speed	7,000 RPM	7,000 min ⁻¹
Max. Temperature	71 °C	> 71 °C consult DEUBLIN
Filterung	ISO 4406 Class 17/15/12, max. 60 micron	

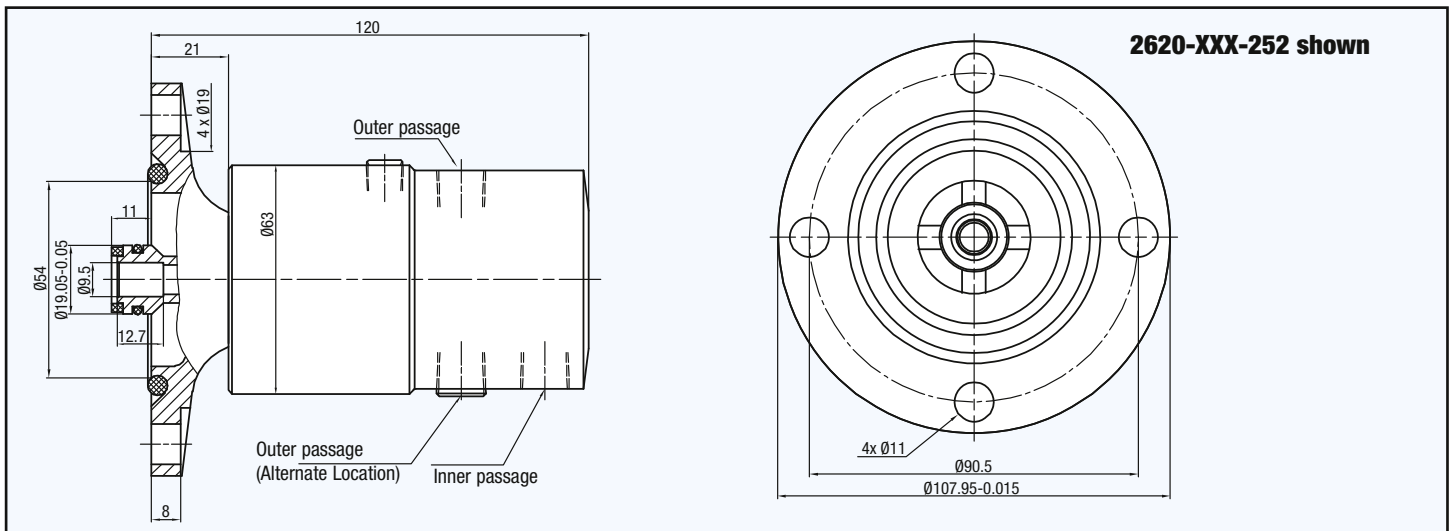
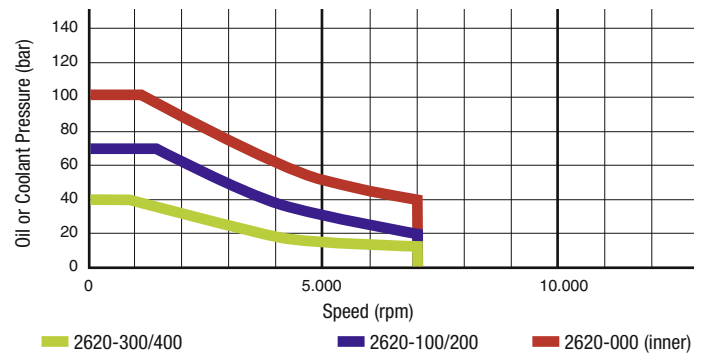

With Ø 108 mm flanged rotor		With Ø 88 mm flanged rotor		With Ø 81 mm flanged rotor		Inner Passage		Outer Passage		Notes	
Ordering Number	Supply Connections	Ordering Number	Supply Connections	Ordering Number	Supply Connections	Media	Max. Pressure [bar]	Media	Max. Pressure [bar]		
	Inner and outer Passage		Inner Passage		Outer Passage					Inner and outer Passage	
2620-000-252	1/4 NPT	2620-002-940	G 1/4	G 1/4	2620-000-157	1/4 NPT	Hydraulic oil	100	Hydraulic oil	30	
2620-100-252	1/4 NPT	2620-102-940	G 3/8	G 1/8	2620-100-157	1/4 NPT	Hydraulic oil	70	Air	6	Air seals may be lubricated through oil cup or by using oiled air.
2620-120-252	1/4 NPT	2620-122-940	G 3/8	G 1/8	2620-120-157	1/4 NPT	Hydraulic oil	70	Air	10	
2620-200-252	1/4 NPT	2620-202-940	G 3/8	G 1/8	2620-200-157	1/4 NPT	Coolant	70	Air	6	
2620-220-252	1/4 NPT	2620-222-940	G 3/8	G 1/8	2620-220-157	1/4 NPT	Coolant	70	Air	10	
2620-300-252	1/4 NPT	2620-302-940	G 1/4	G 1/4	2620-300-157	1/4 NPT	Air	6	Hydraulic oil	40	
2620-320-252	1/4 NPT	2620-322-940	G 1/4	G 1/4	2620-320-157	1/4 NPT	Air	10	Hydraulic oil	40	
2620-400-252	1/4 NPT	2620-402-940	G 1/4	G 1/4	2620-400-157	1/4 NPT	Air	6	Coolant	40	
2620-420-252	1/4 NPT	2620-422-940	G 1/4	G 1/4	2620-420-157	1/4 NPT	Air	10	Coolant	40	
2620-500-252	1/4 NPT	2620-502-940	G 3/8	G 1/8	2620-500-157	1/4 NPT	Air	6	Air	6	Consult <i>DEUBLIN</i> regarding maximum speed.
2620-520-252	1/4 NPT	2620-522-940	G 3/8	G 1/8	2620-520-157	1/4 NPT	Air	10	Air	10	

DEUBLIN

2620 Series 2-Passage Rotating Unions for Various Media

- Two independent passages for applications such as clamping and unclamping, work piece sensing, and cooling
- Balanced mechanical seals for each passage provide long life and reduced torque even at maximum pressure
- Closed seals provide continuous containment of media
- Dual precision ball bearings for smooth operation
- Labyrinth protection for ball bearings
- Mountings options are compatible with DEUBLIN 2520 or 1579 series unions

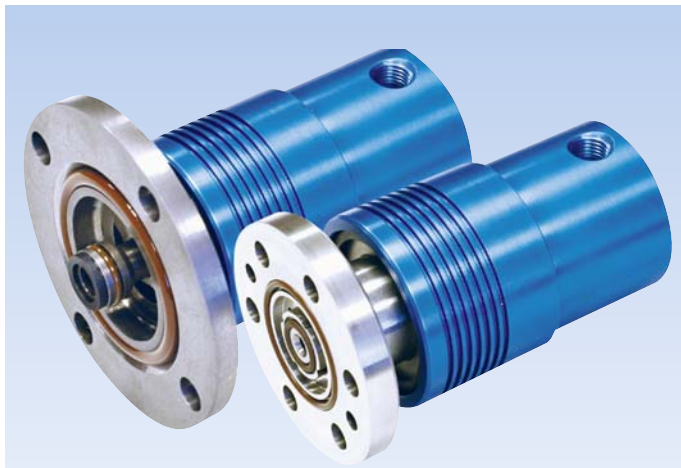

Operating Data

Max. Pressure	see chart/table	
Max. Speed*	12,000 RPM	12,000 min ⁻¹
Max. Flow Rate (per passage)	18.2 GPM	69 l/min
Max. Temperature	71 °C	> 71 °C consult DEUBLIN
Filtration	ISO 4406 Class 17/15/12, max. 60 micron	

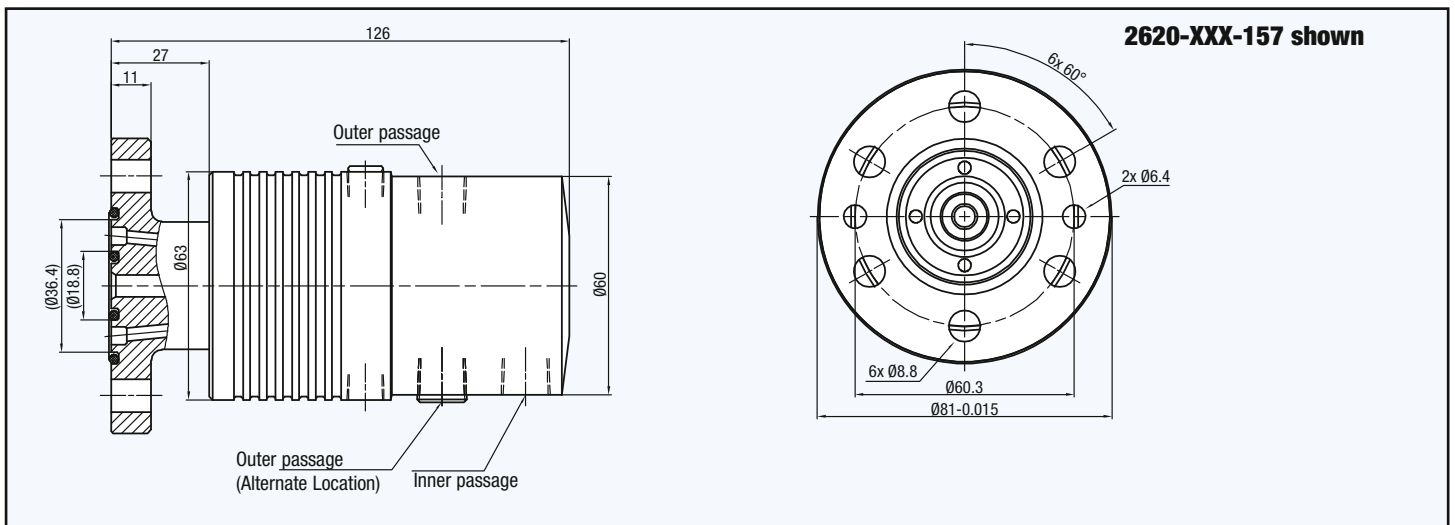
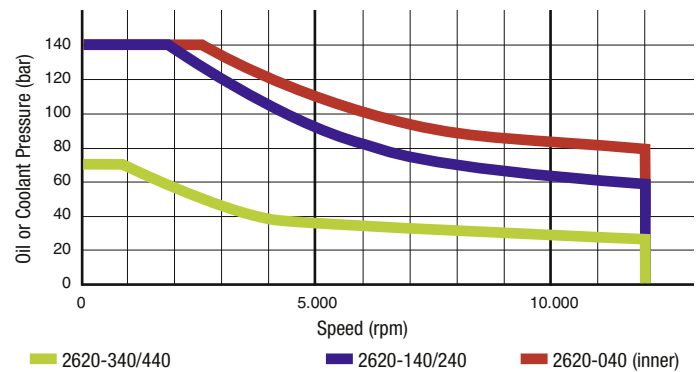

With Ø 108 mm flanged rotor		With Ø 88 mm flanged rotor		With Ø 81 mm flanged rotor		Inner Passage		Outer Passage		Notes	
Ordering Number	Supply Connections	Ordering Number	Supply Connections		Ordering Number	Supply Connections		Media	Max. Pressure [bar]		Media
	Inner and outer Passage		Inner Passage	Outer Passage		Inner and outer Passage	Inner Passage			Outer Passage	
2620-040-252	1/4 NPT	2620-042-940	G 1/4	G 1/4	2620-040-157	1/4 NPT	Hydraulic oil	140	Hydraulic oil	70	
2620-140-252	1/4 NPT	2620-142-940	G 3/8	G 1/8	2620-140-157	1/4 NPT	Hydraulic oil	140	Air	6	Air seals may be lubricated through oil cup or by using oiled air.
2620-160-252	1/4 NPT	2620-162-940	G 3/8	G 1/8	2620-160-157	1/4 NPT	Hydraulic oil	140	Air	10	
2620-240-252	1/4 NPT	2620-242-940	G 3/8	G 1/8	2620-240-157	1/4 NPT	Coolant	140	Air	6	
2620-260-252	1/4 NPT	2620-262-940	G 3/8	G 1/8	2620-260-157	1/4 NPT	Coolant	140	Air	10	
2620-340-252	1/4 NPT	2620-342-940	G 1/4	G 1/4	2620-340-157	1/4 NPT	Air	6	Hydraulic oil	70	Air seals require no external lubrication.
2620-360-252	1/4 NPT	2620-362-940	G 1/4	G 1/4	2620-360-157	1/4 NPT	Air	10	Hydraulic oil	70	
2620-440-252	1/4 NPT	2620-442-940	G 1/4	G 1/4	2620-440-157	1/4 NPT	Air	6	Coolant	70	
2620-460-252	1/4 NPT	2620-462-940	G 1/4	G 1/4	2620-460-157	1/4 NPT	Air	10	Coolant	70	



DEUBLIN

1116 Series "Closed Seal" Rotating Unions for Continuous Coolant Service

- Single passage for coolant or MQL
- Closed seals for transfer line and similar applications
- Full-flow design has no obstructions to trap swarf or debris
- Bearing-supported with threaded rotor for easy installation
- Deep groove radial ball bearings for smooth operation
- Labyrinth system and large vents to protect ball bearings
- Balanced mechanical seals made from silicon carbide for long life even under difficult operating conditions
- Anodised aluminium housing resists corrosion

Operating Data

Max. Pressure			
Water-based Coolant	1,015 PSI	70 bar	
MQL (oil mist)	145 PSI	10 bar	
Max. Speed	12,000 RPM	12.000 min ⁻¹	
Max. Flow Rate	21.6 GPM	82 l/min	
Max. Temperature	71 °C	> 71 °C consult DEUBLIN	
Filtration	ISO 4406 Class 17/15/12, max. 60 micron		



DO NOT RUN DRY

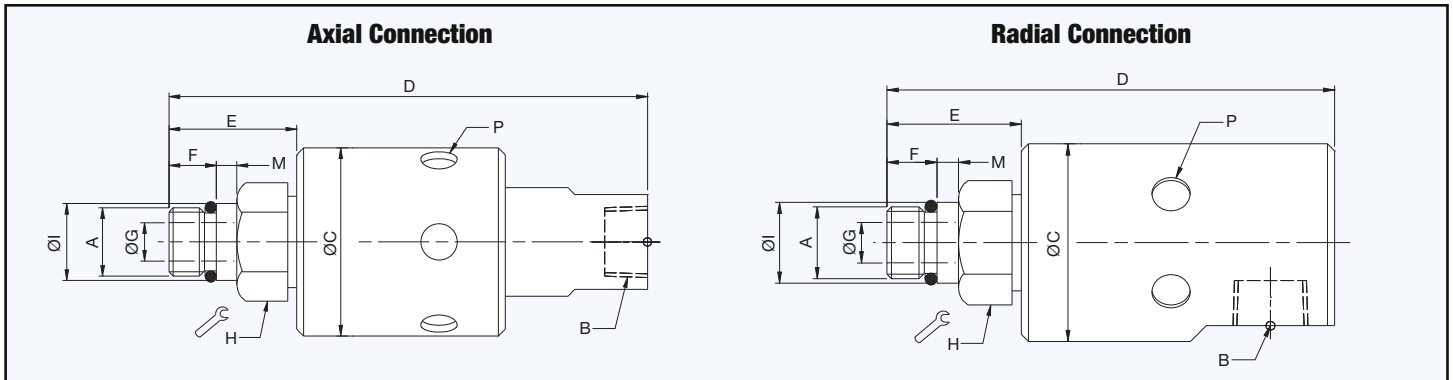
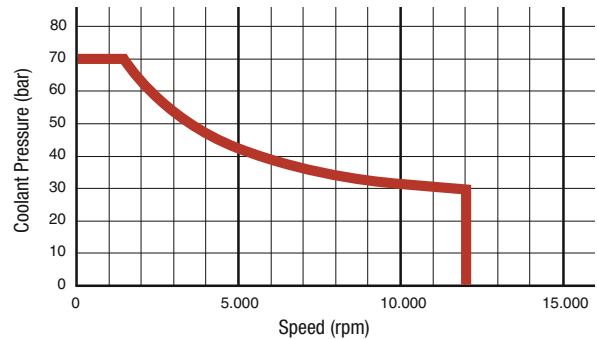

	Ordering Number	B Supply Connection	C Overall Diameter	D Overall Length	P Vent Size Ø (6 x 60°)	A Rotor Connection	E Rotor Length	F Thread Length	G Bore Diameter	H Across Flats	I Pilot Diameter	M Pilot Length
Axial Connection	1116-048-064	1/4 NPT	44	115	9	5/8-18 UNF RH	33	14	9	15/16"	0.6555" / 0.6553"	5
	1116-048-463	1/4 NPT	44	112	9	M16 x 1.5 LH	30	11	9	24	17.993 / 17.988	5
	1116-485-463	G 1/4	44	112	9	M16 x 1.5 LH	30	11	9	24	17.993 / 17.988	5
	1116-580-343	3/8 PT	44	112	9	M12 x 1.25 LH	30	11	6	24	13.994 / 13.989	5
	1116-600-059	3/8 NPT	44	115	9	5/8-18 UNF LH	33	14	9	15/16"	0.6555" / 0.6550"	5
	1116-600-463	3/8 NPT	44	112	9	M16 x 1.5 LH	30	11	9	24	17.993 / 17.988	5
	1116-610-463	G 3/8	44	112	9	M16 x 1.5 LH	30	11	9	24	17.993 / 17.988	5
Radial Connection	1116-090-059	3/8 NPT	44	106	9	5/8-18 UNF LH	33	14	9	15/16"	0.6555" / 0.6553"	5
	1116-090-064	3/8 NPT	44	106	9	5/8-18 UNF RH	33	14	9	15/16"	0.6555" / 0.6553"	5
	1116-090-463	3/8 NPT	44	103	9	M16 x 1.5 LH	30	11	9	24	17.993 / 17.988	5
	1116-516-463*	G 3/8	44	102	9	M16 x 1.5 LH	29	11	9	24	17.993 / 17.988	5
	1116-555-463	G 3/8	44	102	9	M16 x 1.5 LH	29	11	9	24	17.993 / 17.988	5

* Also suitable for Cutting Oil and Air by reduced operating data. For further information please contact DEUBLIN.

DEUBLIN

1101 Series "Closed Seal" Rotating Unions for Continuous Coolant Service



Operating Data

Max. Pressure		
Water-based Coolant	1,523 PSI	105 bar
MQL (oil mist)	145 PSI	10 bar
Max. Speed	15,000 RPM	15,000 min ⁻¹
Max. Flow Rate	5.3 GPM	20 l/min
Max. Temperature	71 °C	> 71 °C consult DEUBLIN
Filtration	ISO 4406 Class 17/15/12, max. 60 micron	

- Single passage for coolant or MQL
- Closed seals for transfer line and similar applications
- Full-flow design has no obstructions to trap swarf or debris
- Bearing-supported with threaded rotor for easy installation
- Deep groove radial ball bearings for smooth operation
- Labyrinth system and large vents to protect ball bearings
- Balanced mechanical seals made from silicon carbide for long life even under difficult operating conditions
- Anodised aluminium components resist corrosion

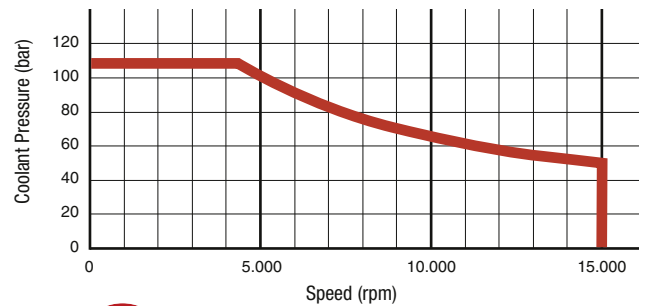

DO NOT RUN DRY

Axial Connection

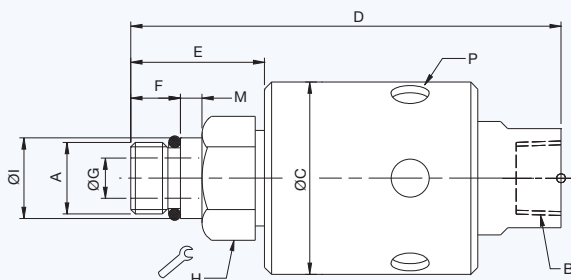

Radial Connection

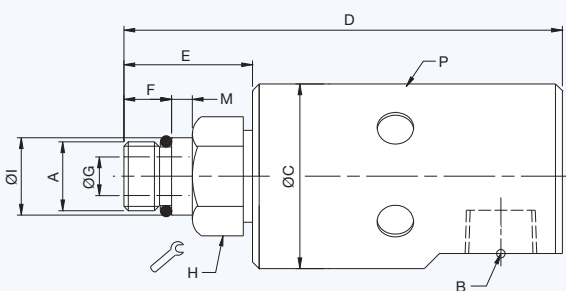

Bore Mounted

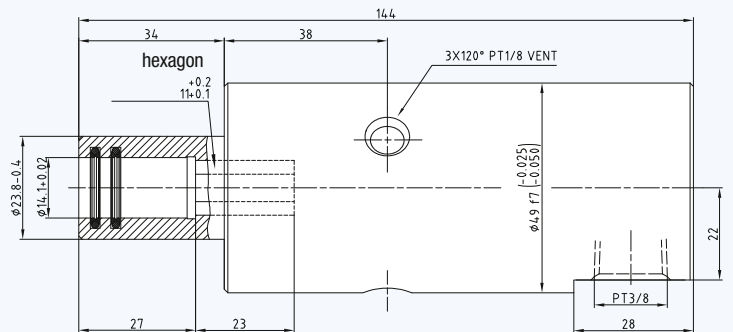

	Ordering Number	B Supply Connection	C Overall Diameter	D Overall Length	P Vent Size Ø (6 x 60°)	A Rotor Connection	E Rotor Length	F Thread Length	G Bore Diameter	H Across Flats	I Pilot Diameter	M Pilot Length
Axial Connection	1101-235-238	3/8 NPT	43	100	9	5/8-18 UNF LH	33	14	6	15/16"	0.6555" / 0.6553"	5
	1101-235-239	3/8 NPT	43	100	9	5/8-18 UNF RH	33	14	6	15/16"	0.6555" / 0.6553"	5
	1101-235-343	3/8 NPT	43	97	9	M16 x 1.5 LH	30	11	6	24	17.993 / 17.988	5
	1101-235-424	3/8 NPT	43	93	9	M10 x 1 LH	27	11	3.2	24	10.994 / 10.989	3
	1101-359-343	G 3/8	43	102	9	M16 x 1.5 LH	30	11	6	24	17.993 / 17.988	5
	1101-620-343	3/8 NPT	43	96	9	M16 x 1.5 LH	30	11	6	24	17.993 / 17.988	5
Radial	1101-195-343	G 3/8	43	97	9	M16 x 1.5 LH	30	11	6	24	17.993 / 17.988	5
	1101-615-598 ^A	3/8 PT	49	143,5	3 x 1/8 PT	14 mm female hex	34	-	6	-	14.122 / 14.097	27

Note A: Bore-mounted design.

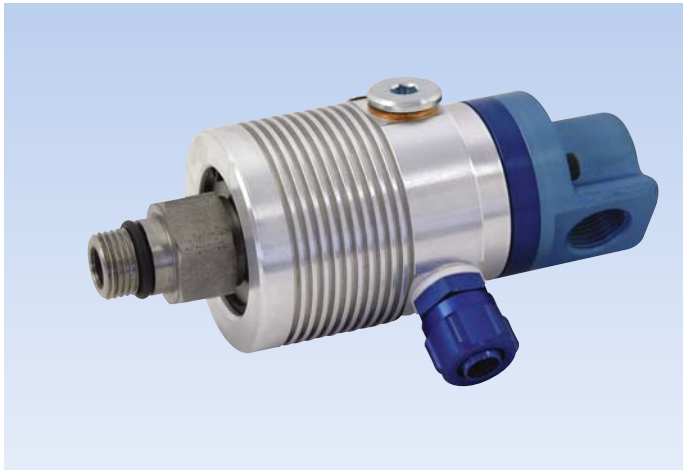

DEUBLIN

1109 Series Pop-Off™

Rotor-Mounted Rotating Unions for Coolant Service with Dry Running

- Single passage for coolant or MQL
- Patented Pop-Off™ technology allows unlimited dry running without media pressure
- Full-flow design has no obstructions to trap swarf or debris
- Bearing-supported with threaded rotor for easy installation
- Dual ABEC 7 (ISO class P4) angular contact ball bearings
- Labyrinth system and large vents to protect ball bearings
- Balanced mechanical seals made from silicon carbide for long life even under difficult operating conditions
- Aluminium housing, endcap anodised resists corrosion

Operating Data

Max. Pressure	see chart	
Water-based Coolant	145 PSI	10 bar
MQL (oil mist)	20,000 RPM	20,000 min ⁻¹
Max. Speed	21.6 GPM	82 l/min
Max. Flow Rate	Standard	High Pressure
	6.4 GPM	24,3 l/min
Max. Temperature	71 °C	> 71 °C consult DEUBLIN
Filtration	ISO 4406 Class 17/15/12, max. 60 micron	



NO AIR PRESSURE WITH ROTATION

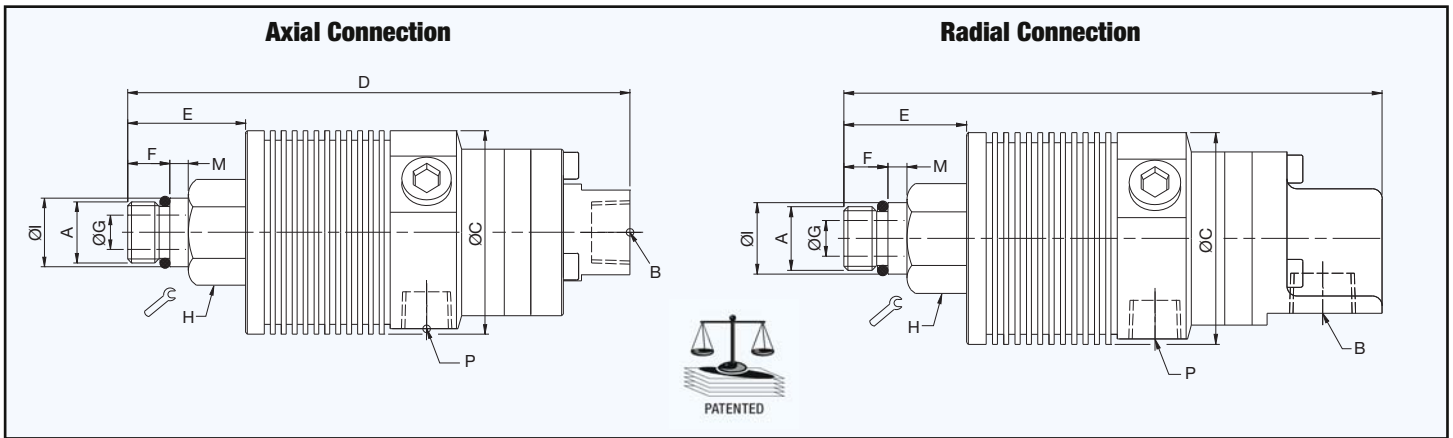
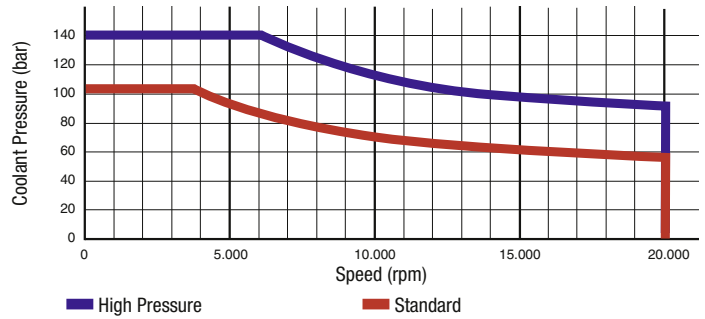

	Ordering Number	B Supply Connection	C Overall Diameter	D Overall Length	P Drain Size Ø (3 x 120°)	A Rotor Connection	E Rotor Length	F Thread Length	G Bore Diameter	H Across Flats	I Pilot Diameter	M Pilot Length
Standard	1109-011-165	3/8 NPT Axial	53	132	1/4 NPT	5/8-18 UNF LH	34	14	9	15/16"	0.6555" / 0.6553"	5
	1109-021-188	G 3/8 Axial	53	129	G 1/4	M16 x 1.5 LH	31	11	9	24	17.993 / 17.988	5
	1109-041-188	3/8 PT Axial	53	129	1/4 PT	M16 x 1.5 LH	31	11	9	24	17.993 / 17.988	5
	1109-010-165	3/8 NPT Radial	53	138	1/4 NPT	5/8-18 UNF LH	34	14	9	15/16"	0.6555" / 0.6553"	5
	1109-020-188	G 3/8 Radial	53	135	G 1/4	M16 x 1.5 LH	31	11	9	24	17.993 / 17.988	5
	1109-040-188	3/8 PT Radial	53	135	1/4 PT	M16 x 1.5 LH	31	11	9	24	17.993 / 17.988	5
High Pressure	1109-014-196	1/4 NPT Axial	53	132	1/4 NPT	5/8-18 UNF LH	34	14	9	15/16"	0.6555" / 0.6553"	5
	1109-024-212	G 1/4 Axial	53	129	G 1/4	M16 x 1.5 LH	31	11	9	24	17.993 / 17.988	5
	1109-044-212	1/4 PT Axial	53	129	1/4 PT	M16 x 1.5 LH	31	11	9	24	17.993 / 17.988	5
	1109-013-196	1/4 NPT Radial	53	138	1/4 NPT	5/8-18 UNF LH	34	14	9	15/16"	0.6555" / 0.6553"	5
	1109-023-212	G 1/4 Radial	53	135	G 1/4	M16 x 1.5 LH	31	11	9	24	17.993 / 17.988	5
	1109-043-212	1/4 PT Radial	53	135	1/4 PT	M16 x 1.5 LH	31	11	9	24	17.993 / 17.988	5

DEUBLIN

Rotating Union 2400 Series for Water Service at Continuous Casting Steel Plants, DN 20 - 40



Operating Data

Max. Water Pressure	150 PSI	10 bar
Max. Speed	100 RPM	100 min ⁻¹
Max. Temperature	120 °C	> 120 °C consult DEUBLIN

- monoflow and duoflow design
- in-the-shaft mounted rotating union
- flanged housing or mounted with retaining plates
- high-wear resistant balanced mechanical seal Silicon Carbide/Silicon Carbide
- brass housings and elbows
- stainless steel rotors and supply pipes
- for poor water quality
- long composite bearing
- bearing protected by O-ring
- full-media flow

For further information please contact **DEUBLIN** or your local representative.

Monoflow Rotating Union

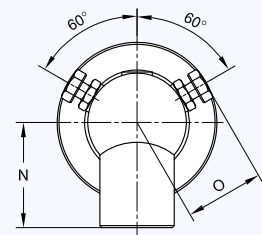
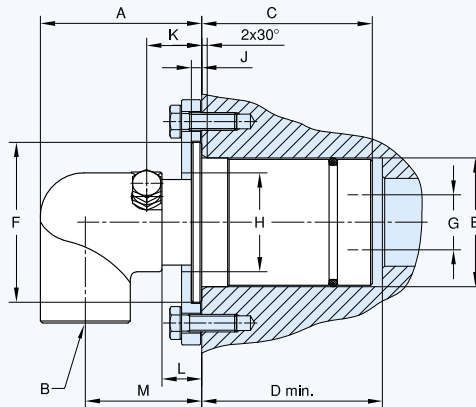

Duoflow Rotating Union

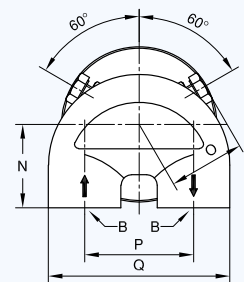
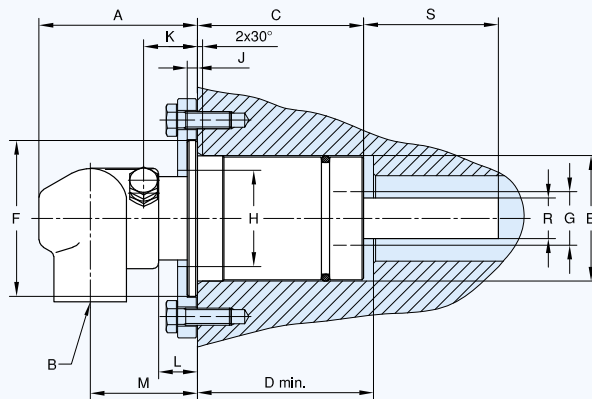

DN	Type	B	Ordering No.	A	C	D	E ∅	F ∅	G ∅	H ∅	J	K	L	M	N	O	P	Q	R ∅	S	kg
15	Monoflow	G 1/2	2412-002-100	50	42	43	40,08 40,33	52,1	12,7	40	5	22	15	36	41	35	-	-	-	-	0,8
20		G 3/4	2420-001-139	59	59	60	46,10 46,35	59	17,5	47	4,7	26,5	19,5	42	48	37	-	-	-	-	1,2
25		G 1	2425-001-172	74	78	83	46,10 46,35	73	25	35	4,7	25,5	18,5	53,5	46	36,5	-	-	-	-	1,3
20	Duoflow	G 3/4	2420-001-141-180	75	59	60	46,10 46,35	59	17,5	47	4,7	26	19	51	39	37	51	85	12,941 12,984	49	1,6
25		G 3/4	2425-001-177-180	75	78	83	58,50 58,75	73	25	35	4,7	25,5	18,5	50,5	39	36,5	51	85	18,948 19,000	63	2,4
40		G 1	2440-001-306-254	98	87	94	71,00 71,25	86	38	51	4,7	26	19	68	43	49,5	64	105	28,45 28,70	48,5	4

Relubrication Guide for DEUBLIN Rotating Unions

All **DEUBLIN** Rotating Unions are factory lubricated and tested, ready for installation. Unions not equipped with grease fittings are lubricated for the life of the union and require no further maintenance. Rotating unions, which are equipped with grease fittings, may require periodic lubrication to replace the grease which has dissipated. Overgreasing can be as damaging to the union as undergreasing, particularly in high-speed applications. Relubrication frequency and amounts of grease vary greatly depending on union size, operating temperature, rotation speed, moisture, etc. The following charts and table provide approximate lubrication frequency and amounts of grease for light and moderate service conditions.

When relubricating **DEUBLIN** Rotating Unions, use CHEVRON SRI GREASE NLGI 2. Only low-pressure grease equipment should be used to prevent damage to the bearings and seals. This is a general guide that should be used judiciously. The user must make adjustments as experience dictates. For more specific information, contact your local lubricant supplier.

Relubrication			
Model	Amount of Grease (g)	Model	Amount of Grease (g)
55	3,5	655	18
155	5,5	755	42
255	10	6200	18
355	10	6250	42
525	12	6300	68
555	18	6400	90

For further information please request our separate Lubrication Guide.

Relubrication Interval

Light Service

Temperatures up to 75 °C
little, if any, vibration or moisture (humidity)

Moderate Service

Temperatures 75 °C - 120 °C
some vibration and moisture present

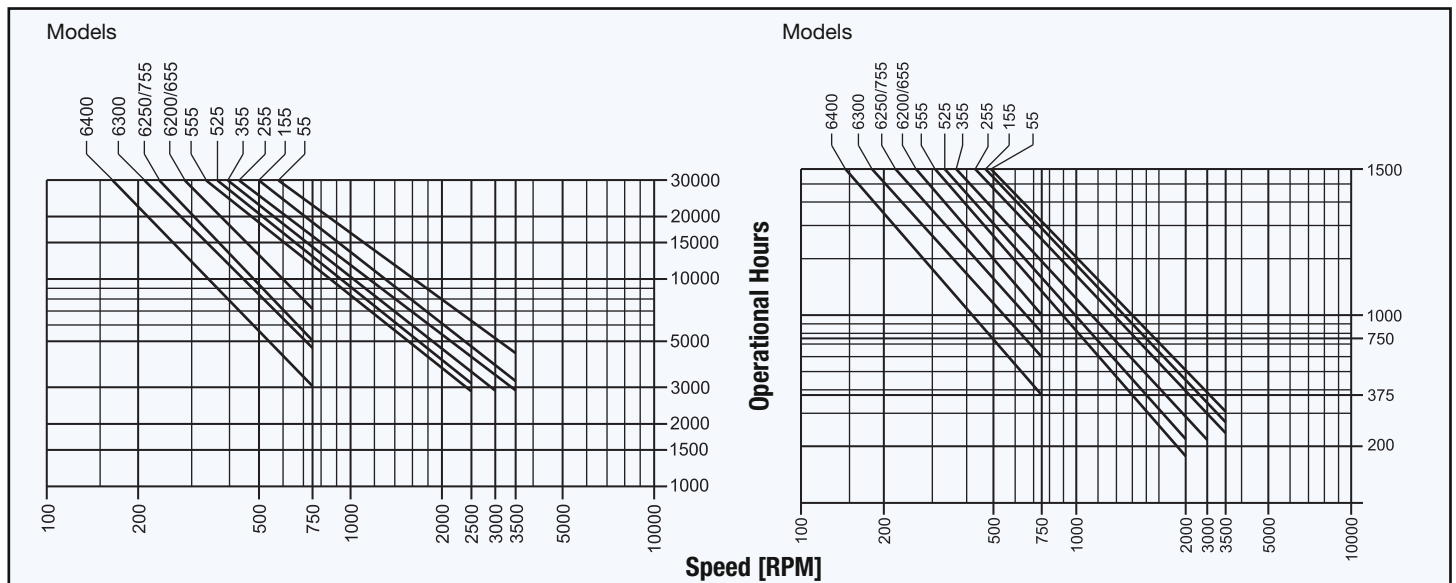

Important Information

A *DEUBLIN* Union is a precision-made piece of equipment and must be handled accordingly. Sealing between the rotating device - rotor - and the static device - stator - is mainly accomplished via floating seals. Improper use could result in premature leakage or failure.

Although *DEUBLIN* Unions are of the highest quality and precision they are, by their very nature, a "wear and tear" product. It's important that they should be inspected periodically. Moreover, when seals wear out, the rotating union must be replaced or repaired to avoid subsequent leakage. Once a union begins to leak, it is paramount that the union be repaired immediately. Never work with leaking unions!

DEUBLIN Unions must never be used for applications other than those specified in the catalogue. It is strictly prohibited to use *DEUBLIN* Unions with hydrocarbons or other flammable media as leakage may result in a fire or explosion. The use of our product on exotic or corrosive media is strictly prohibited without our prior approval. For applications other than those stated in the catalogue, the *DEUBLIN* Engineering Department should be contacted for proper instructions. These instructions are provided by *DEUBLIN* as general guidelines and do not contain exhaustive information about the installation, use or maintenance of unions.

Operating instructions and installation manuals are available in the German and English languages for the greater part of *DEUBLIN* products. Buyers and users of *DEUBLIN* Unions should be certain that they have reviewed all of *DEUBLIN*'s product information. The operating and installation instructions must be strictly adhered to when installing *DEUBLIN* unions.

Factory Testing

All *DEUBLIN* Unions are factory-tested under pressure prior to shipment. This thorough check ensures that each single *DEUBLIN* Union is completely operational when you receive it and can - in most cases - be installed with no further consideration.

Warranty

The buyer's warranty rights assume that the product shipped be inspected upon receipt and all defects reported to *DEUBLIN* in writing immediately or for no longer than a period of 2 weeks. Hidden defects must be reported to *DEUBLIN* in writing immediately upon detection. The warranty is void when the *DEUBLIN* Rotating Union is tampered with or misused in any way. Otherwise, our General Terms of Sale and Delivery are valid. It cannot be emphasised enough that all dynamic seal components are wear parts.

DEUBLIN will not be held liable for damage resulting from improper use, incorrect warehousing, incorrect transport, faulty assembly, faulty operation, insufficient maintenance, incorrect handling, improper installation by the customer, the use of inappropriate accessories or spare parts and natural abrasion. Please request our General Terms of Sale and Delivery.

Lubrication and Maintenance

Depending on the *DEUBLIN* product series and the operating parameters all *DEUBLIN* Unions are lubricated for life or have to be relubricated or serviced according to specially defined intervals. Please follow the respective operating instructions or the general "Relubrication Guide" for *DEUBLIN* Rotating Unions.

Filtering

The service life of the seal is largely determined by filter quality and thus of vital importance for the perfect operation of the rotating union. We recommend a filtering of min. 60 µm. It goes without saying that all installation and operating instructions must be carefully reviewed and strictly adhered to.

Repair Service and Maintenance of *DEUBLIN* Unions by *DEUBLIN*

Use only *DEUBLIN* spare parts for repair of the *DEUBLIN* Rotating Unions. Prior to repair contact *DEUBLIN* or any authorised *DEUBLIN* representative. You can find a local *DEUBLIN* representative at the following internet site: www.deublin.com.

Most unions can be reconditioned in the field by use of *DEUBLIN* Repair or Rebuilding Kits (see page 5). Generally, we recommend having the *DEUBLIN* Rotating Unions repaired by *DEUBLIN*. Repair Service is available at all *DEUBLIN* factories. Factory rebuilt unions carry a "New-Union-Warranty".

Tension-free Installation

When installing rotating unions, special attention has to be paid to a flexible and tension-free hose connection. For further suggestions please refer to our installation instructions.

NPT → G (BSP) Stainless Steel Adapters

Due to worldwide interchangeability most *DEUBLIN* Unions are equipped with NPT hose connections. Make use of our NPT/G (BSP) adapters if you wish to fit hoses with G (BSP) threads.

Type A

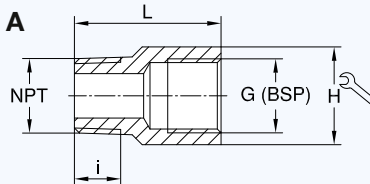

Type B

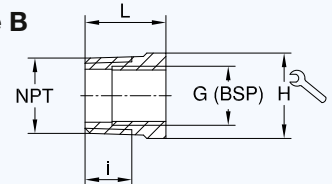

Ordering No.	NPT	G (BSP)	L	i	H	Type	Ordering No.	NPT	G (BSP)	L	i	H	Type
6301-012	1/8	1/4	28	6,7	17	A	6301-065	1	3/4	31	17,3	36	B
6301-022	1/4	1/4	31	10,2	17	A	6301-066	1	1	48	17,3	41	A
6301-032	3/8	1/4	18	10,4	19	B	6301-075	1 1/4	3/4	30	18	46	B
6301-033	3/8	3/8	33	10,4	22	A	6301-077	1 1/4	1 1/4	51	18	50	A
6301-042	1/2	1/4	24	13,6	22	B	6301-085	1 1/2	3/4	34	18,4	50	B
6301-043	1/2	3/8	28	13,6	22	B	6301-088	1 1/2	1 1/2	53	18,4	55	A
6301-044	1/2	1/2	37	13,6	27	A	6301-097	2	1 1/4	50	19,2	65	B
6301-054	3/4	1/2	26	13,9	27	B	6301-099	2	2	70	19,2	65	A
6301-055	3/4	3/4	41	13,9	32	A	6301-108	2 1/2	1 1/2	80	22,5	75	B
6301-064	1	1/2	31	17,3	36	B	6301-1010	2 1/2	2 1/2	80	22,5	90	A

	Units		Units of Measure in Common Use:						Conversion Factors
	SI	USA	D	E	F	I	NL	S	
Speed	1/s	RPM	min ⁻¹	r.p.m.	t/min	g/min	min ⁻¹	min ⁻¹	1 RPM = min ⁻¹ = 1/60 S
Temperature	K (Kelvin)	°F	°C	°C	°C	°C	°C	°C	(°F-32) 5/9 ± °C ± K-273
Pressure	Pa	PSI	bar	bar	bar	bar	bar	bar	14.5 PSI ± 1 bar ± 1.02 kg/cm ² ± 100 kPa
Vacuum	Pa	"Hg	kPa	cmHg	cmHg	kPa	bara	kPa	28" Hg (Vac) ± 2" Hg ± 5.08 cmHg ± 6.75 kPa ≈ 0.07 bara
Weight	kg	# (lbs)	kg	kg	kg	kg	kg	kg	2.2 # ± 1.0 kg

Instructions of Hose Installation and Assembly of *DEUBLIN* Rotating Unions



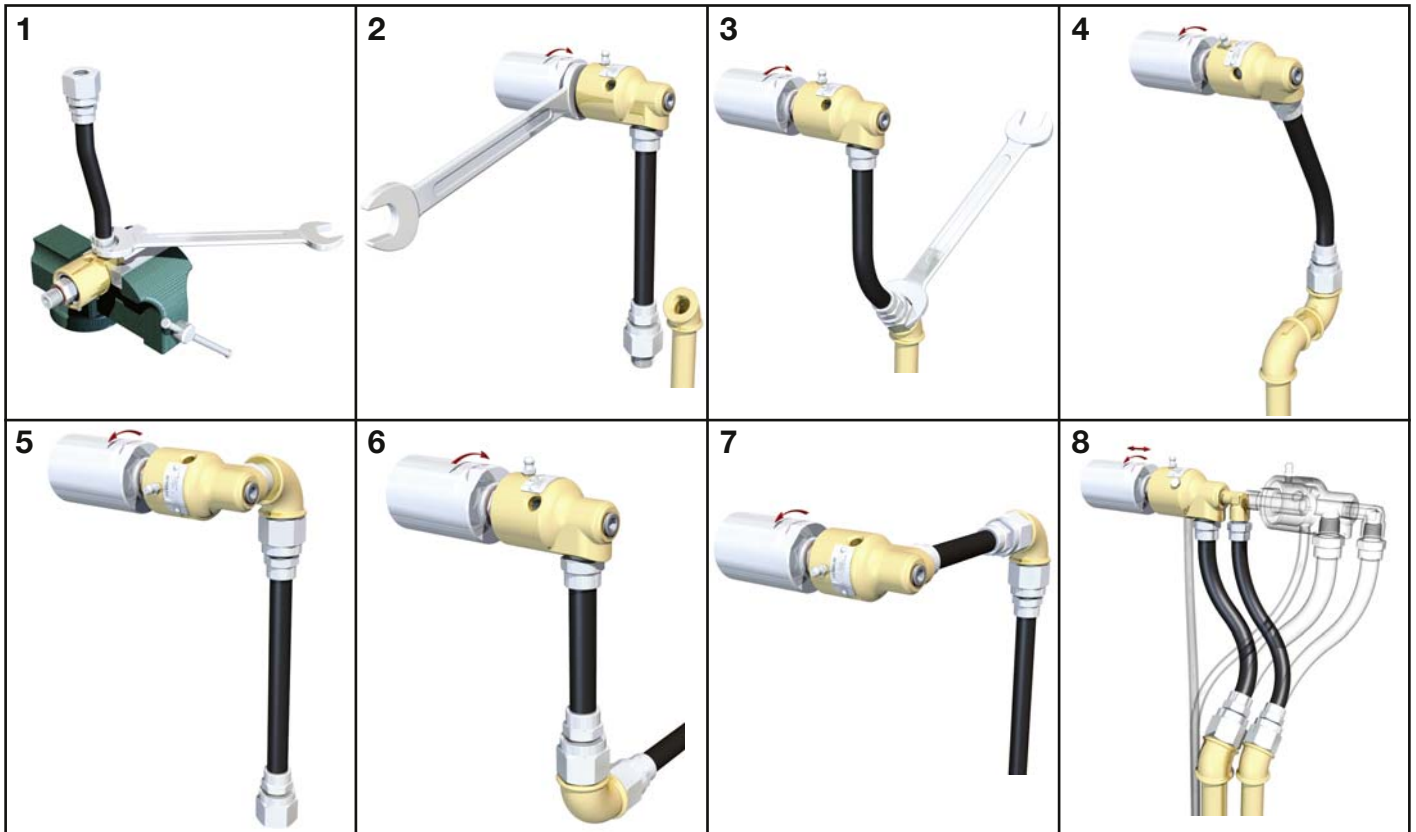

Example Rotating Union 55/57 Series

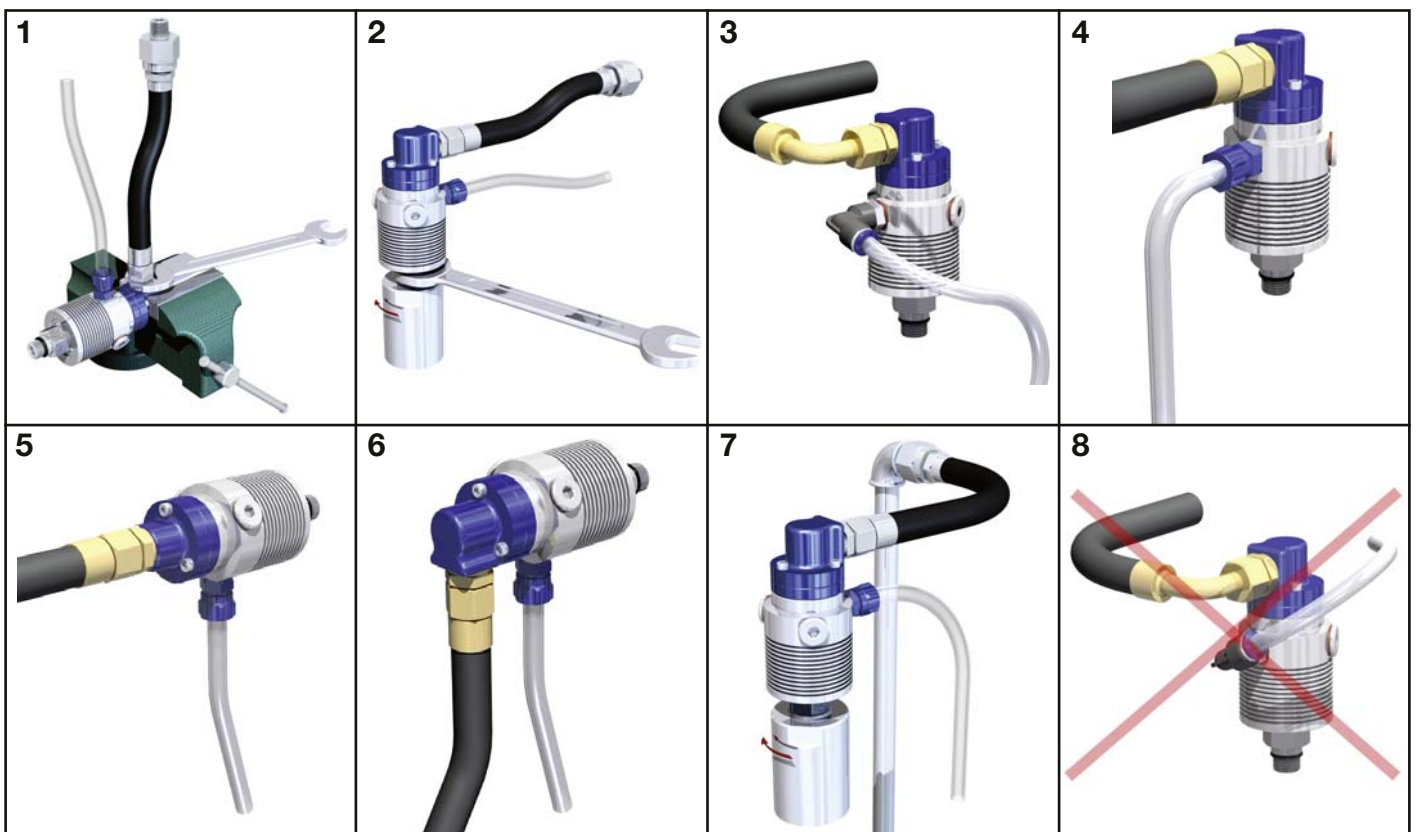

Example Rotating Union 1109 Series

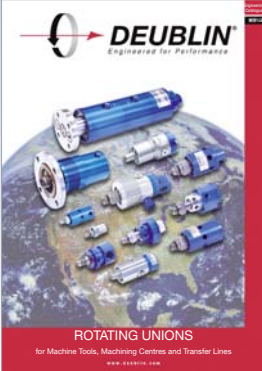

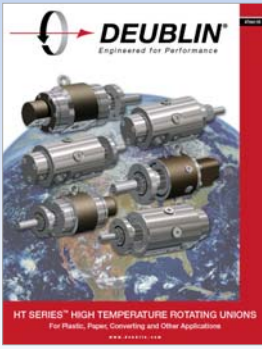
Additional Catalogues with Customised Applications for Special Industries

<h2 style="margin: 0;">Machine Tool</h2>		<h2 style="margin: 0;">High Pressure Hydraulic</h2>	
 <p style="font-size: small; margin-top: 5px;"> ROTATING UNIONS for Machine Tools, Machining Centres and Transfer Lines www.deublin.com </p>	<p>Rotating unions for air, hydraulic, coolant, cutting oil and oil/air mist lubrication service in machine tools, machining centres, transfer lines and special machines</p>	 <p style="font-size: small; margin-top: 5px;"> ROTATING UNIONS for High Pressure Hydraulic Service www.deublin.com </p>	<p>Monoflow and duoflow rotating unions in wind and water power plants as well as in coil winding plants; optional with central passage for slip ring</p>
<h2 style="margin: 0;">Continuous Casting</h2>		<h2 style="margin: 0;">Hot Media</h2>	
 <p style="font-size: small; margin-top: 5px;"> ROTATING UNIONS For Continuous Casting Machines www.deublin.com </p>	<p>Rotating unions for water service to cool the caster rolls in continuous casting plants and rolling mills; bearingless unions available</p>	 <p style="font-size: small; margin-top: 5px;"> HT SERIES™ HIGH TEMPERATURE ROTATING UNIONS For Plastic, Paper Conveying and Other Applications www.deublin.com </p>	<p>Rotating unions for water and hot oil services in various applications in the plastics and other industries</p>
<h2 style="margin: 0;">Paper</h2>		<h2 style="margin: 0;">Special Solutions</h2>	
 <p style="font-size: small; margin-top: 5px;"> ROTATING JOINTS AND SIPHON SYSTEMS For the Paper Industry www.deublin.com </p>	<p>Rotating unions for steam and hot oil service for paper manufacturing; siphon systems and turbulence bars for the paper industry</p>	<p>Special rotating unions, customised versions and modular designs for various media and applications</p>	



Since its establishment in 1945, **DEUBLIN** has consistently adhered to a policy of producing the best product of its kind in the market. The result of this policy has been constant growth through the years. For this progress we are grateful to our many loyal customers.

We cordially invite you to visit our modern manufacturing facilities in Waukegan, Illinois; Hofheim-Wallau, Germany; Monteveglio, Italy and Dalian, China.

Sincerely,

Donald L. Deubler
Chairman of the Board



Our International Headquarters in Waukegan, Illinois, U.S.A.



Hofheim-Wallau, Germany



Bologna, Italy

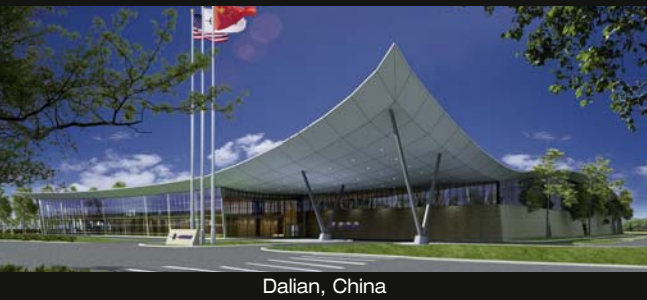

Dalian, China

Catalogues are available in the following languages:

Dutch	Italian	Russian
English	Japanese	Swedish
Finnish	Korean	Spanish
French	Polish	Turkish
German	Portuguese	



**SERVICE AND STOCK ARE
AVAILABLE THROUGHOUT
THE WORLD**

www.deublin.com

AMERICA

DEUBLIN Company

2050 Norman Drive, West
Waukegan, IL 60085-6747 U.S.A.
Phone: 847 689-8600
Fax: 847 689-8690
e-mail: customerservice@deublin.com

CANADIAN OFFICE

9454 Route Trans-Canadienne
St-Laurent, Quebec H4S 1R7 Canada
Phone: 514 745-4100
Fax: 514 745-8612
e-mail: customerservice@deublin.com

DEUBLIN de Mexico S. De R.L. de C.V.

Norte 79-A No. 77, Col. Claveria
02080 Mexico, D.F.
Phone: (52) 55-5342-0362
Fax: (52) 55-5342-0157
e-mail: deublin@prodigy.net.mx

DEUBLIN Brasil

Juntas Rotativas de Precisão Ltda.
Rua Santo Antonio, 1426 - Vila Galvão
Guarulhos, São Paulo Brazil 07071-000
Phone: (55) 11-2455-3245
Fax: (55) 11-2455-2358
e-mail: deublinbrasil@deublinbrasil.com.br

ASIA

DEUBLIN (Dalian)

Precision Rotating Unions Co. Ltd
No. 2, 6th DD Street, DD Port Dalian
Liaoning Province, 116620, P.R. China
Phone: (86) 411-87549678
Fax: (86) 411-87549679
e-mail: info@deublin.cn

DEUBLIN Asia Pacific Pte Ltd

51 Goldhill Plaza, #11-11/12
Singapore 308900
Phone: (65) 6259-9225
Fax: (65) 6259-9723
email: deublin@singnet.com.sg

DEUBLIN Asia Pacific Pte Ltd

Shanghai Representative Sales Office
China Merchants Plaza 12th Floor,
Suite (East) 1208
333 Chengdubai Road
Shanghai, 200041 China
Phone: (86) 21-52980791
Fax: (86) 21-52980790
e-mail: service@deublin.cn

DEUBLIN Japan Limited

2-13-1, Minamihanayashiki
Kawanishi City 666-0026, Japan
Phone: (81) 72-757-0099
Fax: (81) 72-757-0120
e-mail: customerservice@deublin-japan.co.jp

DEUBLIN Japan Limited

2-4-10-3F Ryogoku
Sumida-Ku, Tokyo 130-0026, Japan
Phone: (81) 35-625-0777
Fax: (81) 35-625-0888
e-mail: customerservice@deublin-japan.co.jp

DEUBLIN Korea Co., Ltd

104-11, Ssang-Ryung-Dong
Kwang-Ju-Si, Kyung-Gi-Do, Korea
Phone: (82) 31-763-3311
Fax: (82) 31-763-3309
e-mail: customerservice@deublin.co.kr

EUROPE

DEUBLIN GmbH

Nassaustraße 10
65719 Hofheim, Germany
Phone: (49) 6122-8002-0
Fax: (49) 6122-15888
e-mail: info@deublin.de

DEUBLIN Italiana S.r.l.

Via Guido Rossa 9
40050 Monteveglio (BO), Italy
Phone: (39) 051-835611
Fax: (39) 051-832091
e-mail: info@deublin.it

Via Giovanni Falcone 36
20010 Bareggio (MI), Italy
Phone: (39) 02-90312711
Fax: (39) 02-90278189
e-mail: info@deublin.it

DEUBLIN Ltd.

6 Sopwith Park, Royce Close, West Portway
Andover SP10 3TS, UK
Phone: (44) 1264-333355
Fax: (44) 1264-333304
e-mail: deublin@deublin.co.uk

DEUBLIN Sarl

61 bis, Avenue de l'Europe
Z.A.C de la Malnoue
77184 Emerainville, France
Phone: (33) 1-64616161
Fax: (33) 1-64616364
e-mail: service.client@deublin.fr

DEUBLIN Ibérica, S.L.

Avda. Bogatell 23
08005 Barcelona, Spain
Phone: (34) 93-2211223
Fax: (34) 93-2212093
e-mail: serviciocliente@deublin.es

DEUBLIN Polska Sp. z o.o

ul. Kamińskiego 201-219
51-126 Wrocław, Poland
Phone: (48) 71-3528152
Fax: (48) 71-3207306
e-mail: info@deublin.pl

DEUBLIN Austria GmbH

Trazerberggasse 1/2
1130 Wien, Austria
Phone: (43) 1-8768450
Fax: (43) 1-876845030
e-mail: info@deublin.at

DEUBLIN Finland Oy

Kivääritehtaankatu 8
40100 Jyväskylä, Finland
Phone: (358) 207 290 210
Fax: (358) 207 290 219
e-mail: info@deublin.fi

DEUBLIN Italiana S.r.l. - Swedish Filial

Cylindervägen 18, Box 1113
13 126 Nacka Strand, Sweden
Phone: (46) 8 716 2033
Fax: (46) 8 601 3033
e-mail: info@deublin.se