

ez-Wheel **ezW160I** provides electric assistance to :

- Industrial hand trucks
- Roll carts
- Mobile equipment on concrete surface
- ...

Immediate fitting

The self-propelled ez-Wheel can be fitted immediately on any vehicle chassis or mobile equipment. The wheel is self-powered by the built-in battery and driven by wired or wireless communication.

Reduced space requirement

The series 160 integrates motor and batteries in an extremely compact format. The wheel is designed with reduced height to fit any low chassis. The robust hub fairing protects all components from knocks and splashing.

Reduced pushing effort

The peak torque of the electric motor develops a pushing force of 20 daN. It provides a reduced effort and a safe action of any rolling material equipped with the wheel.

Extended compatibility

The series 160 are available with wire connections or with external batteries to allow junctions to other electrical peripherals. The motor can also be powered by an external battery, if already available on the material.

Environmentally responsible

The approach to ez-Wheel product design is to minimize environmental impact. Collection and recycling are organized for products reaching the end of their lifecycle. Contact your dealer for more information.



Main specifications

Diameter	158 mm
Type of tyre	70 sh. A solid tyre Flat profile
Speed	0 to 5 km/h
Nominal Power	70 W (S1 at 4 km/h)
Battery capacity	70 Wh (1 battery) 140 Wh (2 batteries)
Torque peak	17 Nm 20 daN of pushing force
Options	0/1/2 batteries - Brake - Encoder

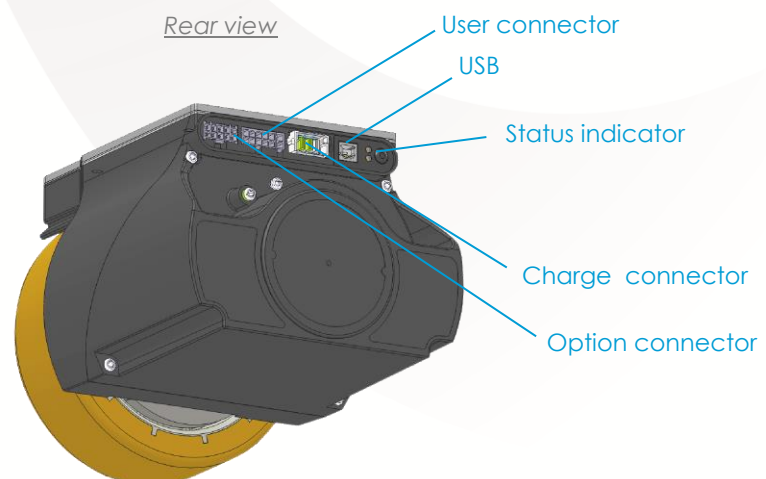

High-Tech built-in solution

All the components necessary for traction are built into the wheel: the electric motor, high energy, very long life batteries, a power controller ensuring optimum motor control and battery management and a wired or wireless interface.

Motor specification

Technology	DC PM
Maximum speed	160 rpm
Nominal power	70 W (S1 at 130 rpm)
Peak torque	17 Nm

Battery

Electrochemistry	Ni-MH
Energy	0 / 70 / 140 Wh
Lifespan	2 years
Recharge	Charger
Recharging time	1 hour (for 90% with 1 batt.)

Interface

Wired	Analogic / Serial
-------	-------------------

Multi-purpose

The wheel can be used inside or outside, over a wide range of temperatures. The components – including the battery – do not need any inspection or maintenance over the product's whole lifespan.

The casing enables the wheel to bear a load of up to 100 kg. The robust assembly can withstand the stresses of knocks and severe vibration.

Conditions of use

Temperature	-10 to +40°C
IP index	IP54

Weight

Total weight wheel	6 kg (with 1 battery)
Maximum load	100 kg

Warranty

ez-Wheel products are guaranteed 1 year from the date of purchase. Consult the general conditions of sale for more information.

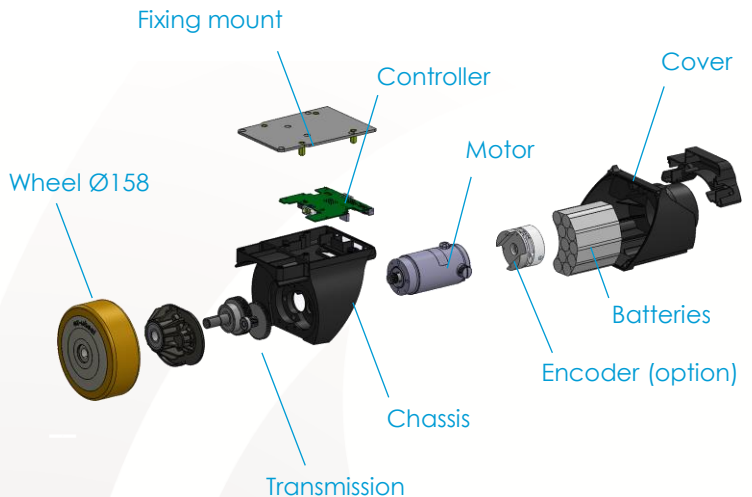

Standard

The standardized dimensions and mechanical interface make it simple and quick to fit the product. The integrated mount is fixed to the chassis with 4 bolts, just like a simple caster.

The wheel hub is fitted with a solid, 15 mm thick polyurethane tyre 70 shore A for drive wheels. The solid tyre does not require any maintenance or servicing and does not need to be replaced.

Functional dimensions

Wheel diameter	158 mm
Thickness of solid tyre	15 mm
Width of solid tyre	60 mm
Total height	175 mm
Total width	186 mm
Total length	231,30 mm
Ground clearance	31 mm

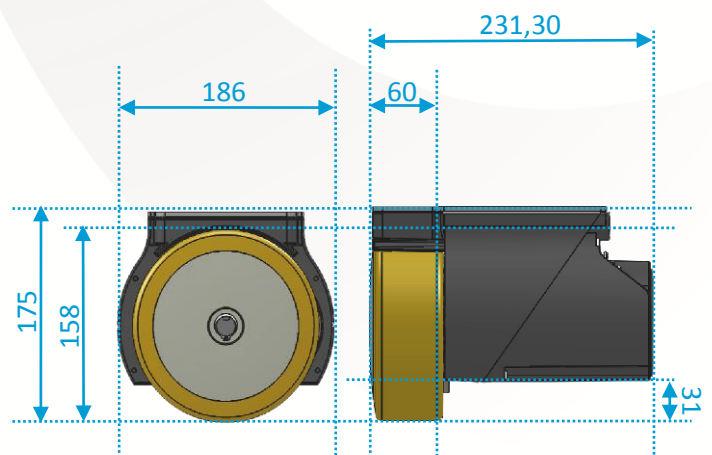

2D and 3D drawings available at www.ez-wheel.com