

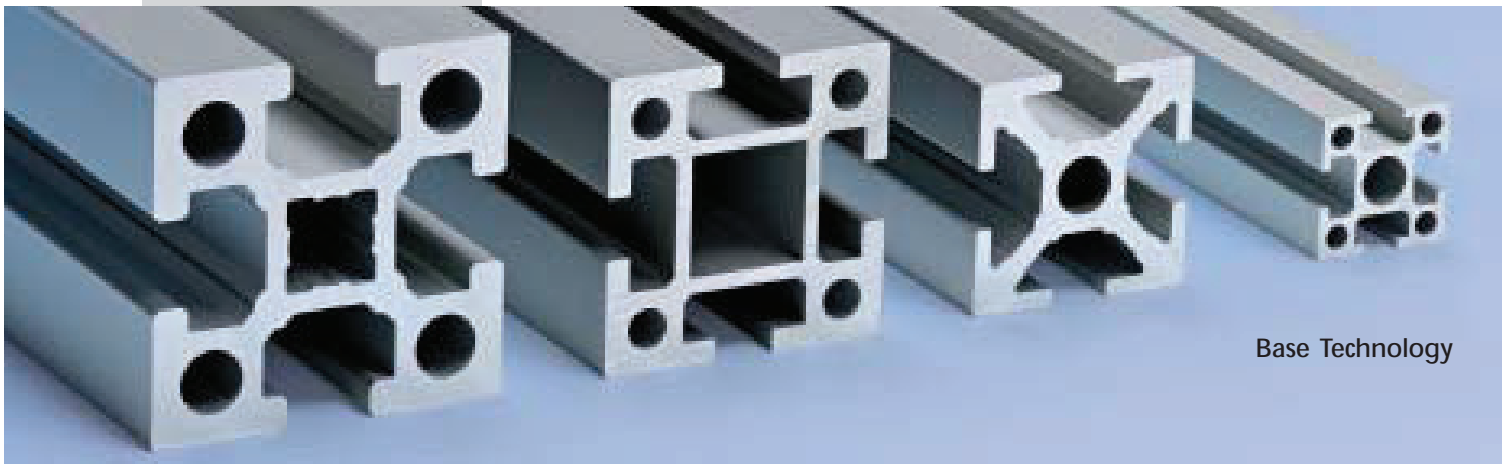

mk Profile Technology

One construction kit – many options



Base Technology

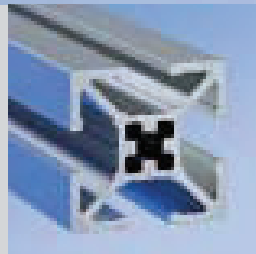

Profile Technology



Conveyor Technology

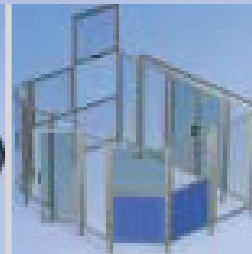

Factory Equipment













Linear Motion

"mk creating flexibility through modularity"

The mk system is based on high-quality aluminum profiles. Over 250 different profiles, extensive connectors and a large range of accessories form the basis of the four mk business segments: mk profile technology, mk conveyor technology, mk linear technology (linear motion) and mk factory equipment. Select the mechanical components and modules from our extensive system construction kit to create all the basic functions of your automation systems. Make decisions based on your production capacity, for example; on when and where you purchase the system components; as individual units, as an assembly kit or as a fully functional module. Your benefits:

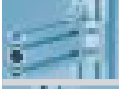
The mk system can radically simplify complex machinery design and construction and makes it more effective because the individual mk system components can easily be combined with each other. In this way, you can achieve optimum plant and system configurations. The system is flexible and the materials used are of the highest quality. This enables expansion, or any equipment changes, to be easily implemented. Last, but not least, system construction using standard components enables you to considerably simplify your entire project planning process and to reduce project costs and risks by purchasing specific functions at fixed prices!

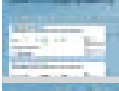
Table of contents

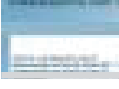
| | | |
|---|--|-----|
|  | Quick-Reference | 4 |
|  | Introducing mk | 10 |
|  | Our Business Fields | 14 |
|  | How to use the Catalog | 22 |
|  | Information about Profile Technology | 24 |
|  | Using the mk profile technology system | 26 |
|  | mk Structural Profiles | 28 |
|  | mk Assembly Components | 82 |
|  | mk Accessory Components | 144 |
|  | mk Assemblies | 230 |
|  | Technical Data | 238 |
|  | Design examples | 260 |
|  | Network and Support | 278 |
|  | Index | 284 |

Quick-Reference Structural Profiles

Series 25

Series 40

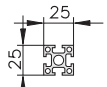

mk 2025.01
25.01.*
Page 31

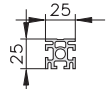

mk 2025.31
25.31.*
Page 32

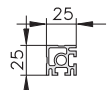

mk 2025.35
25.35.*
Page 32

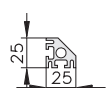

mk 2025.38
25.38.*
Page 32



mk 2025.37
25.37.*
Page 33



mk 2025.16
25.16.*
Page 33

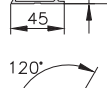

mk 2025.17
25.17.*
Page 33

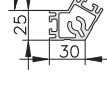

mk 2025.18
25.18.*
Page 33

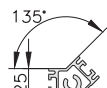

mk 2025.19
25.19.*
Page 33

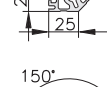

mk 2025.02
25.02.*
Page 31

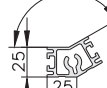

mk 2025.32
25.32.*
Page 33

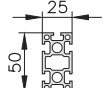

mk 2025.36
25.36.*
Page 33

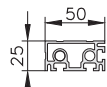

mk 2025.39
25.39.*
Page 33

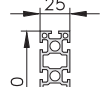

mk 2025.03
25.03.*
Page 31

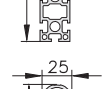

mk 2025.22
25.22.*
Page 34

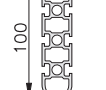

mk 2025.04
25.04.*
Page 31

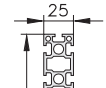

mk 2025.05
25.05.*
Page 31

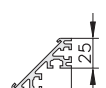

mk 2025.25
25.25.*
Page 33

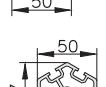

mk 2025.20
25.20.*
Page 34

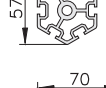

mk 2025.21
25.21.*
Page 34

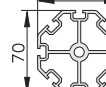

mk 2025.41
25.41.*
Page 35

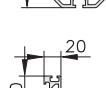

mk 2025.42
25.42.*
Page 35

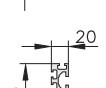

mk 2025.43
25.43.*
Page 35

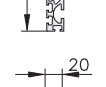
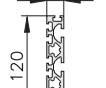
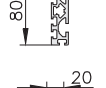

mk 2025.44
25.44.*
Page 35

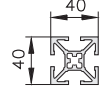

mk 2040.31
54.31.*
Page 37

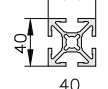

mk 2040.40
54.40.*
Page 37

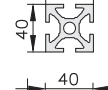

mk 2040.01
54.01.*
Page 37

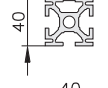

mk 2040.21
54.21.*
Page 40

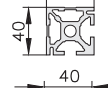

mk 2040.11
54.11.*
Page 40

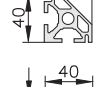

mk 2040.14
54.14.*
Page 40

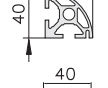

mk 2040.15
54.15.*
Page 40

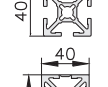

mk 2040.92
54.92.*
Page 42

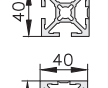

mk 2040.93
54.93.*
Page 42

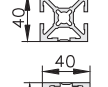

mk 2040.94
54.94.*
Page 43

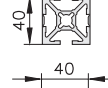

mk 2040.95
54.95.*
Page 43

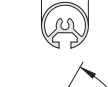

mk 2040.16
54.16.*
Page 42



mk 2040.17
54.17.*
Page 41

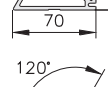

mk 2040.18
54.18.*
Page 41

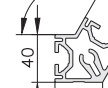

mk 2040.19
54.19.*
Page 41

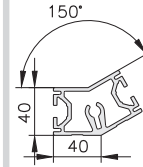

mk 2040.20
54.20.*
Page 41

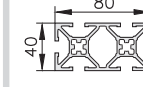

mk 2040.52
54.52.*
Page 37

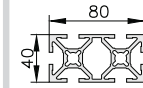

mk 2040.41
54.41.*
Page 38

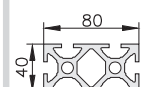

mk 2040.02
54.02.*
Page 38

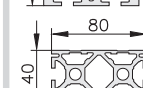

mk 2040.22
54.22.*
Page 41

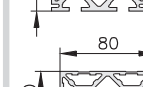

mk 2040.12
54.12.*
Page 41

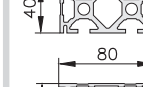

mk 2040.24
54.24.*
Page 41

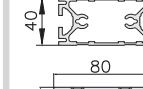

mk 2040.100
54.100.*
Page 43

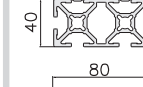

mk 2040.101
54.101.*
Page 43

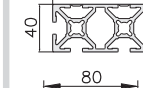

mk 2040.23
54.23.*
Page 48

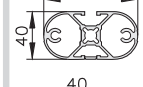

mk 2040.05
54.05.*
Page 38

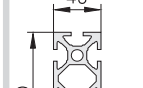



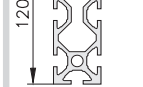





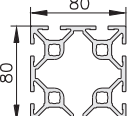

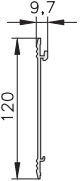
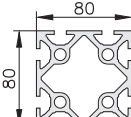

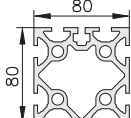

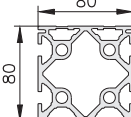
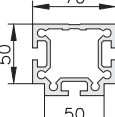

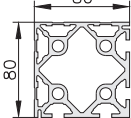
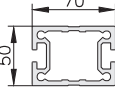

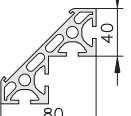
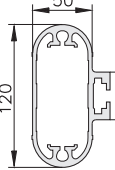
mk 2040.34
54.34.*
Page 48

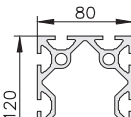

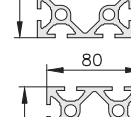
mk 2040.06
54.06.*
Page 38

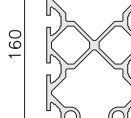
Series 40 

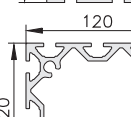
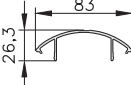
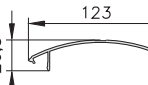
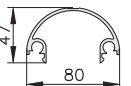
| | | | | | |
|---|---------------------------------------|---|---------------------------------------|---|---------------------------------------|
|  | mk 2040.45 54.45.* Page 38 |  | mk 2040.37 54.37.* Page 47 |  | mk 2040.85 54.85.* Page 53 |
|  | mk 2040.03 54.03.* Page 38 |  | mk 2040.38 54.38.* Page 47 |  | mk 2025.41 25.41.* Page 50 |
|  | mk 2040.73 54.73.* Page 38 |  | mk 2040.39 54.39.* Page 47 |  | mk 2025.42 25.42.* Page 50 |
|  | mk 2040.46 54.46.* Page 41 |  | mk 2040.74 54.74.* Page 47 |  | mk 2025.43 25.43.* Page 50 |
|  | mk 2040.13 54.13.* Page 41 |  | mk 2040.75 54.75.* Page 47 |  | mk 2025.44 25.44.* Page 50 |
|  | mk 2040.04 54.04.* Page 41 |  | mk 2040.30 54.30.* Page 48 |  | mk 2040.80 54.80.* Page 51 |
|  | mk 2040.07 54.07.* Page 39 |  | mk 2244 52.44.* Page 49 |  | mk 2040.86 54.86.* Page 51 |
|  | mk 2040.08 54.08.* Page 39 |  | mk 2245 52.45.* Page 49 | | |
|  | mk 2040.10 54.10.* Page 39 |  | mk 2040.43 54.43.* Page 52 | | |
|  | mk 2040.09 54.09.* Page 39 |  | mk 2040.42 54.42.* Page 52 | | |
| | |  | mk 2040.44 54.44.* Page 52 | | |
| | |  | mk 2040.32 54.32.* Page 52 | | |

Quick-Reference Structural Profiles

Serie 50

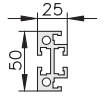

mk 2001
51.01.*
Page 55

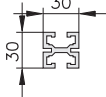

mk 2030
51.30.*
Page 55

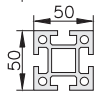

mk 2000
51.00.*
Page 55

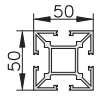

mk 2002
51.02.*
Page 55

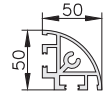

mk 2003
51.03.*
Page 56

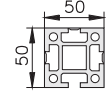

mk 2017
51.17.*
Page 57

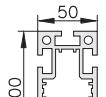

mk 2004
51.04.*
Page 55

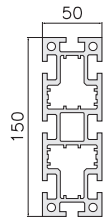

mk 2006
51.06.*
Page 56

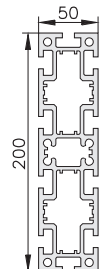

mk 2008
51.08.*
Page 56

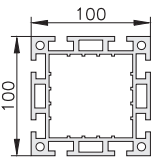

mk 2005
51.05.*
Page 56

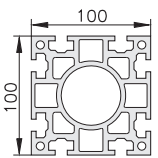

mk 2011
51.11.*
Page 56

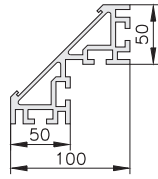

mk 2072
51.72.*
Page 56

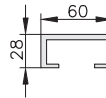

mk 2033
51.33.*
Page 58

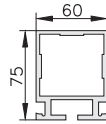

mk 2031
51.31.*
Page 58

Serie 60

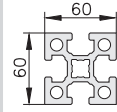

mk 2060.01
60.01.*
Page 61

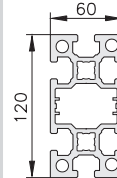

mk 2060.02
60.02.*
Page 61

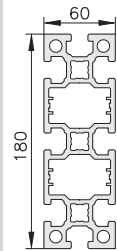

mk 2060.03
60.03.*
Page 61

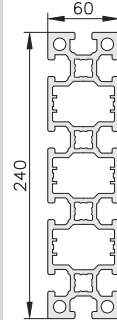

mk 2060.04
60.04.*
Page 62

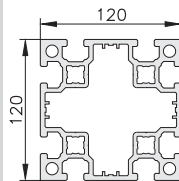

mk 2060.05
60.05.*
Page 62

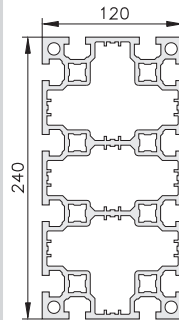

mk 2060.07
60.07.*
Page 62

... for Sliding Windows

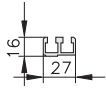

mk 2240
52.40.*
Page 63



mk 2241
52.41.*
Page 63

... for Sheets and Paneling



mk 2206
52.06.*
Page 64



mk 2207
52.07.*
Page 64

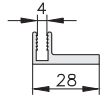

mk 2203
52.03.*
Page 64

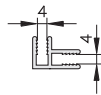

mk 2210
52.10.*
Page 64

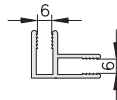

mk 2211
52.11.*
Page 64

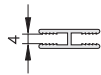

mk 2214
52.14.*
Page 64

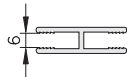

mk 2215
52.15.*
Page 64

... for Door Frames

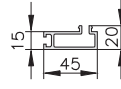

mk 2040.88
54.88.*
Page 65

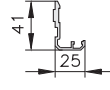

mk 2040.25
54.25.*
Page 65

... for Floors and Steps

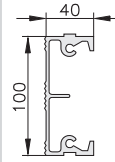

mk 2040.68
54.68.*
Page 66

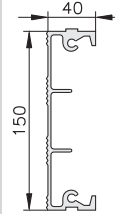

mk 2040.69
54.69.*
Page 66

Foamed Profiles

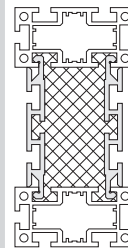

Foamed Profiles
up to Page 68

Profile Services



up to Page 72

Quick-Reference Assembly Components

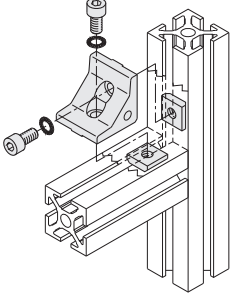
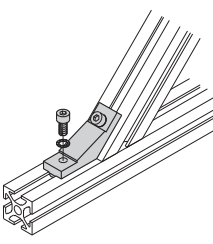
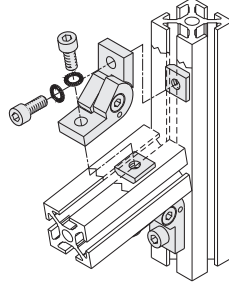
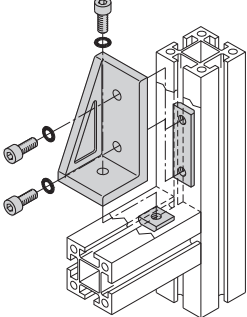
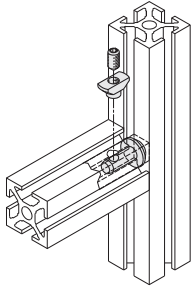
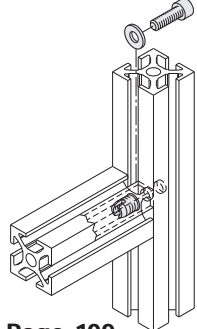
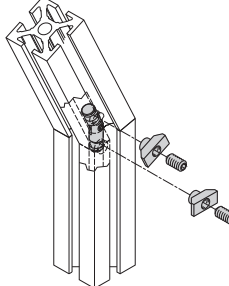
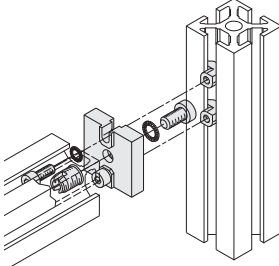
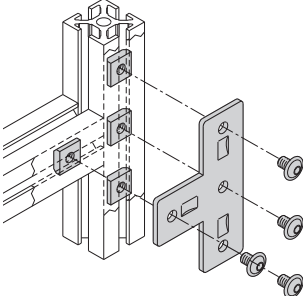
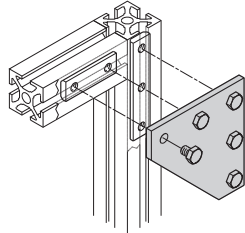
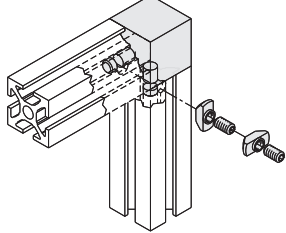
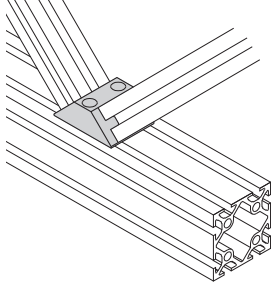
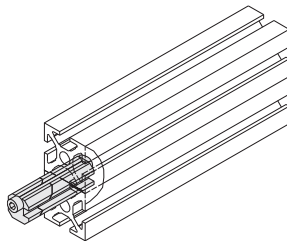
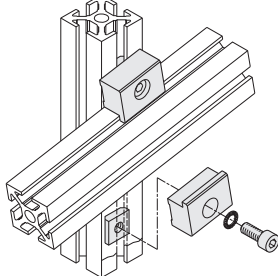
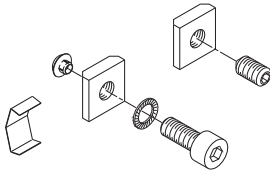
| Angles for 90° | Angles for 30°/45°/60° | Adjustable Angles | Consoles |
|---|---|--|---|
|  <p data-bbox="170 667 300 703"> Page 86</p> |  <p data-bbox="487 667 617 703"> Page 100</p> |  <p data-bbox="812 667 941 703"> Page 102</p> |  <p data-bbox="1136 667 1266 703"> Page 104</p> |
| Internal Fasteners | Internal Fastener Series 40 light | Swivel Tension Plug | Connecting plates for assembly at profile ends |
|  <p data-bbox="170 1102 300 1138"> Page 108</p> |  <p data-bbox="487 1102 617 1138"> Page 109</p> |  <p data-bbox="812 1102 941 1138"> Page 111</p> |  <p data-bbox="1136 1102 1266 1138"> Page 112</p> |
| Plates Light version | Plates Heavy duty version | Corner Blocks | Profile Wedges, Angle Braces |
|  <p data-bbox="170 1537 300 1572"> Page 113</p> |  <p data-bbox="487 1537 617 1572"> Page 116</p> |  <p data-bbox="812 1537 941 1572"> Page 121</p> |  <p data-bbox="1136 1537 1266 1572"> Page 129</p> |
| Parallel Connectors | Clamps | Screws, Nuts and Spring Washers | |
|  <p data-bbox="170 1963 300 1999"> Page 132</p> |  <p data-bbox="487 1963 617 1999"> Page 134</p> |  <p data-bbox="812 1963 941 1999"> Page 136</p> | |

Quick-Reference Accessory Components

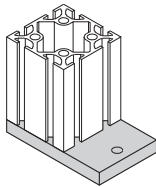
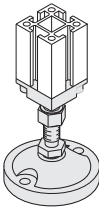
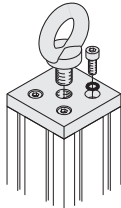
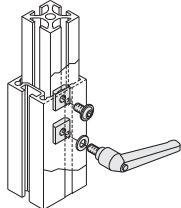
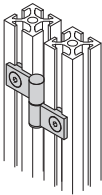
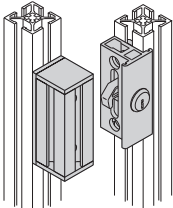
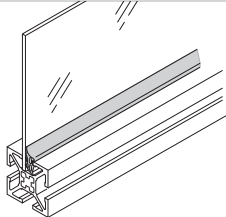
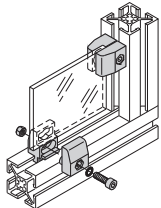
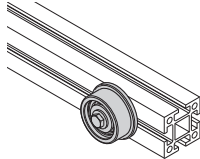
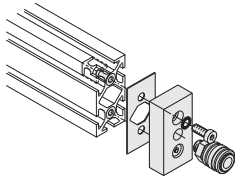
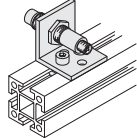
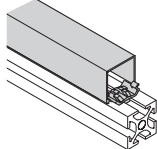
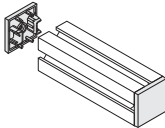
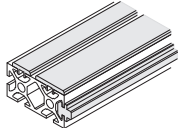
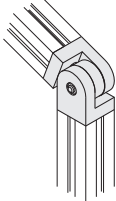
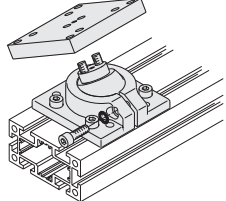
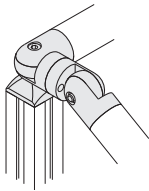
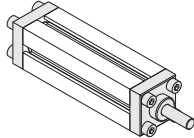
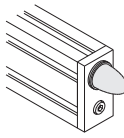
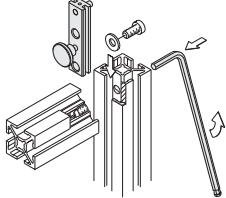
| Floor Mounting Plates | Leveling Pads | Hoists | Operating elements |
|---|---|--|---|
|  |  |  |  |
| Page 148 | Page 158 | Page 168 | Page 169 |
| Door Components, Hinges | Door components, Latches, Locks | Closure and Seal Strips | Paneling and Accessories |
|  |  |  |  |
| Page 172 | Page 177 | Page 182 | Page 184 |
| Rollers | Pneumatic Components | Sensor Brackets | Wireways |
|  |  |  |  |
| Page 192 | Page 195 | Page 198 | Page 199 |
| End Caps | Wear Strips | Swivel Joints | Ball Bases |
|  |  |  |  |
| Page 200 | Page 204 | Page 208 | Page 212 |
| Accessory Components for Guardrails | Glides and Bushings | Bumpers | Tools |
|  |  |  |  |
| Page 218 | Page 220 | Page 222 | Page 224 |

Introducing mk

Your tasks are what
drive us – worldwide



*"Modular products which fulfill the functions
of automation systems at fixed prices"*

As a mechanical engineer, you develop automation systems to help your customers optimize their production processes and to save costs. The mk Technology Group supports you in this task by supplying the technical components and modules which make complex engineering easier and your production process more efficient. Take advantage of the mk system which has been

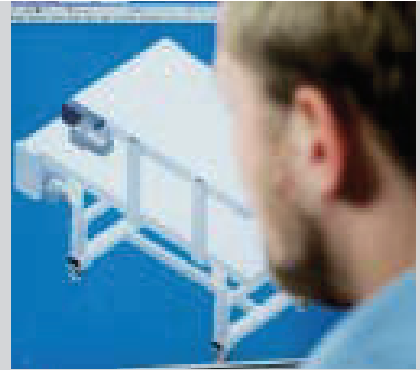

developed over some 40 years for your benefit, and with great enthusiasm for technical solutions and an understanding of market requirements. We are able to supply you with everything you need from a single source based on the uniform construction principle – modular and flexible, and with the highest quality. From simple profile elements for building precise machine frames to

the complex linear and conveyor technology modules through to system elements for your factory equipment. All of the mk business segments are part of a modular system and are therefore compatible with each other. You order the parts you need – we deliver them quickly and reliably, assembled or not, just as you need them. Why not do what countless other satisfied customers

across the world do – construct with mk! It doesn't matter whether you are in the special mechanical engineering sector and are looking for a competent, reliable and flexible partner for your projects, or whether you are involved in standard mechanical engineering and rely on dependable suppliers who provide high-quality sub-components for your systems. We know your market and its requirements.

Introducing mk

The mk modular system – systematically advantageous



The advantages of the mk modular system

- Everything from a single source: Compatible profile, conveyor and linear technologies as well as factory equipment
- Outsourcing of fixed project functions at fixed prices helps integrators to optimize their project costs and risks
- Covers all basic mechanical functions of automation systems (support structure, conveyor technology, handling and safety elements)
- Widest system profile range on the market reduces the need for special design and therefore provides a cost benefit due to standardization
- Simplified system project planning through modular design and compatibility
- Top material quality for high load-bearing capacity and long lifetimes
- Maximum flexibility for system expansions or modifications due to the compatibility and reusability of the individual components and modules
- Utilize your resources optimally due to the freely selectable degree to which our products can be assembled
- Simplification of planning & design thanks to online CAD library and 3D configurator
- Reduced production and assembly times by the use of threaded connectors
- 24-hour ordering available from the mk online shop
- Online order tracking creates transparency

Our range of products and services



One basic technology, four business segments, thousands of products and constant engineering innovation: That is mk.

Profile technology, conveyor technology, linear motion technology

and factory equipment – mk supplies the complete system construction kits for all of the essential basic functions of automation systems – standardized and compatible. And everything is available from a single source.

From the provision of individual components and assemblies to modules right down to complete solutions. Put your trust in the flexible and practical mk system with its countless benefits!

mk – the definition of service



Consultation

Consultation and advice from mk regarding your project allows you to benefit from all our strengths. Sales staff with considerable experience and professional consultant engineers with both analysis and method expertise are able to assist you in designing solutions based on modular products.



Conceptual design & proposal

For the best solution at the best price, we provide the following services:

- Simulation and tests/
engineering services
 - CAD library
 - Design
- Configurator for
perimeter guarding
- Tools for preparing
quotations, price lists
- Contact on site



Production

We develop components and modules for your factory automation. When it comes to setting up your system using mk products, this means you decide whether modules are to be delivered assembled or unassembled – depending how you require them for your own project process.

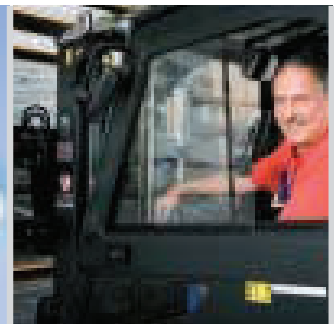

After-sales support

- International, locally based support from locations worldwide
 - Compatibility and modularity of all mk products
 - Maintenance and Service agreements for mk products selectable response times
 - Stability-oriented pricing policy
- Spare parts supply

Our Business Fields –
mk Profile Technology

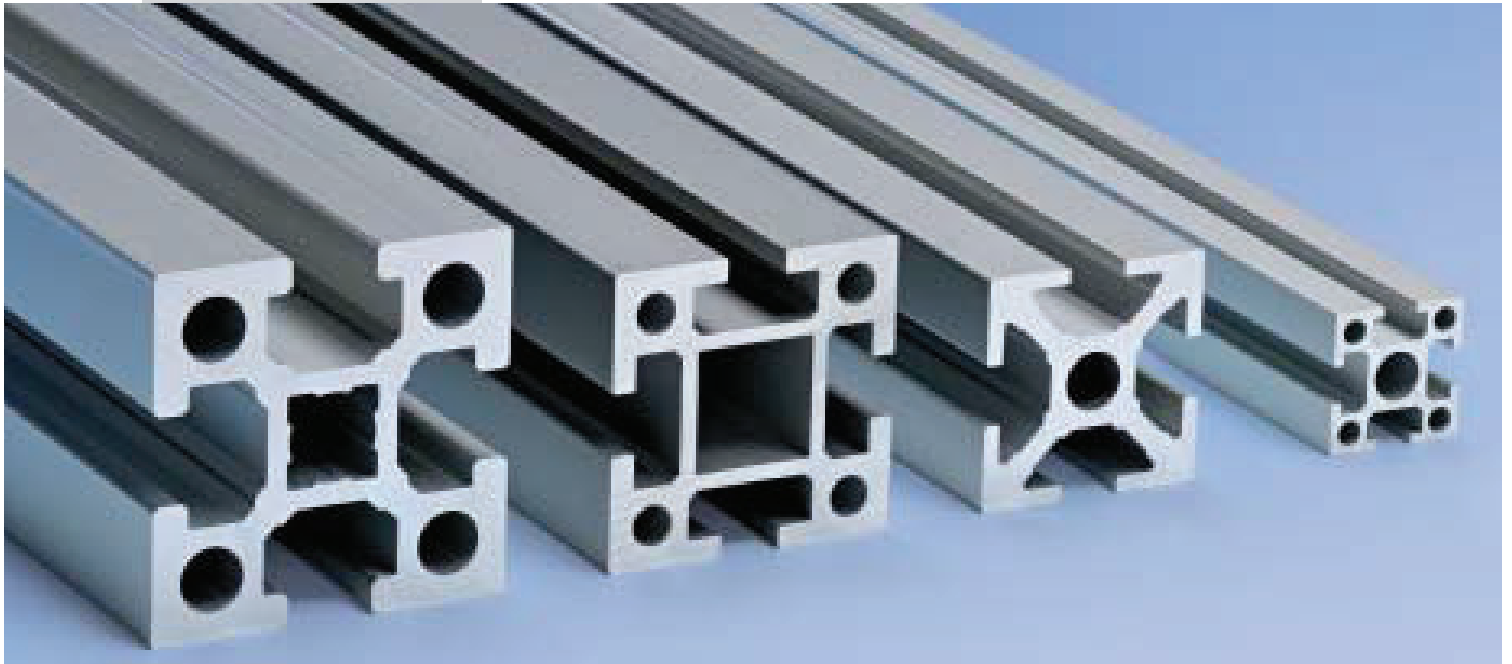

*"Our Profile Technology
product catalog"*

With mk profile technology you build using flexibility and established technology from the outset. With an excess of 250 system profiles made from high-quality alloys, perfected stable connectors, as well as a comprehensive range of accessories and compatible standardized components, you can realize virtually all structural designs for machine frames, guards and factory equipment. With four aluminum profile series – categorized according to the base



dimensions 25, 40, 50 and 60 mm – a perfect profile series is available for every application. Simple frames with small spatial requirements can be built just as effectively as load-bearing structures for heavy machinery. Our experienced engineers and customer-focused design aids such as the 3D configurator and online CAD library provide further support. The benefit that the mk system offers is an assembly that is substantially simpler for you due to the use

of standard components. You are able to focus on the functions rather than the design of individual components. You also profit from the compatibility of the profiles with each other. This means systems can be easily expanded or modified as and when necessary. Due to the high quality of the products and connectors, all components have a long life and can be reused after being disassembled.

Our Business Fields –
mk Conveyor Technology



*"Our Conveyor Technology
product catalog"*

There are three important factors to take into account when choosing the right conveyor technology: high process reliability, fast availability and a reasonable price. mk conveyor technology offers you all three of these benefits.

mk conveyor technology provides you with an extensive standardized range which enables precise matching of the individual modules

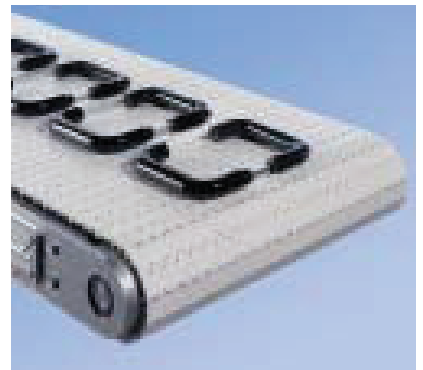

to their respective requirements. This ensures maximum process reliability. Our products include flat and timing belt conveyors, steel and plastic chain conveyors as well as roller conveyors. You can choose from a total of 20 conveyor systems. This enables your system to be designed precisely to the workpiece and the environment in which it is used. To do so, use our product com-

parison tool on the internet. Individual production processes and automation can be taken into account as well as specific customer requirements, i.e. integration within existing systems.

Thanks to standardization, our range is cost-effective, easy to expand and quickly available.

Our Business Fields –
mk Linear Motion

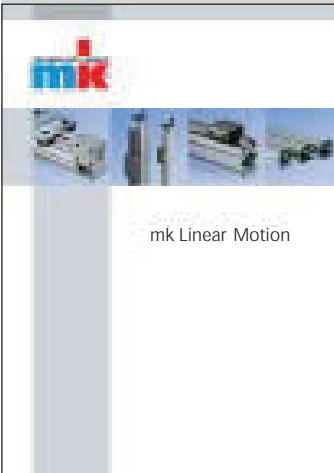
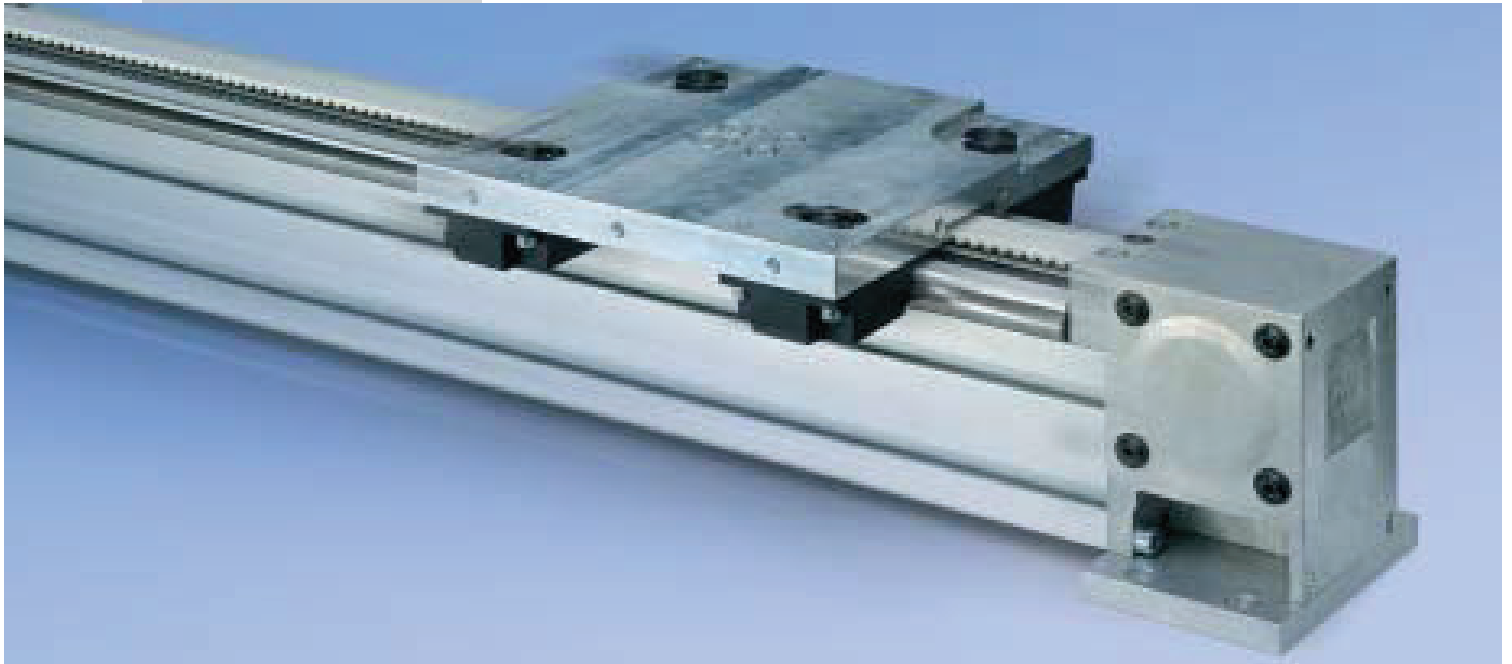

*"Our Linear Motion
product catalog"*

mk linear technology features customized linear systems which set themselves apart thanks to their high reliability in operation and precise running. Choose from a wide selection. With our add-on principle you can achieve limitless configuration options for linear functions. This results in an optimum design that is tailored



to your needs. We offer slide-ways, track roller guides and recirculating ball bearings. You can choose between profile tracks, linear tracks and linear modules for handling applications with high repeat accuracy. On request, carriages with pneumatic or electro-mechanical drive elements may also be

incorporated. An additional benefit: mk guides are compatible with all mk profile series. The add-on principle enables tracks to be mounted directly onto your system's load-bearing structure. You save on material, cost and space.

Our Business Fields –
mk Factory Equipment

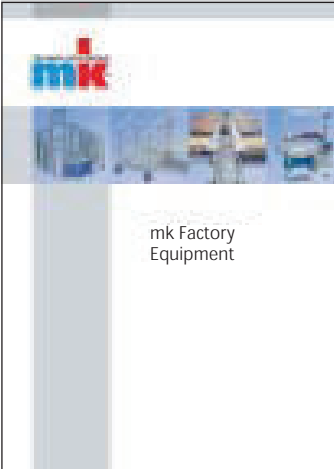

*"Our Factory Equipment
product catalog"*

Factory equipment from mk is characterized by modular equipment. Based on the basic technology of the mk profiles, you have an economic and comprehensive range of elements for individual factory equipment.

Your benefit: Due to the modular design you are completely flexible when it comes to designing your



workstations and work areas as functionally and ergonomically as possible. A module construction kit for enclosures with swing, sliding and lifting doors enables you to configure perimeter guards using a 3D configurator. If the conditions on site change, it is easy to modify or expand, even using the existing modules. In addition, the individual modules can be used to set up

individual workstations for the workshop, assembly areas or offices, which satisfy all aesthetic, functional and ergonomic requirements. Our modules are complemented by an extensive range of stylish and functional guard rails, stairs and platforms which enable you to complete the design of your plant layout from a single source.

How to use the Catalog

Series Icons

The following symbols identify the suitability of a particular component to its respective Profile Series. Any component not so identified is typically usable in all Profile Series.

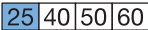
Symbol for Profile Series 25 

Symbol for Profile Series 40 

Symbol for Profile Series 40, limited use in Series 50 

Symbol for Profile Series 50, limited use in Series 40 

Symbol for Profile Series 50 

Symbol for Profile Series 60 

Symbols used for base dimensions and T-slot widths

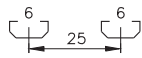

The symbols shown describe the profile series.

- The base dimension shows the square dimension of the smallest profile of the series. Larger profiles are always a

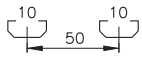
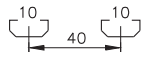

multiple of the base dimension.

- The distance between two parallel T-slots is also equal to the base dimension.
- Each base dimension is associated with a standard T-slot width.

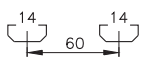

Symbols used for screws

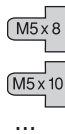

The symbols shown alongside this text describe the recommended dimensions of the screws (thread and screw length).



If special screws are required for the function, the appropriate norm is stated along with the screw symbol.

Cross-references for additional information

A blue bar with a cross-reference arrow indicates that additional information about the product or topic is available in another part of the catalog.

Reference in this chapter to another chapter.

 [see information on page XXX](#)

Pointers to additional information on this product that can be found in another chapter.

 [P. XXX](#)

Order number system

The numbering system is used to identify cut-to-length as well as stock length profiles.

Description

Profile mk 2040.01

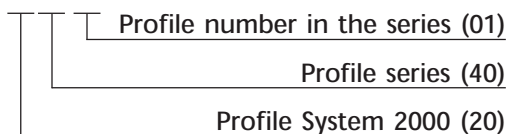

Order Number for Stock Length Profiles

54.01.5100

available stock length in mm

Order Number for Cut-to-Length Profiles

54.01. *

Profiles (four-digit) with the length in mm

Number in the series

Profile Series number

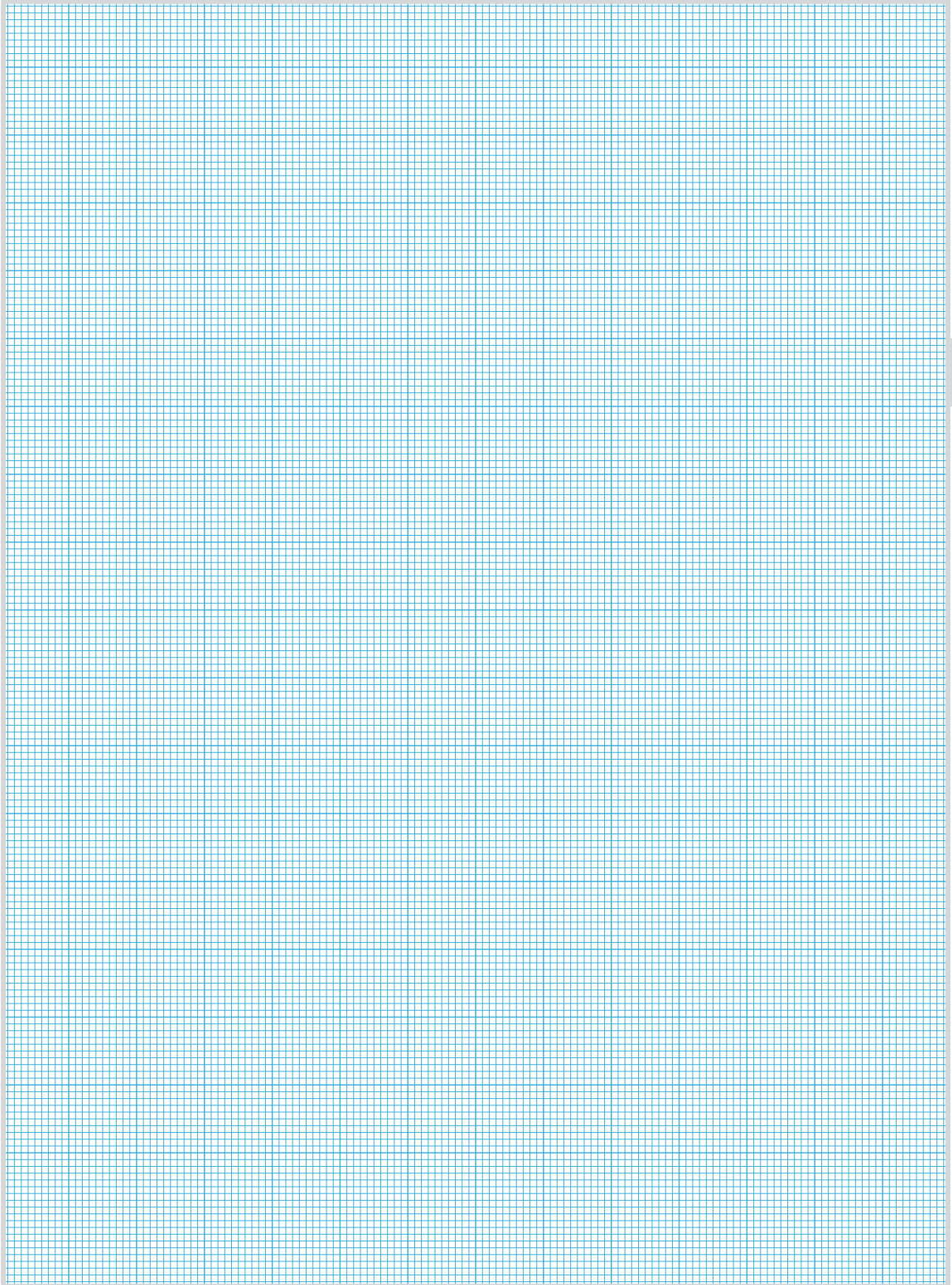

Information about Profile Technology

Advantages



Advantages of mk profile technology

- Widest profile range available on the market
- Mechanical engineering focused product philosophy (form follows function)
- Perfected, stability-oriented connectors
- Comprehensive range of accessories
- Competent advice from mk sales engineers
- Customer-focused aids such as online CAD library, electronic catalog and design documents
- Easy assembly
- Use of high-quality materials
- Disassembled elements can be reused
- Degree of assembly freely selectable: mk supplies individual components, construction kits, assemblies and modules
- Customer studies confirm that mk profile technology has the highest strength per price

General advantages of Profile Technology

The use of mk aluminum profile technology in mechanical engineering offers a large number of advantages compared to other systems:

■ On the one hand, the use of

standard elements enables short planning, design and assembly times.

■ On the other hand, the use of removable connectors ensures that the disassembled elements

can be reused.

■ And last, but not least, use of high-quality aluminum alloys results in high load-bearing capacity despite the low weight of the profiles themselves.



No flame cutting and welding necessary

- Smart connections using threaded connectors
- Profiles and components can be reused after disassembly



No grinding and polishing necessary

- Braces and beams can be easily removed or relocated
- Assembly changes can be made without visible traces and damage



No painting necessary

- Clean surfaces
- Attractive finish

Advantages of the mk connection methods

mk profile technology sets itself apart, among other things, by various modern connection methods. Unlike other systems, mk is a proponent of the "cut and assemble" philosophy. Therefore, simply

cut to the right length, bolt together – finished. Besides cutting the profiles to the desired lengths, you may at most need a standard hand drill and/or tap. You do not need to purchase expensive

special tools. The user can easily cut to length, prepare, and assemble the profiles themselves. The mk production team would, of course, be happy to take on this task for you.

Using the mk profile technology system

Working with the profile technology construction kit





The mk profile technology construction kit is the widest system on the market and is available for

your design needs. The following explanations assist you with the construction procedure.

1. Selecting the profile

The mk 2000 profile system consists of four profile series which are compatible with each other and are designed for different applications. The choice of profile series will depend on the type of application, the load-bearing capacity and design requirements as well as the spatial conditions on site. See the table below for more detailed information.



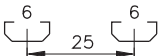
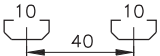
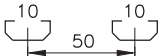
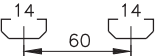
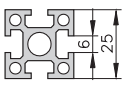
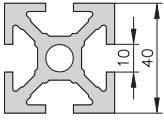
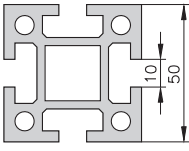
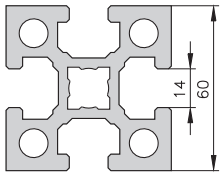

| |  |  |  |  |
|----------------------------|--|--|--|---|
| | Series 25 | Series 40 | Series 50 | Series 60 |
| Symbols |  |  |  |  |
| Versions | Normal | Normal, light, extra light | Normal, light | Normal |
| Material | EN AW 6063 T66 AlMgSi 0,5 F25 | EN AW 6063 T66 AlMgSi 0,5 F25 | EN AW 6005A T6 AlMgSi 0,7 F28 | EN AW 6005 AT6 AlMgSi 0,7 F28 |
| Classic applications | Lightweight frames, display cases, display cabinets, fixtures, measuring and test equipment, control and electronic cabinets | Light to medium duty machine, frames, guarding, assembly workstations, show booths, work platforms | Heavier machine frames, load-bearing structures | Machine frames with maximum loads, mezzanines |
| Base dimensions |  25 x 25 mm |  40 x 40 mm |  50 x 50 mm |  60 x 60 mm |
| Largest dimensions | 25 x 150 mm or 50 x 50 mm | 160 x 160 mm | 50 x 200 mm or 100 x 100 mm | 120 x 240 mm |
| Standard mounting hardware | M5 | M8 | M8 | M12 |

2. Selecting the connectors

The mk construction kit offers you all degrees of freedom in the design. It is possible to realize both 90° connections as well as connections with freely selected angles. The most important criteria for choosing the correct connection for your design are given in the following table.

mk does not use custom bolts or screws in its construction kit. All attachments can be made using standard hardware. The result is economical connections using standard tools.

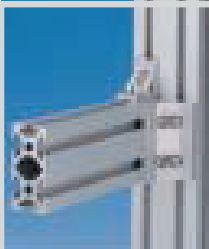

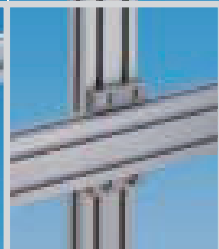
| |  |  |  |  |  |
|---------------------|--|--|---|--|--|
| | <i>Tension plugs</i> | <i>Angles</i> | <i>Corner blocks</i> | <i>Plate</i> | <i>Clamps</i> |
| Locking element | no | yes | no | yes | no |
| T-slots remain free | yes | no | no | no | no |
| Loading capacity | average | high | average | high | average |
| Service required | yes | no | yes | no | no |

3. Selecting the accessory components



The mk construction kit contains a large range of accessory elements. After selecting the profile and connection elements, the designs are completed for your particular requirements. The elements are generally suitable for a variety of profile series.



mk Structural Profiles

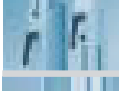

Contents mk Structural Profiles

| | | |
|---|------------------------------------|----|
|  | System 2000 Series 25 | 30 |
|  | System 2000 Series 40 | 36 |
|  | System 2000 Series 50 | 54 |
|  | System 2000 Series 60 | 60 |
|  | Profiles for Telescoping Series 40 | 46 |
|  | Profiles for Telescoping Series 50 | 58 |
|  | Profiles for Sliding Windows | 63 |
|  | Profiles for Sheets and Paneling | 64 |
|  | Profiles for Swing Door Stops | 65 |
|  | Profiles for Floors and Steps | 66 |
|  | Foamed Profiles | 68 |
|  | Profile Services | |
|  | Curved Profiles | 72 |
|  | End Services | 74 |
|  | Threads and Inserts | 81 |

Structural Profiles

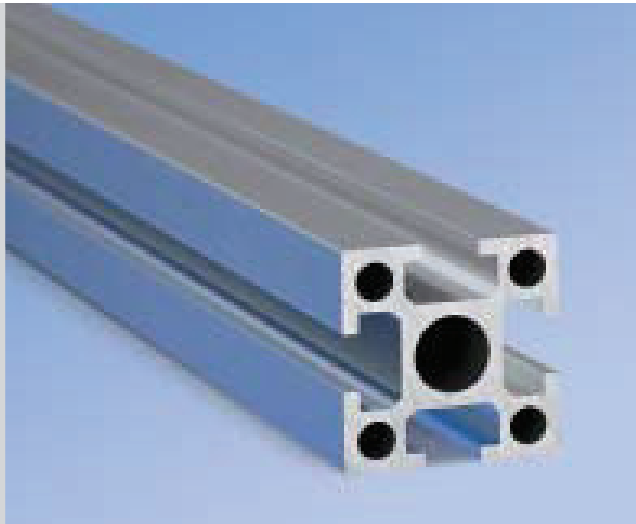

System 2000 Series 25 

Series 25 Dimensions and Threads

Series 25 is designed on a 25 x 25 mm base dimension. The 6 mm T-slots are spaced at 25 mm. Threads can be cut into the extruded holes.

 Profile services see page 74

Profile ends can be tapped directly.  P. 224

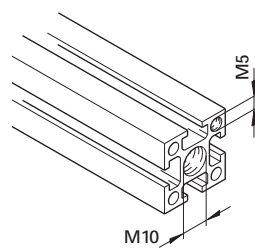

Recommended screw length = $2 \cdot d_N$

Other threads possible with inserts.  P. 81

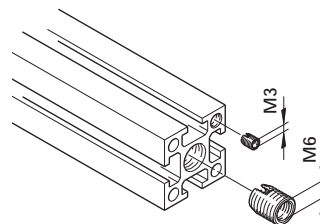

Threaded Insert M3
K112030002

Threaded Insert M6
K112030006

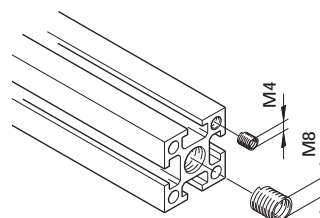

Helicoil M4
K112030104

Helicoil M8
K112030109

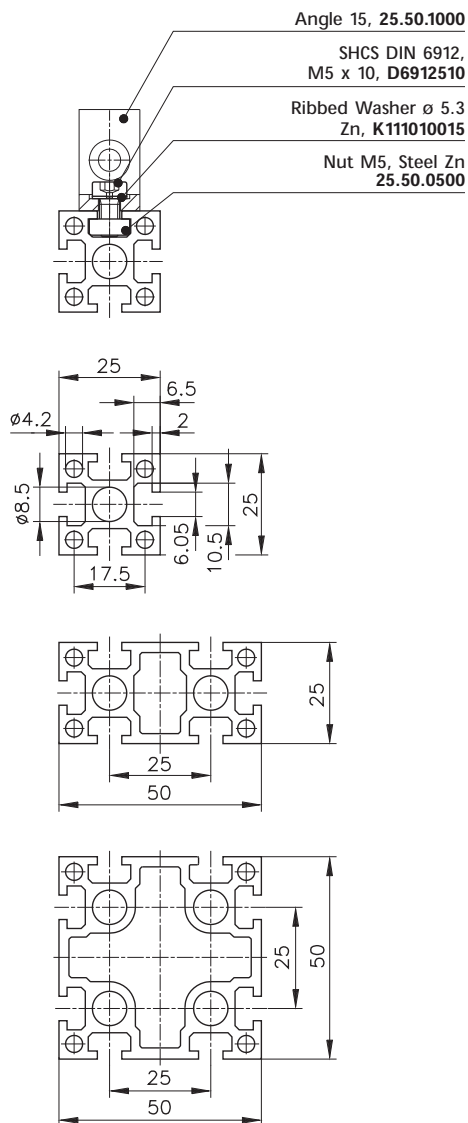

d_N = Thread diameter



System 2000 Series 25 

Series 25

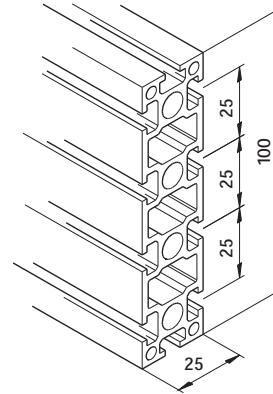

Profile mk 2025.03

2.55 kg/m
 AlMgSi 0.5 F25

Stock length **25.03.5100**

Cut **25.03.***

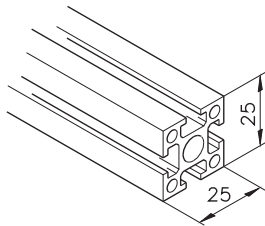

Profile mk 2025.01

0.75 kg/m
 AlMgSi 0.5 F25

Stock length **25.01.5100**

Cut **25.01.***

Services **from page 74**

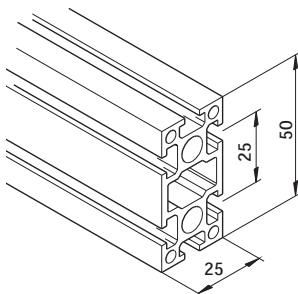

Profile mk 2025.02

1.35 kg/m
 AlMgSi 0.5 F25

Stock length **25.02.5100**

Cut **25.02.***

Services **from page 74**

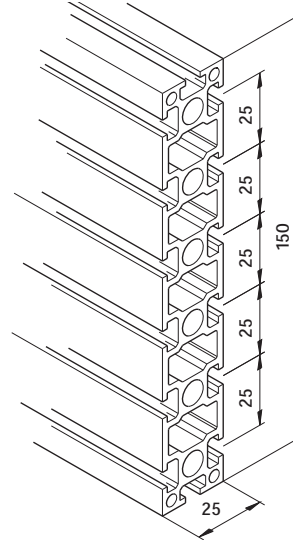

Profile mk 2025.04

3.75 kg/m
 AlMgSi 0.5 F25

Stock length **25.04.5100**

Cut **25.04.***

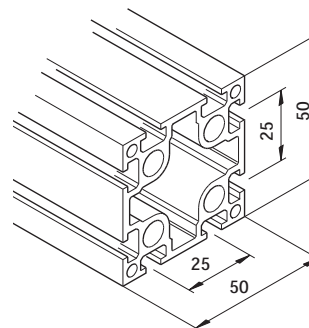

Profile mk 2025.05

2.21 kg/m
 AlMgSi 0.5 F25

Stock length **25.05.5100**

Cut **25.05.***

Services **from page 74**

Structural Profiles

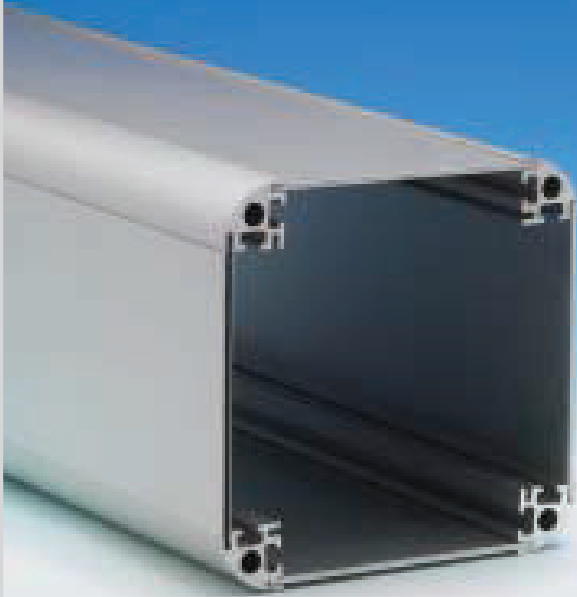

System 2000 Series 25 

Series 25 with closed T-slots

In addition to the standard system T-slot, the profiles of Series 25 with closed T-slots have a second, smaller slot which can accept paneling. This paneling can be recessed or reworked to be flush with the framing.

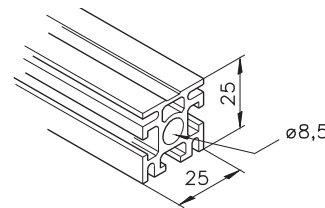
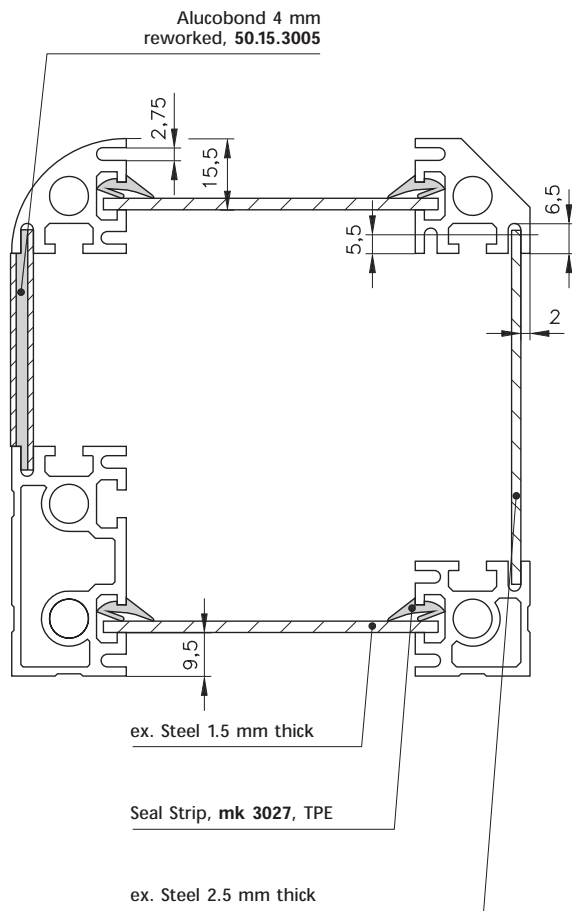

Profile mk 2025.31

0.77 kg/m
AlMgSi 0.5 F25

Stock length **25.31.5100**

Cut **25.31.***

Services from page 74

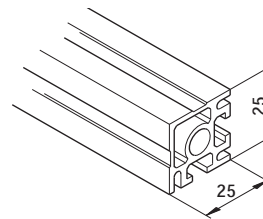

Profile mk 2025.35

0.75 kg/m
AlMgSi 0.5 F25

Stock length **25.35.5100**

Cut **25.35.***

Services from page 74

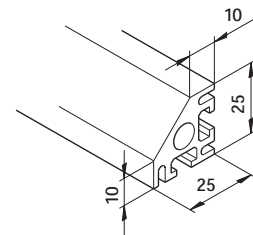

Profile mk 2025.38

0.79 kg/m
AlMgSi 0.5 F25

Stock length **25.38.5100**

Cut **25.38.***

Services from page 74

....* Profile length in mm

System 2000 Series 25 

Series 25 with closed T-slots

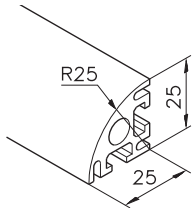

Profile mk 2025.37
 0.73 kg/m
 AlMgSi 0.5 F25
 Stock length **25.37.5100**
 Cut **25.37. ***
 Services from page 74

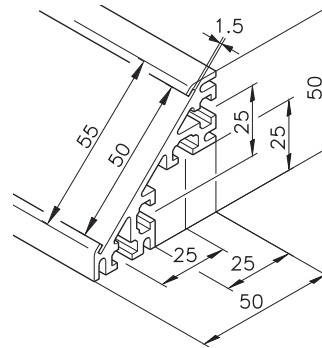

Profile mk 2025.25
 1.30 kg/m
 AlMgSi 0.5 F25
 Stock length **25.25.5100**
 Cut **25.25. ***

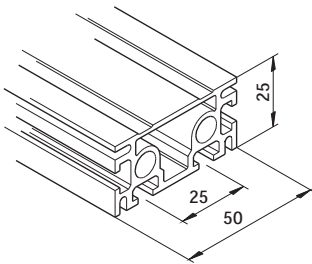

Profile mk 2025.32
 1.29 kg/m
 AlMgSi 0.5 F25
 Stock length **25.32.5100**
 Cut **25.32. ***
 Services from page 74

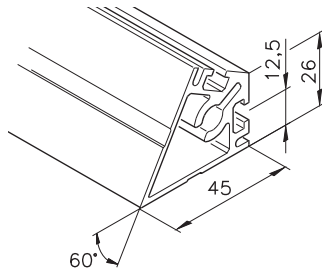

Profile mk 2025.16
 1.13 kg/m
 AlMgSi 0.5 F25
 Stock length **25.16.5100**
 Cut **25.16. ***

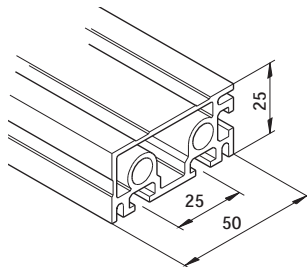

Profile mk 2025.36
 1.25 kg/m
 AlMgSi 0.5 F25
 Stock length **25.36.5100**
 Cut **25.36. ***
 Services from page 74

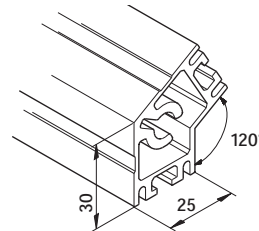

Profile mk 2025.17
 1.24 kg/m
 AlMgSi 0.5 F25
 Stock length **25.17.5100**
 Cut **25.17. ***

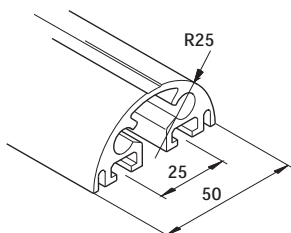

Profile mk 2025.39
 1.1 kg/m
 AlMgSi 0.5 F25
 Stock length **25.39.5100**
 Cut **25.39. ***
 Services from page 74

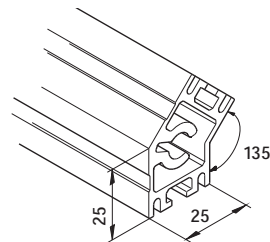

Profile mk 2025.18
 1.02 kg/m
 AlMgSi 0.5 F25
 Stock length **25.18.5100**
 Cut **25.18. ***

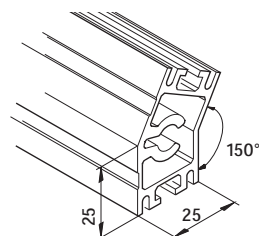

Profile mk 2025.19
 1.23 kg/m
 AlMgSi 0.5 F25
 Stock length **25.19.5100**
 Cut **25.19. ***

....* Profile length in mm

Structural Profiles

System 2000 Series 25  25 

Series 25

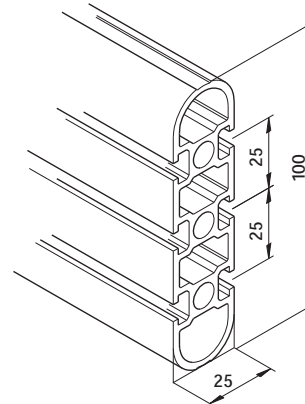
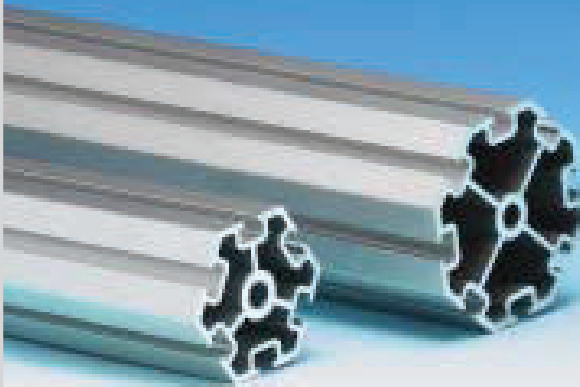

Profile mk 2025.22

2.26 kg/m

AlMgSi 0.5 F25

Stock length **25.22.5100**

Cut **25.22.***

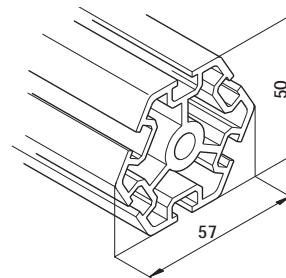

Profile mk 2025.20

2.12 kg/m

AlMgSi 0.5 F25

Stock length **25.20.5100**

Cut **25.20.***

Services **from page 74**

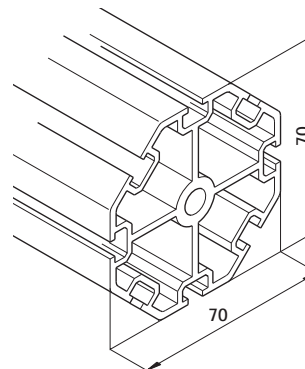

Profile mk 2025.21

2.98 kg/m

AlMgSi 0.5 F25

Stock length **25.21.5100**

Cut **25.21.***

Services **from page 74**

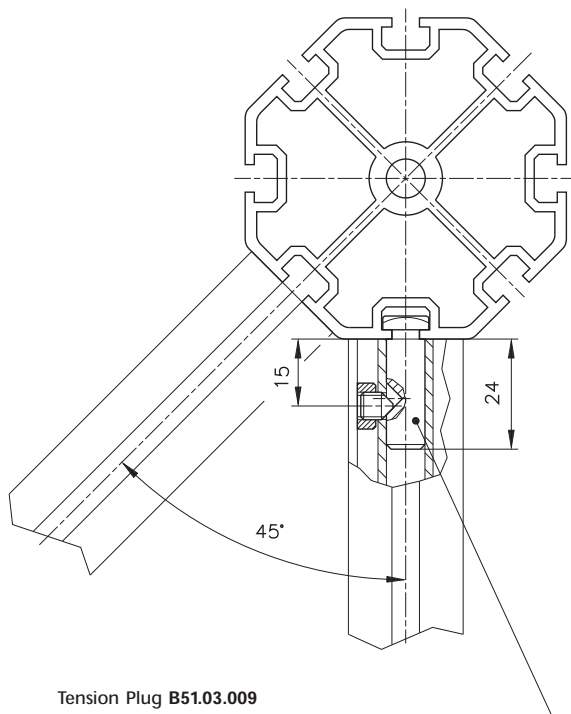

Tension Plug B51.03.009

 **P. 108**

....* Profile length in mm

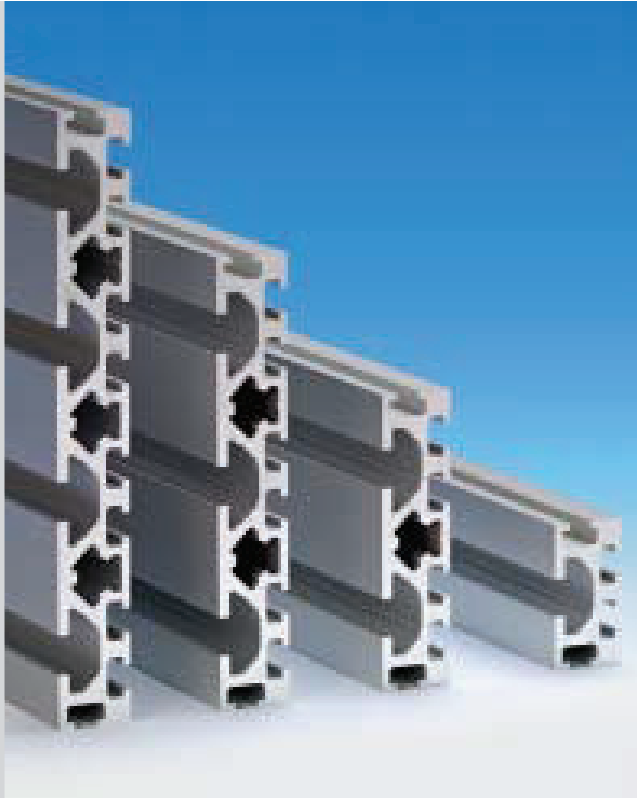

System 2000 Series 25 

Adapter Profiles from series 25 to series 40

One profile side has series 25 T-slots; the other profile side has series 40 T-slots. This makes it possible to combine elements from series 25 and 40. Applications include:

- Locations within larger frames for small, series 25 access windows.
- As mounting locations for valve banks.

Threaded Insert M8
 K112030008

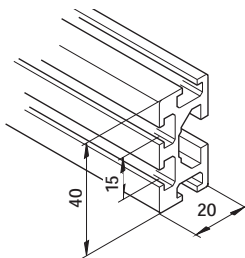
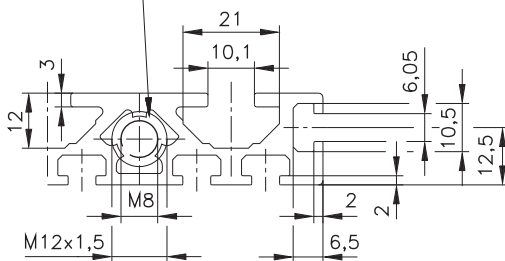

Profile mk 2025.41

1.02 kg/m
 AlMgSi 0.5 F25

Stock length **25.41.5100**

Cut **25.41.***

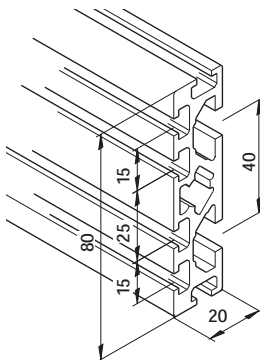

Profile mk 2025.42

1.94 kg/m
 AlMgSi 0.5 F25

Stock length **25.42.5100**

Cut **25.42.***

Services from page 74

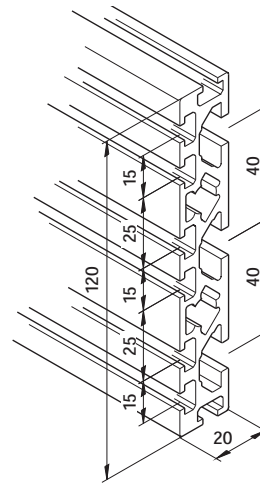

Profile mk 2025.43

2.86 kg/m
 AlMgSi 0.5 F25

Stock length **25.43.5100**

Cut **25.43.***

Services from page 74

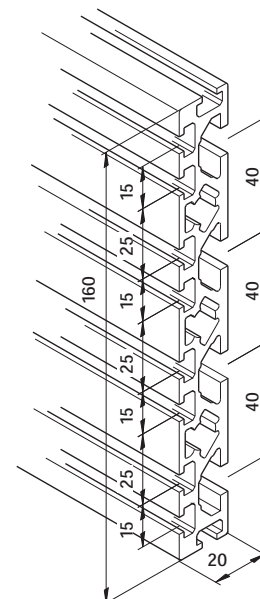

Profile mk 2025.44

3.77 kg/m
 AlMgSi 0.5 F25

Stock length **25.44.5100**

Cut **25.44.***

Services from page 74

....* Profile length in mm

Structural Profiles

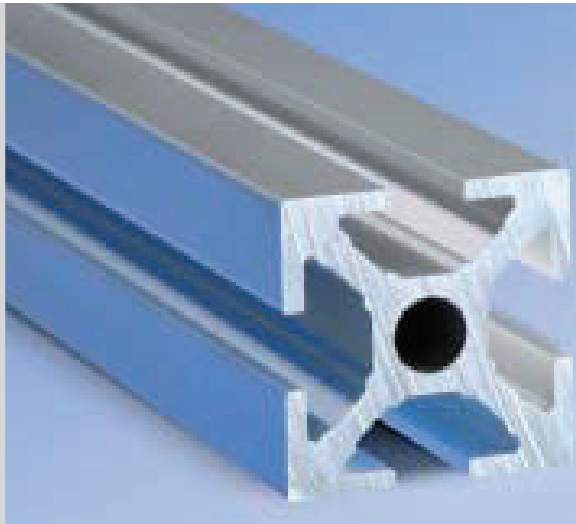

System 2000 Series 40 

Series 40 Dimensions and Threads

Series 40 is designed on a 40 x 40 mm base dimension. The 10 mm T-slots are spaced at 40 mm. Threads can be cut into the extruded holes.

 Profile services see page 74

Profile ends can be tapped directly.  P. 224

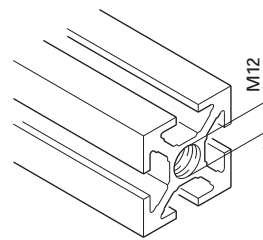

Recommended screw length = $2 \cdot d_N$

Other threads possible with inserts.  P. 81

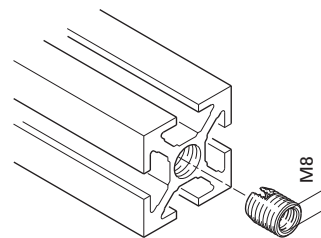

Threaded Insert M8
K112030008

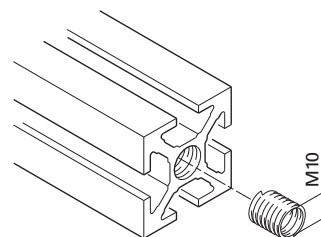

Helicoil M10
K112030110

d_N = Thread diameter

Angle E25, 82.40.0701

SHCS,
M8 x 16, D0912816

Ribbed Washer ϕ 8.4
Zn, K111010017

Nut 1 M8, Steel Zn 34.01.0001

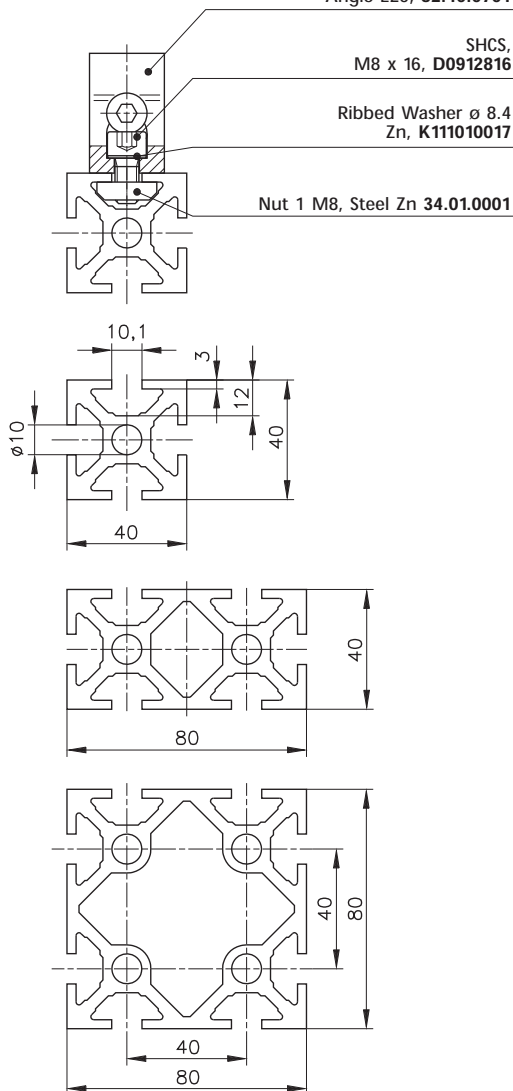

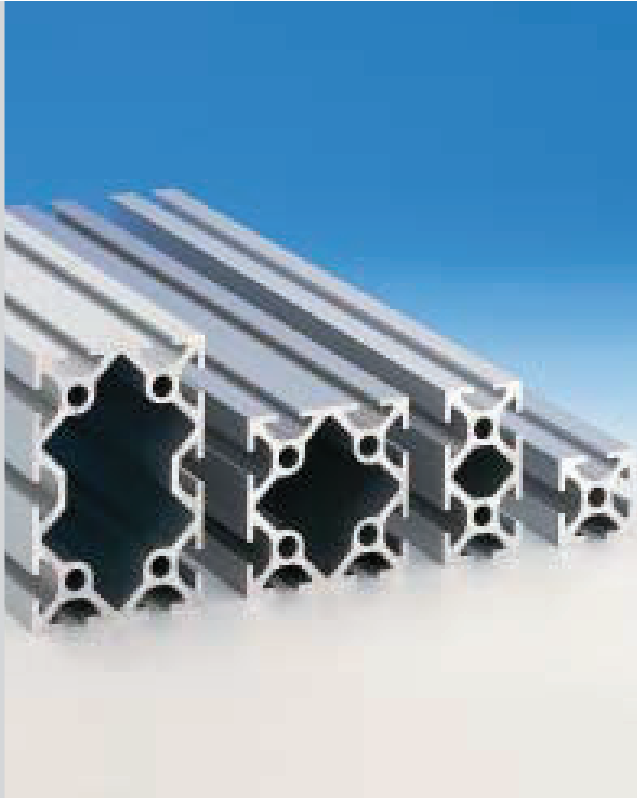

System 2000 Series 40 

Series 40

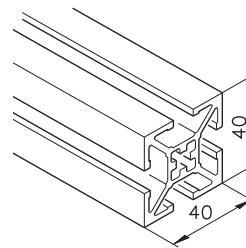

**Profile mk 2040.31
(extra light)**

1.50 kg/m
 AlMgSi 0.5 F25

Stock length **54.31.5100**

Cut **54.31. ***

Services from page 74

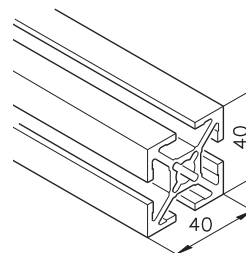

**Profile mk 2040.40
(light)**

1.64 kg/m
 AlMgSi 0.5 F25

Stock length **54.40.5100**

Cut **54.40. ***

Services from page 74

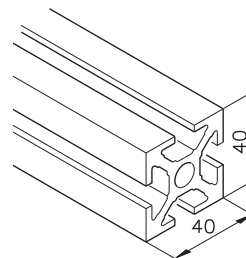

Profile mk 2040.01

2.00 kg/m
 AlMgSi 0.5 F25

Stock length **54.01.5100**

Stock length **54.01.6100**

Cut **54.01. ***

Services from page 74

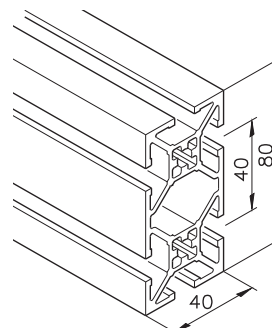

**Profile mk 2040.52
(extra light)**

2.67 kg/m
 AlMgSi 0.5 F25

Stock length **54.52.5100**

Cut **54.52. ***

Services from page 74

 P. 224

extra light profiles

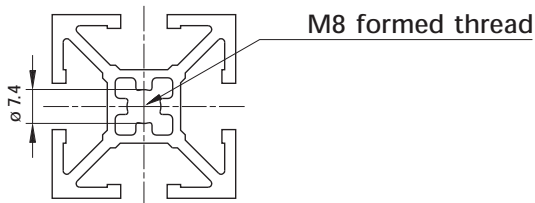

light profiles

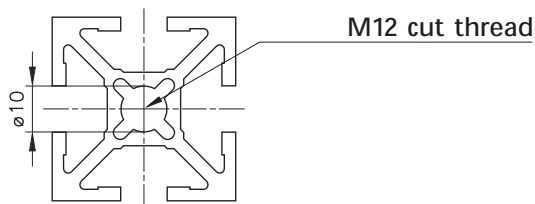

standard profiles

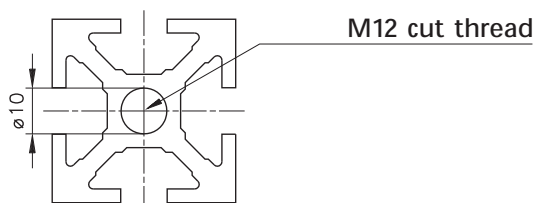

....* Profile length in mm

Structural Profiles

System 2000 Series 40 

Series 40

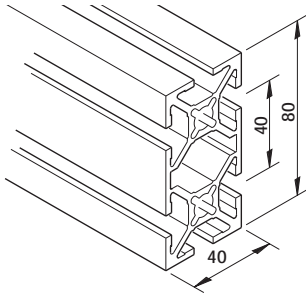

Profile mk 2040.41 (light)

2.85 kg/m
AlMgSi 0.5 F25

Stock length **54.41.5100**

Cut **54.41.***

Services from page 74

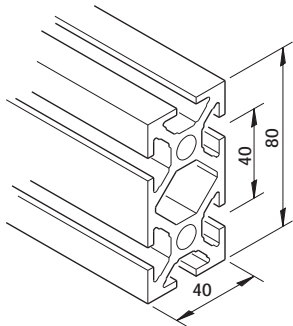

Profile mk 2040.02

3.62 kg/m
AlMgSi 0.5 F25

Stock length **54.02.5100**

Stock length **54.02.6100**

Cut **54.02.***

Services from page 74

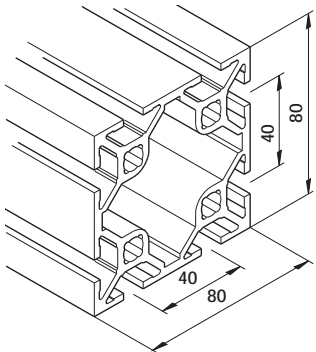

Profile mk 2040.45 (light)

4.75 kg/m
AlMgSi 0.5 F25

Stock length **54.45.5100**

Stock length **54.45.6100**

Cut **54.45.***

Services from page 74

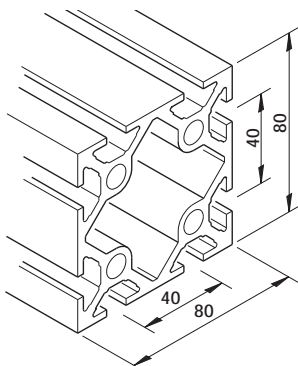

Profile mk 2040.03

5.57 kg/m
AlMgSi 0.5 F25

Stock length **54.03.5100**

Stock length **54.03.6100**

Cut **54.03.***

Services from page 74

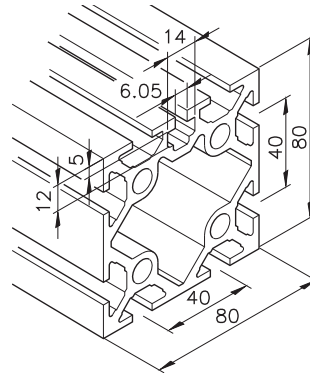

Profile mk 2040.73

5.72 kg/m
AlMgSi 0.5 F25

Stock length **54.73.5100**

Cut **54.73.***

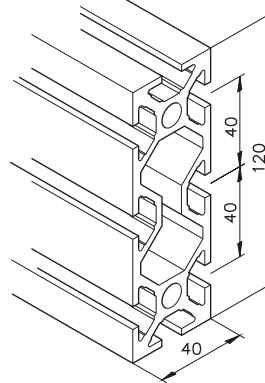

Profile mk 2040.05

4.69 kg/m
AlMgSi 0.5 F25

Stock length **54.05.5100**

Cut **54.05.***

Services from page 74

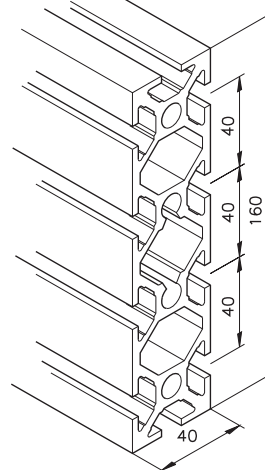

Profile mk 2040.06

6.26 kg/m
AlMgSi 0.5 F25

Stock length **54.06.5100**

Cut **54.06.***

Services from page 74

....* Profile length in mm

System 2000 Series 40 

Series 40

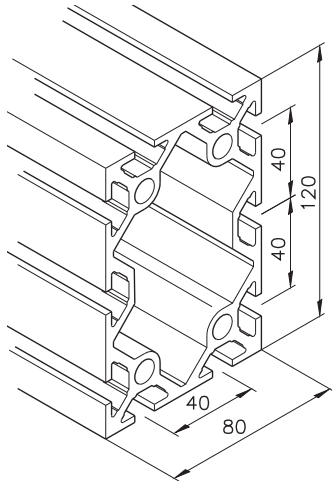

Profile mk 2040.07

6.96 kg/m

AlMgSi 0.5 F25

Stock length **54.07.5100**

Stock length **54.07.6100**

Cut **54.07.***

Services **from page 74**

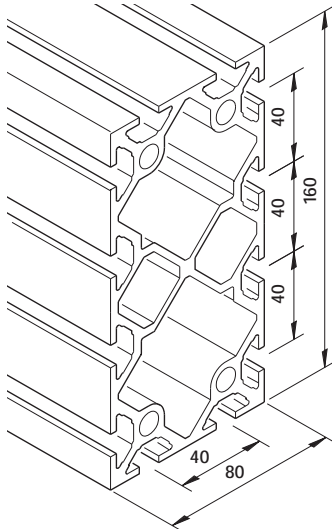

Profile mk 2040.08

9.46 kg/m

AlMgSi 0.5 F25

Stock length **54.08.5100**

Stock length **54.08.6100**

Cut **54.08.***

Services **from page 74**

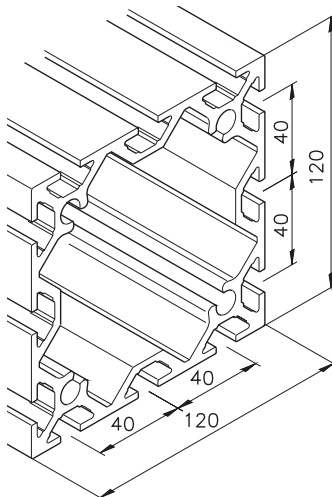

Profile mk 2040.10

8.26 kg/m

AlMgSi 0.5 F25

Stock length **54.10.5100**

Cut **54.10.***

Services **from page 74**

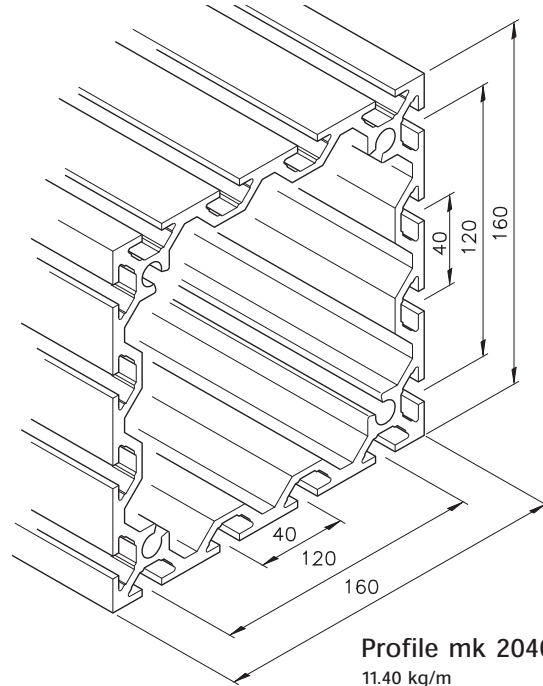

Profile mk 2040.09

11.40 kg/m

AlMgSi 0.5 F25

Stock length **54.09.5100**

Cut **54.09.***

Services **from page 74**

....* Profile length in mm

Structural Profiles



System 2000 Series 40 

Series 40 with closed T-slots

In addition to the standard system T-slot, the profiles of Series 40 with closed T-slots have a second, smaller slot which can accept paneling. This paneling can be recessed or reworked to be flush with the framing.

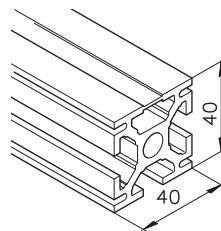
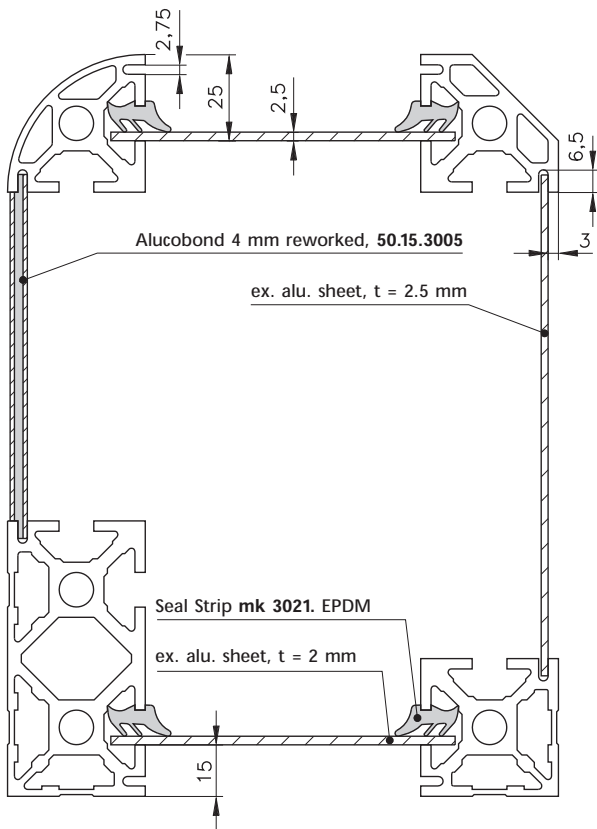

Profile mk 2040.21

1.84 kg/m
AlMgSi 0.5 F25

Stock length **54.21.5100**

Cut **54.21. ***

Services from page 74

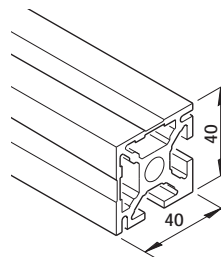

Profile mk 2040.11

1.88 kg/m
AlMgSi 0.5 F25

Stock length **54.11.5100**

Cut **54.11. ***

Services from page 74

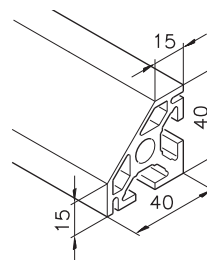

Profile mk 2040.14

1.62 kg/m
AlMgSi 0.5 F25

Stock length **54.14.5100**

Cut **54.14. ***

Services from page 74

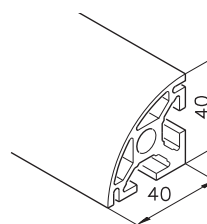

Profile mk 2040.15

1.51 kg/m
AlMgSi 0.5 F25

Stock length **54.15.5100**

Cut **54.15. ***

Services from page 74

....* Profile length in mm

System 2000 Series 40 

Series 40 with closed T-slots

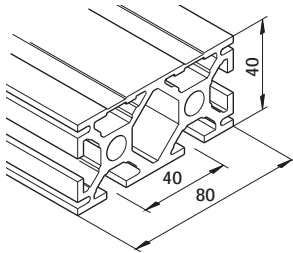

Profile mk 2040.22

3.43 kg/m

AlMgSi 0.5 F25

Stock length **54.22.5100**

Cut **54.22.***

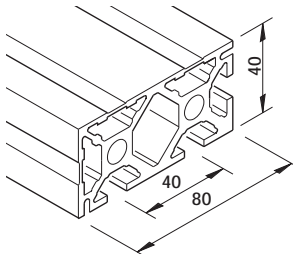

Profile mk 2040.12

3.43 kg/m

AlMgSi 0.5 F25

Stock length **54.12.5100**

Cut **54.12.***

Services **from page 74**

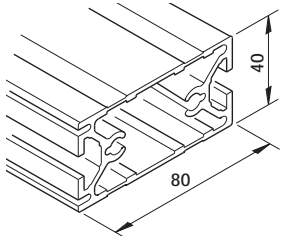

Profile mk 2040.24

2.25 kg/m

AlMgSi 0.5 F25

Stock length **54.24.5100**

Cut **54.24.***

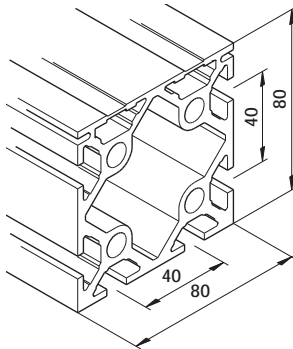

Profile mk 2040.46

5.44 kg/m

AlMgSi 0.5 F25

Stock length **54.46.5100**

Cut **54.46.***

Services **from page 74**

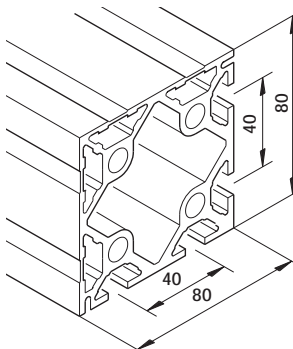

Profile mk 2040.13

5.32 kg/m

AlMgSi 0.5 F25

Stock length **54.13.5100**

Cut **54.13.***

Services **from page 74**

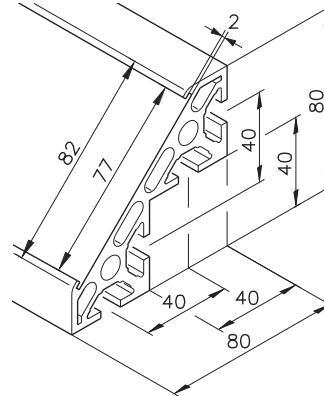

Profile mk 2040.04

3.61 kg/m

AlMgSi 0.5 F25

Stock length **54.04.5100**

Cut **54.04.***

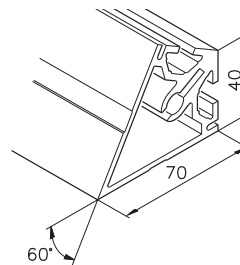

Profile mk 2040.17

2.64 kg/m

AlMgSi 0.5 F25

Stock length **54.17.5100**

Cut **54.17.***

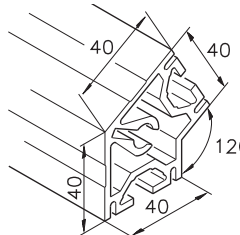

Profile mk 2040.18

2.45 kg/m

AlMgSi 0.5 F25

Stock length **54.18.5100**

Cut **54.18.***

 **P. 125**

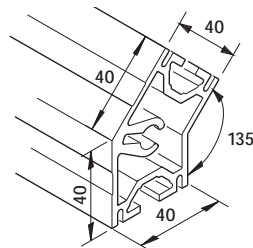

Profile mk 2040.19

2.54 kg/m

AlMgSi 0.5 F25

Stock length **54.19.5100**

Cut **54.19.***

 **P. 125**

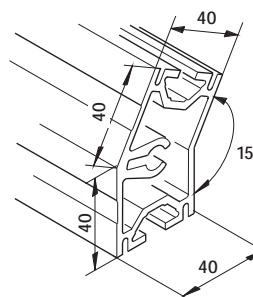

Profile mk 2040.20

2.62 kg/m

AlMgSi 0.5 F25

Stock length **54.20.5100**

Cut **54.20.***

 **P. 125**

....* Profile length in mm

Structural Profiles

System 2000 Series 40 

Cleanroom Profiles Series 40

These profiles are identified by their smooth exterior surfaces. The absence of any gaps gives contaminants no place to accumulate. The profiles are further designed to be completely standard system profiles, which is to say that they can be used with all assembly components.



Plug black, **K117010001** or Plug natural, **K117010046**

SHCS DIN 6912, M8 x 20, Stainless Steel **D6912820A2**

Spring Washer, $\varnothing 8.4$, Stainless Steel **D67968.4A2**

Threaded Insert M8, Stainless Steel **K112030020**

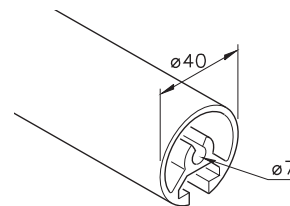
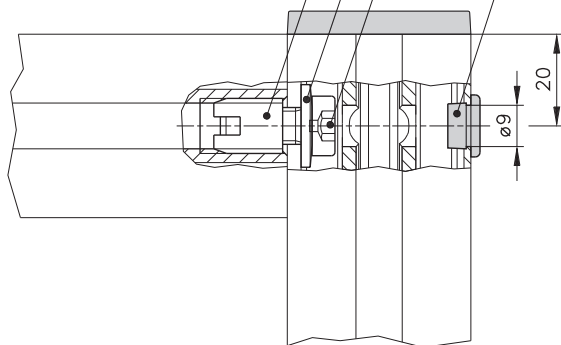

Profile mk 2040.16

1.25 kg/m
AlMgSi 0.5 F25

Stock length **54.16.5100**

Cut **54.16.***

Services **from page 74**

M8 Thread possible

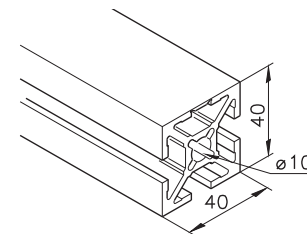

Profile mk 2040.92

1.68 kg/m
AlMgSi 0.5 F25

Stock length **54.92.5100**

Cut **54.92.***

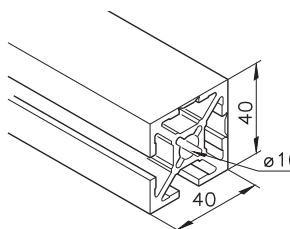

Profile mk 2040.93

1.72 kg/m
AlMgSi 0.5 F25

Stock length **54.93.5100**

Cut **54.93.***

....* Profile length in mm

System 2000 Series 40 

Cleanroom Profiles Series 40

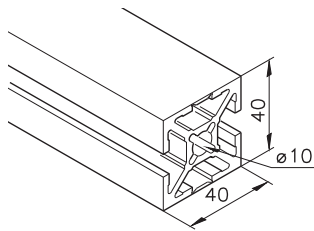

Profile mk 2040.94

1.72 kg/m
 AlMgSi 0.5 F25

Stock length **54.94.5100**

Cut **54.94.***

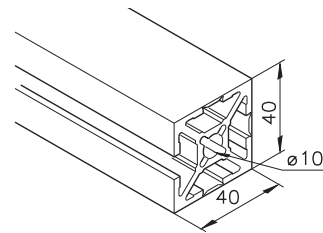

Profile mk 2040.95

1.75 kg/m
 AlMgSi 0.5 F25

Stock length **54.95.5100**

Cut **54.95.***

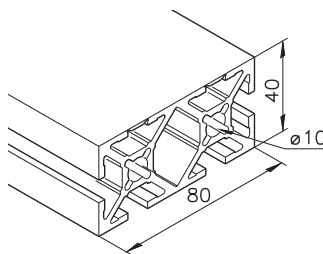

Profile mk 2040.100

2.94 kg/m
 AlMgSi 0.5 F25

Stock length **54.100.5100**

Cut **54.100.***

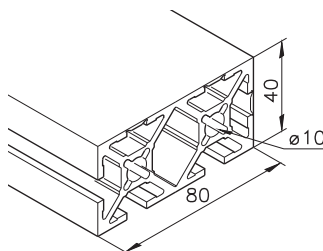

Profile mk 2040.101

2.97 kg/m
 AlMgSi 0.5 F25

Stock length **54.101.5100**

Cut **54.101.***

Structural Profiles

System 2000 Series 40 

Cleanroom Profiles Series 40 Services

The T-slot can be opened, either partially or completely, with very little effort. In this instance, the T-slot cover can be removed with the parting tool. Designed exclusively for use with mk profiles, very little force is required. If a partial removal of the cover is desired, we recommend placing a drilled hole at the exact location using our drill fixture.



Drill

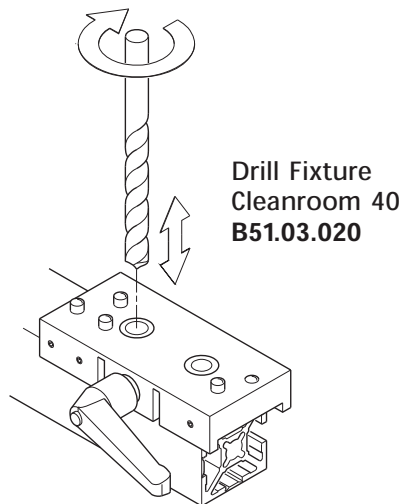

 Drill Fixtures see page 228

Deburr

Manual deburring can be easily carried out during the assembly process using a deburring block.

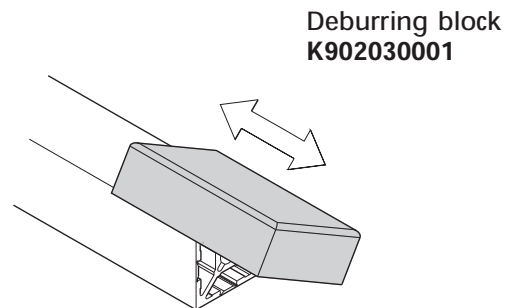

Part

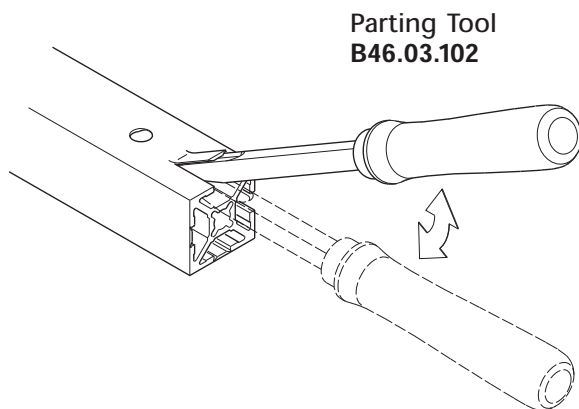

Profiles with Angle

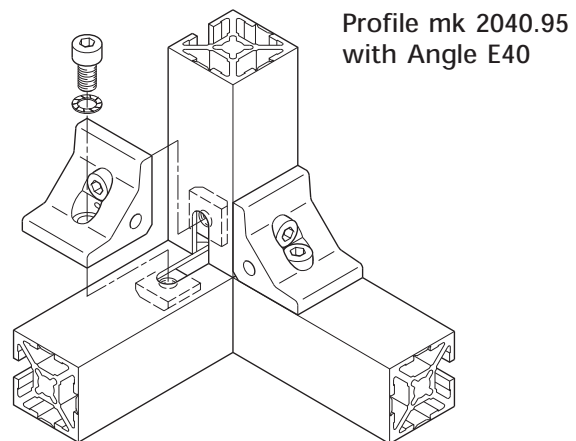

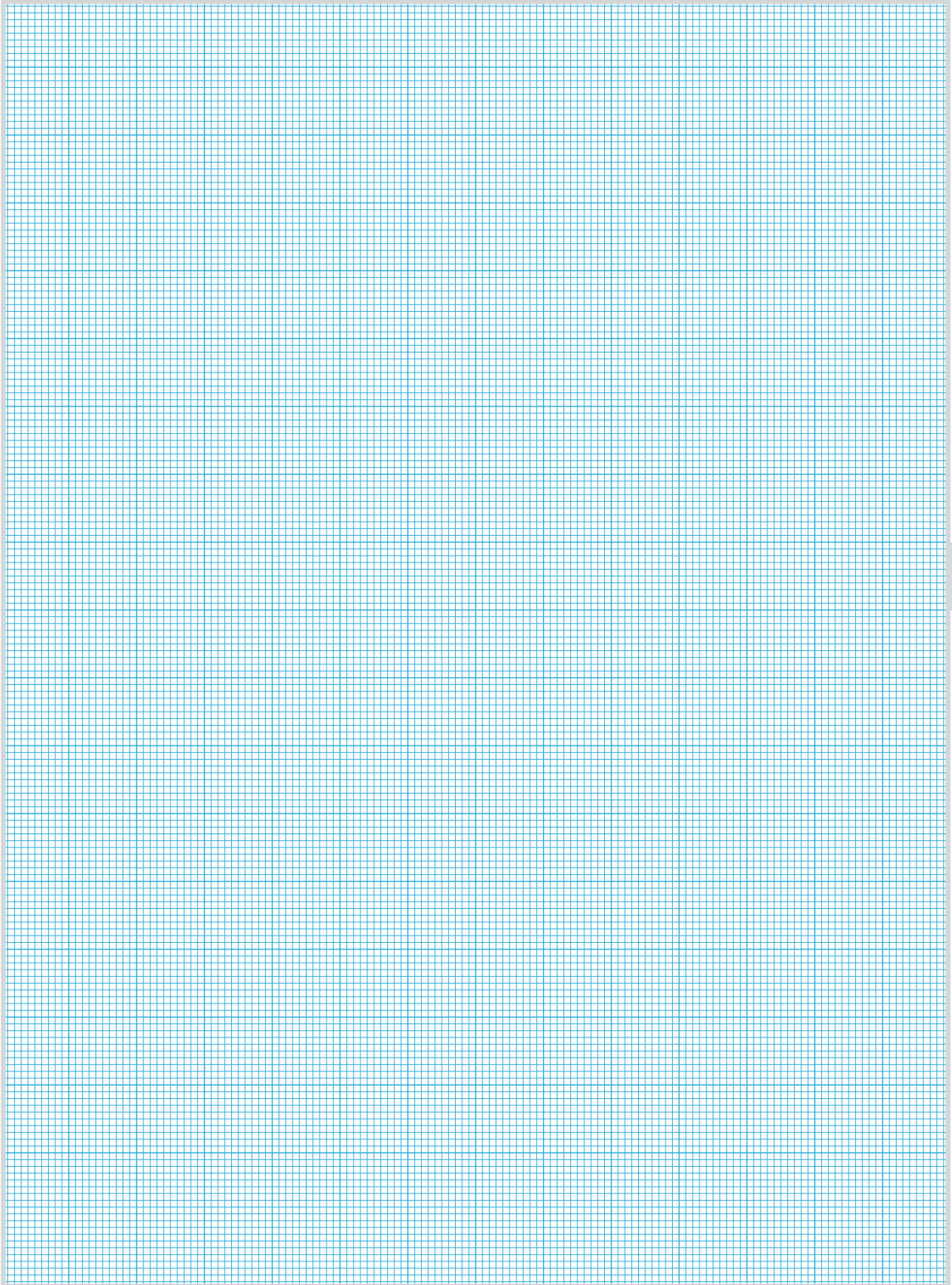

Structural Profiles

System 2000 Series 40 

Profiles for Telescoping Series 40

In combination with base Profile 40 x 40 mm, height adjustment for workstations and frames is quickly and simply accomplished. Profiles can be serviced to your request (cut, drill, tap or mill).



Guide mk 2575

SHCS M5 x 16 D0912516

Threaded Insert M5
K112030005

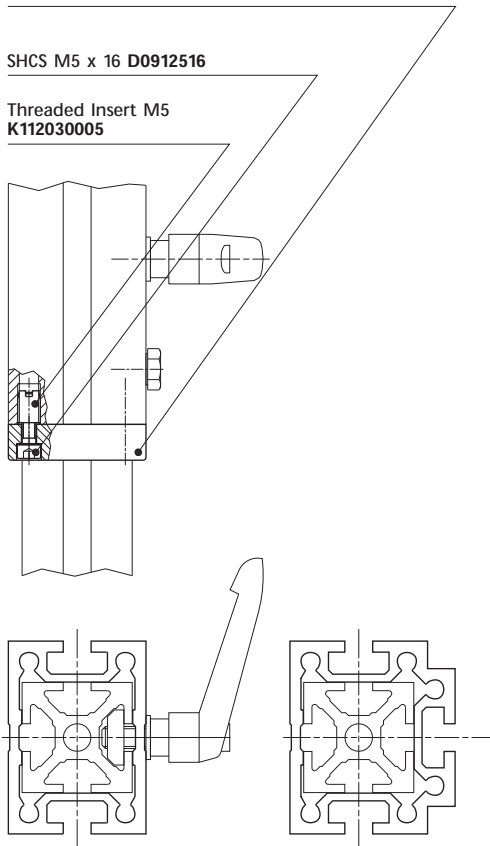

Guide PA6 19.02.0022

Adjustable Handle, Plastic
K110030204

FBH-Screw M8 x 16
K112010003

Nut 1 PE M8 34.01.0018

Guide mk 2575

Ribbed Washer \varnothing 5.3
K111010015, Steel Zn

SHCS M5 x 16
D0912516

SHCS M8 x 16
D0912816

Ribbed Washer \varnothing 8.4
K111010017

Angle E25 82.40.0701

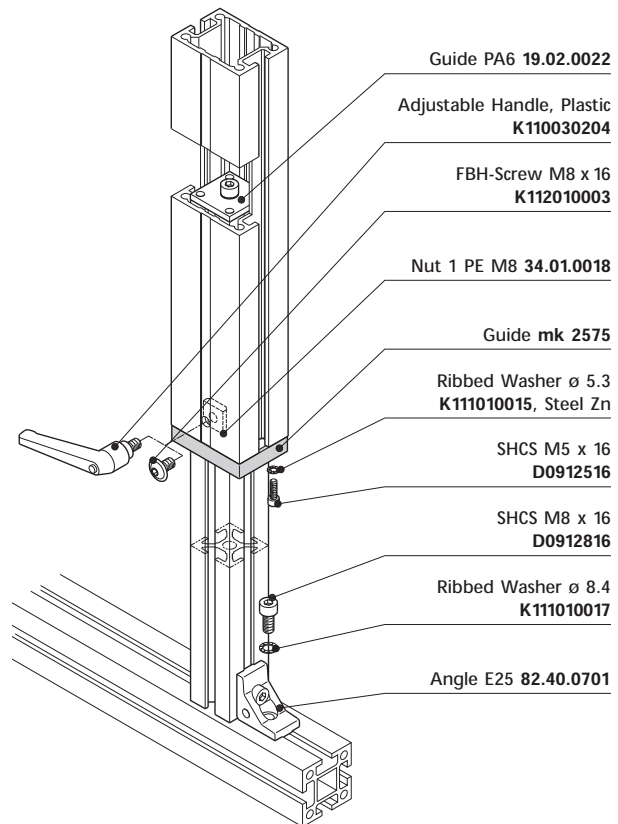

System 2000 Series 40 

Profiles for Telescoping Series 40

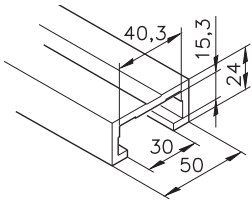

Profile mk 2040.37

1.17 kg/m
AlMgSi 0.5 F25

Stock length **54.37.5100**

Cut **54.37.***

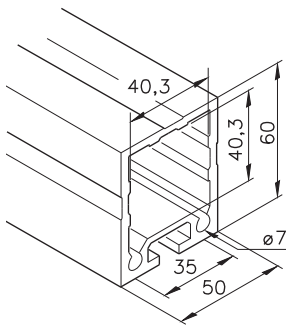

Profile mk 2040.38

2.52 kg/m
AlMgSi 0.5 F25

Stock length **54.38.5100**

Cut **54.38.***

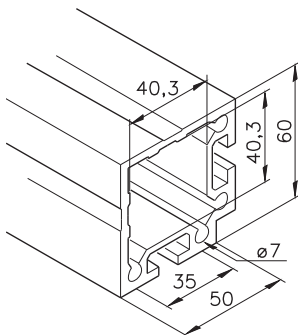

Profile mk 2040.39

3.00 kg/m
AlMgSi 0.5 F25

Stock length **54.39.5100**

Cut **54.39.***

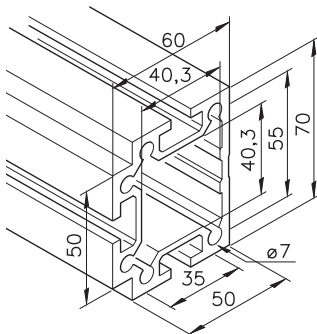

Profile mk 2040.74

3.5 kg/m
AlMgSi 0.5 F25

Stock length **54.74.5100**

Cut **54.74.***

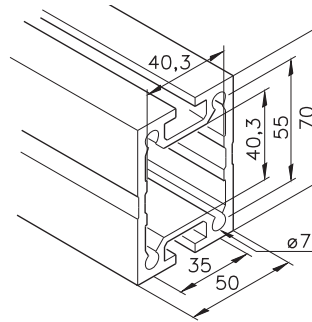

Profile mk 2040.75

3.01 kg/m
AlMgSi 0.5 F25

Stock length **54.75.5100**

Cut **54.75.***

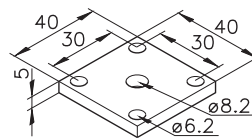

**Guide
19.02.0022**

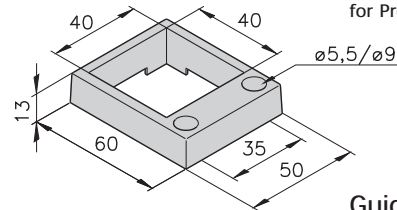

**Guide
mk 2538**
for Profile mk 2040.38

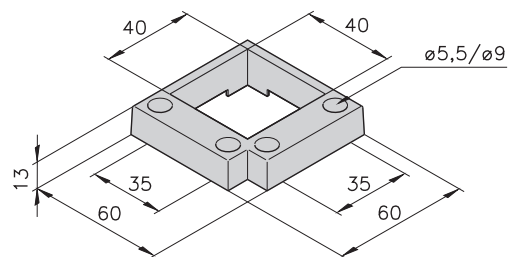

**Guide
mk 2539**
for Profile mk 2040.39

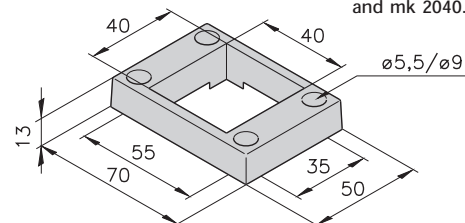

**Guide
mk 2575**
for Profile mk 2040.74
and mk 2040.75

....* Profile length in mm

Universe Profilseries



Structural Profiles

System 2000 Series 40 

Profiles for Partitions and Workstations

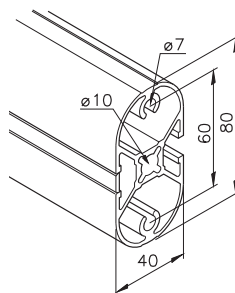

Profile mk 2040.23

2.12 kg/m

AlMgSi 0.5 F25

Stock length **54.23.5100**

Cut **54.23. ***

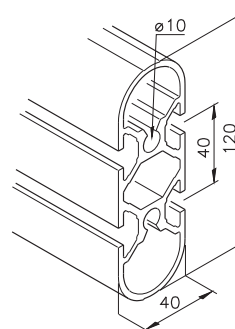

Profile mk 2040.34

3.56 kg/m

AlMgSi 0.5 F25

Stock length **54.34.5100**

Cut **54.34. ***

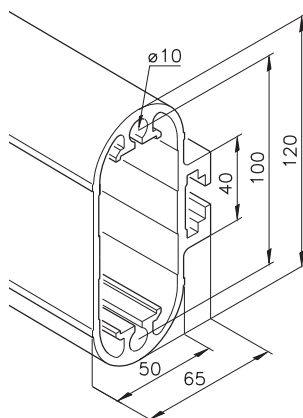

Profile mk 2040.30

4.36 kg/m

AlMgSi 0.5 F25

Stock length **54.30.5100**

Cut **54.30. ***

....* Profile length in mm



System 2000 Series 40 

Profiles for Sliding Doors

Profile for Handles

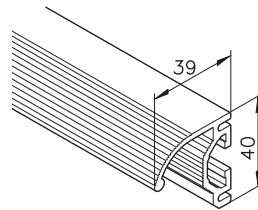

Profile mk 2244
 0.87 kg/m
 AlMgSi 0.5 F25

Stock length **52.44.5100**

Cut **52.44.***

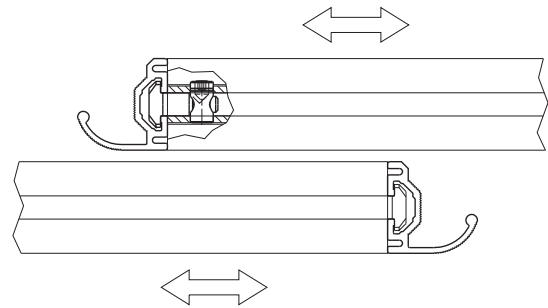

Profile for Track

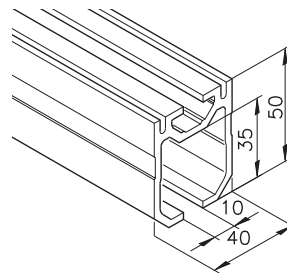

Profile mk 2245
 1.54 kg/m
 AlMgSi 0.5 F25

Stock length **52.45.5100**

Cut **52.45.***

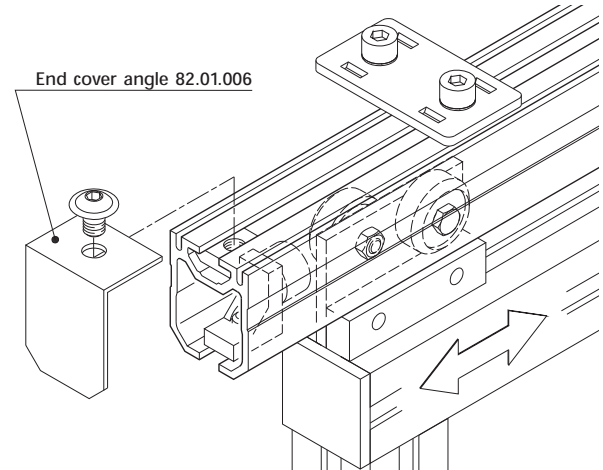

....* Profile length in mm

Structural profiles

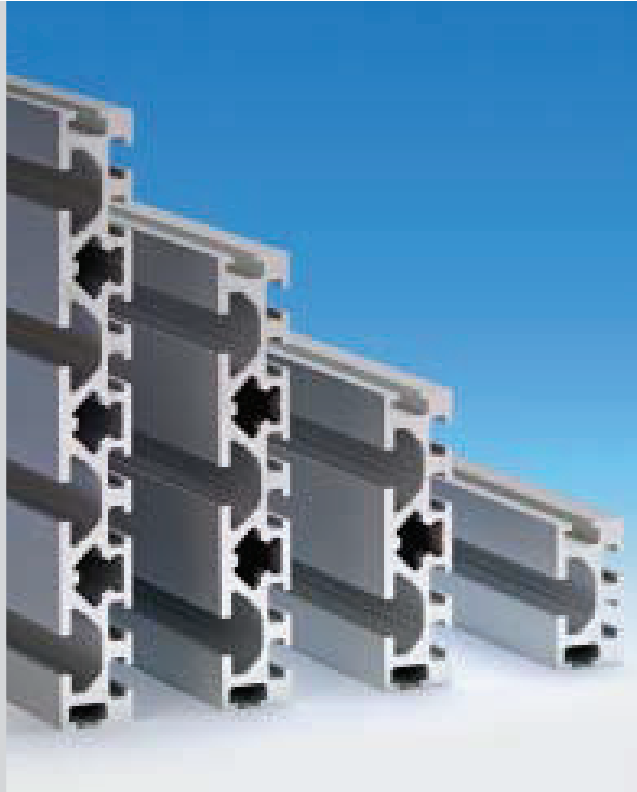

System 2000 Series 40

Adapter Profiles from series 40 to series 25

One profile side has series 40 T-slots; the other profile side has series 25 T-slots. This makes it possible to combine elements from series 25 and 40. Applications include:

- Locations within larger frames for small, series 25 access windows.
- As mounting locations for valve banks.

Threaded Insert M8
K112030008

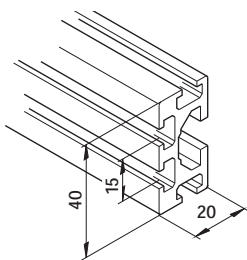
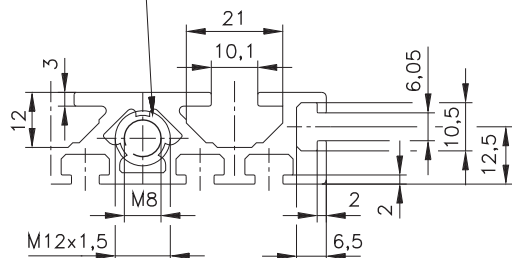

Profile mk 2025.41

1.02 kg/m
AlMgSi 0.5 F25

Stock length **25.41.5100**

Cut **25.41. ***

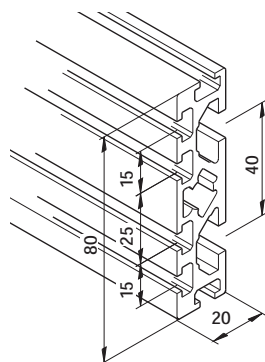

Profile mk 2025.42

1.94 kg/m
AlMgSi 0.5 F25

Stock length **25.42.5100**

Cut **25.42. ***

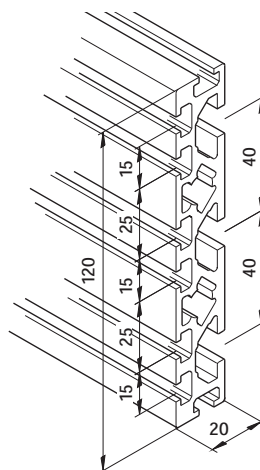

Profile mk 2025.43

2.86 kg/m
AlMgSi 0.5 F25

Stock length **25.43.5100**

Cut **25.43. ***

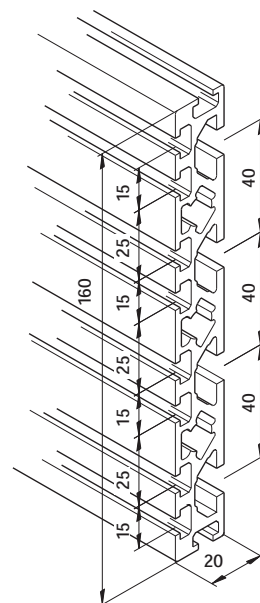

Profile mk 2025.44

3.77 kg/m
AlMgSi 0.5 F25

Stock length **25.44.5100**

Cut **25.44. ***

....* Profile length in mm

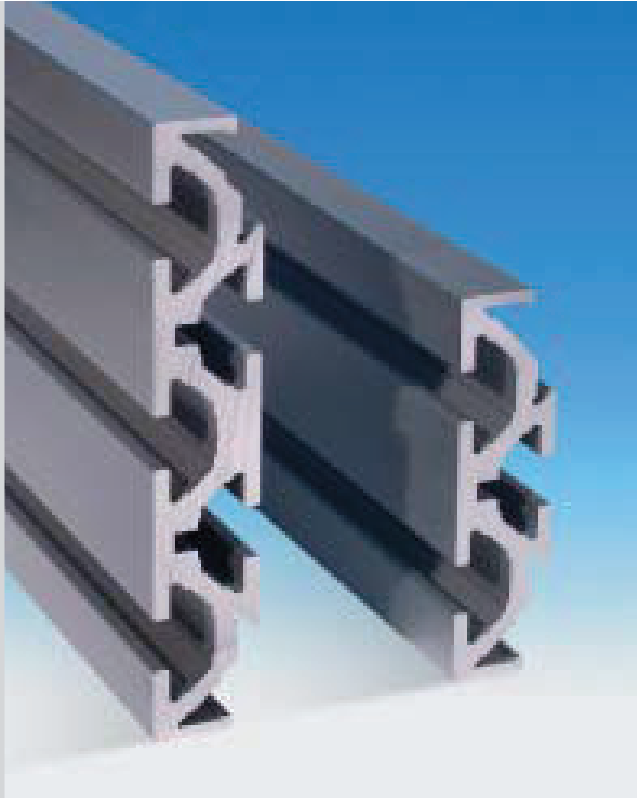

System 2000 Series 40 

Adapter Profiles from series 40 to series 40

These adapter profiles allow central transitions from profiles with even to uneven number of nuts and vice versa. A possible application is the fitting of panels with panel profiles in framework constructions of 40 mm width.

 For further information see page 191

Profile mk 2040.80, 54.80.*

Profile mk 2040.82, 54.82.*

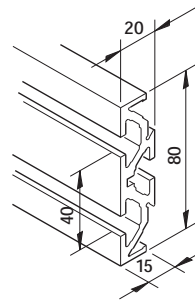
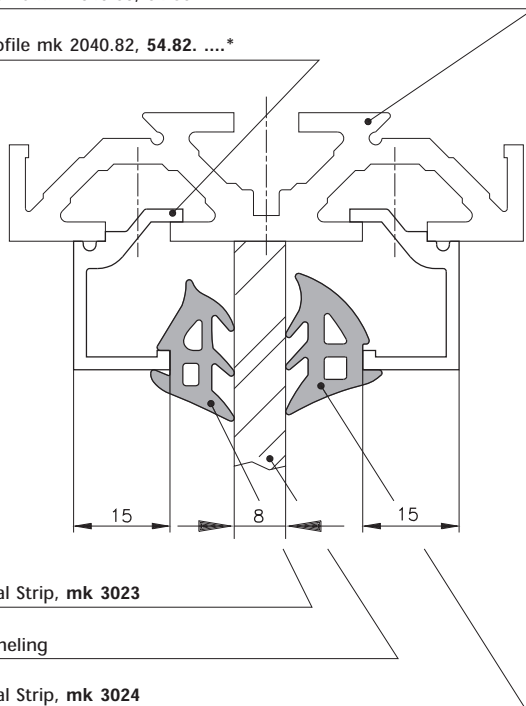

Profile mk 2040.80

1.83 kg/m
 AlMgSi 0.5 F25

Stock length **54.80.5100**

Cut **54.80.***

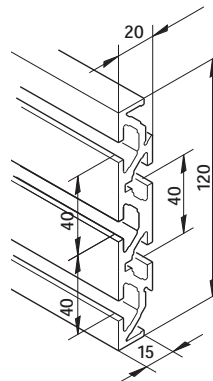

Profile mk 2040.86

2.90 kg/m
 AlMgSi 0.5 F25

Stock length **54.86.5100**

Cut **54.86.***

Structural Profiles



System 2000 Series 40 

Profile Series 40 Cover profiles

These profiles can be clipped into profile T-slots without additional mounting hardware.

Used in:

- Factory equipment
- Exhibition stand construction
- Power supply columns

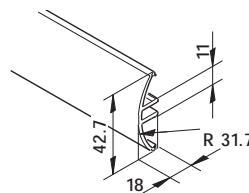
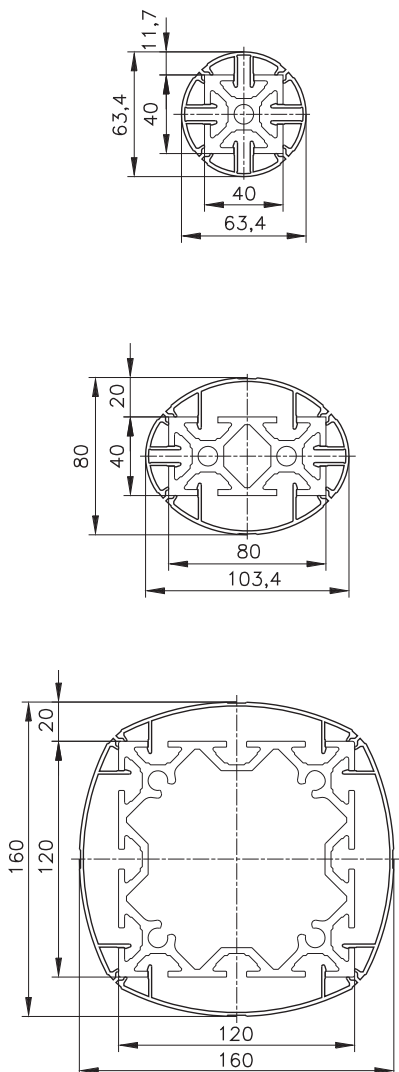

Profile mk 2040.43

0.41 kg/m
AlMgSi 0.5 F25

Stock length **54.43.5100**

Cut **54.43. ***

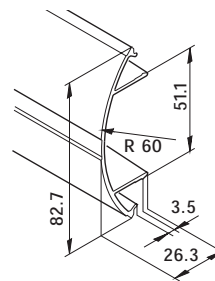

Profile mk 2040.42

0.68 kg/m
AlMgSi 0.5 F25

Stock length **54.42.5100**

Cut **54.42. ***

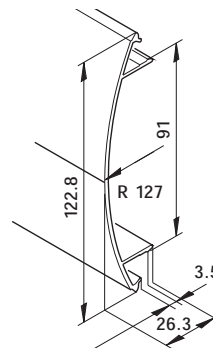

Profile mk 2040.44

0.85 kg/m
AlMgSi 0.5 F25

Stock length **54.44.5100**

Cut **54.44. ***

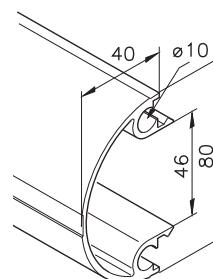

Profile mk 2040.32

1.26 kg/m
AlMgSi 0.5 F25

Stock length **54.32.5100**

Cut **54.32. ***

....* Profile length in mm



System 2000 Series 40 

Profile Series 40 Cover profiles

Profiles mk 2040.67 and mk 2040.85 are used to cover series 40 structural profiles.

Features include:

- The profiles do not have to be secured with screws.
- T-slots can be closed off so that dirt does not accumulate in them.
- The profile grooves provide slip resistance if the profiles are used on tread surfaces.
- Wireways can be quickly and easily covered.

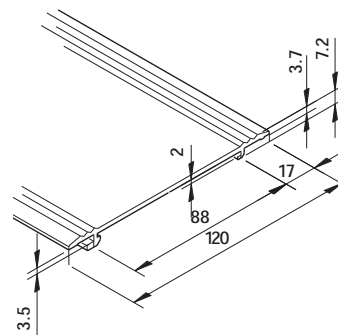
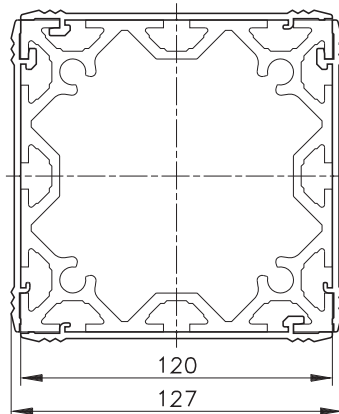

Profile mk 2040.85

0.93 kg/m

AlMgSi 0.5 F25

Stock length **54.85.5100**

Cut **54.85.***

Structural Profiles

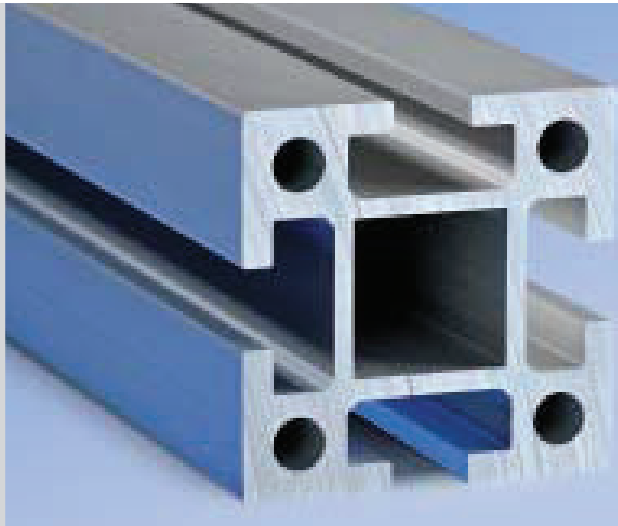

System 2000 Series 50 

Series 50 Dimensions and Threads

Series 50 is designed on a 50 x 50 mm base dimension. The 10 mm T-slots are spaced at 50 mm. Threads can be cut into the extruded holes.

 Profile services see page 74

Profile ends can be tapped directly.  P. 224

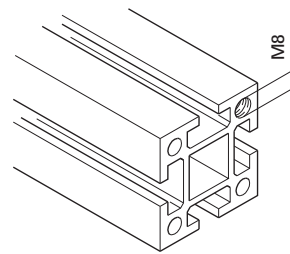

Recommended screw length = $2 \cdot d_N$

Other threads possible with inserts.  P. 81

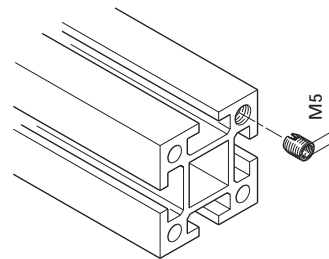

Threaded Insert M5
K112030005

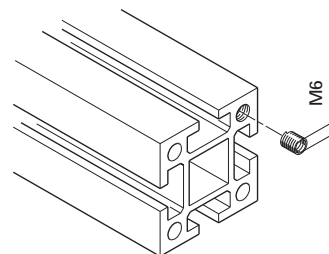

Helicoil M6
K112030106

d_N = Thread diameter

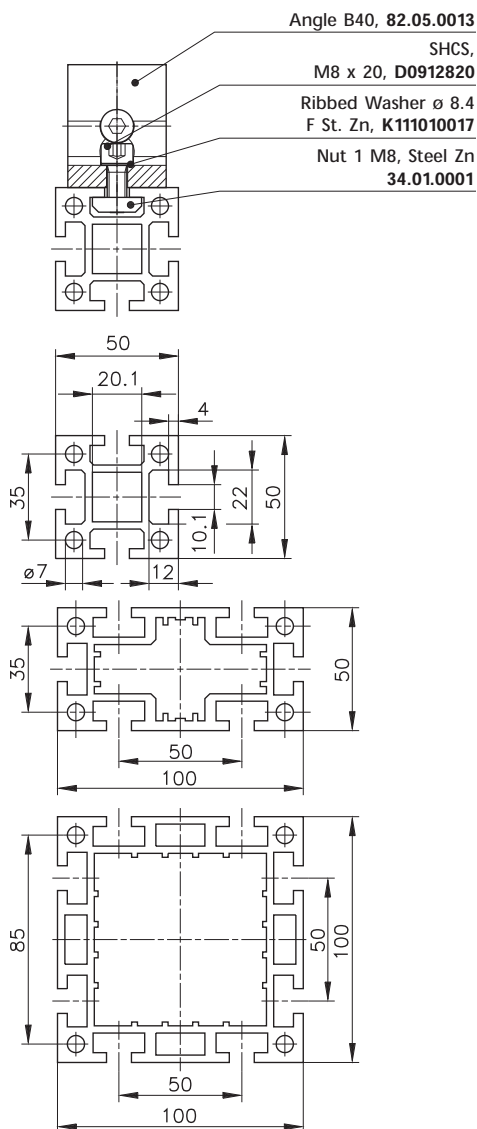

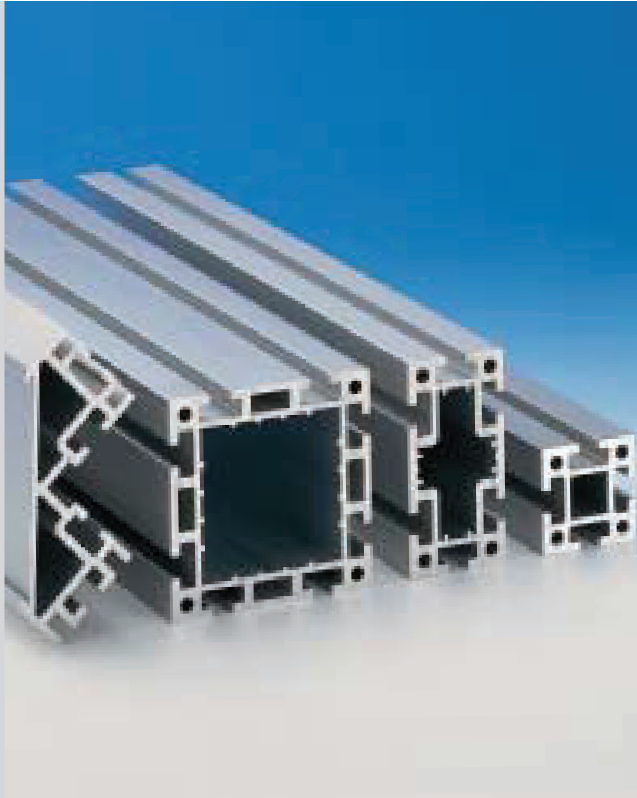

System 2000 Series 50 

Series 50

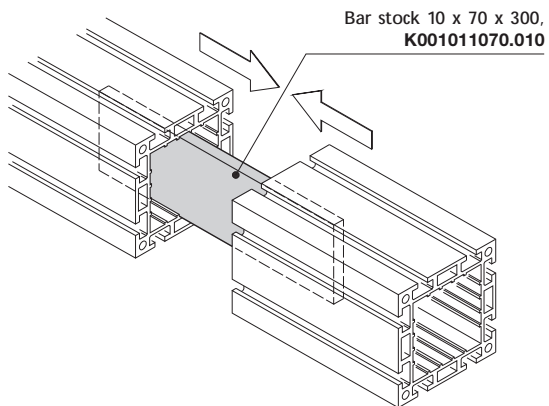
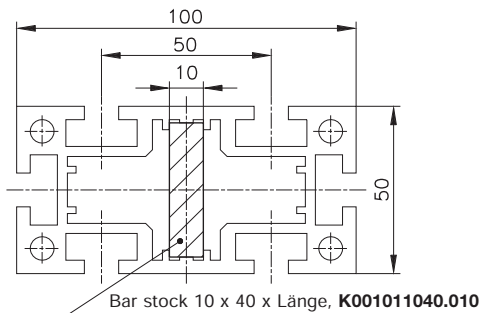

The load-bearing capacity of series 50 structural profiles can be increased by up to 30% using steel bar stock. This is then fixed, i.e. by foaming. Profile joints can also be stabilized in this way. In this case the insertion depth should be at least twice the width of the steel.

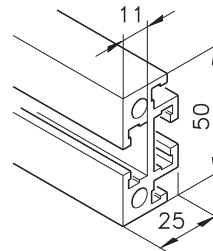

Profile mk 2001

1.49 kg/m
AlMgSi 0.7 F28

Stock length **51.01.5100**

Cut **51.01. ***

Services from page 74

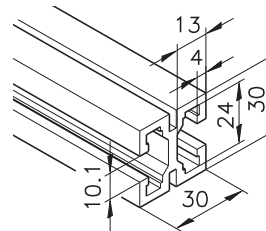

Profile mk 2030

1.06 kg/m
AlMgSi 0.7 F28

Stock length **51.30.5100**

Cut **51.30. ***

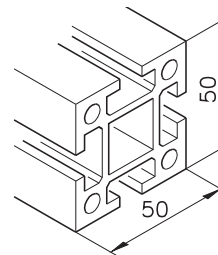

Profile mk 2000

2.85 kg/m
AlMgSi 0.7 F28

Stock length **51.00.5100**

Stock length **51.00.6100**

Cut **51.00. ***

Services from page 74

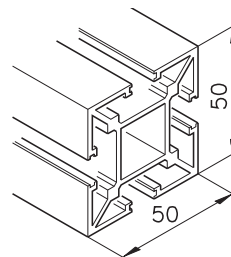

Profile mk 2002 (light)

1.75 kg/m
AlMgSi 0.5 F25

Stock length **51.02.5100**

Cut **51.02. ***

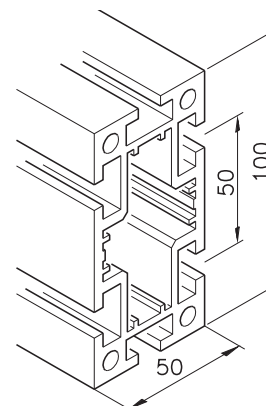

Profile mk 2004

4.87 kg/m
AlMgSi 0.7 F28

Stock length **51.04.5100**

Stock length **51.04.6100**

Cut **51.04. ***

Services from page 74

Structural Profiles

System 2000 Series 50 

Series 50

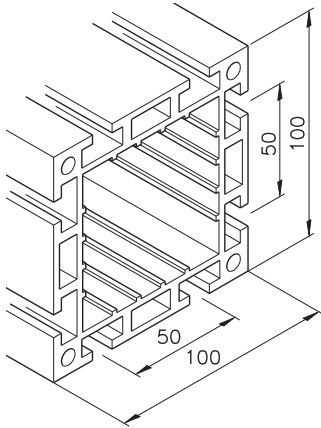

Profile mk 2005

7.00 kg/m
AlMgSi 0.7 F28

Stock length **51.05.5100**

Stock length **51.05.6100**

Cut **51.05.***

Services from page 74

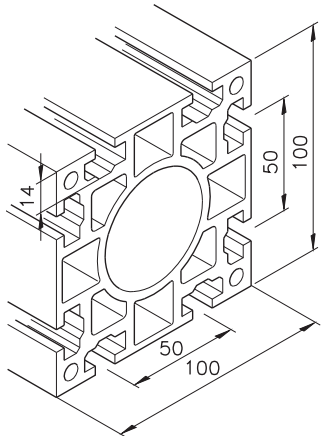

Profile mk 2011

9.70 kg/m
AlMgSi 0.7 F28

Stock length **51.11.5100**

Stock length **51.11.6100**

Cut **51.11.***

Services from page 74

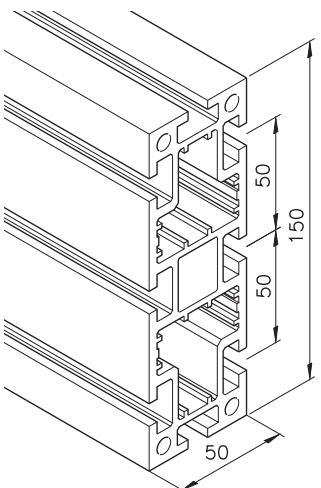

Profile mk 2006

7.00 kg/m
AlMgSi 0.7 F28

Stock length **51.06.5100**

Cut **51.06.***

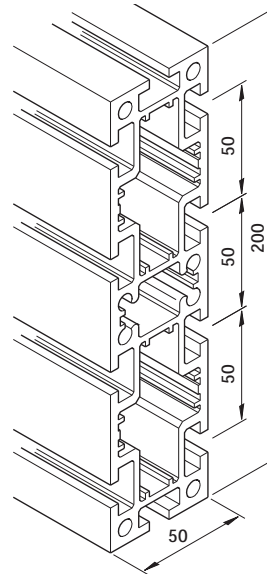

Profile mk 2008

9.09 kg/m
AlMgSi 0.7 F28

Stock length **51.08.5100**

Stock length **51.08.6100**

Cut **51.08.***

Services from page 74

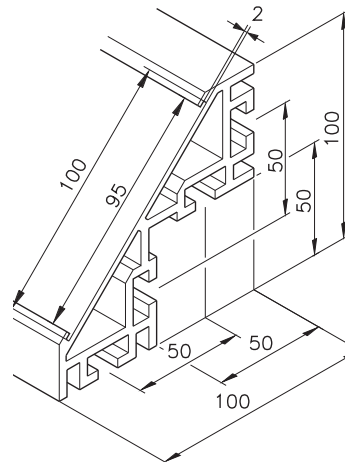

Profile mk 2072

4.62 kg/m
AlMgSi 0.7 F28

Stock length **51.72.5100**

Cut **51.72.***

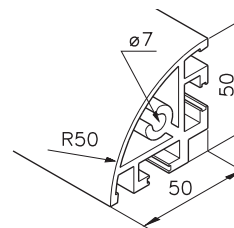

Profile mk 2003

2.00 kg/m
AlMgSi 0.5 F25

Stock length **51.03.5100**

Cut **51.03.***

Services from page 74

....* Profile length in mm



System 2000 Series 50 

Cleanroom Profiles Series 50

Profile mk 2017 has been designed to be a completely standard system profile, which is to say that it can be used with all assembly components. The T-slot can be opened, either partially or completely, with very little effort using the parting tool. Designed exclusively for use with mk profiles, very little force is required. If a partial removal of the cover is desired, we recommend placing a drilled hole at the exact location.

Drill

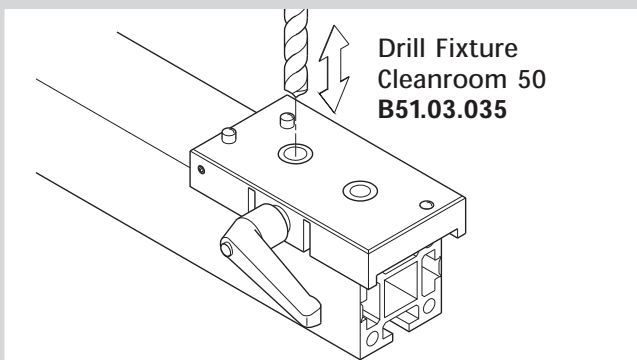

 Drill Fixtures see page 228

Part

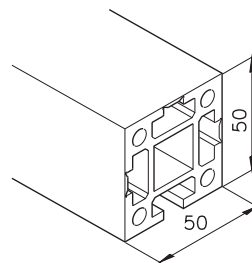
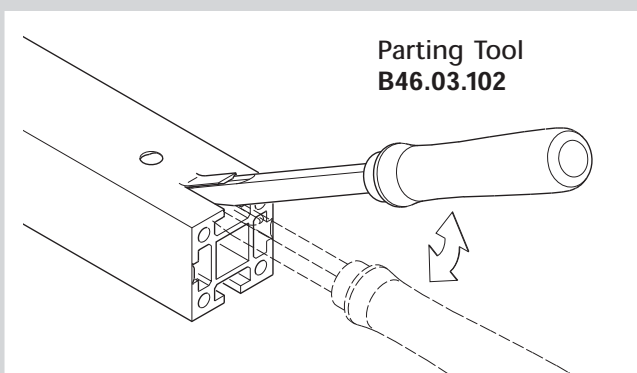

Profile mk 2017

3.03 kg/m
 AlMgSi 0.5 F25

Stock length **51.17.5100**

Cut **51.17.***

Deburr

Manual deburring can be easily carried out during the assembly process using a deburring block.

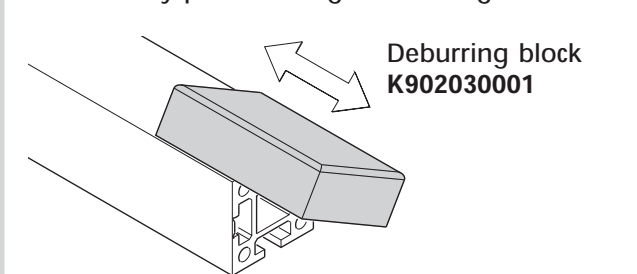

....* Profile length in mm

Structural Profiles

System 2000 Series 50 

Profiles for Telescoping Series 50

In combination with the base Profile mk 2000 (50 x 50 mm), height adjustment for workstations, conveyors and subframes is readily accomplished. These profiles are available with services to your specifications (cut, drilled, milled).

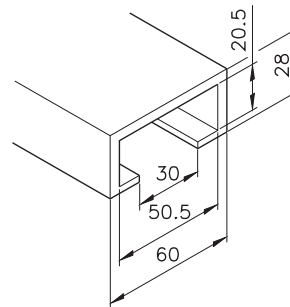
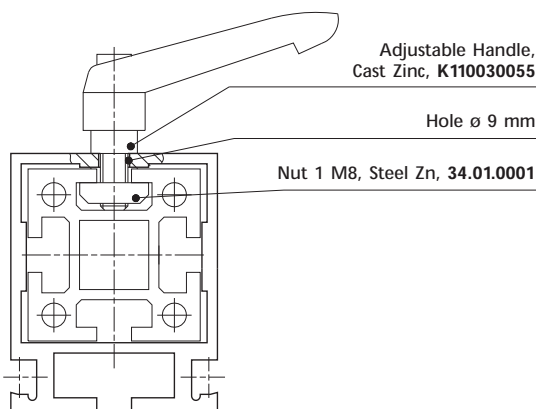
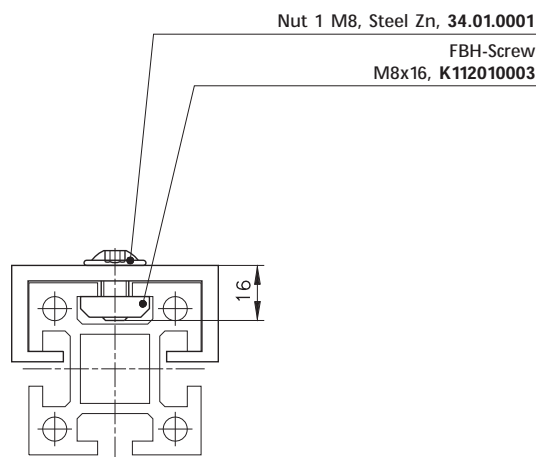

Profile mk 2033

1.50 kg/m
AlMgSi 0.7 F28

Stock length **51.33.5100**

Cut **51.33.***

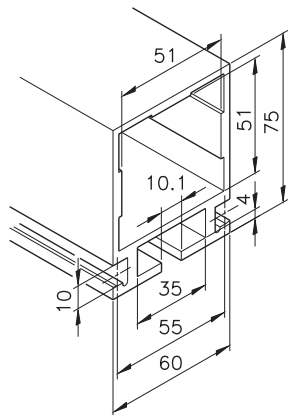

Profile mk 2031

2.85 kg/m
AlMgSi 0.7 F28

Stock length **51.31.5100**

Cut **51.31.***

If using adjustable handles, the drilled-hole diameter must be 9 mm.

....* Profile length in mm

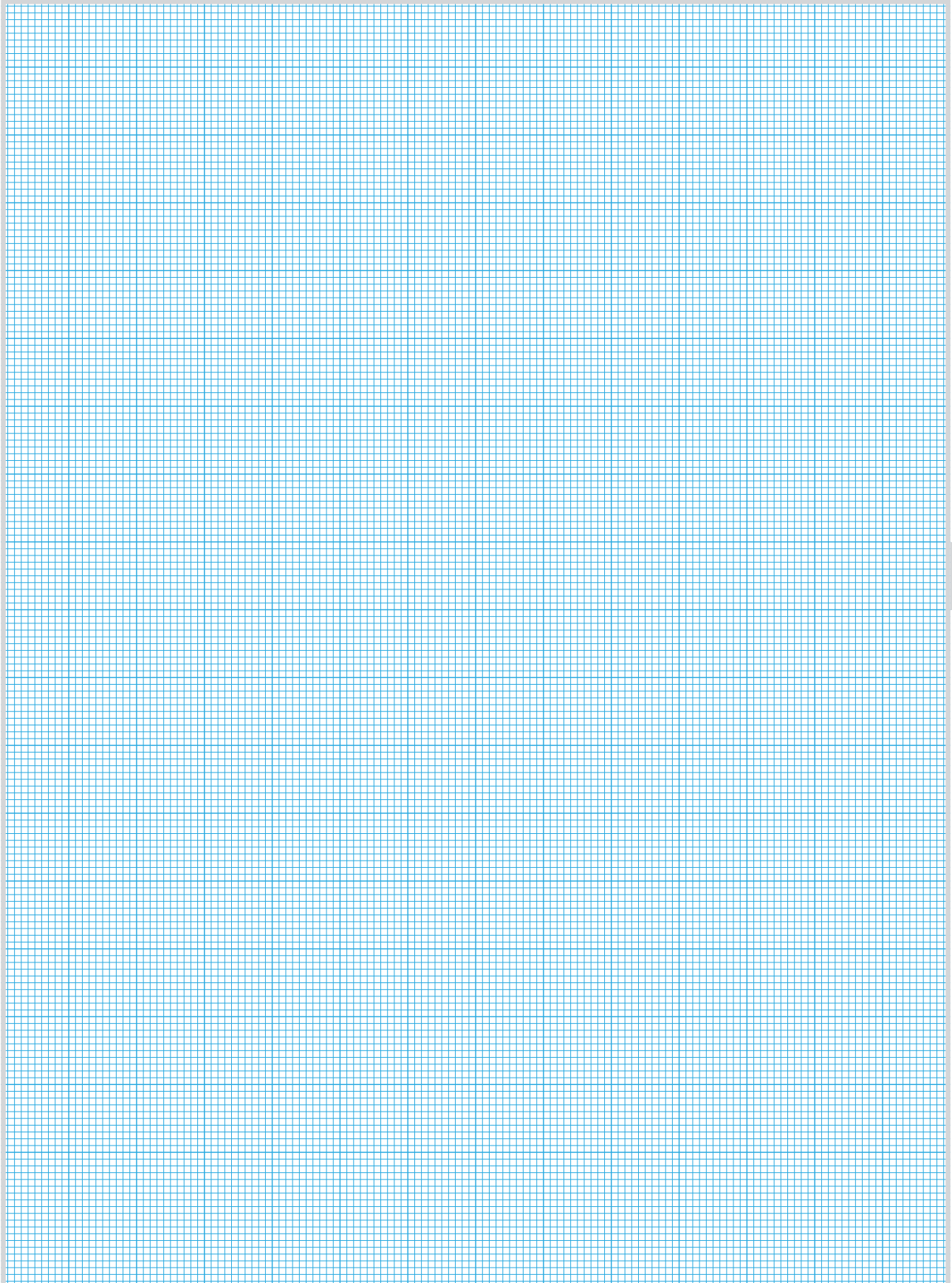

Structural Profiles

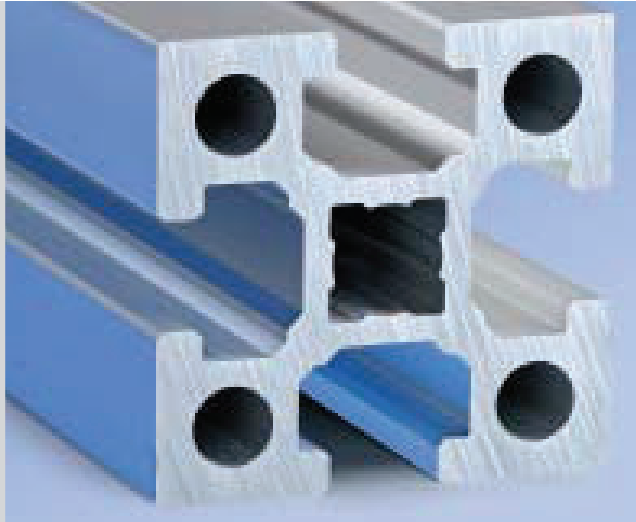

System 2000 Series 60



Series 60 Dimensions and Threads

Series 60 is designed on a 60 x 60 mm base dimension. The 14 mm T-slots are spaced at 60 mm. Threads can be cut into the extruded holes.

Profile services see page 74

Profile ends can be tapped directly.

P. 224

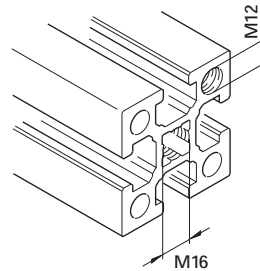
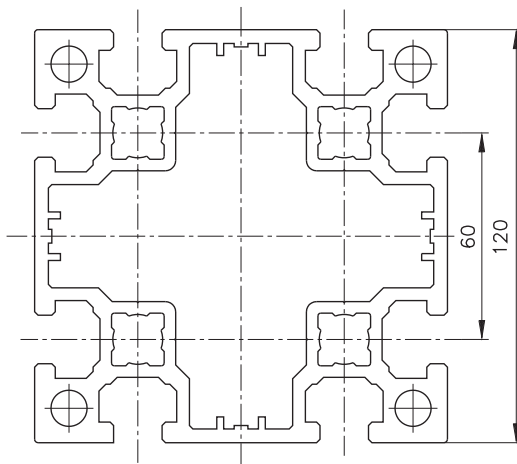
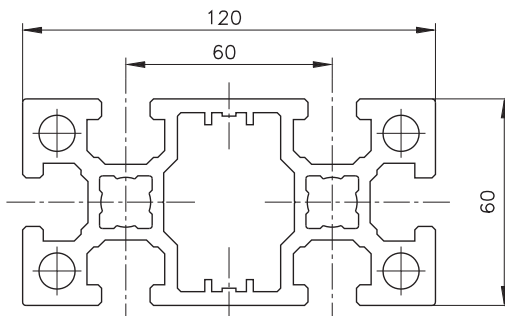
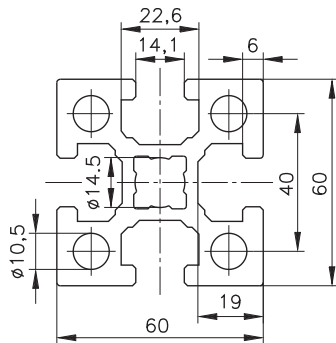

Recommended screw length = $2 \cdot d_N$

Reduced load bearing capacity if tapping M16 directly.

Other threads possible with inserts.

P. 81

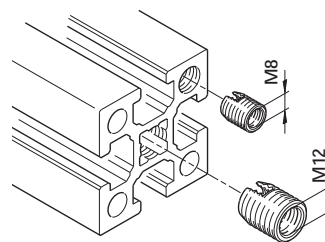

Threaded Insert M8
K112030008

Threaded Insert M12
K112030010

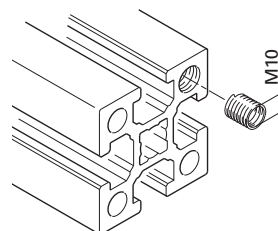

Helicoil M10
K112030110

d_N = Thread diameter



System 2000 Series 60

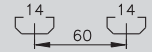

Series 60

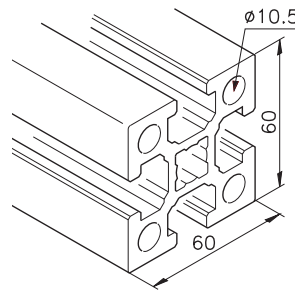

Profile mk 2060.01

4.31 kg/m
AlMgSi 0.7 F28

Stock length **60.01.5100**

Cut **60.01. ***

Services from page 74

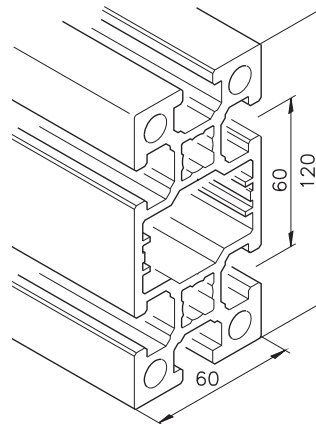
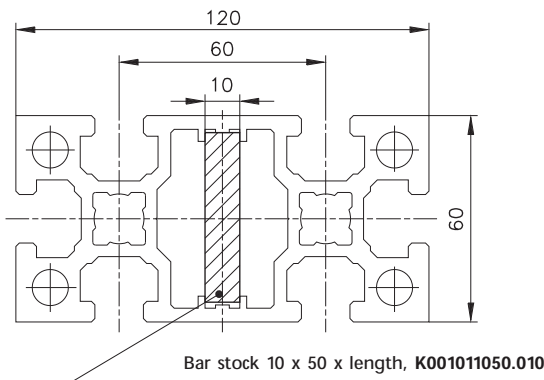

Profile mk 2060.02

6.95 kg/m
AlMgSi 0.7 F28

Stock length **60.02.5100**

Cut **60.02. ***

Services from page 74

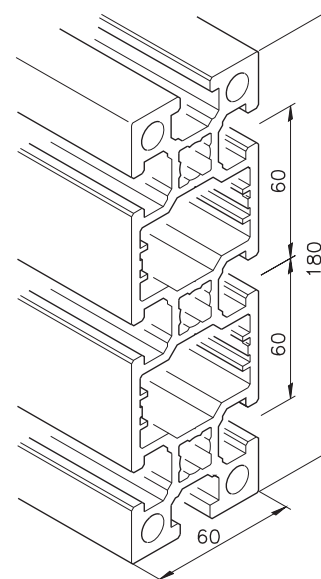
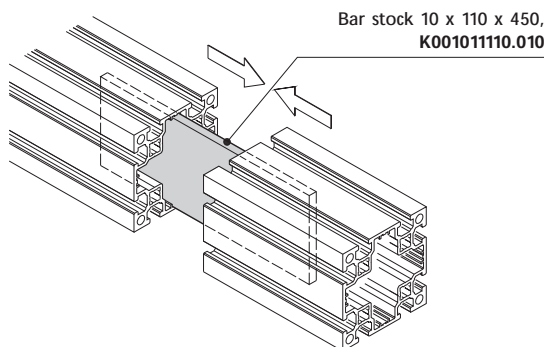

Profile mk 2060.03

9.57 kg/m
AlMgSi 0.7 F28

Stock length **60.03.5100**

Cut **60.03. ***

Services from page 74

The load-bearing capacity of series 60 structural profiles can be increased by up to 34% using steel bar stock. This is then fixed, i.e. by foaming. Profile joints can also be stabilized in this way. In this case the insertion depth should be at least twice the width of the steel.

Structural Profiles

System 2000 Series 60

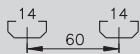

Series 60

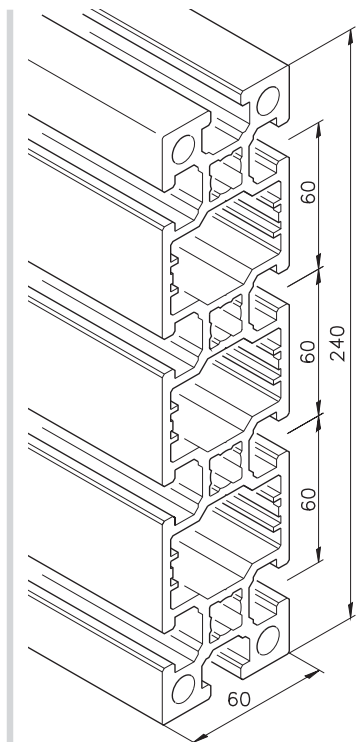

Profile mk 2060.04

12.20 kg/m
AlMgSi 0.7 F28

Stock length **60.04.5100**

Cut **60.04. ***

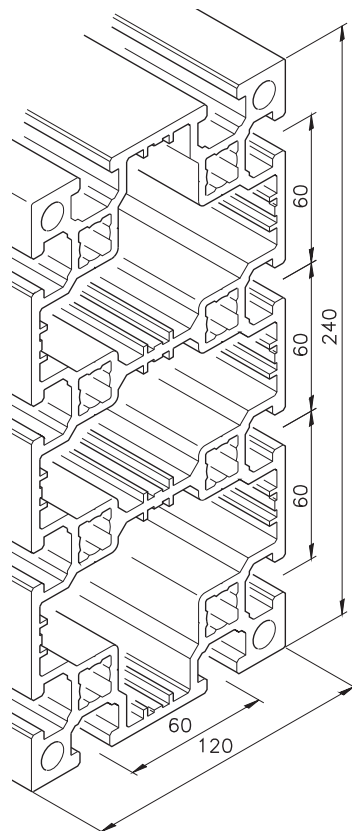

Profile mk 2060.07

18.10 kg/m
AlMgSi 0.5 F25

Stock length **60.07.5100**

Cut **60.07. ***

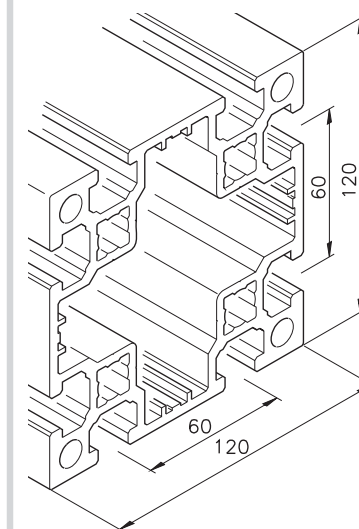

Profile mk 2060.05

10.30 kg/m
AlMgSi 0.7 F28

Stock length **60.05.5100**

Cut **60.05. ***

Services **from page 74**

....* Profile length in mm

Structural Profiles

Profiles for Sliding Windows

Profiles mk 2240 and mk 2241 have multiple uses in Series 40 and 50 applications. To install these profiles, countersunk holes must be placed at appx. 300 mm intervals.

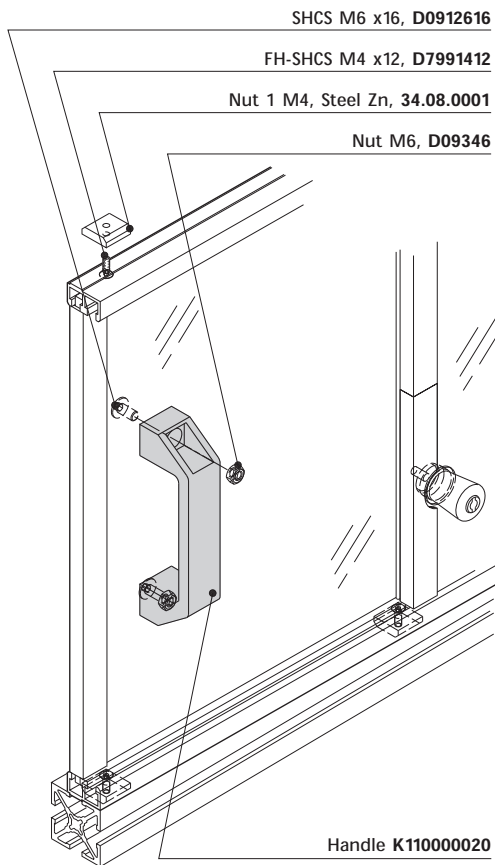

The countersunk hole in the profiles must be made using a D335C 8.3 mm countersink.

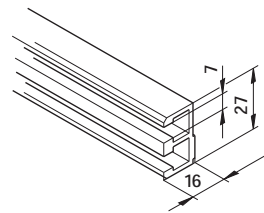

Profile mk 2240

0.47 kg/m
 AlMgSi 0.5 F25

Stock length **52.40.5100**

Cut **52.40.***

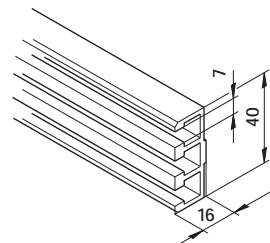

Profile mk 2241

0.67 kg/m
 AlMgSi 0.5 F25

Stock length **52.41.5100**

Cut **52.41.***

Structural Profiles

Structural Profiles

Profiles for Sheets and Paneling



For paneling such as Polycarbonate or Alucobond.

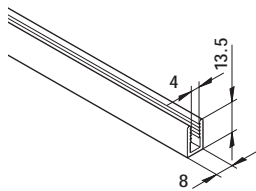

Profile mk 2206

0.14 kg/m
AlMgSi 0.5 F25

Stock length **52.06.6000**

Cut **52.06.***

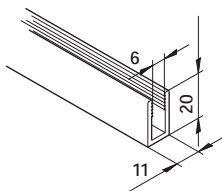

Profile mk 2207

0.27 kg/m
AlMgSi 0.5 F25

Stock length **52.07.6000**

Cut **52.07.***

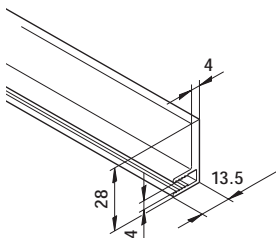

Profile mk 2203

0.35 kg/m
AlMgSi 0.5 F25

Stock length **52.03.6000**

Cut **52.03.***

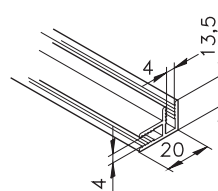

Profile mk 2210

0.25 kg/m
AlMgSi 0.5 F25

Stock length **52.10.6000**

Cut **52.10.***

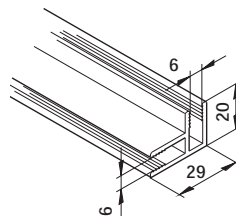

Profile mk 2211

0.47 kg/m
AlMgSi 0.5 F25

Stock length **52.11.6000**

Cut **52.11.***

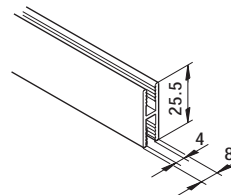

Profile mk 2214

0.25 kg/m
AlMgSi 0.5 F25

Stock length **52.14.6000**

Cut **52.14.***

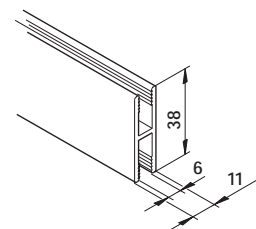

Profile mk 2215

0.47 kg/m
AlMgSi 0.5 F25

Stock length **52.15.6000**

Cut **52.15.***

....* Profile length in mm

Structural Profiles

Profiles for
 Door Frames



With profiles mk 2040.88 and mk 2040.25 door stops can be placed into partitions or guarding systems for two common door styles. The profiles can be placed around the entire perimeter of the door, and the seal strips serve to both dampen and seal the door upon closing. Profile mk 2040.25 is also used for doors manufactured using Series 40 profiles.

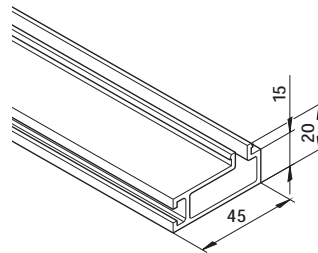
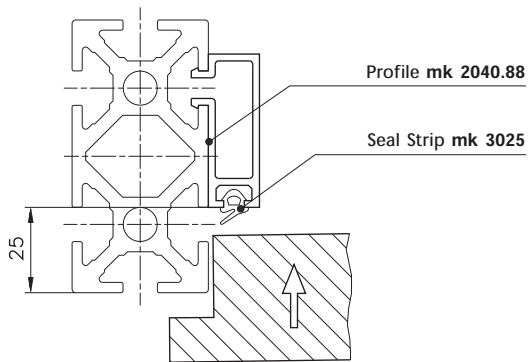

Profile mk 2040.88

0.67 kg/m
 AlMgSi 0.5 F25

Stock length **54.88.5100**

Cut **54.88. ***

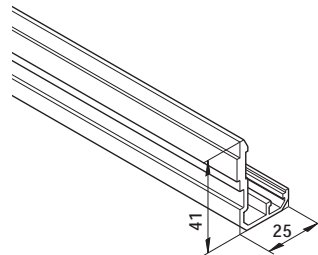
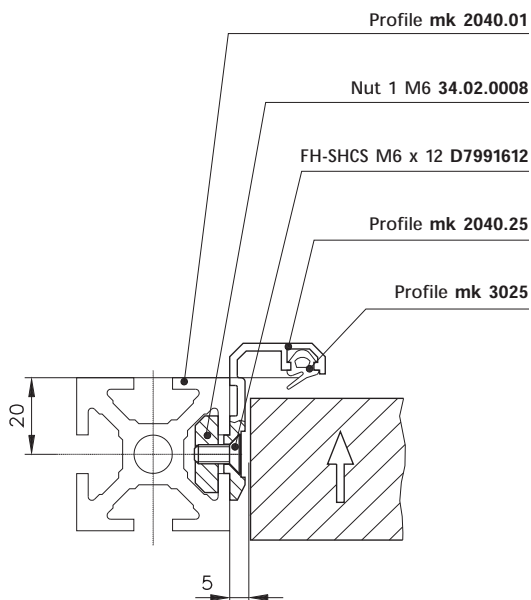

Profile mk 2040.25

0.50 kg/m
 AlMgSi 0.5 F25

Stock length **54.25.5100**

Cut **54.25. ***

....* Profile length in mm

Structural Profiles

Structural Profiles

Profiles for Floors and Steps

Special profiles for the manufacture of steps, machine platforms and mezzanines.

 See the Factory Equipment catalog for more information

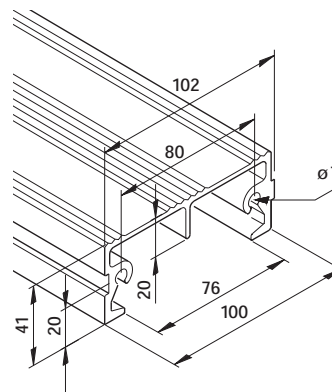

Profile mk 2040.68

2.37 kg/m
AlMgSi 0.5 F25

Stock length **54.68.6100**

Cut **54.68.***

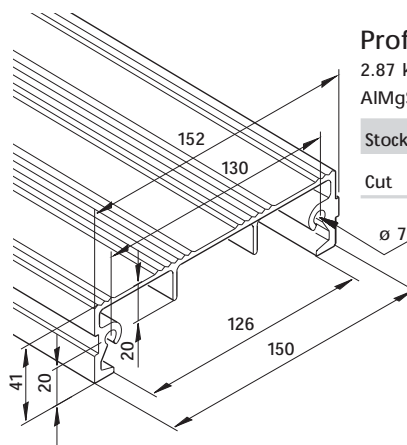

Profile mk 2040.69

2.87 kg/m
AlMgSi 0.5 F25

Stock length **54.69.6100**

Cut **54.69.***

....* Profile length in mm

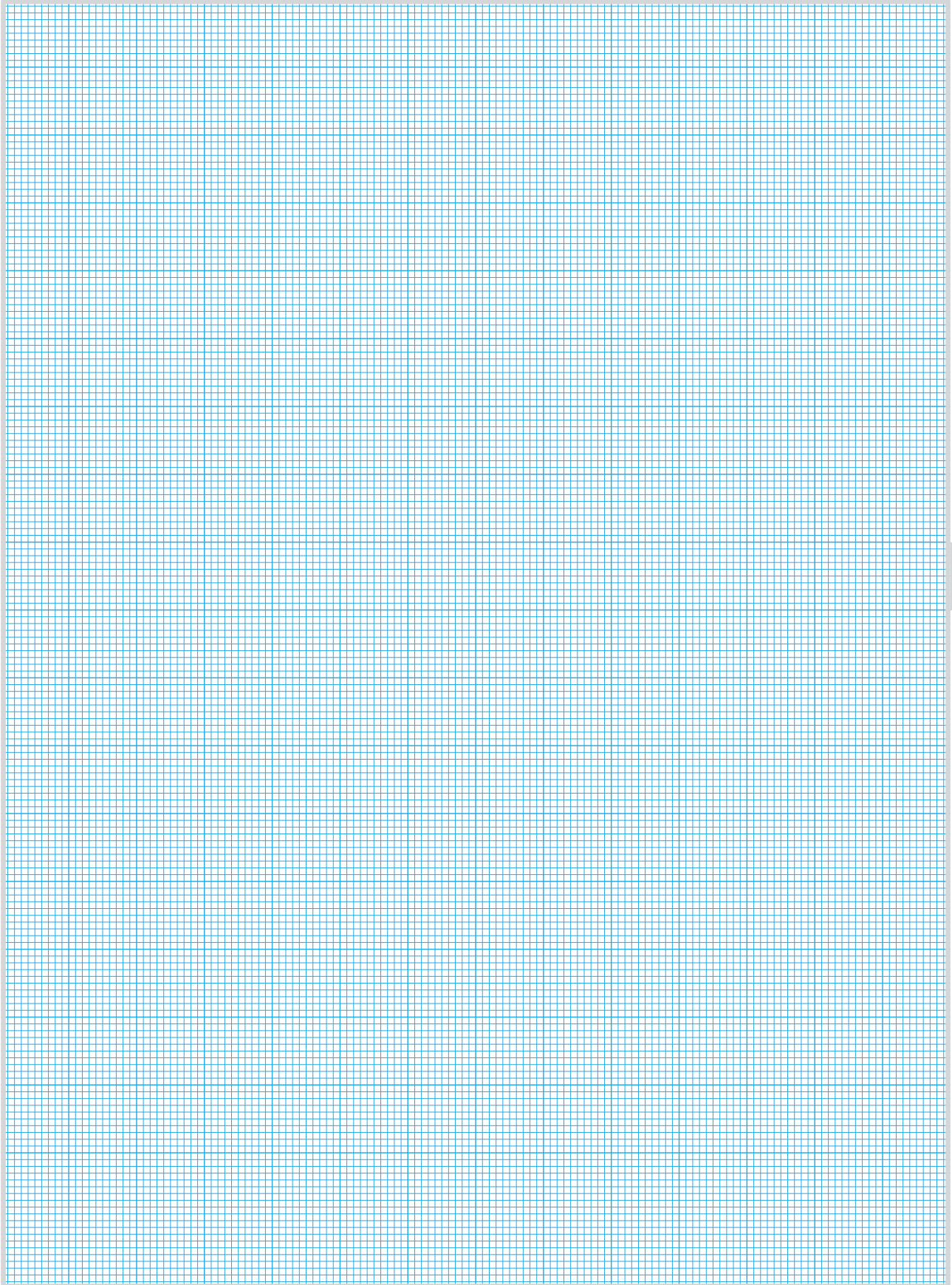

Structural Profiles

Foamed Profiles

A technological advantage unto itself, profile supports using this foam process create beams with enormous stability. They are heavily used as columns or supporting beams for mezzanines and machine frames. Foamed profiles are normally available in lengths of up to 5000 mm. On request, longer lengths may be possible.

Basically, this process is available to all profiles of series 40, 50 and 60. They are manufactured to customer specifications. Once foamed, the profiles can no longer be disassembled, and can also be used where dynamic loads are present.

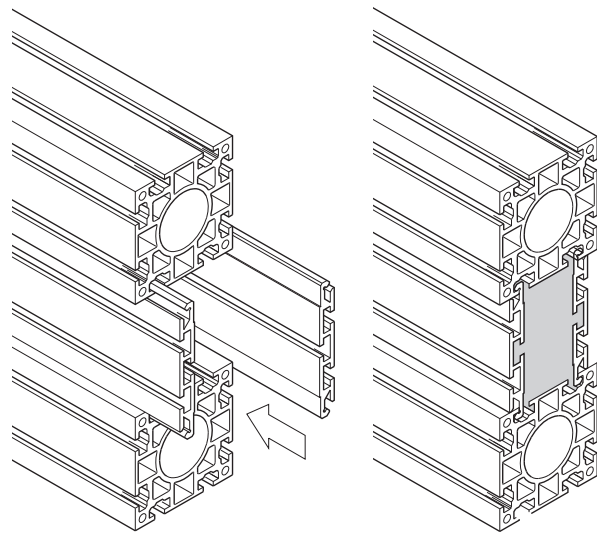

The 300 x 100 mm foamed profile illustrated with mk 2011 and mk 2067 profiles has a deflection properties comparable to that of a steel I beam IPE 220 with 220 x 110 mm.



Any 2 of the following 8 profiles ...

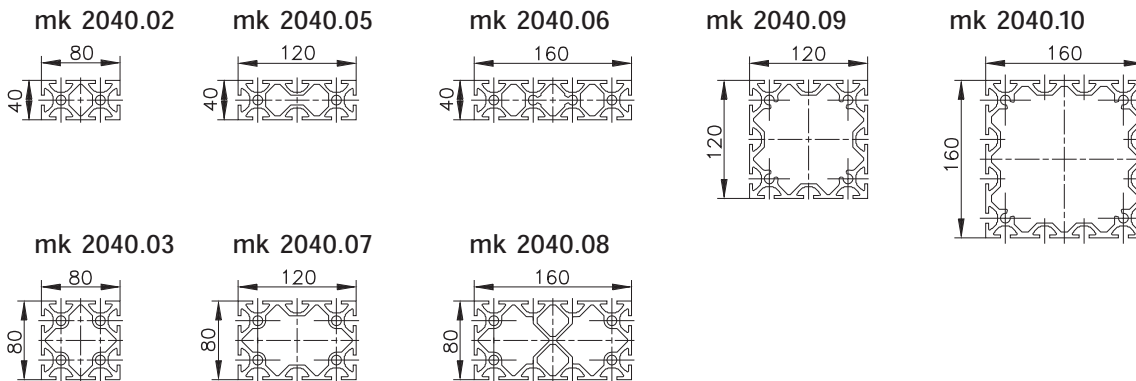

... can be combined with a pair of the following connection profiles ...

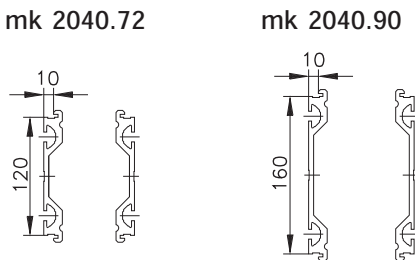

... to create in excess of 270 different foamed profiles.

Examples of frequently used foamed profile configurations

B54.90.002

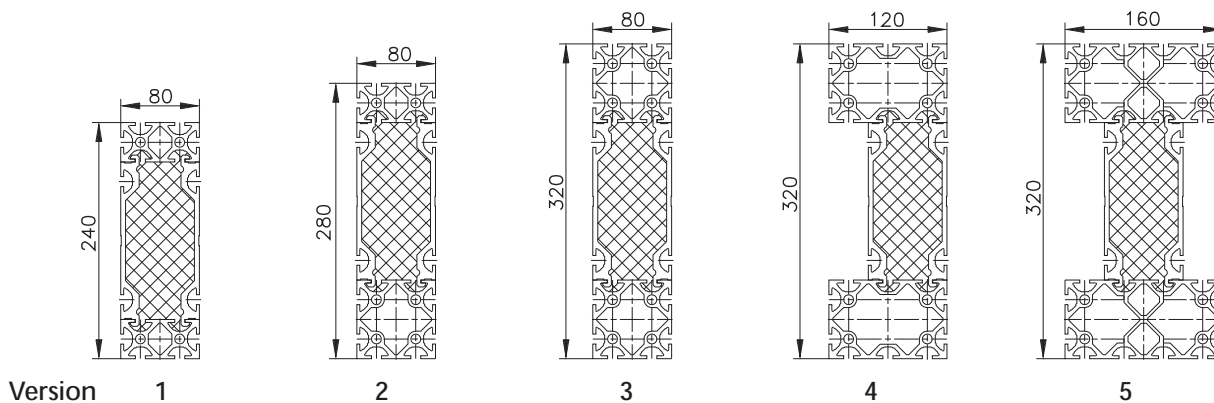

System 2000 Series 50

Any 2 of the following 4 profiles ...

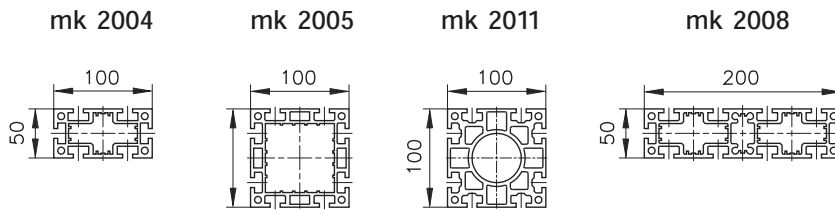

... can be combined with a pair of the following connection profiles ...

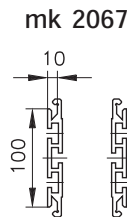

... to create in excess of 30 different foamed profiles.

Examples of frequently used foamed profile configurations:

B51.67.002

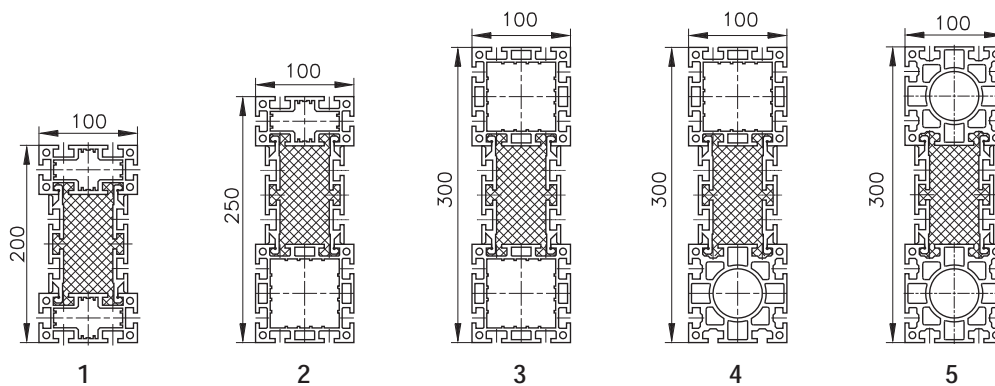

Any 2 of the following 5 profiles ...

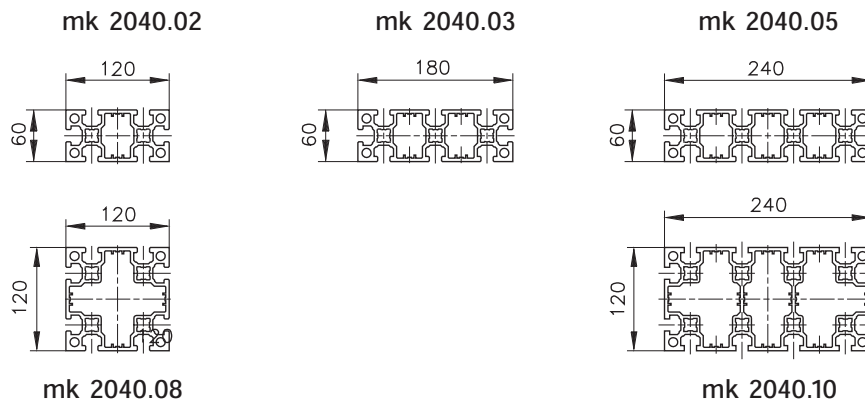

... can be combined with a pair of the following connection profiles ...

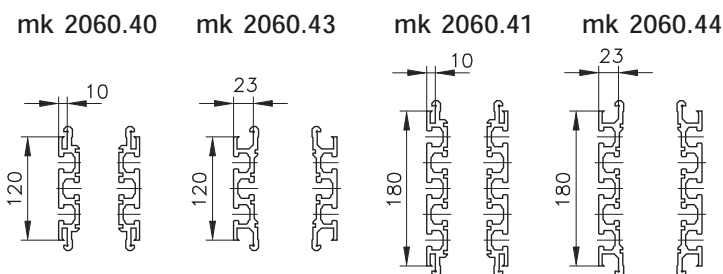

... to create in excess of 140 different foamed profiles.

Examples of frequently used foamed profile configurations:

B60.41.002

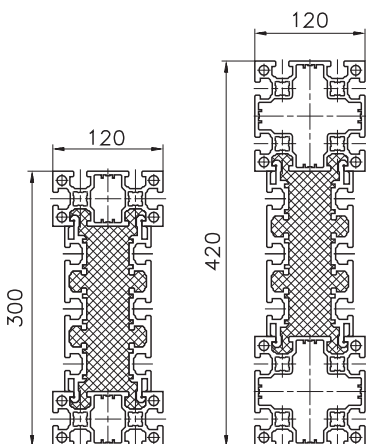

Version 1

2

B60.41.003

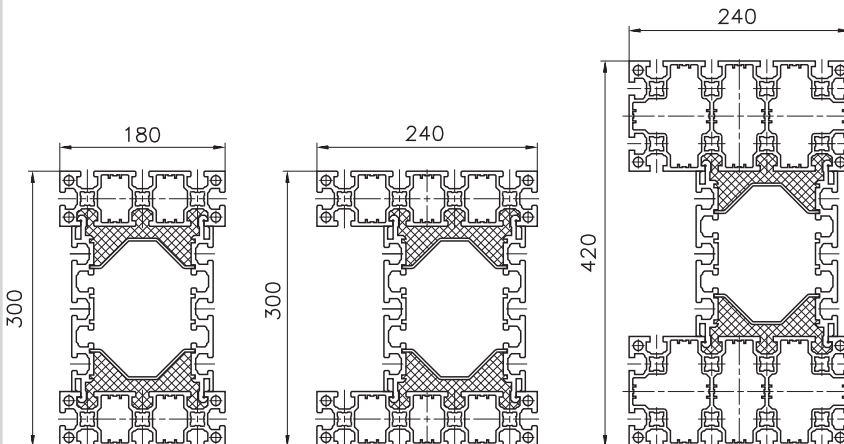

Version 1

4

5

Structural Profiles

Profile Services





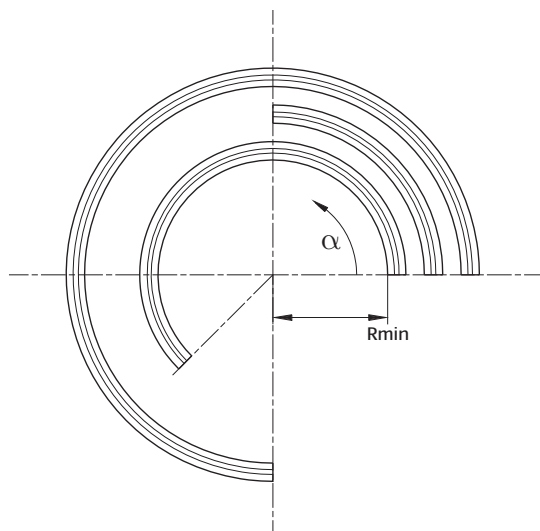

Curved Profiles





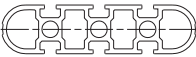

mk offers many profiles in a curved format. Curves with all angles can be produced individually, especially for various conveyor systems, turntables, etc. The minimum radii shown below apply to all applications such as curves, bends, rings or ring elements. Please note the horizontal bending axis. This means that only the narrow profile side can be curved.

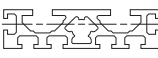
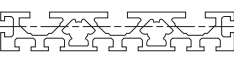

Order example

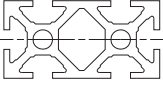
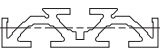
| | |
|---------------------|---------------------|
| Profile | mk 2040.01 |
| Ident-Nr. | 54.01. ...* |
| Inner radius | R = mm |
| Angle | α = mm |

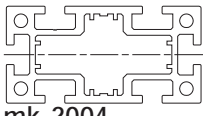
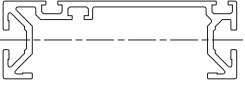
| Profile | Dimensions | R min |
|--|-------------|--------|
|  mk 2025.01 | 25 x 25 mm | 250 mm |
|  mk 2025.02 | 25 x 50 mm | 250 mm |
|  mk 2025.03 | 25 x 100 mm | 250 mm |
|  mk 2025.04 | 25 x 150 mm | 250 mm |
|  mk 2025.22 | 25 x 100 mm | 275 mm |
|  mk 2025.41 | 20 x 40 mm | 250 mm |
|  mk 2025.42 | 20 x 80 mm | 250 mm |
|  mk 2025.43 | 20 x 120 mm | 250 mm |

| <i>Profile</i> | <i>Dimensions</i> | <i>R min</i> | <i>Profile</i> | <i>Dimensions</i> | <i>R min</i> |
|---|-------------------|--------------|---|-------------------|--------------|
|  | 20 x 160 mm | 250 mm |  | 12 x 20 mm | 150 mm |
| mk 2025.44 | 20 x 160 mm | 250 mm | mk 2239 | 12 x 20 mm | 150 mm |
|  | 40 x 40 mm | 600 mm | | | |
| mk 2040.01 | 40 x 40 mm | 600 mm | | | |
|  | 40 x 80 mm | 600 mm | | | |
| mk 2040.02 | 40 x 80 mm | 600 mm | | | |
|  | 20 x 80 mm | 250 mm | | | |
| mk 2040.80 | 20 x 80 mm | 250 mm | | | |
|  | 20 x 120 mm | 250 mm | | | |
| mk 2040.86 | 20 x 120 mm | 250 mm | | | |
|  | 25 x 50 mm | 400 mm | | | |
| mk 2001 | 25 x 50 mm | 400 mm | | | |
|  | 50 x 50 mm | 1200 mm | | | |
| mk 2000 | 50 x 50 mm | 1200 mm | | | |
|  | 50 x 100 mm | 1200 mm | | | |
| mk 2004 | 50 x 100 mm | 1200 mm | | | |
|  | 25 x 100 mm | 550 mm | | | |
| mk 2066 | 25 x 100 mm | 550 mm | | | |
|  | 40 x 120 mm | 800 mm | | | |
| mk 2040.85 | 40 x 120 mm | 800 mm | | | |
|  | 15 x 30 mm | 150 mm | | | |
| mk 2238 | 15 x 30 mm | 150 mm | | | |

Structural Profiles



Profile Services

End Services

We provide a large variety of profile end services including cutting, milling, drilling, tapping and placement of threaded inserts. The items listed in the following section are just a selection of the more common services. Individual products made according to design drawings are available on request.

When requesting finishing of profiles to be used with tension plugs, please specify the hole position for the tension plug in mk 2025.02, mk 2040.02, mk 2040.03, mk 2040.41, mk 2040.45 and mk 2040.52 profiles.

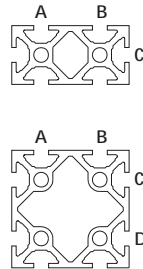

For angled cuts, please indicate the following:

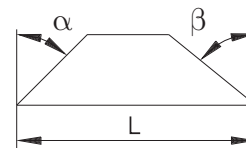

Key End Services









| | | | |
|--------------------|--|--|---|
| Faced | | | |
| Angle Cut | | | |
| Drill access hole | | | BA BB for Tension Plug 25 and 40 BF BG for Tension Plug 50 |
| Drill through hole | | | BV BW for Tension Plug 40/1 |
| Tap | | | |
| 2x Tap | | | |
| Threaded Insert | | | |
| Helicoil | | | |

Profile Services







End Services

Series 25



Profile mk 2025.01

| Services | Details |
|--|-----------------------------|
| α and β  | α, β 2501AF ...* |
| \emptyset 5.8  | 2501BA ...* |
| \emptyset 5.8  | 2501BB ...* |
| M10  | 2501AA ...* |
| M10  | 2501AB ...* |
| 4x M5  | 2501AD ...* |
| M6  | B25.01.002 ...* |
| M8  | B25.01.011 ...* |



Profile mk 2025.02

| Services | Details |
|--|-----------------------------|
| α and β  | α, β 2502AF ...* |
| \emptyset 5.8  | Location 2502BA ...* |
| \emptyset 5.8  | Location 2502BB ...* |
| M10  | 2502AC ...* |
| M10  | 2502AD ...* |
| M6  | B25.02.002 ...* |
| M8  | B25.02.011 ...* |

Profile mk 2025.05



| Services | Details |
|--|-----------------------------|
| α and β  | α, β 2505AF ...* |
| 4x M6  | B25.05.002 ...* |

Profile mk 2025.31



| Services | Details |
|---|----------------------|
| \emptyset 5.8  | Location 2531BB ...* |
| M6  | B25.31.002 ...* |

Series 25



Profile mk 2025.35

| Services | Details |
|--|-----------------|
| \emptyset 5.8  | 2535BB ...* |
| M6  | B25.35.002 ...* |



Profile mk 2025.38

| Services | Details |
|--|-----------------|
| \emptyset 5.8  | 2538BB ...* |
| M6  | B25.38.002 ...* |



Profile mk 2025.37

| Services | Details |
|--|-----------------|
| \emptyset 5.8  | 2537BB ...* |
| M6  | B25.37.002 ...* |



Profile mk 2025.32

| Services | Details |
|--|----------------------|
| \emptyset 5.8  | Location 2532BB ...* |
| M6  | B25.32.002 ...* |

Profile mk 2025.36

| Services | Details |
|--|----------------------|
| \emptyset 5.8  | Location 2536BB ...* |
| M6  | B25.36.002 ...* |

Profile mk 2025.39





































| Services | Details |
|--|-----------------|
| \emptyset 5.8  | 2539BB ...* |
| M6  | B25.39.002 ...* |

...* Profile length in mm

Structural Profiles

Profile Services

End Services







| Series 25 | | Series 40 | |
|---|------------------------|---|------------------------------------|
| Profile mk 2025.20  | | Profile mk 2040.31  | |
| Services | Details | Services | Details |
| M10  | 2520AB ...* | α and β  | α, β 5431AF ...* |
| M6  | B25.20.002 ...* | \emptyset 10  | 5431BV ...* |
| M8  | B25.20.011 ...* | \emptyset 10  | 5431BW ...* |
| Profile mk 2025.21  | | Profile mk 2040.40  | |
| Services | Details | Services | Details |
| M10  | 2521AB ...* |  | 5440AI ...* |
| M6  | B25.21.002 ...* | α and β  | α, β 5440AC ...* |
| M8  | B25.21.011 ...* | \emptyset 10  | 5440BA ...* |
| Profile mk 2025.42  | | \emptyset 10  | 5440BB ...* |
| Services | Details | \emptyset 10  | 5440BV ...* |
| M8  | B25.42.002 ...* | \emptyset 10  | 5440BW ...* |
| Profile mk 2025.43  | | M12  | 5440AA ...* |
| Services | Details | M12  | 5440AB ...* |
| M8  | B25.43.002 ...* | M8  | B54.40.002 ...* |
| Profile mk 2025.44  | | M8  | B54.40.001 ...* |
| Services | Details | M10  | B54.40.004 ...* |
| 3 x M8  | B25.44.002 ...* | Profile mk 2040.01  | |
| | | Services | Details |
| | |  | 5401AI ...* |
| | | α and β  | α, β 5401AF ...* |
| | | \emptyset 10  | 5401BA ...* |
| | | \emptyset 10  | 5401BB ...* |
| | | \emptyset 10  | 5401BV ...* |
| | | \emptyset 10  | 5401BW ...* |







...* Profile length in mm



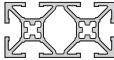





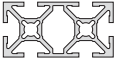

Profile Services

End Services











Series 40







| Profile mk 2040.01  | | | |
|--|---|---------|------------------------|
| Services | | Details | |
| M12 |  | | 5401AA ...* |
| M12 |  | | 5401AB ...* |
| M8 |  | | B54.01.003 ...* |
| M8 |  | | B54.01.002 ...* |
| M10 |  | | B54.01.001 ...* |



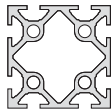



| Profile mk 2040.52  | | | |
|--|---|-----------------|--------------------|
| Services | | Details | |
| α and β |  | α, β | 5452AH ...* |
| \emptyset 10 |  | Location | 5452BV ...* |
| \emptyset 10 |  | Location | 5452BW ...* |
| M8 |  | | 5452AA ...* |
| M8 |  | | 5452AB ...* |

| Profile mk 2040.41  | | | |
|--|---|-----------------|------------------------|
| Services | | Details | |
| |  | | 5441AI ...* |
| α and β |  | α, β | 5441AH ...* |
| \emptyset 10 |  | Location | 5441BA ...* |
| \emptyset 10 |  | Location | 5441BB ...* |
| \emptyset 10 |  | Location | 5441BV ...* |
| \emptyset 10 |  | Location | 5441BW ...* |
| M12 |  | | 5441AC ...* |
| M12 |  | | 5441AB ...* |
| M8 |  | | B54.41.002 ...* |
| M8 |  | | B54.41.001 ...* |

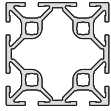
Series 40

| Profile mk 2040.02  | | | |
|--|--|-----------------|------------------------|
| Services | | Details | |
| |  | | 5402AI ...* |
| α and β |  | α, β | 5402AH ...* |
| \emptyset 10 |  | Location | 5402BA ...* |
| \emptyset 10 |  | Location | 5402BB ...* |
| \emptyset 10 |  | Location | 5402BV ...* |
| \emptyset 10 |  | Location | 5402BW ...* |
| M12 |  | | 5402AA ...* |
| M12 |  | | 5402AB ...* |
| M8 |  | | B54.02.002 ...* |
| M8 |  | | B54.02.001 ...* |

| Profile mk 2040.03  | | | |
|--|--|-----------------|------------------------|
| Services | | Details | |
| α and β |  | α, β | 5403AF ...* |
| 4x M12 |  | | 5403AA ...* |
| 4x M12 |  | | 5403AB ...* |
| 4x M8 |  | | B54.03.002 ...* |
| 4x M8 |  | | B54.03.001 ...* |











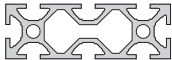











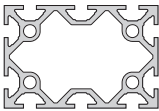







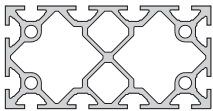

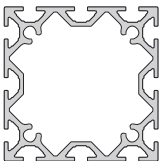

| Profile mk 2040.45  | | | |
|--|--|-----------------|------------------------|
| Services | | Details | |
| α and β |  | α, β | 5445AF ...* |
| 4x M12 |  | | 5445AA ...* |
| 4x M12 |  | | 5445AB ...* |
| 4x M8 |  | | B54.45.002 ...* |
| 4x M8 |  | | B54.45.001 ...* |

...* Profile length in mm

Structural Profiles

Profile Services

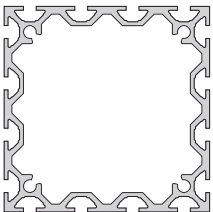
End Services

| Series 40 | | Series 40 | |
|--|-----------------------------|--|-----------------------------|
| Profile mk 2040.05  | | Profile mk 2040.21  | |
| Services | Details | Services | Details |
| ∅ 10  | Location 5405BB ...* |  | 5421AI ...* |
| M8  | B54.05.001 ...* | ∅ 10  | Location 5421BB ...* |
| Profile mk 2040.06  | | ∅ 10  | |
| Services | Details | Location | 5421BW ...* |
| ∅ 10  | Location 5406BB ...* | M12  | 5421AA ...* |
| M8  | B54.06.001 ...* | M8  | B54.21.001 ...* |
| Profile mk 2040.07  | | Profile mk 2040.11  | |
| Services | Details | Services | Details |
| 4x M8  | B54.07.001 ...* |  | 5411AI ...* |
| | | ∅ 10  | 5411BB ...* |
| | | ∅ 10  | 5411BW ...* |
| | | M12  | 5411AA ...* |
| | | M8  | B54.11.001 ...* |
| Profile mk 2040.08  | | Profile mk 2040.14  | |
| Services | Details | Services | Details |
| 4x M8  | B54.08.001 ...* | ∅ 10  | 5414BB ...* |
| | | ∅ 10  | 5414BW ...* |
| | | M12  | 5414AA ...* |
| | | M8  | B54.14.001 ...* |
| Profile mk 2040.10  | | Profile mk 2040.15  | |
| Services | Details | Services | Details |
| 4x M8  | B54.10.001 ...* | ∅ 10  | 5415BB ...* |
| | | ∅ 10  | 5415BW ...* |
| | | M12  | 5415AA ...* |
| | | M8  | B54.15.001 ...* |
| Profile mk 2040.09  | | | |
| Services | Details | | |
| 4x M8  | B54.09.001 ...* | | |

...* Profile length in mm

Profile Services

End Services

Series 40

Profile mk 2040.12

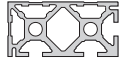

| Services | Details |
|--|------------------------|
| M8  | B54.12.001 ...* |

Profile mk 2040.46

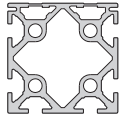

| Services | Details |
|---|------------------------|
| 4x M8  | B54.46.001 ...* |

Profile mk 2040.13

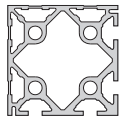

| Services | Details |
|---|------------------------|
| 4x M8  | B54.13.001 ...* |

Profile mk 2040.16



| Services | Details |
|--|--------------------|
| M8  | 5416AB ...* |

Series 50





Profile mk 2001



| Services | Details |
|---|--------------------|
| M8  | 5101AA ...* |

Profile mk 2000



| Services | Details |
|---|------------------------------------|
| α and β  | α, β 5100AF ...* |
| \emptyset 10  | 5100BG ...* |
| 4x M8  | 5100AC ...* |
| 4x M8  | 5100AD ...* |

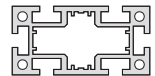

Profile mk 2004



| Services | Details |
|--|--------------------|
|  | 5104AI ...* |
| 4x M8  | 5104AA ...* |
| 4x M8  | 5104AC ...* |

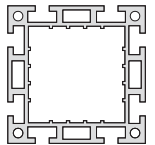

Profile mk 2005

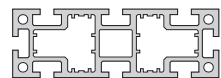

| Services | Details |
|--|--------------------|
|  | 5105AI ...* |
| 4x M8  | 5105AB ...* |
| 4x M8  | 5105AA ...* |

Profile mk 2006













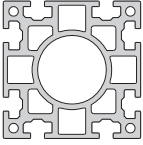







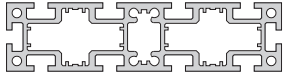
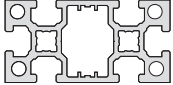



| Services | Details |
|--|--------------------|
| 4x M8  | 5106AA ...* |
| 4x M8  | 5106AB ...* |

...* Profile length in mm

Structural Profiles

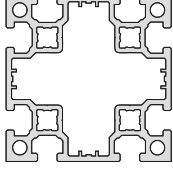
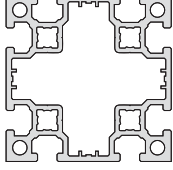
Profile Services

End Services

| Series 50 | | Series 60 | |
|--|--------------------|--|------------------------------------|
| <p>Profile mk 2011</p>  | | <p>Profile mk 2060.01</p>  | |
| Services | Details | Services | Details |
| 4x M8  | 5111AA ...* | α and β  | α, β 6001AF ...* |
| 4x M8  | 5111AB ...* | 4x M12  | 6001AA ...* |
| | | 4x M12  | 6001AB ...* |
| | | M12  | B60.01.606 ...* |
| <p>Profile mk 2008</p>  | | <p>Profile mk 2060.02</p>  | |
| Services | Details | Services | Details |
| 4x M8  | 5108AA ...* | 4x M12  | 6002AA ...* |
| 4x M8  | 5108AB ...* | 4x M12  | 6002AB ...* |
| | | 4x M8  | B60.02.601 ...* |
| <p>Profile mk 2003</p>  | | <p>Profile mk 2060.03</p>  | |
| Services | Details | Services | Details |
| M8  | 5103AA ...* | 4x M12  | 6003AB ...* |
| <p>Profile mk 2060.05</p>  | | <p>Profile mk 2060.05</p>  | |
| Services | Details | Services | Details |
| 4x M12  | 6005AA ...* | 4x M12  | 6005AB ...* |
| 4x M12  | 6005AB ...* | 4x M12  | B60.05.605 ...* |

...* Profile length in mm











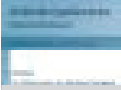

Profile Services

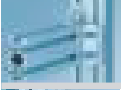
Threads and Inserts

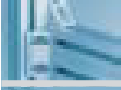
mk offers services tapping holes or placing inserts. Please refer to the following table for details regarding the recommended tools and available threaded inserts. The services can be performed using a hand drill. The insert tools are designed for manual operation.

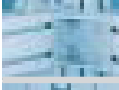
| Service | for Series | ø Hole | Tools  | Req. Thread length | Order-Nr. Tools | Order-Nr. Threaded Insert |
|---------------------|----------------|---------|--|--------------------|--------------------------|---------------------------|
| Thread M5 | 25 | 4.2 mm | Tap M5 | 15 mm | K903060005 | |
| Thread M10 | 25 | 8.5 mm | Tap M10 | 30 mm | K903060010 | |
| Threaded Insert M3 | 25 | 4.2 mm | Tap M5x0.5 mm, Installation Tool | 10 mm | K903060105 K902010004 | K112030002 |
| Threaded Insert M6 | 25 | 8.5 mm | Tap M9x1 mm, Installation Tool | 15 mm | K903060109 K902010010 | K112030006 |
| Helicoil M4 | 25 | 4.2 mm | Helicoil Tap M4, Installation Tool | 10 mm | K903060204 K902010204 | K112030104 |
| Helicoil M8 | 25 | 8.5 mm | Helicoil Tap M8, Installation Tool | 15 mm | K903060208 K902010208 | K112030109 |
| Thread M8 | 40 extra light | 7.4 mm | Threadformer M8 | 20 mm | K903070008 | |
| Thread M12 | 40 | 10.0 mm | Tap M12 | 35 mm | K903060012 | |
| Threaded Insert M8 | 40 | 10.0 mm | Tap M12x1.5 mm, Installation Tool | 20 mm | K903060113 K902010012 | K112030008 |
| Helicoil M10 | 40 | 10.0 mm | Helicoil Tap M10, Installation Tool | 20 mm | K903060210 K902010210 | K112030110 |
| Thread M8 | 50 | 7.0 mm | Tap M8 | 25 mm | K903060008 | |
| Threaded Insert M5 | 50 | 7.0 mm | Tap M8x1 mm, Installation Tool | 15 mm | K903060108 K902010008 | K112030005 |
| Helicoil M6 | 50 | 7.0 mm | Helicoil Tap M6, Installation Tool | 15 mm | K903060206 K902010206 | K112030106 |
| Thread M12 | 60 | 10.5 mm | Tap M12 | 35 mm | K903060012 | |
| Thread M16 | 60 | 14.5 mm | Tap M16 | 45 mm | K903060016 | |
| Threaded Insert M8 | 60 | 10.5 mm | Tap M12x1.5 mm, Installation Tool | 20 mm | K903060113 K902010012 | K112030008 |
| Threaded Insert M12 | 60 | 14.5 mm | Tap M16x1.5 mm, Installation Tool | 25 mm | K903060116 K902010016 | K112030010 |
| Helicoil M10 | 60 | 10.5 mm | Helicoil Tap M10, Installation Tool | 20 mm | K903060210 K902010210 | K112030110 |

Contents mk Assembly Components

| | | |
|---|--|-----|
|  | Selection criteria for Assembly Components | 85 |
|  | Angles | |
|  | Advantages Angles | 86 |
|  | Series 25, 90° | 88 |
|  | Series 40, 90° | 90 |
|  | Series 50, 90° | 94 |
|  | Series 60, 90° | 98 |
|  | Series 40/50, 30°/45°/60° | 100 |
|  | Adjustable Angles | 102 |
|  | Consoles | 104 |
|  | Internal Fasteners | 108 |
|  | Plates | 112 |
|  | Corner Blocks | 121 |













mk Assembly Components

Contents mk Assembly Components

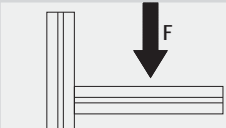
| | | |
|--|---------------------------------|-----|
|  | Profile Wedges | 129 |
|  | Angle Braces | 131 |
|  | Parallel Connectors | 132 |
|  | Clamps | 134 |
|  | Nuts | 136 |
|  | Grounding | 140 |
|  | Screws, Nuts and Spring Washers | 141 |

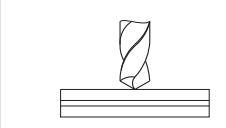
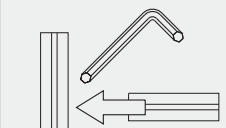
Assembly Components

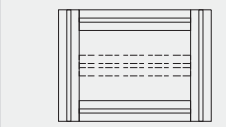
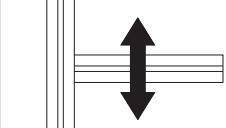
Selection criteria for Assembly Components

| Selection criteria | Assembly Components |  |  |  |  |  |  |  |
|---|---------------------|---|--|---|---|---|---|---|
| | | Angle / Console | Tension Plug Series 25, 40, 50 | Tension Plug Series 40/1, 40 light | Face Plate | Side Plate | Corner Block | Clamp |
|  High load bearing capacity | | + | + - | - | + | + | + | + - |
|  High moment bearing capacity | | + | + - | + - | + - | + | + - | - |
|  High torsional moment bearing capacity | | + | - | - | + - | + | - | + - |
|  Short processing time required | | + | + - | + - | + - | + | + - | + |
|  Short assembly time required | | + | + - | + - | + - | + | + - | + |
|  Low material costs | | + - | + | + | - | + - | - | + - |
|  Subsequent assembly between profiles | | + | - | - | + | + | - | - |
|  Subsequent movability | | + | + | only 40/1 | + | + | - | + |
|  T-slots free for paneling | | - | - | + | - | + | - | - |

Assembly Components

Angles

Advantages Angles

Angles

mk Angles are manufactured from extruded aluminum profiles (AlMgSi 0.7 F28) and are milled. They have a tumbled surface finish.

mk Angles are our most popular components. They also offer the possibility of combining profiles of different series.

The mounting hardware for the mk angle is made up of a DIN socket head cap screw, a ribbed washer and an mk nut. The nut holds the connection in the profile slot. The ribbed washer secures the screw against loosening under dynamic loads. **Use of ribbed washers in conjunction with socket or hex head screws is obligatory for mk products.**

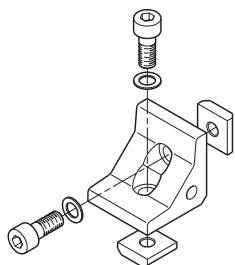

Angle kits including mounting hardware

mk also offers the most common angles as a complete kit including mounting hardware. They are denoted by the preceding T in the ID number.

The mounting hardware for the kits has been selected in such a way that the angles can be universally used for all the normal angled connections and include the required number of screws, ribbed washers and square nuts.

Keyed Angles

The keys in Angles Bs, Cs, Ds, Es, Fs, Gs, Hs, Js, Ks and S firmly hold the angle in the T-slot, thus preventing any rotation of the profile. In an assembly you can be assured of exact 90° connection. Keyed angles also significantly reduce assembly times.

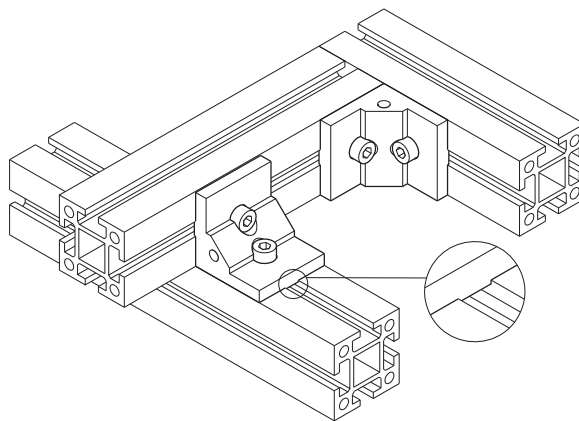

Angles and paneling

An M8 thread can be cut into the side holes of the angles to accommodate paneling such as Polycarbonate.

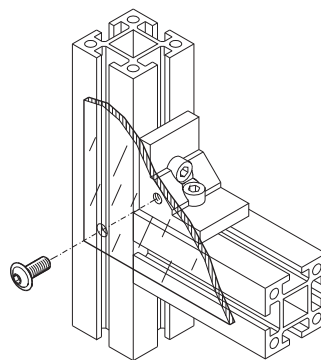

We can also produce special angles to your specifications using our angle profiles.

Examples

Series 25

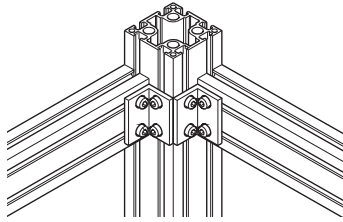

Profile mk 2025.05, mk 2025.02
 2 x Angle 40

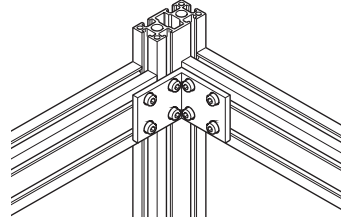

Profile mk 2025.02
 Angle A25/40/2

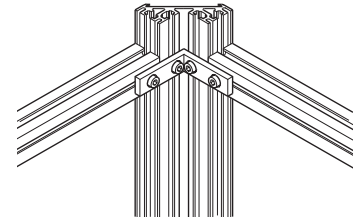

Profile mk 2025.25, 2025.01
 Angle A25/15/2

Series 40

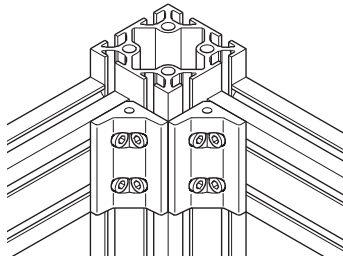

Profile mk 2040.02, 2040.03
 2 x Angle E80

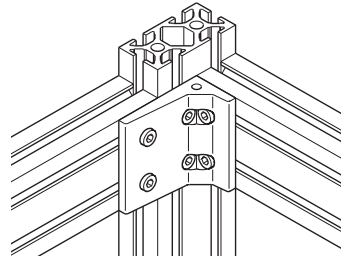

Profile mk 2040.02
 Angle F80

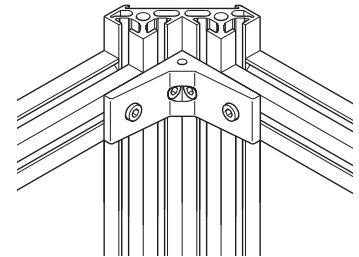

Profile mk 2040.04, 2040.01
 Angle G40

Series 50

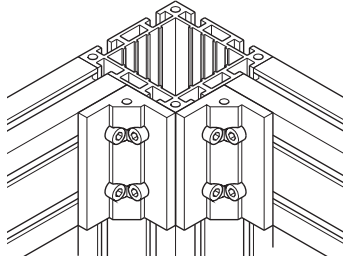

Profile mk 2005, mk 2004
 2 x Angle B100

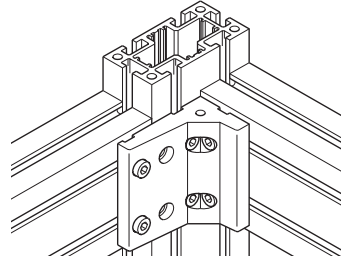

Profile mk 2004
 Angle D90/2

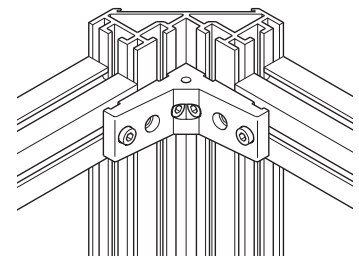

Profile mk 2072, mk 2000
 Angle C40/3

Series 60

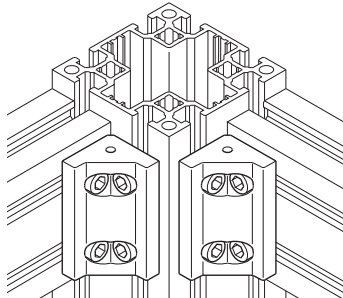

Profile mk 2060.02, mk 2060.05,
 2 x Angle H100

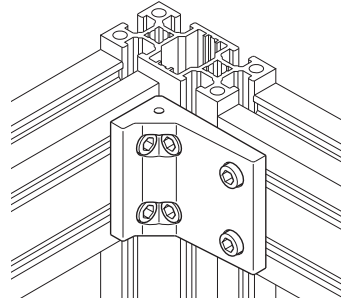

Profile mk 2060.02,
 Angle J100

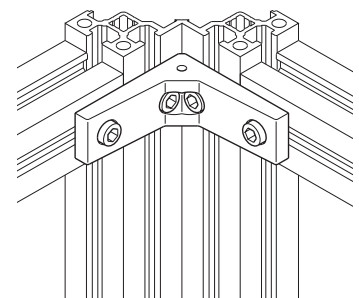

Profile mk 2060.01, mk 2060.22
 Angle K40

Assembly Components

Angles

Series 25



The angle kits include the necessary mounting hardware as shown in the example below.

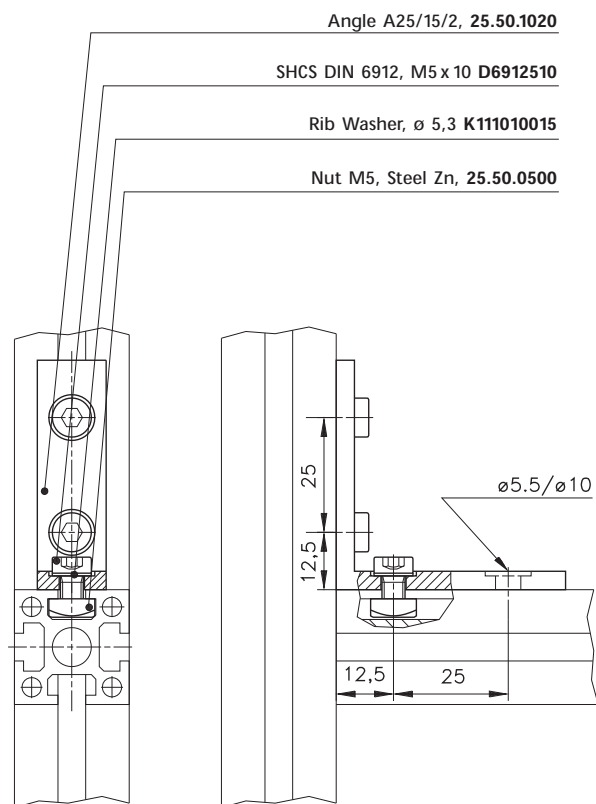

M5 x 10

DIN 6912

25 40 50 60

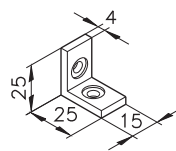

Angle 15
25.50.1000

Al tumbled

T25.50.1000

includes mounting hardware

25 40 50 60

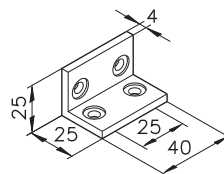

Angle 40
25.50.1001

Al tumbled

T25.50.1001

includes mounting hardware

25 40 50 60

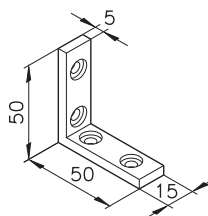

Angle A25/15/2
25.50.1020

Al tumbled

T25.50.1020

includes mounting hardware

25 40 50 60

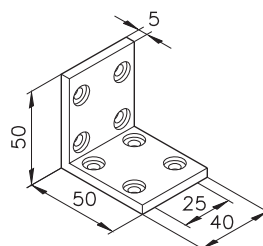

Angle A25/40/2
25.50.1021

Al tumbled

T25.50.1021

includes mounting hardware

Angles

Series 25



The angle kits include the necessary mounting hardware as shown in the example below.

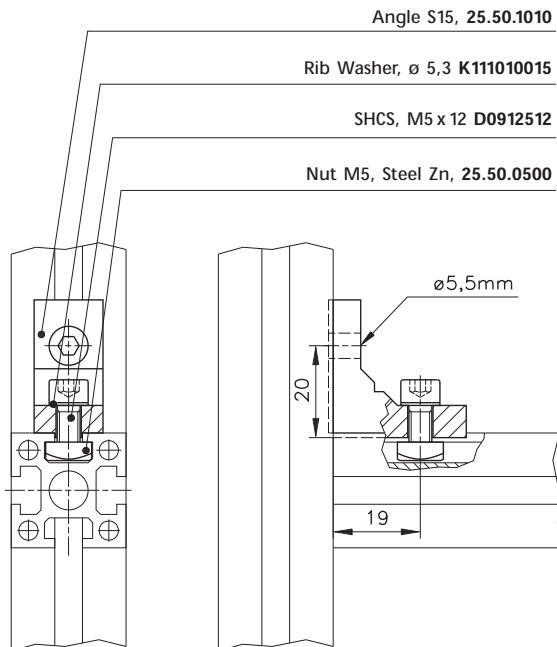

25 | 40 | 50 | 60

Angle S15

25.50.1010

Al tumbled

T25.50.1010

includes mounting hardware

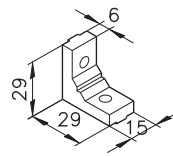

25 | 40 | 50 | 60

Angle S40

25.50.1012

Al tumbled

T25.50.1012

includes mounting hardware

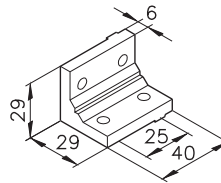

Assembly Components

Angles

Series 40

Angle P



25 40 50 60

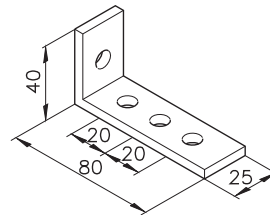

Angle P3
82.00.0024
Al tumbled

Angle E



25 40 50 60

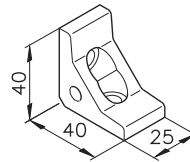

Angle E25
82.40.0701
Al tumbled
T82.40.0701
includes mounting hardware

25 40 50 60

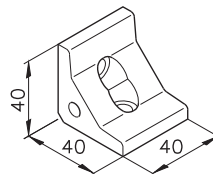

Angle E40
82.40.0702
Al tumbled
T82.40.0702
includes mounting hardware

25 40 50 60

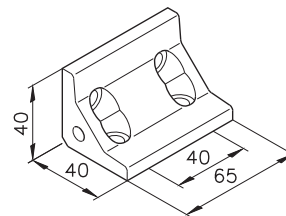

Angle E65
82.40.0704
Al tumbled
T82.40.0704
includes mounting hardware

25 40 50 60

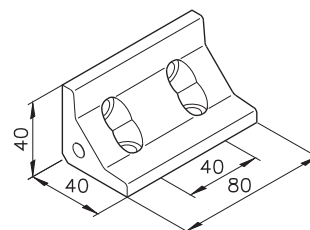

Angle E80
82.40.0703
Al tumbled
T82.40.0703
includes mounting hardware

The angle kits include the necessary mounting hardware as shown in the example below.

Angle F25, 82.40.0801

SHCS, M8 x 16 D0912816

Rib Washer, \varnothing 8.4 K111010017

Nut 1 M8, Steel Zn, 34.01.0001

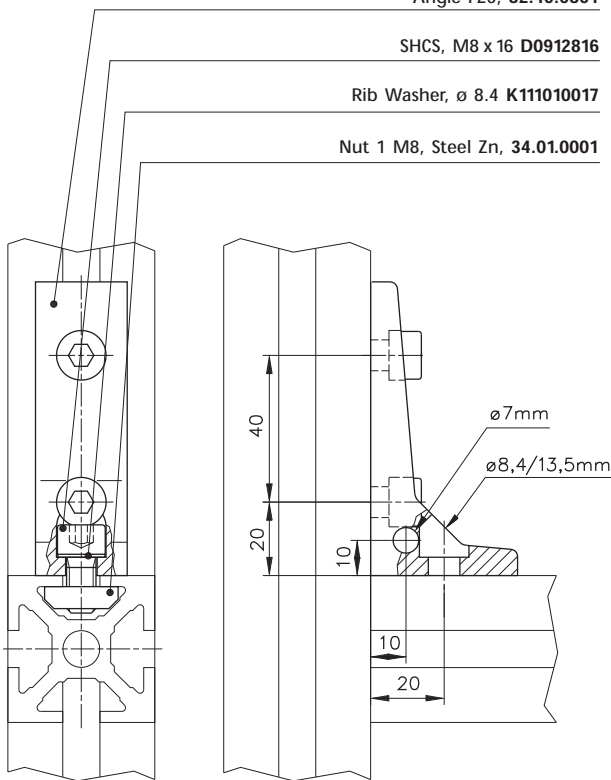

Angle P



25 40 50 60

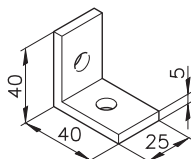

Angle P1
82.00.0023
Al tumbled

Angles

Series 40

Angle E

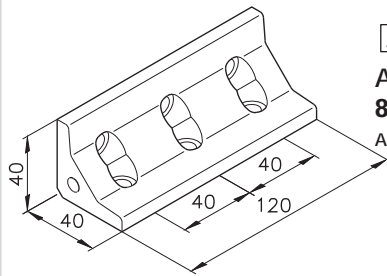

25 | 40 | 50 | 60

Angle E120
82.40.0705

Al tumbled

Angle Es

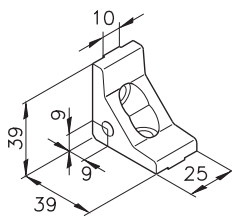

25 | 40 | 50 | 60

Angle E25s
82.40.0741

Al tumbled

T82.40.0741

includes mounting hardware

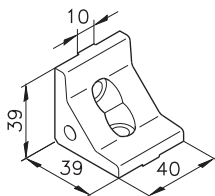

25 | 40 | 50 | 60

Angle E40s
82.40.0742

Al tumbled

T82.40.0742

includes mounting hardware

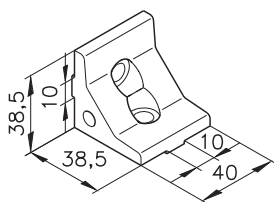

25 | 40 | 50 | 60

Angle E40s3
82.40.0747

Al tumbled

T82.40.0747

includes mounting hardware

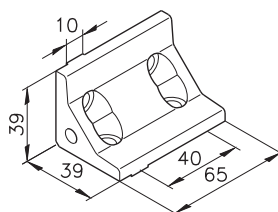

25 | 40 | 50 | 60

Angle E65s
82.40.0744

Al tumbled

T82.40.0744

includes mounting hardware

Angle F

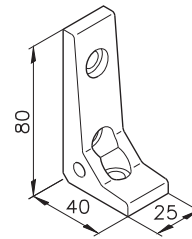

25 | 40 | 50 | 60

Angle F25
82.40.0801

Al tumbled

T82.40.0801

includes mounting hardware

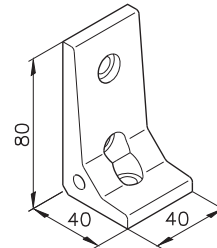

25 | 40 | 50 | 60

Angle F40
82.40.0802

Al tumbled

T82.40.0802

includes mounting hardware

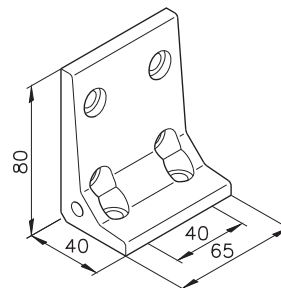

25 | 40 | 50 | 60

Angle F65
82.40.0804

Al tumbled

T82.40.0804

includes mounting hardware

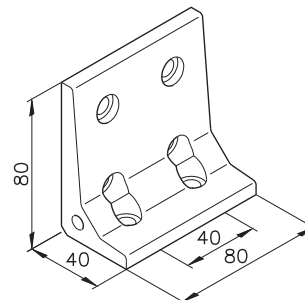

25 | 40 | 50 | 60

Angle F80
82.40.0803

Al tumbled

T82.40.0803

includes mounting hardware

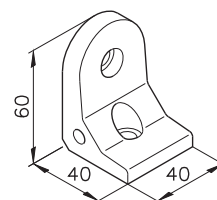

25 | 40 | 50 | 60

Angle F40/R
82.40.0805

Al tumbled

T82.40.0805

includes mounting hardware

for fixing panels to posts

Assembly Components

Angles

Series 40

Angle Fs

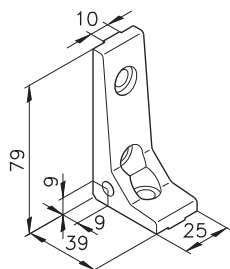

25 40 50 60

Angle F25s
82.40.0841
 Al tumbled
T82.40.0841
 includes mounting hardware

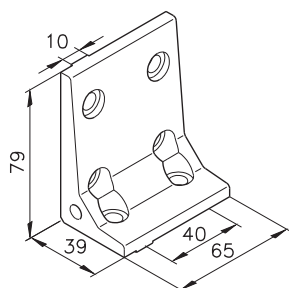

25 40 50 60

Angle F65s
82.40.0844
 Al tumbled
T82.40.0844
 includes mounting hardware

Angle G

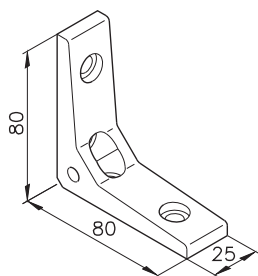

25 40 50 60

Angle G25
82.40.0901
 Al tumbled
T82.40.0901
 includes mounting hardware

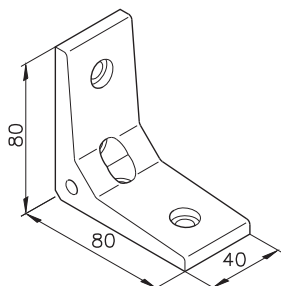

25 40 50 60

Angle G40
82.40.0902
 Al tumbled
T82.40.0902
 includes mounting hardware

Angle G

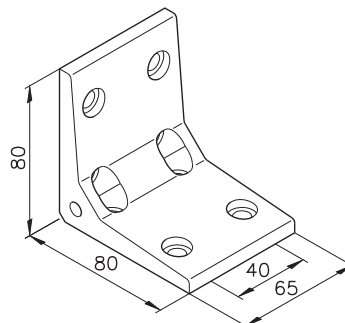

25 40 50 60

Angle G65
82.40.0904
 Al tumbled
T82.40.0904
 includes mounting hardware

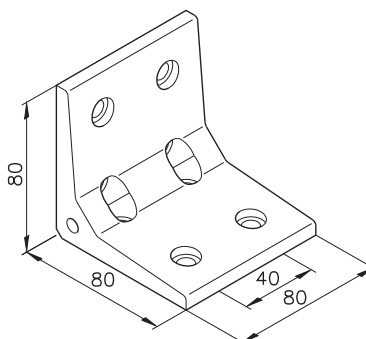

25 40 50 60

Angle G80
82.40.0903
 Al tumbled
T82.40.0903
 includes mounting hardware

Angle Gs

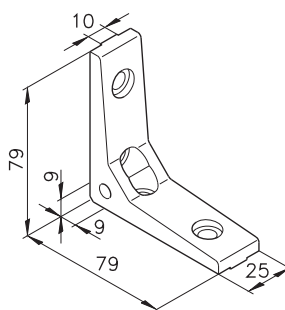

25 40 50 60

Angle G25s
82.40.0941
 Al tumbled
T82.40.0941
 includes mounting hardware

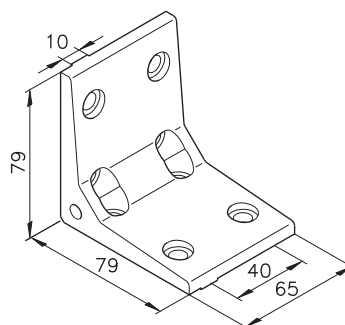

25 40 50 60

Angle G65s
82.40.0942
 Al tumbled
T82.40.0942
 includes mounting hardware



Angles

Series 40

Plastic Angle

The plastic angle is used for assemblies where the emphasis is focused more on an attractive design and less on high loads.

Angle R40 feature detents which prevent profile twist. These detents can be easily removed if connecting profiles with closed T-slots.

Cover, ABS GF15 black

Angle R40, ABS GF15 black

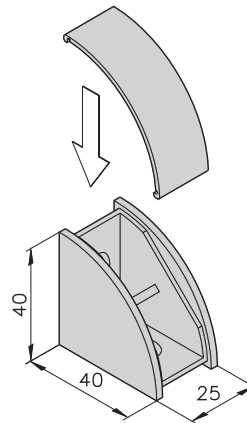
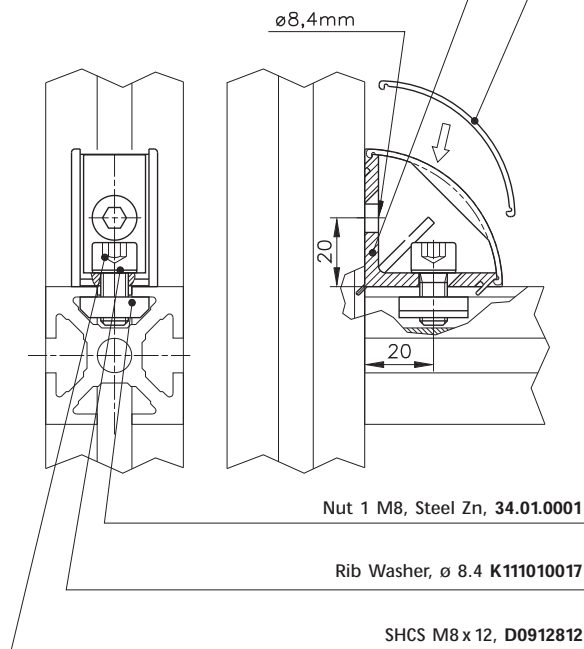

M8x12

25 40 50 60

Angle R40
B46.00.041

ABS GF15

black

Assembly Components

Angles

Series 50

Angle A

M8x16

25 | 40 | 50 | 60

Angle A1
82.02.0001
Al tumbled

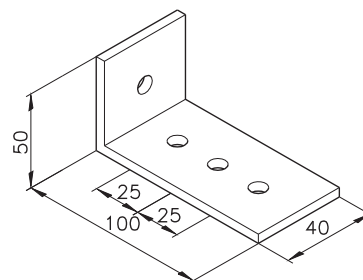
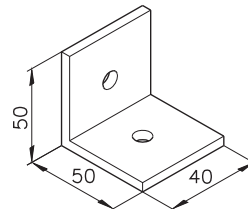

25 | 40 | 50 | 60

Angle A3
82.03.0001
Al tumbled

The angle kits include the necessary mounting hardware as shown in the example below.

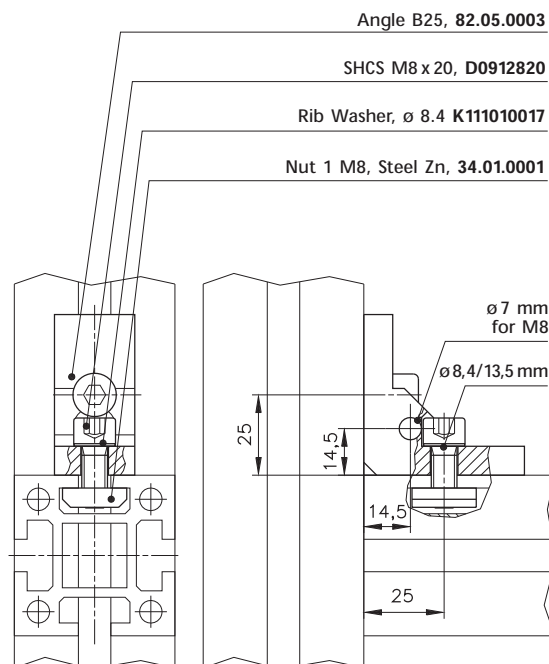

Angle B

M8x20

25 | 40 | 50 | 60

Angle B25
82.05.0003
Al tumbled

T82.05.0003
includes mounting hardware

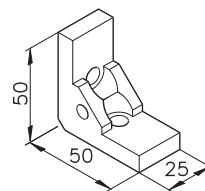

25 | 40 | 50 | 60

Angle B40
82.05.0013
Al tumbled

T82.05.0013
includes mounting hardware

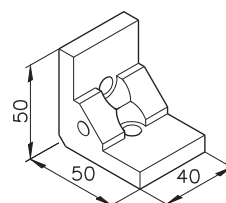

Angles

Series 50

Angle B

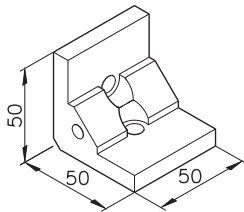

25 | 40 | **50** | 60

Angle B50
82.05.0004
 Al tumbled
T82.05.0004
 includes mounting hardware

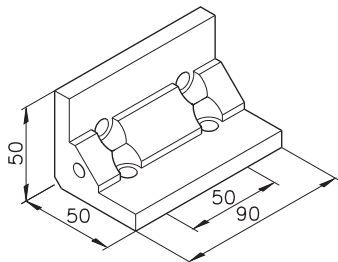

25 | 40 | **50** | 60

Angle B90
82.05.0022
 Al tumbled
T82.05.0022
 includes mounting hardware

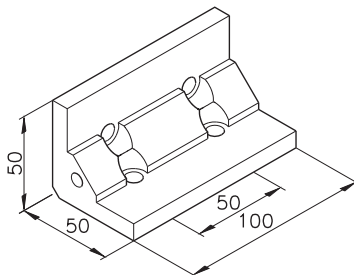

25 | 40 | **50** | 60

Angle B100
82.05.0006
 Al tumbled
T82.05.0006
 includes mounting hardware

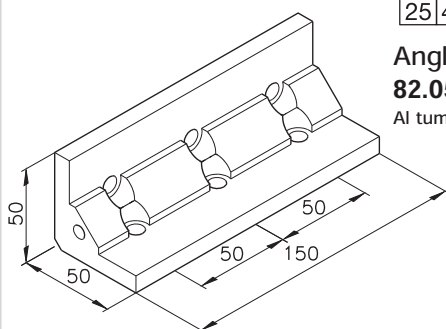

25 | 40 | **50** | 60

Angle B150
82.05.0012
 Al tumbled

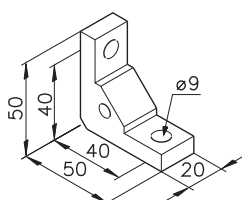

25 | 40 | **50** | 60

Angle B20/40
82.05.0026
 Al tumbled
T82.05.0026
 includes mounting hardware
 for fixing panels to posts

Angle Bs

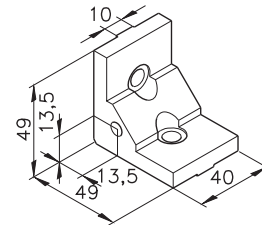

25 | 40 | **50** | 60

Angle B40s2
82.05.0055
 Al tumbled
T82.05.0055
 includes mounting hardware

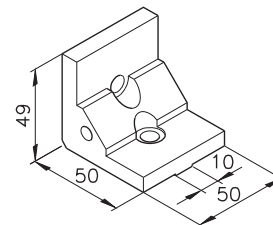

25 | 40 | **50** | 60

Angle B50s1
82.05.0051
 Al tumbled
T82.05.0051
 includes mounting hardware

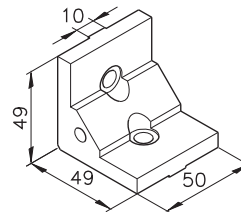

25 | 40 | **50** | 60

Angle B50s2
82.05.0052
 Al tumbled
T82.05.0052
 includes mounting hardware

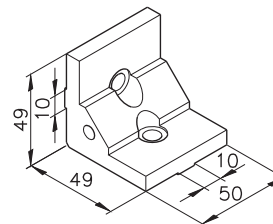

25 | 40 | **50** | 60

Angle B50s3
82.05.0053
 Al tumbled
T82.05.0053
 includes mounting hardware

Assembly Components

Angles

Series 50

Angle C

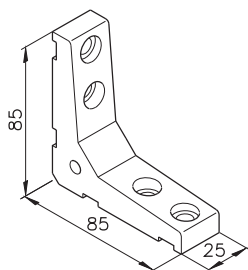

25 40 50 60

Angle C25
82.06.0001
 Al tumbled
T82.06.0001
 includes mounting hardware

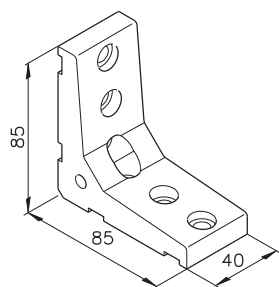

25 40 50 60

Angle C40/3
82.06.0014
 Al tumbled

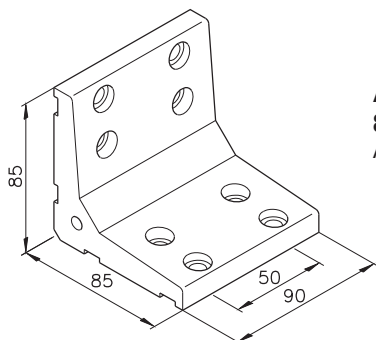

25 40 50 60

Angle C90
82.06.0003
 Al tumbled

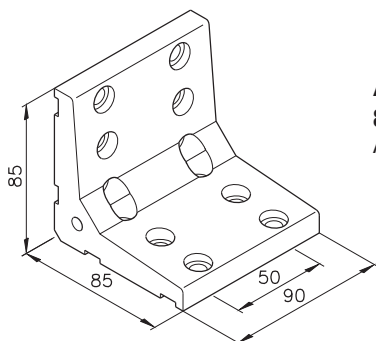

25 40 50 60

Angle C90/2
82.06.0009
 Al tumbled

Angle C

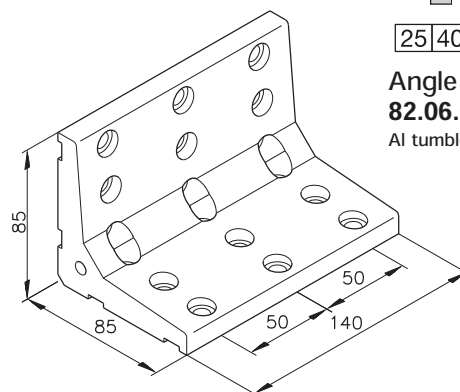

25 40 50 60

Angle C140/2
82.06.0010
 Al tumbled

Angle Cs

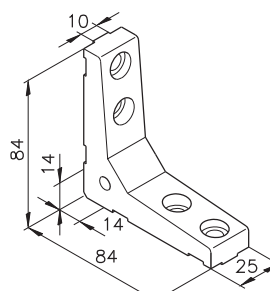

25 40 50 60

Angle C25s
82.06.0040
 Al tumbled
T82.06.0040
 includes mounting hardware

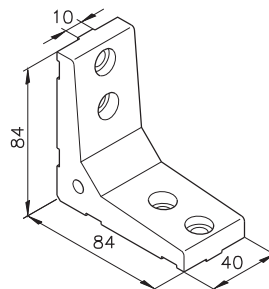

25 40 50 60

Angle C40s
82.06.0041
 Al tumbled
T82.06.0041
 includes mounting hardware

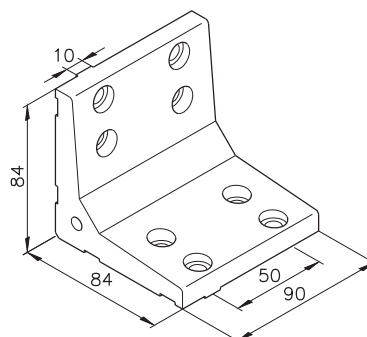

25 40 50 60

Angle C90s
82.06.0042
 Al tumbled

Angles

Series 50

Angle D

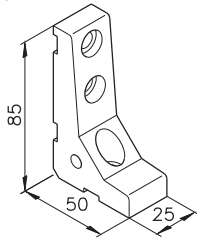

25 40 50 60

Angle D25

82.07.0001

Al tumbled

T82.07.0001

includes mounting hardware

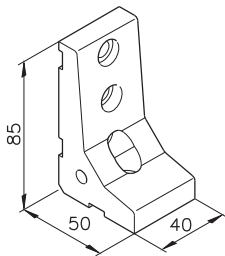

25 40 50 60

Angle D40/3

82.07.0013

Al tumbled

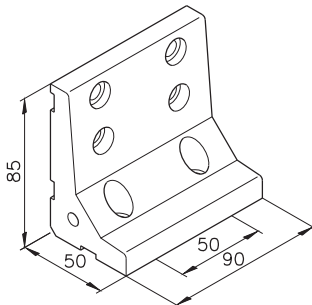

25 40 50 60

Angle D90

82.07.0003

Al tumbled

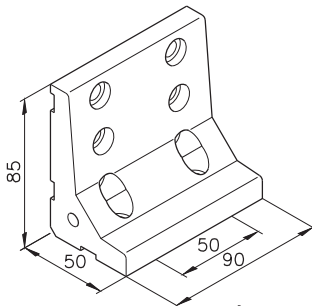

25 40 50 60

Angle D90/2

82.07.0009

Al tumbled

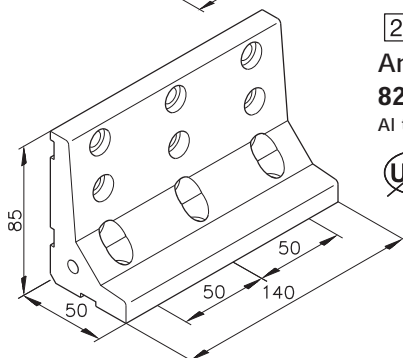

25 40 50 60

Angle D140/2

82.07.0010

Al tumbled



Angle Ds

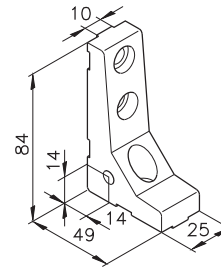

25 40 50 60

Angle D25s

82.07.0040

Al tumbled

T82.07.0040

includes mounting hardware

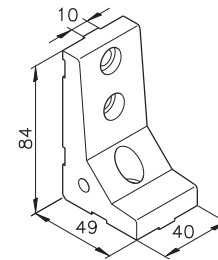

25 40 50 60

Angle D40s

82.07.0041

Al tumbled

T82.07.0041

includes mounting hardware

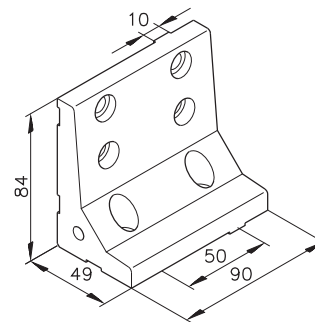

25 40 50 60

Angle D90s

82.07.0042

Al tumbled



Assembly Components

Angles

Series 60

Angle H



25 40 50 60

Angle H40
82.60.0701
Al tumbled

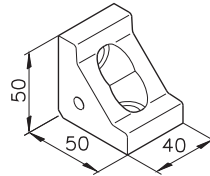

25 40 50 60

Angle H100
82.60.0702
Al tumbled

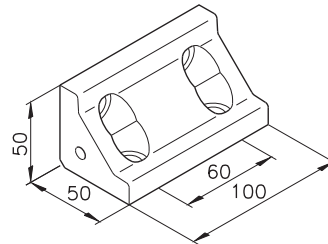

Angle J40, 82.60.0801

SHCS M12 x 25, D09121225

Rib Washer, ϕ 12.9 K111010019

Nut 1 M12, Steel Zn, 34.60.0301

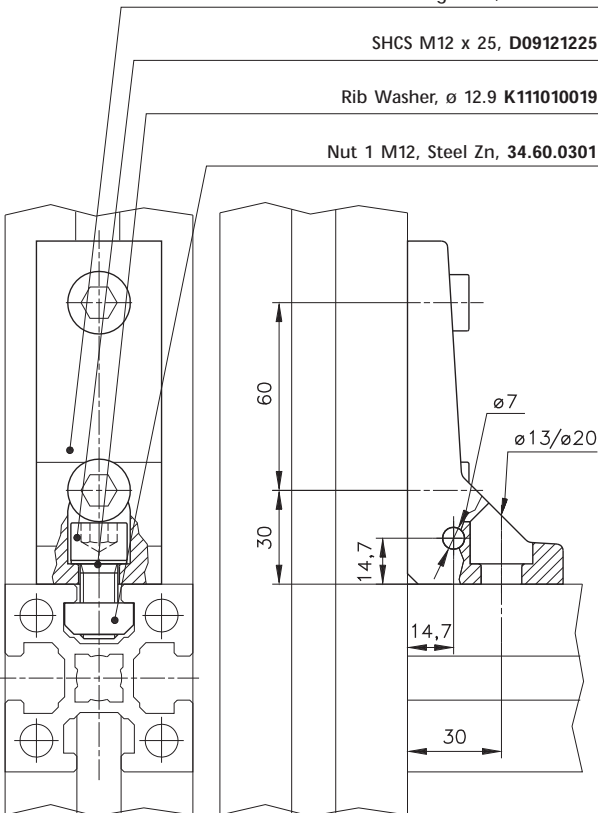

Angle Hs



25 40 50 60

Angle H40s
82.60.0741
Al tumbled

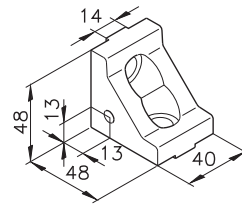

25 40 50 60

Angle H100s
82.60.0742
Al tumbled

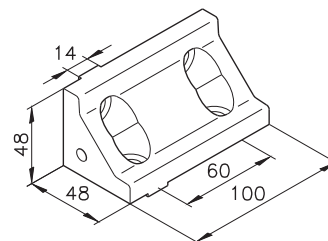

Angles

Series 60

Angle J

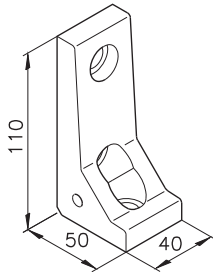

25 | 40 | 50 | 60

Angle J40
82.60.0801
 Al tumbled

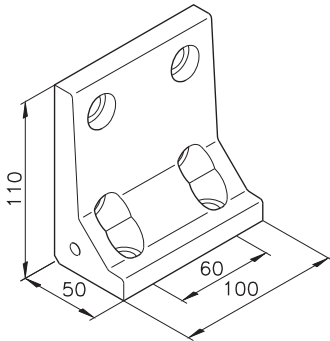

25 | 40 | 50 | 60

Angle J100
82.60.0802
 Al tumbled

Angle K

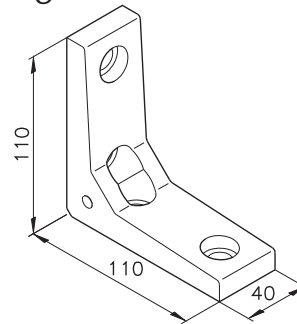

25 | 40 | 50 | 60

Angle K40
82.60.0901
 Al tumbled

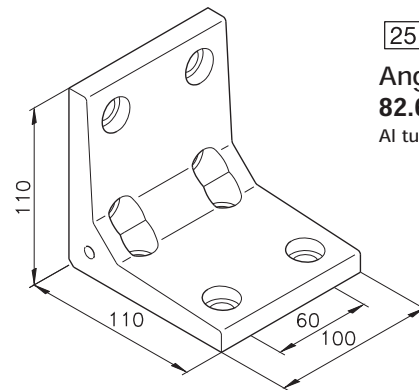

25 | 40 | 50 | 60

Angle K100
82.60.0902
 Al tumbled

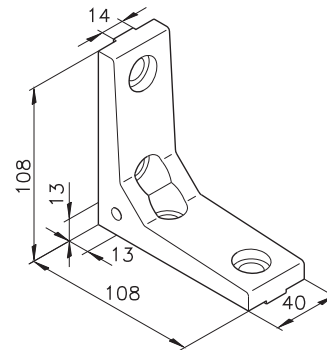

25 | 40 | 50 | 60

Angle K40s
82.60.0941
 Al tumbled

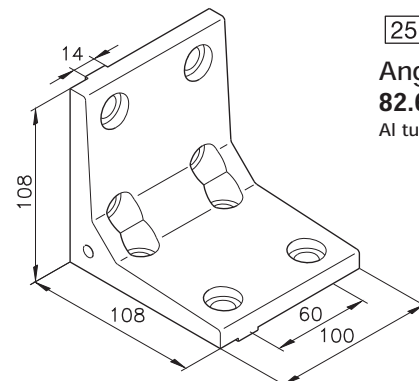

25 | 40 | 50 | 60

Angle K100s
82.60.0942
 Al tumbled

Assembly Components

Angles

Series 40 and 50

In addition to connecting profiles at standard angles, the L (30°), M (45°) and N (60°) angles are ideal for corner stiffening. In large, right-angled bracing assemblies, either two M angles or one L and one N angle always correspond to each other. All profiles are thus automatically aligned. The keys in the M25s angle ensure the profiles cannot twist.

Angle M25s

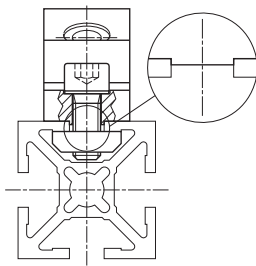

Angle M25

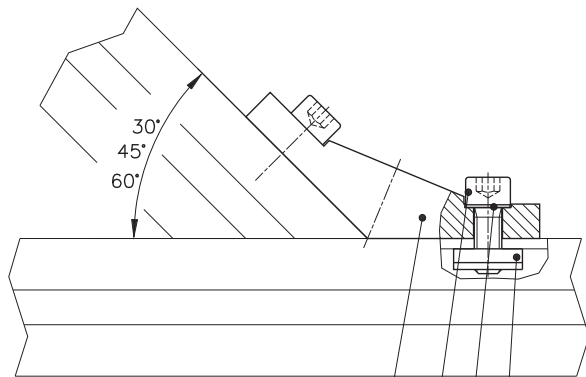
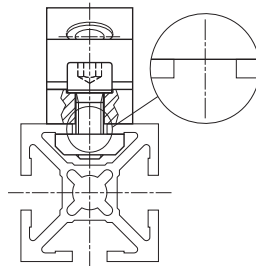

Angle 82.11.4001 Al tumbled

SHCS M8 x20, D0912820

Ribbed Washer, \varnothing 8.4 K111010017

Nut 1 M8, Steel Zn, 34.01.0001

M8x20

25 40 50 60

Angle L25
82.10.4001

Al tumbled

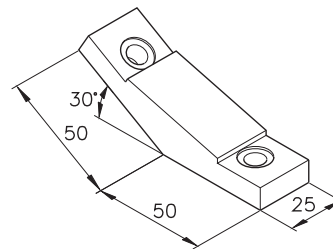

25 40 50 60

Angle M25
82.11.4001

Al tumbled

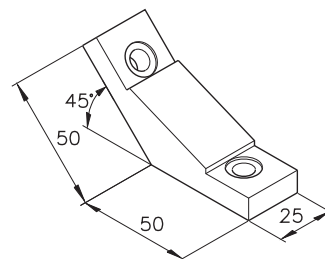

Angle M25s
82.11.4041

Al tumbled

keyed angle

25 40 50 60

Angle N25
82.12.4001

Al tumbled

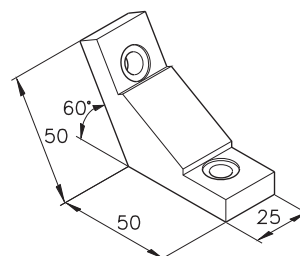

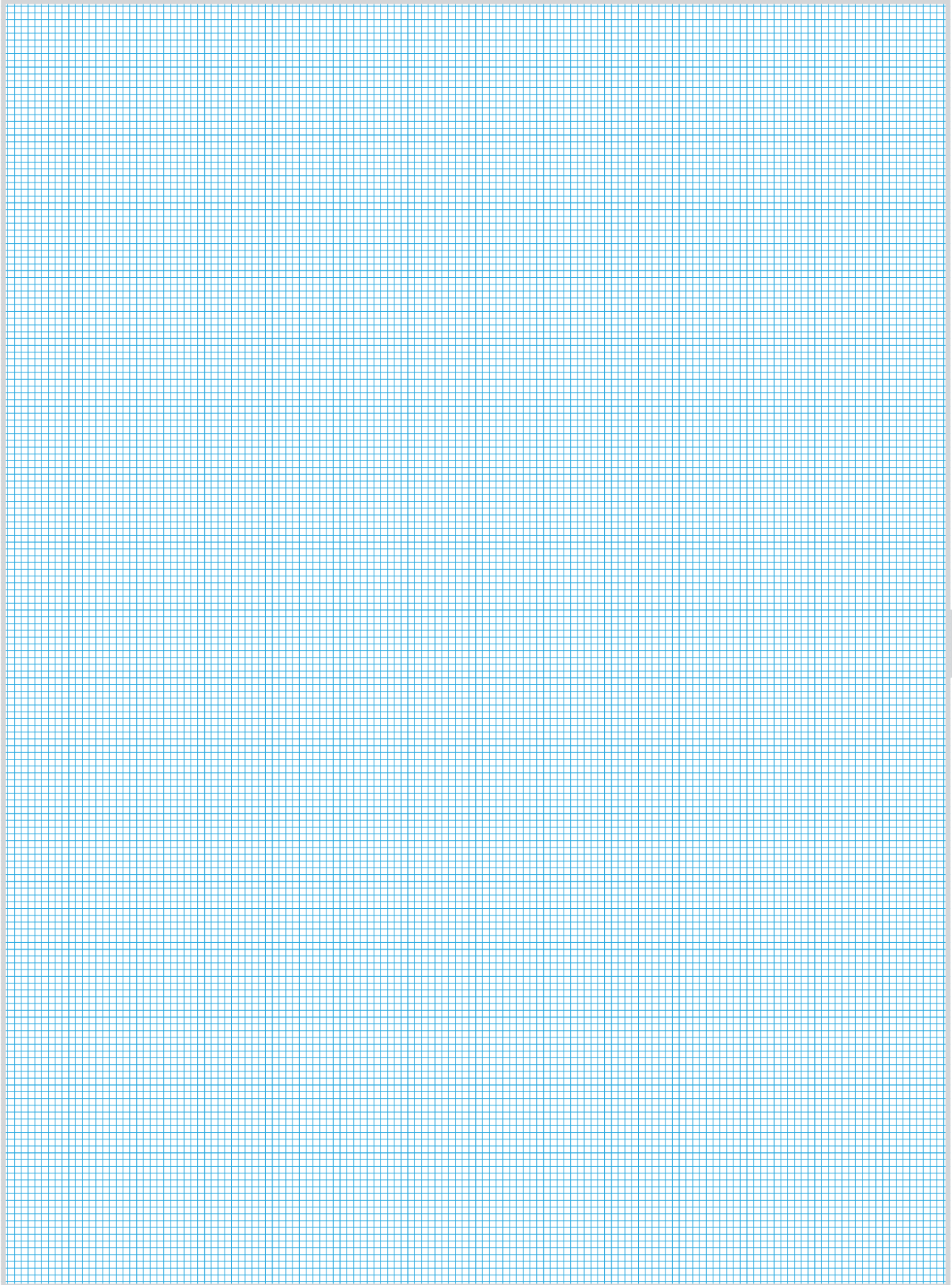



Installation example Series 40

Nut 1 M8, Steel Zn, 34.01.0001

Ribbed Washer \varnothing 8.4 Zn, K111010017

Hex Head Screw, M8 x 20, D0933820

*Spring Pin 4 x 24, D1481424

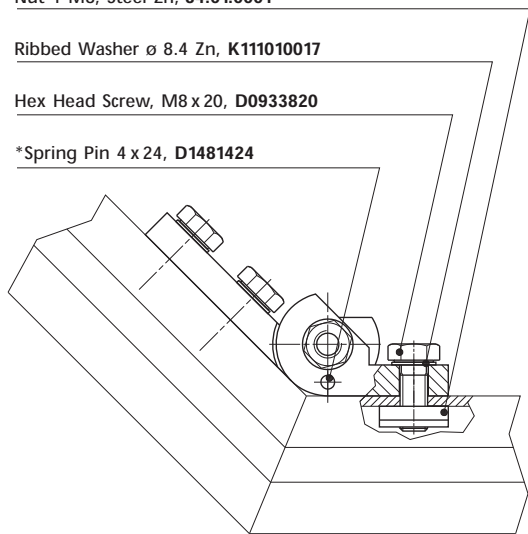

*Order separately. Adjustable Angles can be pinned at pre-set positions.

Assembly Components

Angles

Adjustable Angles

Adjustable Angles attach profiles at non-standard angles. If desired, the angles can be pinned to a preset position prior to assembly. When DIN EN ISO 4017 (hex head) screws are used the adjustment range is 0°-205°.



25 | 40 | 50 | 60

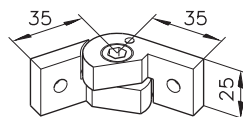

Adjustable Angles

A25/1

B46.00.035

as shown

B46.00.025

includes mounting hardware
without spring pin

25 | 40 | 50 | 60

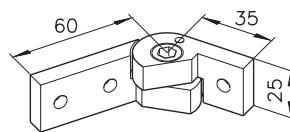

Adjustable Angles

A25/2

B46.00.036

as shown

B46.00.026

includes mounting hardware
without spring pin

25 | 40 | 50 | 60

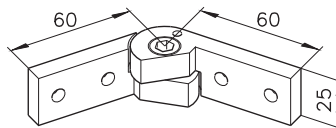

Adjustable Angles

A25/3

B46.00.034

as shown

B46.00.024

includes mounting hardware
without spring pin

Angles

Adjustable Angles

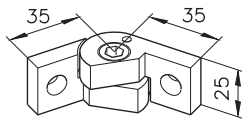

25 | 40 | 50 | 60

Adjustable Angles B25

B46.00.033

as shown

B46.00.021

includes mounting hardware
without spring pin

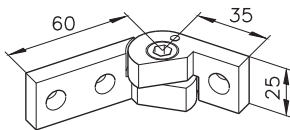

25 | 40 | 50 | 60

Adjustable Angles C25

B46.00.037

as shown

B46.00.027

includes mounting hardware
without spring pin

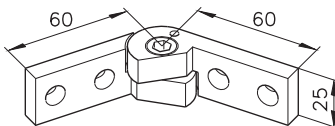

25 | 40 | 50 | 60

Adjustable Angles D25

B46.00.032

as shown

B46.00.020

includes mounting hardware
without spring pin

Assembly Components

Consoles

Cast Consoles

Series 50

For frames with high static loads, the mk consoles are a sound alternative to the mk angles. The consoles are made of cast aluminum and milled square.



Series 40

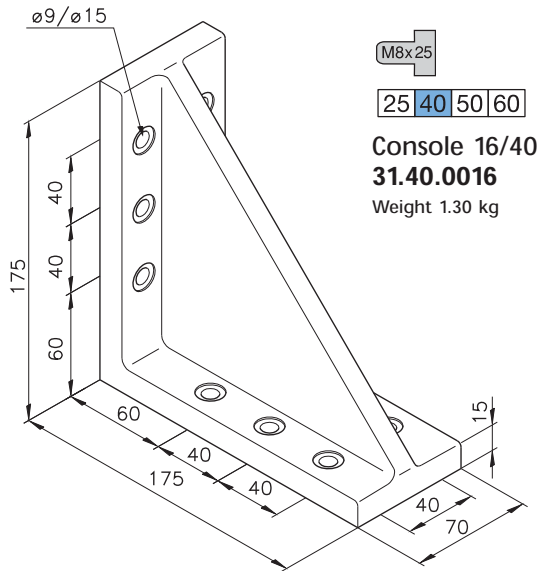

25 40 50 60

Console 16/40
31.40.0016
 Weight 1.30 kg



25 40 50 60

Console 1
31.00.0001
 Weight 0.25 kg

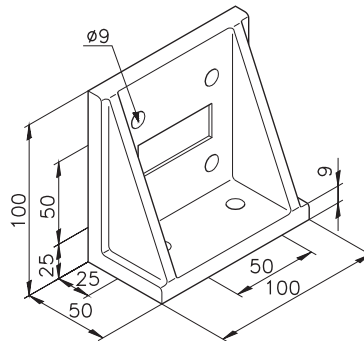
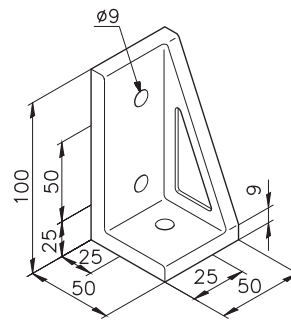

25 40 50 60

Console 2
31.00.0002
 Weight 0.50 kg

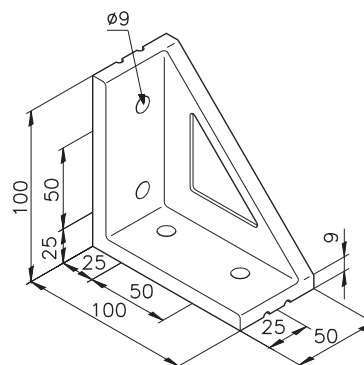

25 40 50 60

Console 4
31.00.0004
 Weight 0.35 kg

Consoles

Cast Consoles

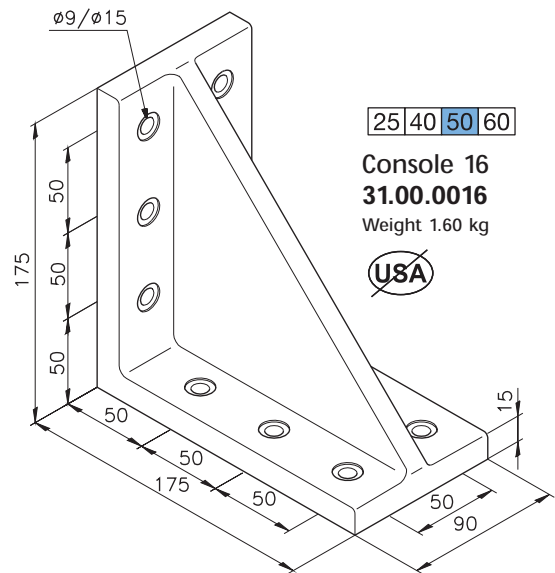
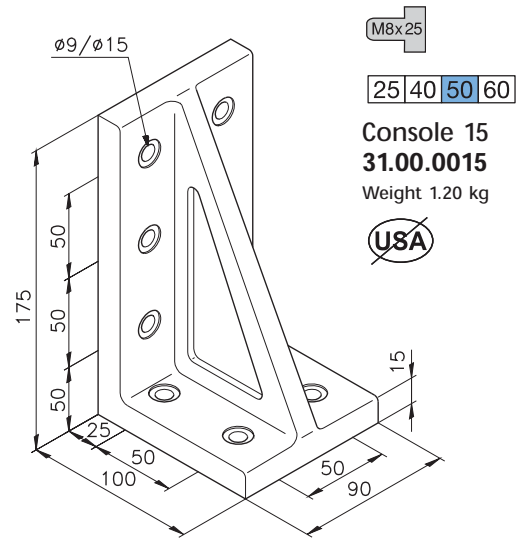
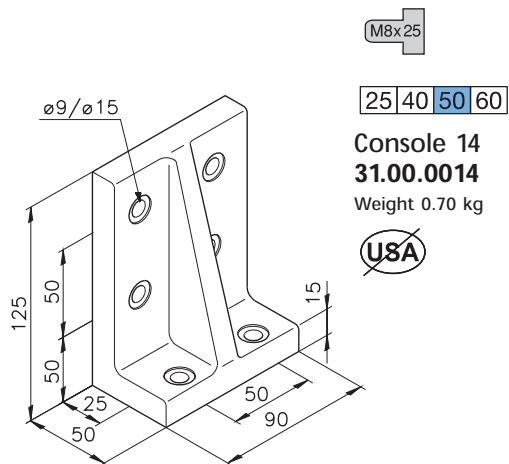
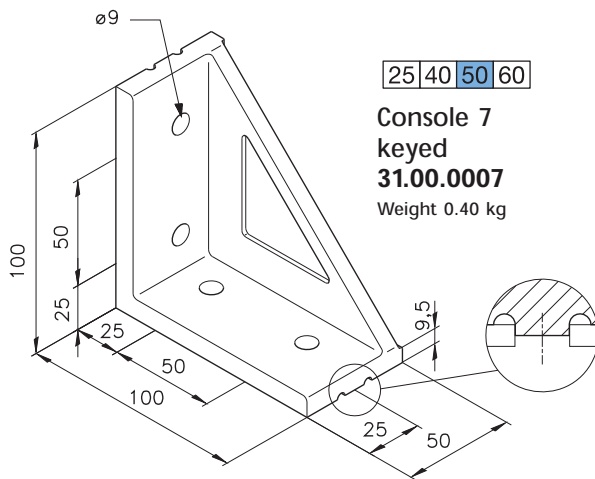
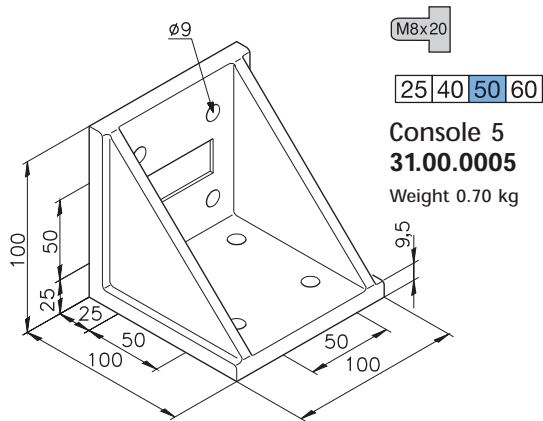

Assembly Components

Consoles

Cast Consoles

Series 60

For framing with high static loads, mk consoles are a heavier duty alternative to angles. They are made of cast aluminum and milled square.



Nut 1 M12, Steel Zn 34.60.0301

SHCS DIN 6912, M12 x 30 D69121230

Ribbed Washer \varnothing 12, Spring Steel Zn K111010019

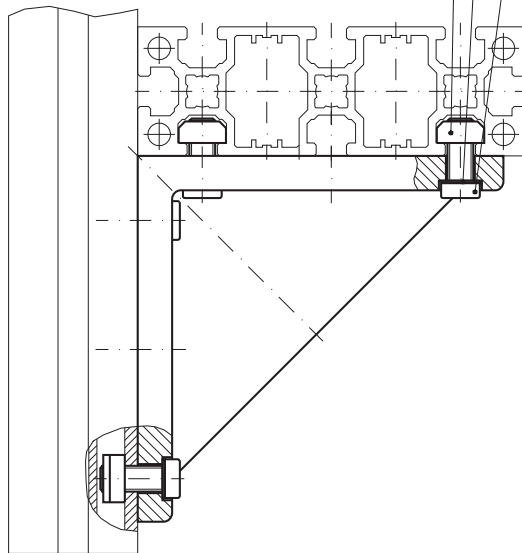

25 | 40 | 50 | 60

Console 60/1
31.60.0001

Cast alu

Weight 1.38 kg

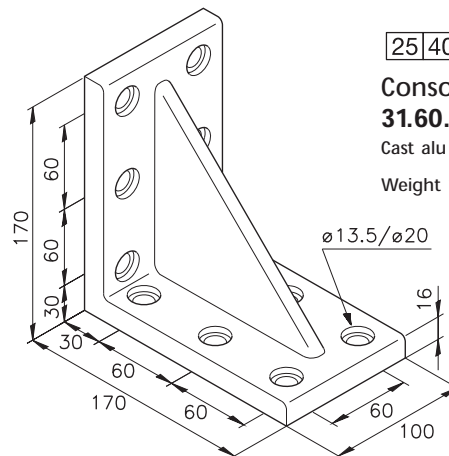

25 | 40 | 50 | 60

Console 60/7
31.60.0007

Cast alu

Weight 2.03 kg

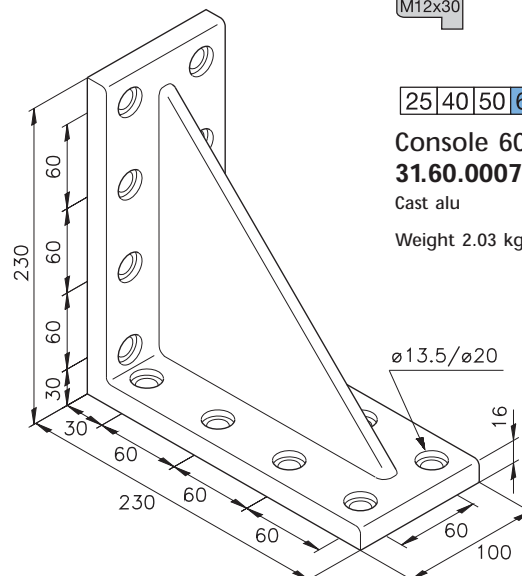

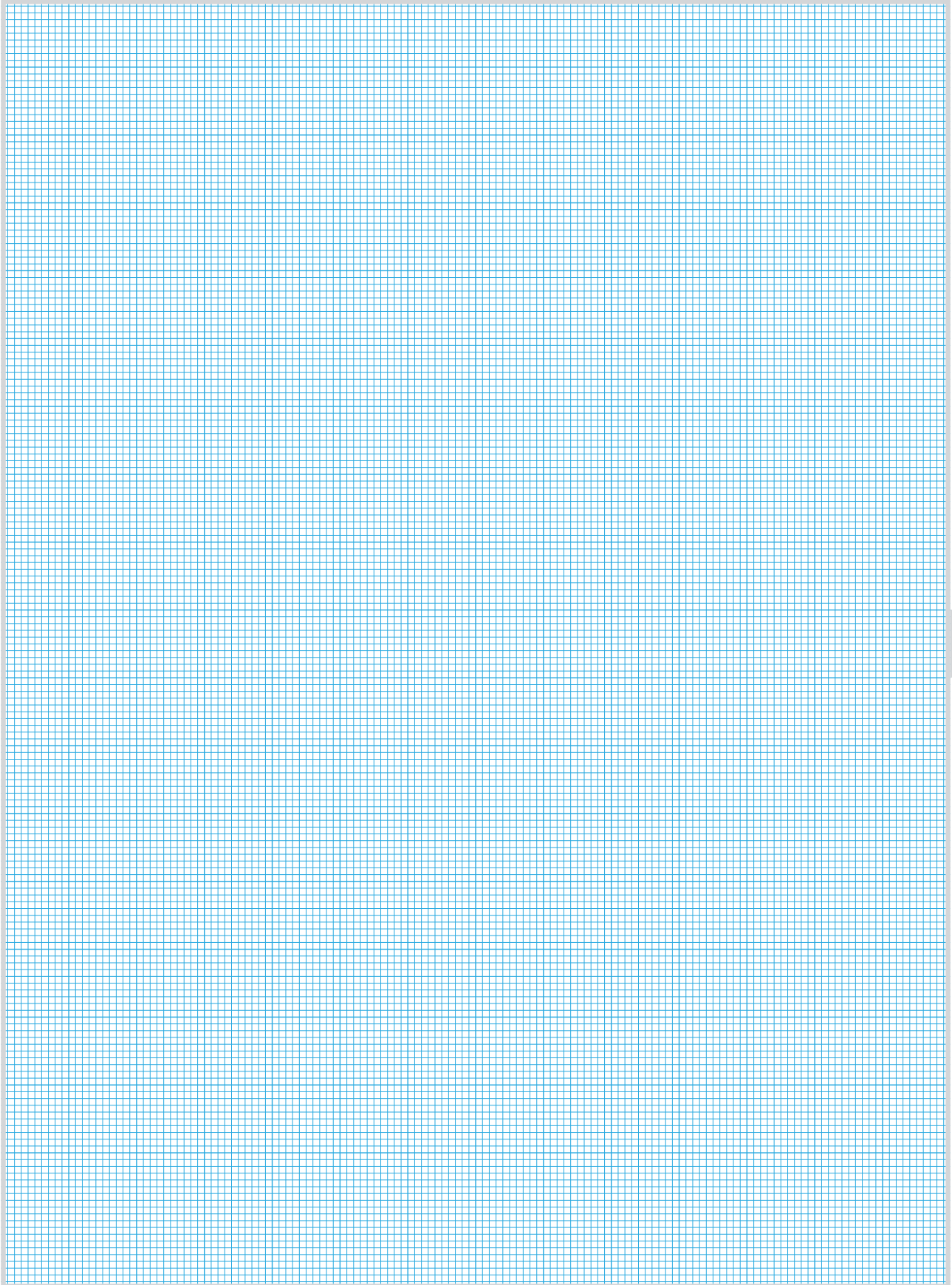

Assembly Components

Internal Fasteners

Tension plugs are an alternative to angles, if slots need to be kept free for inserting paneling or should structures need to be made without immediately visible connection elements. As a result, tension plugs are frequently used for guarding or in light-duty framing.

➤ Profile services see page 74

➤ Drill Fixtures see from page 226

Series 25

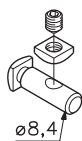
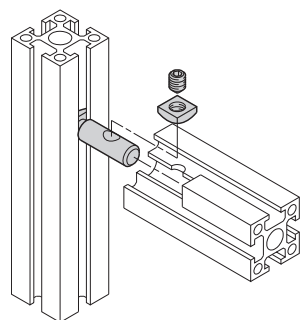

Tension Plug
Series 25
B51.03.009
Steel Zn

for end services BA, BB
(Drill \varnothing 5,8 mm access hole, 15 mm from end)

Series 40

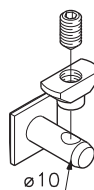
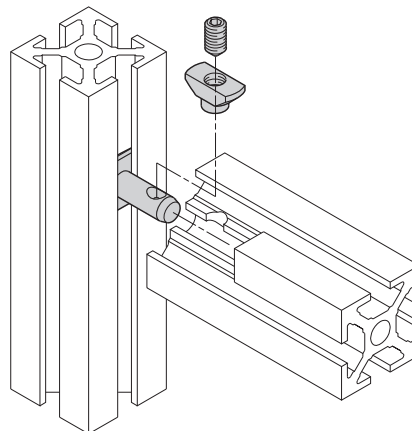

Tension Plug
Series 40
B51.03.004
Steel Zn
B51.03.030
Stainless Steel

for end services BA, BB
(Drill \varnothing 10 mm access hole, 15 mm from end)

Internal Fasteners



Series 40/1

The tension plug 40/1 is perfect for frame structures with paneling because all slots remain free. In addition, the T-shaped head of the tension plug allows for later installation of beams by passing through the top of the T-slot and rotating the beam 90°.

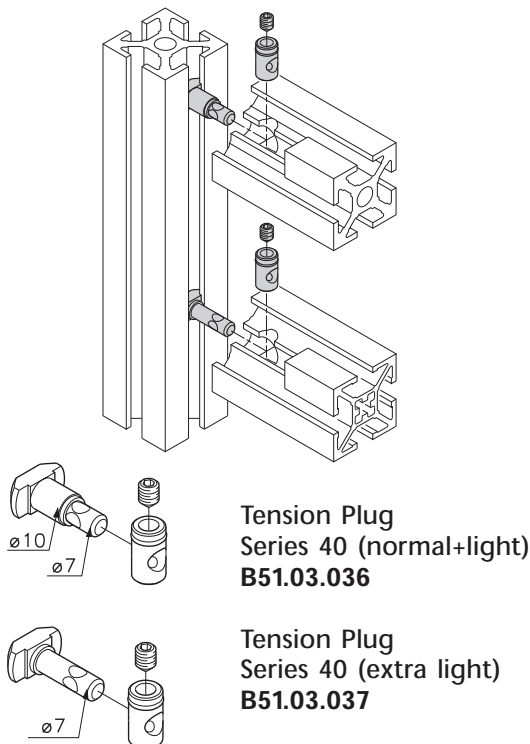

for end services BV oder BW
 (Drill ø 10 mm through hole, 15 mm from end)

➤ Drill Fixtures see from page 226

Series 40 light

The tension fastener 40 provides users with the option of setting up profile structures using assembly components consisting solely of standard hardware. This connection requires an M8 thread or threaded insert in the profile that is to be attached, and a ø 9 mm access hole at the connection position in the other profile.

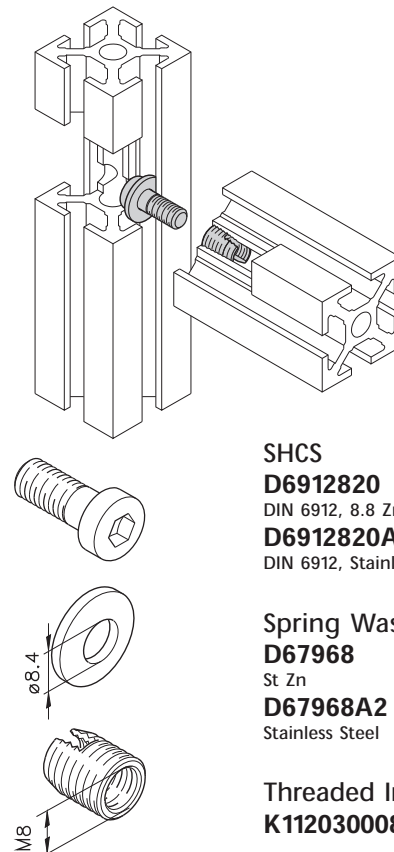

SHCS
D6912820
 DIN 6912, 8.8 Zn
D6912820A2
 DIN 6912, Stainless Steel

Spring Washer
D67968
 St Zn
D67968A2
 Stainless Steel

Threaded Insert M8
K112030008

Assembly Components

Internal Fasteners

Series 50

The tension plug 50 sets itself apart thanks to its high load-bearing capacity. A further advantage is the standard drill service. Only the profile with the tension plug is drilled. A profile prepared in this way can be inserted into another profile and mounted in any position required without additional work.

 Profile services see page 74

 Drill Fixtures see from page 226

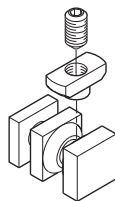
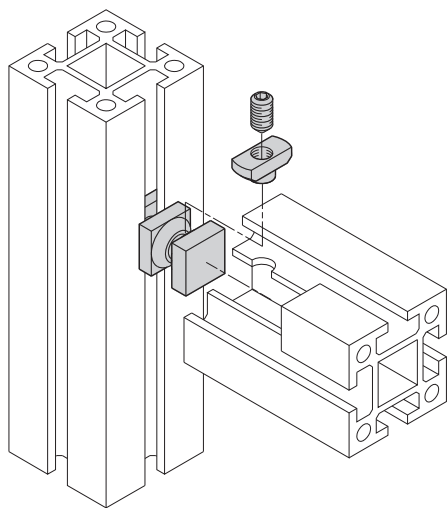

Tension Plug
for Series 50
B51.03.006

for end services BF, BG
(Drill \varnothing 10 mm access hole, 15 mm from end)

Internal Fasteners

Swivel Tension Plug

The swivel tension plug can be used to connect miter cut profiles. All angles between $\pm 90^\circ$ can be realized. The connection requires a one-sided $\varnothing 9$ resp. $\varnothing 10$ mm hole on the chamfered edge in both profiles at a center-distance of 15 mm to the middle of the cut edge.

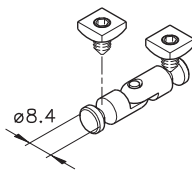

25 | 40 | 50 | 60

Swivel Tension Plug Series 25
B51.03.010
 Steel Zn
 90 - 270°

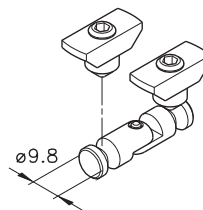

25 | 40 | 50 | 60

Swivel Tension Plug Series 40
B51.03.011
 Steel Zn, 90 - 270°

Swivel Tension Plug Series 25, Steel Zn, B51.03.010

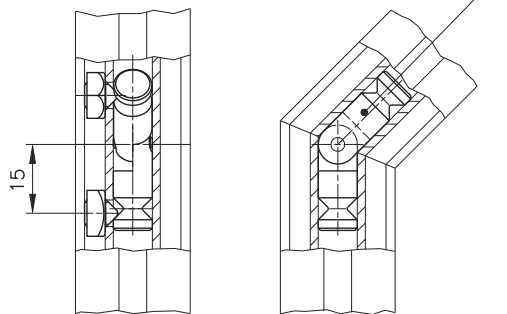

for series 25
 (Drill $\varnothing 9$ mm access hole, 15 mm from end)

Swivel Tension Plug Series 40, Steel Zn, B51.03.011

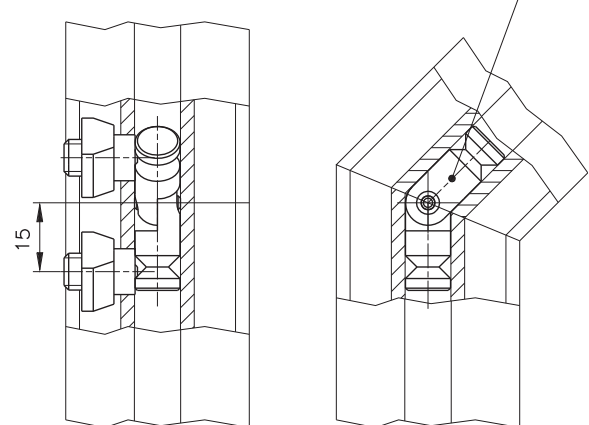

for series 40
 (Drill $\varnothing 10$ mm access hole, 15 mm from end)

Assembly Components

Plates

Face Plates



Connecting plates for assembly at profile ends

Face plates are primarily used to mount profiles into existing framing. The plates feature keyways to prevent twist, and the included hardware is designed for drop-in use.

Profile services see page 74



SHCS DIN 7984, M8 x 20, **D7984820**

Plate, **50.05.0090**

T-Nut M6, Stainless Steel, **34.07.0006**

SHCS M6 x 20, **D0912620**

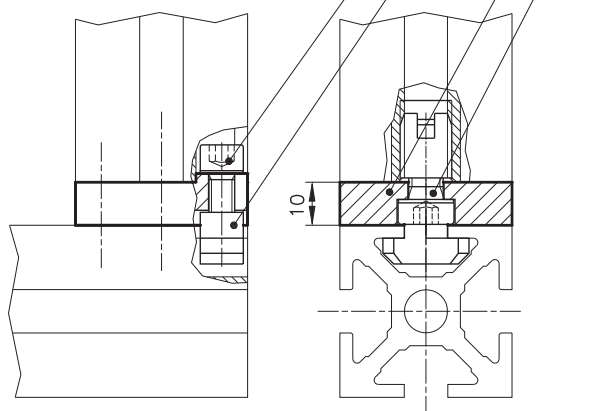

25 | 40 | 50 | 60

Face Plate 40
profile end
B46.07.090

Al tumbled

includes mounting hardware

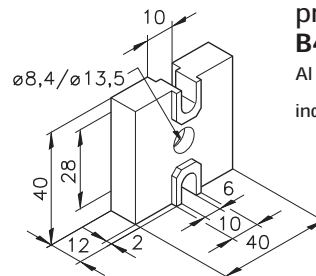

for end services 1 x thread M8

25 | 40 | 50 | 60

Face Plate 50
profile end
B46.07.095

Al tumbled,

for Profile mk 2000

includes mounting hardware

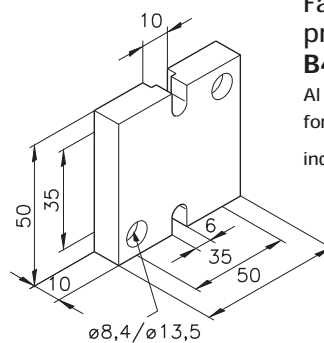

for end services 2 x/(4 x) thread M8

Plates

Light version

Series 25

The light plates are designed for low to medium loads, especially for additional stiffening of connections.

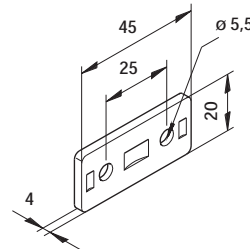
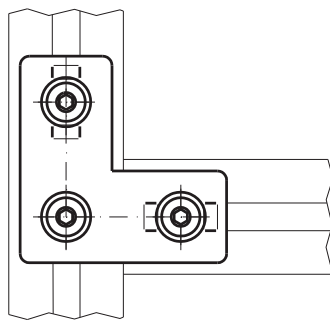
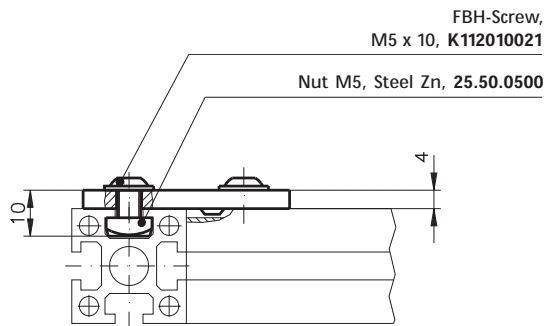

Flanged Button-Head

25 | 40 | 50 | 60

Straight Plate 01

25.50.3000

Al tumbled

T25.50.3000

includes mounting hardware

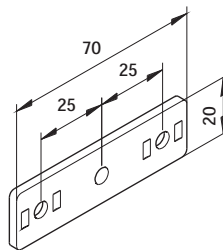

25 | 40 | 50 | 60

Straight Plate 02

25.50.3001

Al tumbled

T25.50.3001

includes mounting hardware

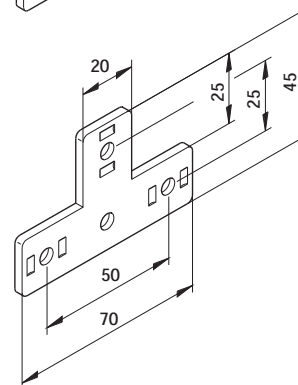

25 | 40 | 50 | 60

T-Platte 01

25.50.3006

Al tumbled

T25.50.3006

includes mounting hardware

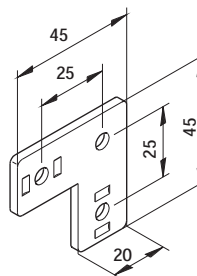

25 | 40 | 50 | 60

Angle Plate 01

25.50.3002

Al tumbled

T25.50.3002

includes mounting hardware

Assembly Components

Plates

Light version

Series 40 and 50

The light plates are designed for low to medium loads, especially for additional stiffening of connections.



Flanged Button-Head

25 40 50 60

Parallel Plate 05

50.05.0053

Al tumbled

T50.05.0053

includes mounting hardware

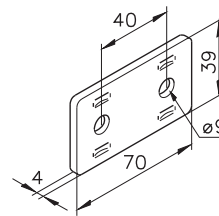

25 40 50 60

Parallel Plate 04

50.05.0077

Al tumbled

T50.05.0077

includes mounting hardware

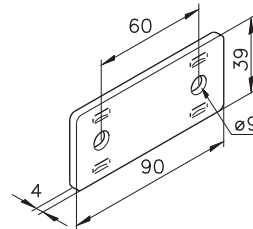

25 40 50 60

Parallel Plate 03

50.05.0052

Al tumbled

T50.05.0052

includes mounting hardware

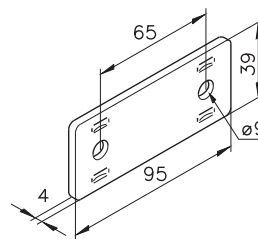

25 40 50 60

Parallel Plate 07

50.05.0047

Al tumbled

T50.05.0047

includes mounting hardware

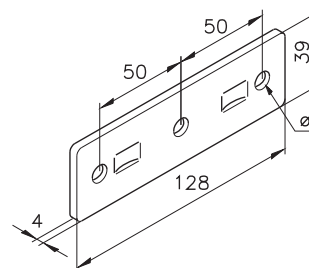

Nut 1 M8,
Steel Zn, 34.01.0001

FBH-Screw,
M8 x 12, K112010002

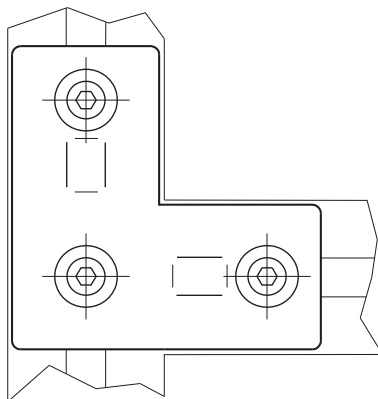
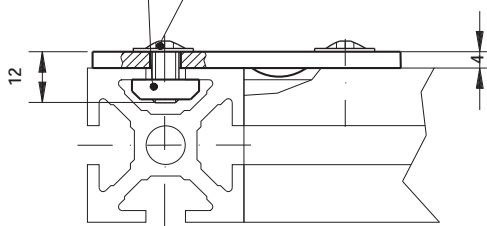

Plates

Light version *Series 40 and 50*

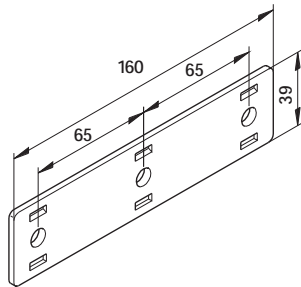

Flanged Button-Head

25 40 50 60

Parallel Plate 09
50.05.0070

Al tumbled

T50.05.0070

includes mounting hardware

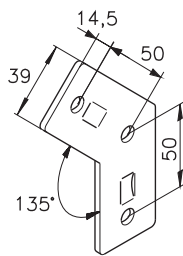

25 40 50 60

Angle Plate 13
50.05.0051

Al tumbled

T50.05.0051

includes mounting hardware

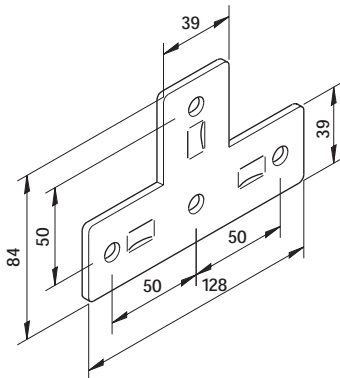

25 40 50 60

T-Plate 03
50.05.0046

Al tumbled

T50.05.0046

includes mounting hardware

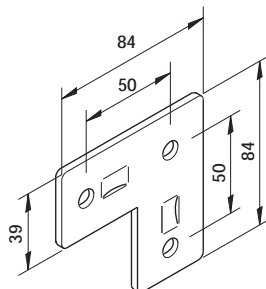

25 40 50 60

Angle Plate 03
50.05.0045

Al tumbled

T50.05.0045

includes mounting hardware

Assembly Components

Plates

Heavy duty version

Series 40

The heavy duty plates are designed for high loads. Plates with keyways ensure precisely aligned profiles.



M8 x 16

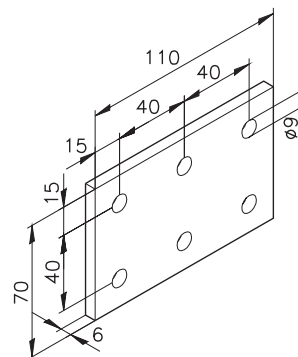

25 40 50 60

Plate 40/2
50.05.0060
Al tumbled

Ribbed Washer \varnothing 8,4, K111010017

Nut 2/50, M8, 34.01.0003

SHCS,
M8 x 16, D0912816

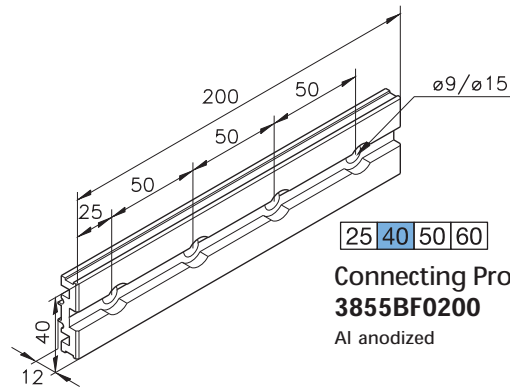
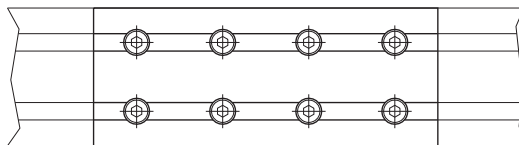
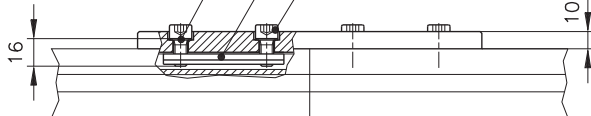

25 40 50 60

Connecting Profile 3855
3855BF0200
Al anodized

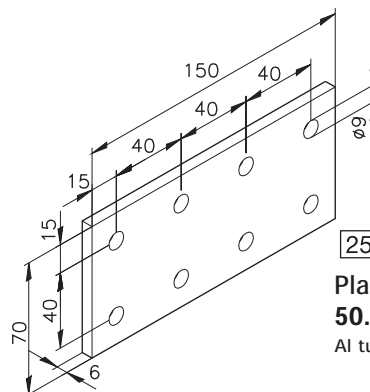

25 40 50 60

Plate 40/3
50.05.0061
Al tumbled

Plates

Heavy duty version *Series 40*

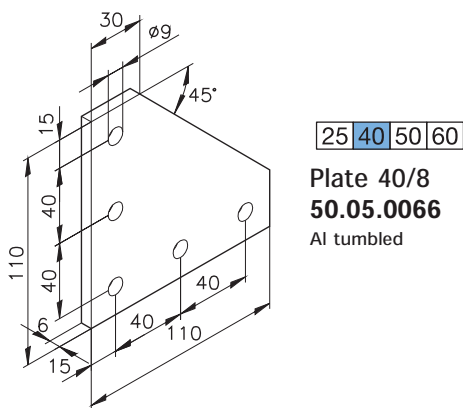
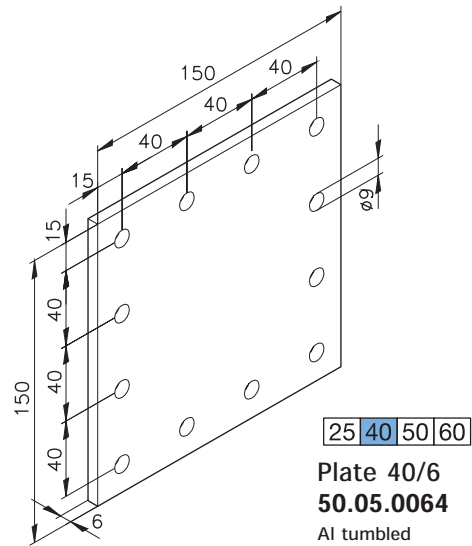
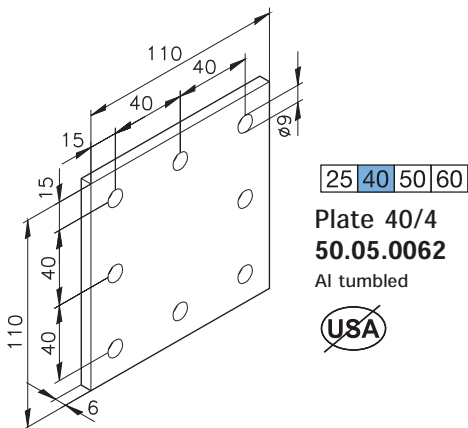
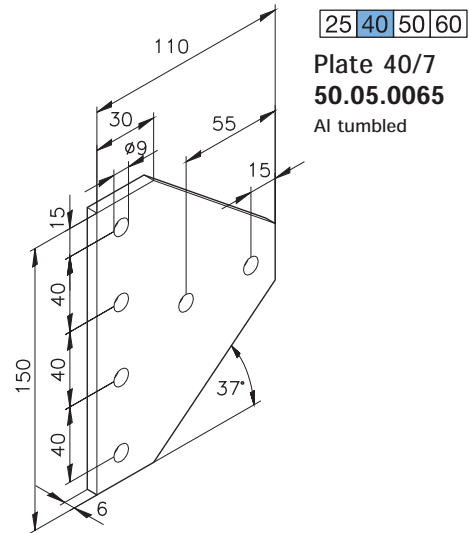
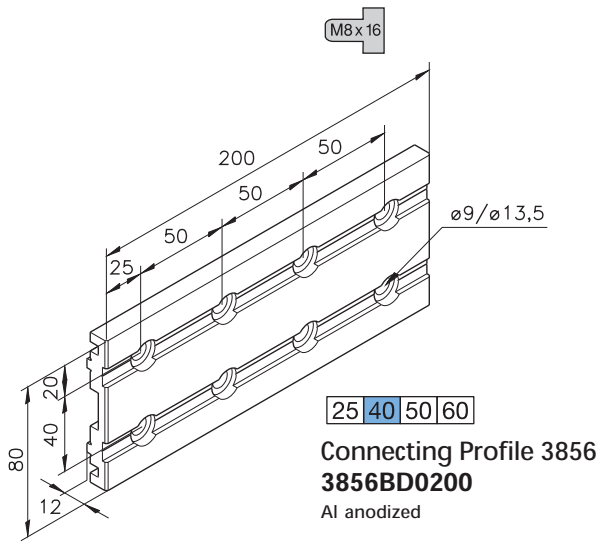



Assembly Components

Plates

Heavy duty version

Series 50

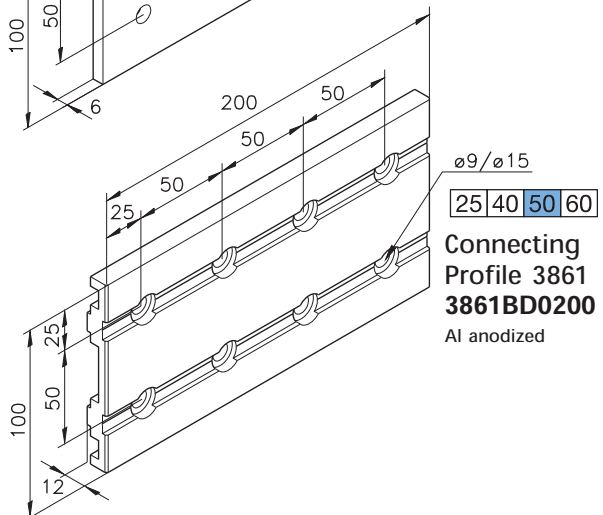
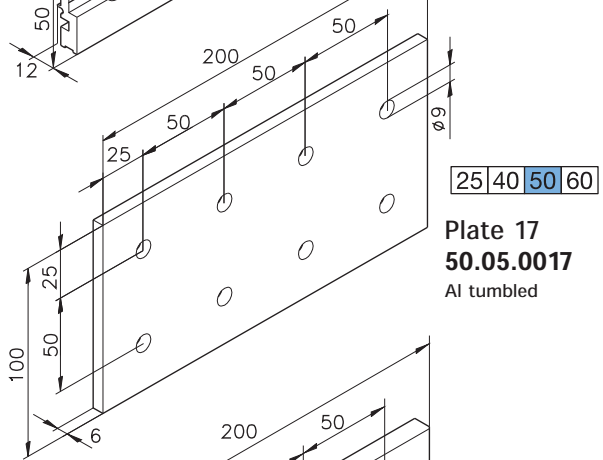
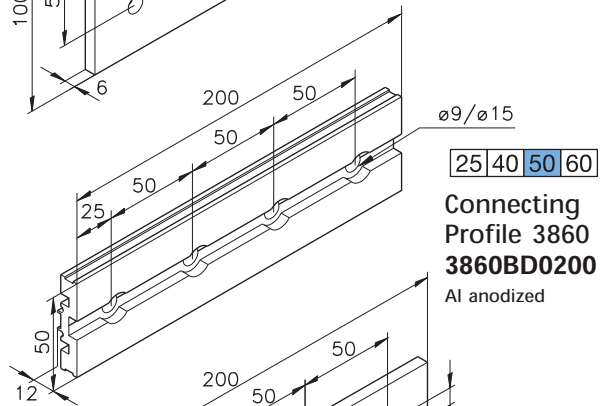
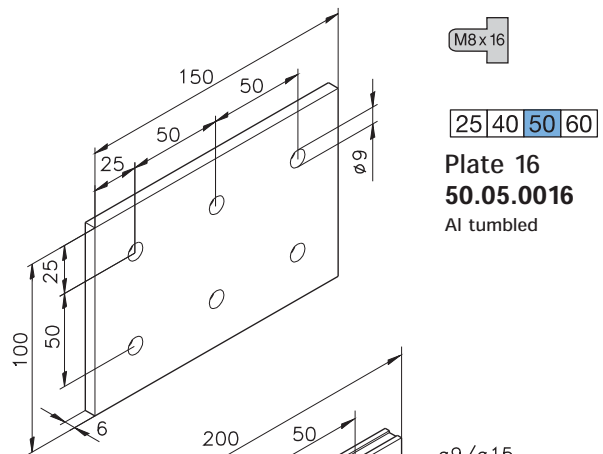
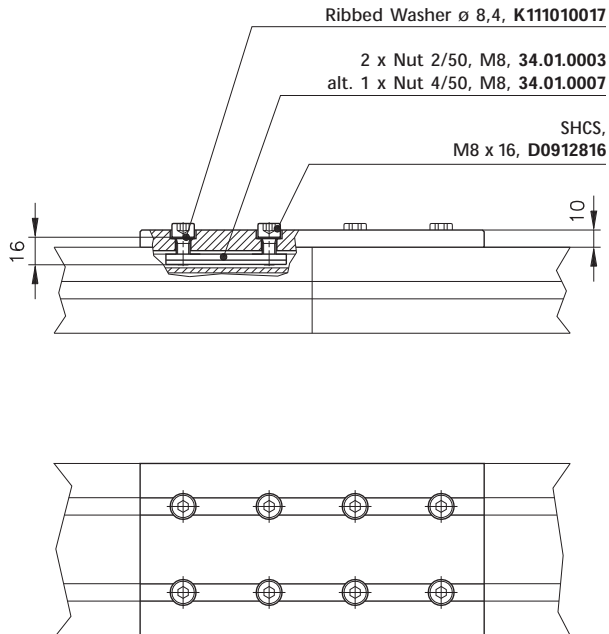

Plates

Heavy duty version *Series 50*

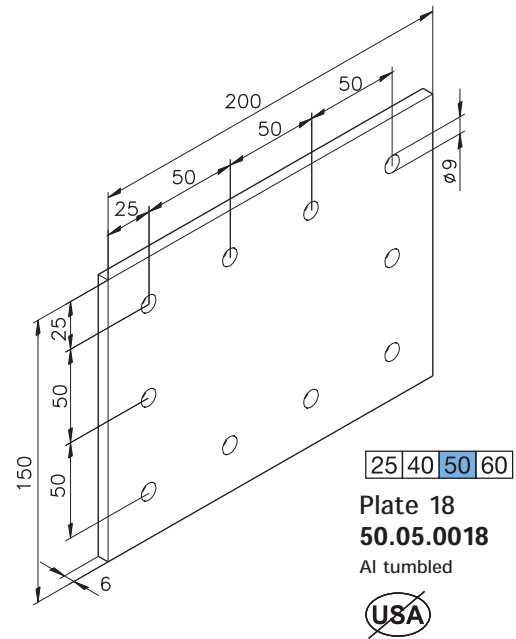
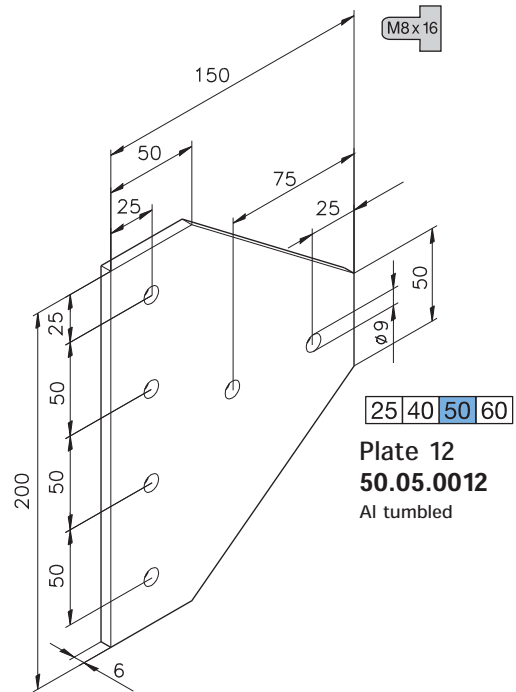
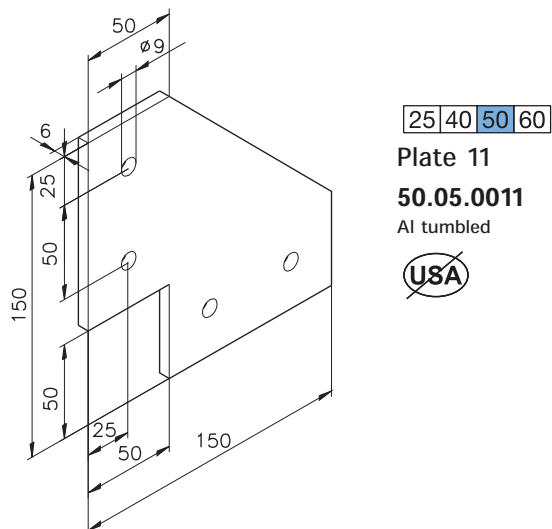
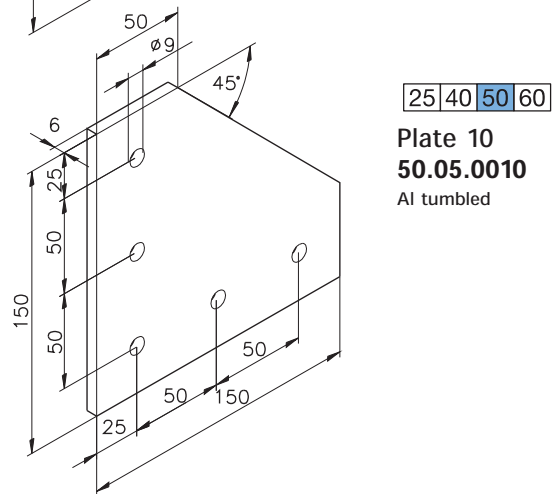
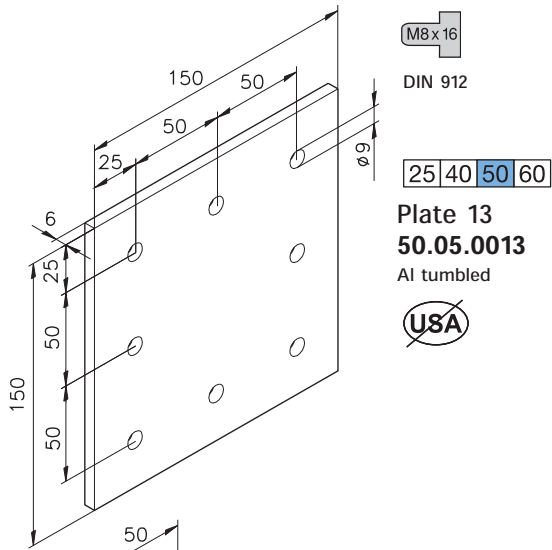



Assembly Components

Plates

Heavy duty version

Series 60

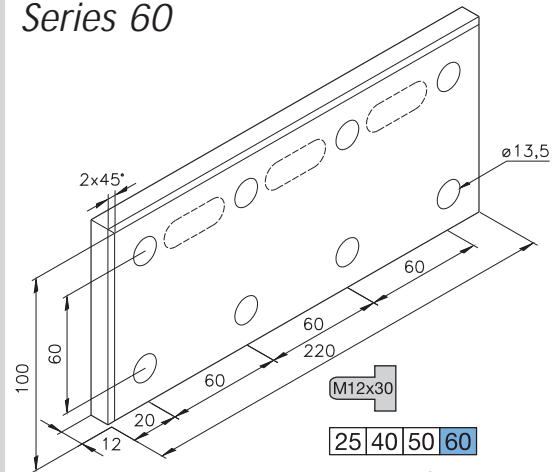

M12x30

25 | 40 | 50 | 60

Plate 60/26
50.05.6026

Al tumbled

with 14 mm slots for T-slot alignment.
Use with 14x9x40 mm Parallel Keys
(Ident Nr. D6885A14940)

M12x25

25 | 40 | 50 | 60

Plate 60/10
50.05.6010

Al tumbled

with 14 mm slots for T-slot alignment.
Use with 14x9x40 mm Parallel Keys
(Ident Nr. D6885A14940)

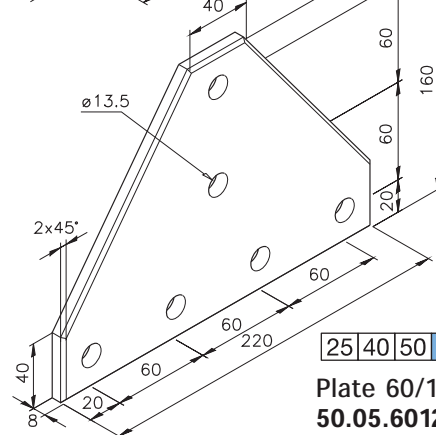
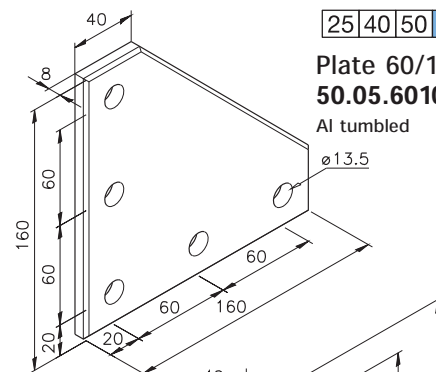

25 | 40 | 50 | 60

Plate 60/12
50.05.6012

Al tumbled

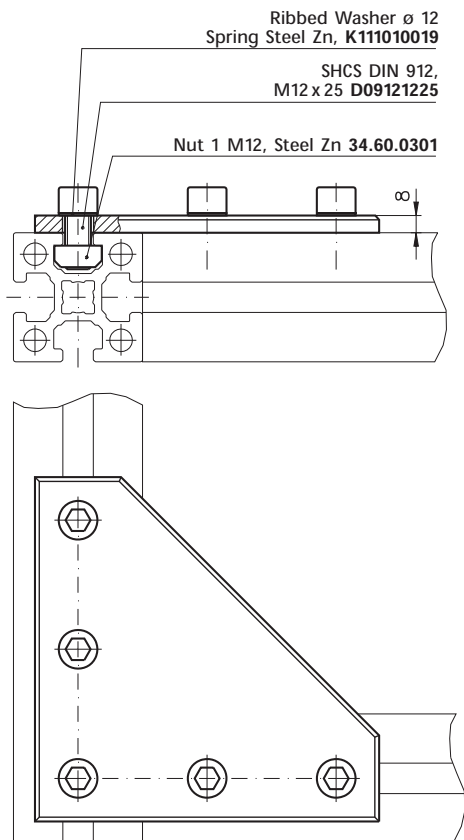

Corner Blocks

Series 25

mk corner blocks connect the ends of profiles to each other to form a corner connection. They ensure clean junctions which visually enhance your design. Corner blocks using screws for attachment leave the full T-slots available. These attractive components are ideal for displays, furniture, guarding.



Open Connection

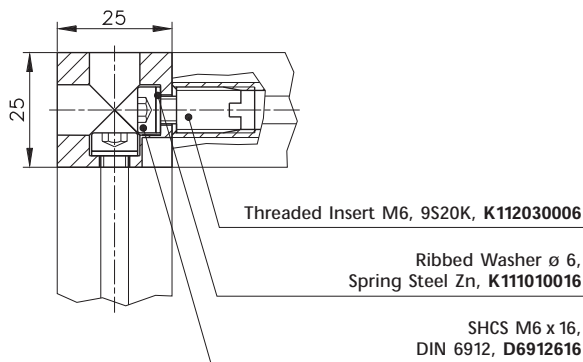

Closed Connection

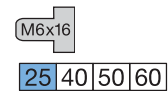
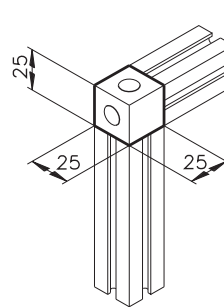
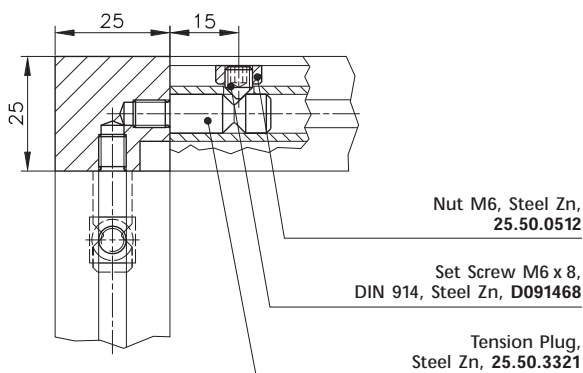

Corner Block 25 25.50.3300

Al tumbled
 connects for ex.
 2 x Profile mk 2025.01
 hardware ordered separately

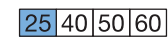
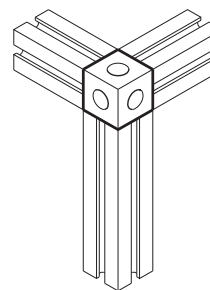

Corner Block 26 25.50.3301

Al tumbled
 connects for ex.
 3 x Profile mk 2025.01
 hardware ordered separately

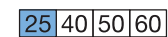
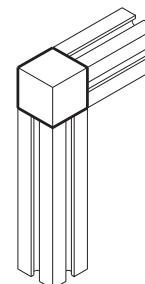

Corner Block 30 B46.05.001

Al tumbled
 connects for ex.
 2 x Profile mk 2025.01
 includes all hardware

Assembly Components

Corner Blocks

Series 25

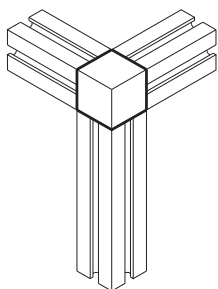

25 40 50 60

Corner Block 31 B46.05.002

Al tumbled

connects for ex.
3 x Profile mk 2025.01
includes all hardware

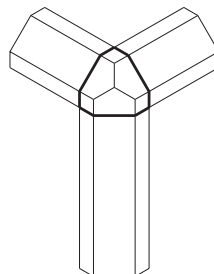

25 40 50 60

Corner Block 35 B46.05.006

Al tumbled

connects for ex.
3 x Profile mk 2025.38
includes all hardware

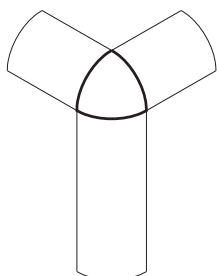

25 40 50 60

Corner Block 32 B46.05.003

Al tumbled

connects for ex.
3 x Profile mk 2025.37
includes all hardware

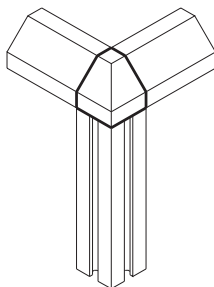

25 40 50 60

Corner Block 36 B46.05.007

Al tumbled

connects for ex.
1 x Profile mk 2025.01
2 x Profile mk 2025.38
includes all hardware

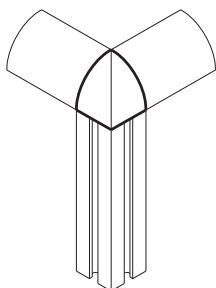

25 40 50 60

Corner Block 33 B46.05.004

Al tumbled

connects for ex.
1 x Profile mk 2025.01
2 x Profile mk 2025.37
includes all hardware

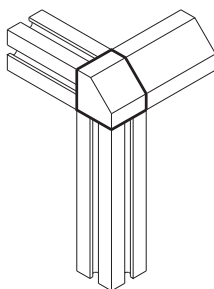

25 40 50 60

Corner Block 37 B46.05.008

Al tumbled

connects for ex.
2 x Profile mk 2025.01
1 x Profile mk 2025.38
includes all hardware

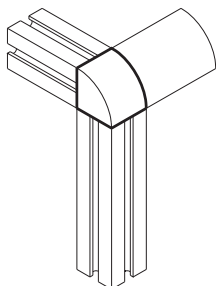

25 40 50 60

Corner Block 34 B46.05.005

Al tumbled

connects for ex.
2 x Profile mk 2025.01
1 x Profile mk 2025.37
includes all hardware

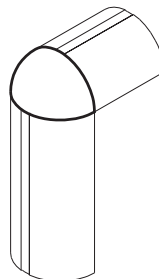

25 40 50 60

Corner Block 38 B46.05.009

Al tumbled

connects for ex.
2 x Profile mk 2025.39
includes all hardware

Corner Blocks

Series 40

mk corner blocks connect the ends of profiles to each other to form a corner connection. They ensure clean junctions which visually enhance your design. Corner blocks using screws for attachment leave the full T-slots available. These attractive components are ideal for displays, furniture, guarding.

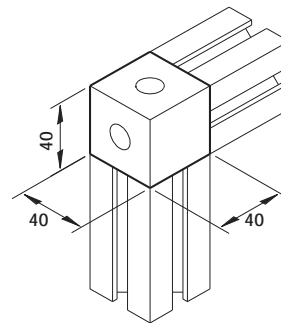

M8x20

25 40 50 60

Corner Block 6
79.01.0006

Al tumbled

connects for ex.

2 x Profile mk 2040.01

hardware ordered separately

Open Connection

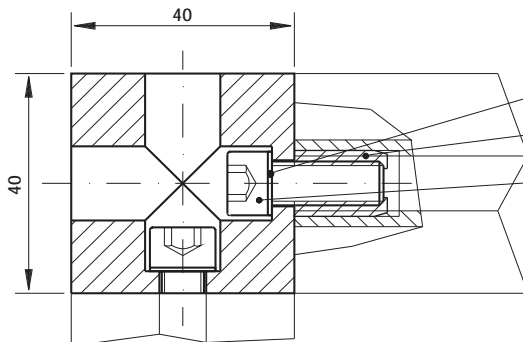

Ribbed Washer ϕ 8.4, Spring Steel Zn, K111010017

Threaded Insert M8, 9S20K, K112030008

SHCS M8 x 20, DIN 912, D0912820

Closed Connection

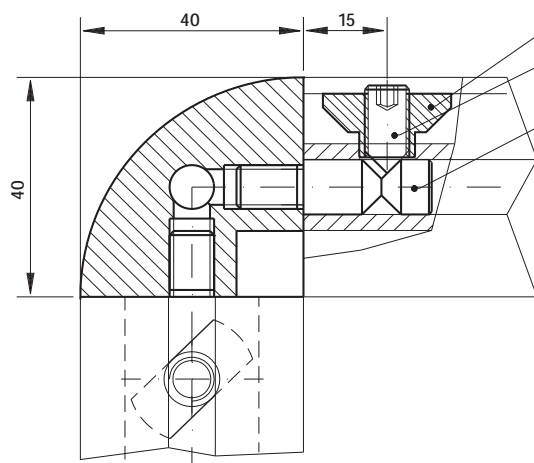

Nut M8, Steel Zn, 34.06.0003

Set Screw M8 x 16, DIN 914, Steel Zn, D0914816

Tension Plug, Steel Zn, 05.03.0004

Tools required:
 Drill ϕ 10 mm
 see tools section pg. 224

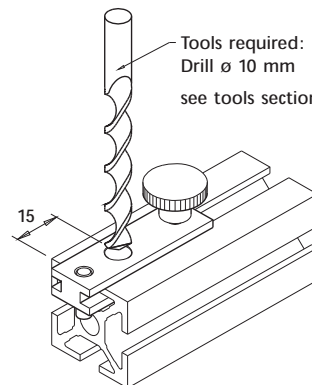

Drill Fixture
B51.03.005
 C45K

Assembly Components

Corner Blocks

Series 40

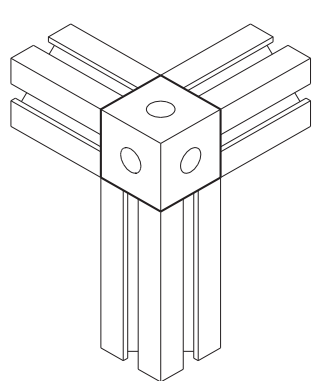

M8x20

25 40 50 60

Corner Block 5 79.01.0005

Al tumbled
connects for ex.
3 x Profile mk 2040.01
hardware ordered separately

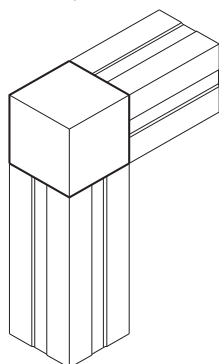

25 40 50 60

Corner Block 40 B46.05.041

with Nut, Tension Plug
and Set Screw
Al tumbled
connects for ex.
2 x Profile mk 2040.11
includes all hardware

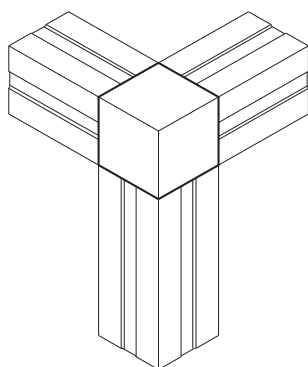

25 40 50 60

Corner Block 39 B46.05.040

with Nut, Tension Plug
and Set Screw
Al tumbled
connects
3 x Profile mk 2040.11
includes all hardware

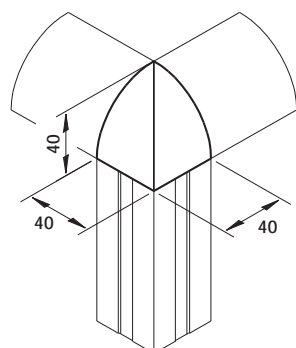

25 40 50 60

Corner Block 42 B46.05.043

with Nut, Tension Plug
and Set Screw
Al tumbled
connects for ex.
2 x Profile mk 2040.15
1 x Profile mk 2040.01
includes all hardware

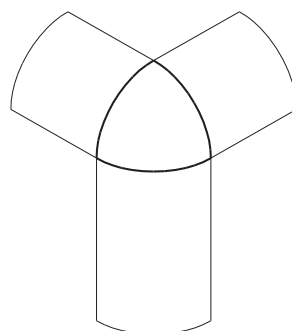

25 40 50 60

Corner Block 41 B46.05.042

with Nut, Tension Plug
and Set Screw
Al tumbled
connects
3 x Profile mk 2040.15
includes all hardware

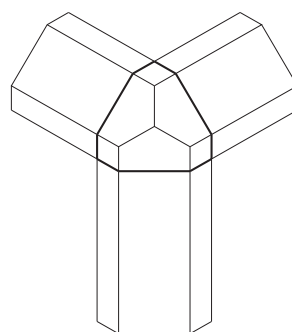

25 40 50 60

Corner Block 43 B46.05.044

with Nut, Tension Plug
and Set Screw
Al tumbled
connects
3 x Profile mk 2040.14
includes all hardware

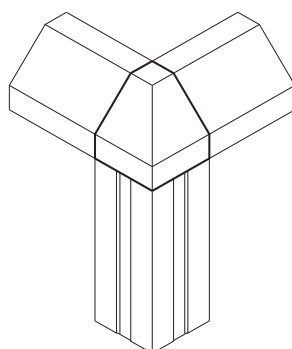

25 40 50 60

Corner Block 44 B46.05.045

with Nut, Tension Plug
and Set Screw
Al tumbled
connects for ex.
2 x Profile mk 2040.14
1 x Profile mk 2040.01
includes all hardware

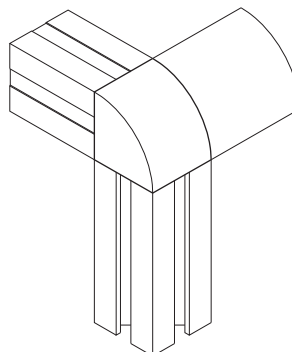

25 40 50 60

Corner Block 46 B46.05.039

with Nut, Tension Plug
and Set Screw
Al tumbled
connects for ex.
2 x Profile mk 2040.11
1 x Profile mk 2040.15
includes all hardware



Corner Blocks

Series 40

In combination with profiles mk 2040.18/19/20 the angles blocks ensure an aesthetically high quality connection. With the 120°, 135° and 150° angles even complex frames are realizable.

For further information see page 41

Set Screw M8 x 16,
 DIN 914, Steel Zn, **D0914816**

Nut M8, Steel Zn, **34.06.0003**

Tension Plug, Steel Zn, **05.03.0004**

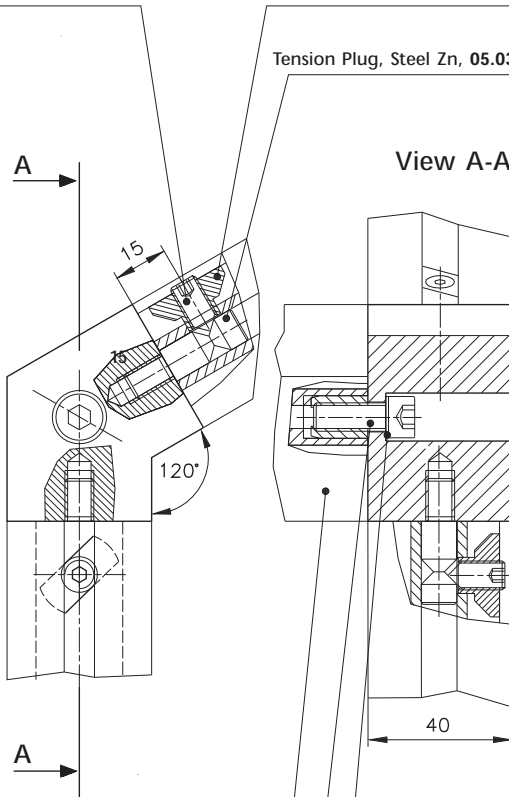

Profile 40x40 mit End Services 1xM8

SHCS M8 x 20,
 DIN 912, **D0912820**

Ribbed Washer \varnothing 8,4, **K111010017**

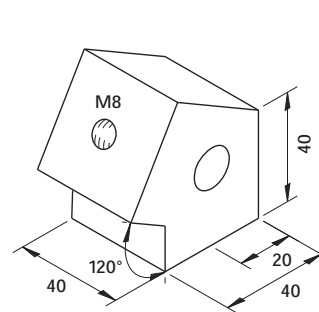

M8x20

25 40 50 60

Corner Block 47
B46.05.047

for Profile mk 2040.18
 includes mounting hardware

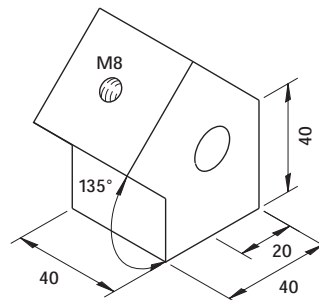

25 40 50 60

Corner Block 48
B46.05.048

for Profile mk 2040.19
 includes mounting hardware

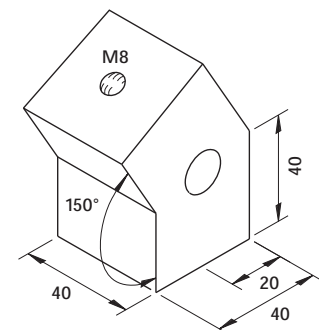

25 40 50 60

Corner Block 49
B46.05.049

for Profile mk 2040.20
 includes mounting hardware

Assembly Components

Angle Blocks

Series 40

These Angle Blocks were designed especially to strengthen machine frames and bases, or any construction requiring lateral stiffness of the profiles. Advantages include the elimination of angled profile cuts, as well as a key which fits firmly into the profile T-slots, preventing rotation. 30°, 45° and 60° Angle Blocks are standard.

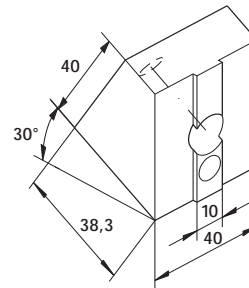

25 40 50 60

Angle Block 30°
79.01.0062

Al tumbled

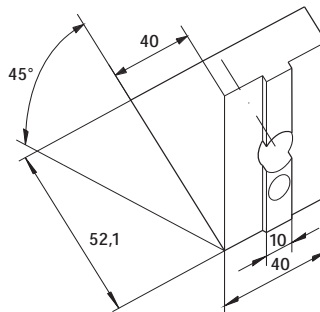
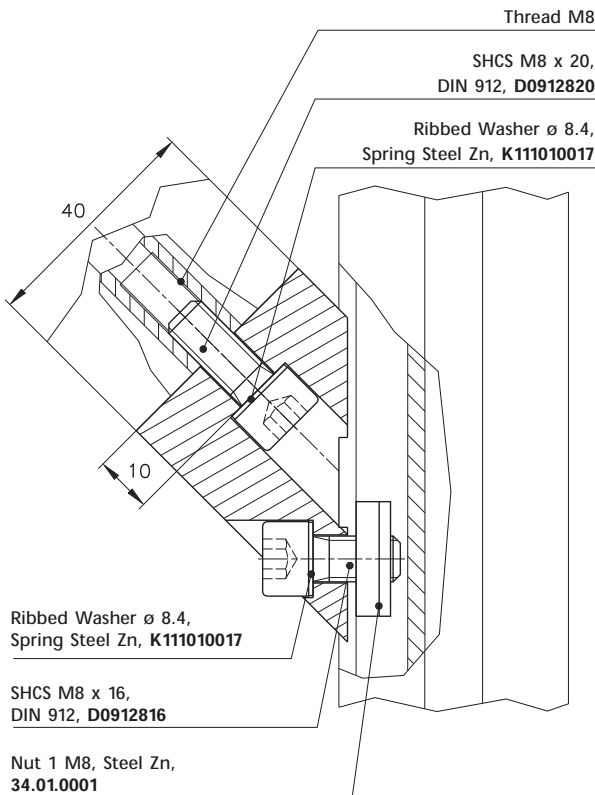

25 40 50 60

Angle Block 45°
79.01.0066

Al tumbled

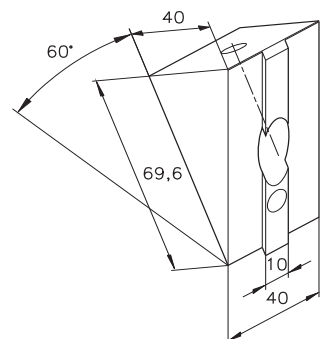

25 40 50 60

Angle Block 60°
79.01.0068

Al tumbled



Corner Blocks

Series 50

mk corner blocks connect the ends of profiles to each other to form a corner connection. They ensure clean junctions which visually enhance your design.

Assembly:

- When connecting using the mk 2000 profile, plug 5 must be inserted in the profile and screwed into place.
- An M8 thread must be cut in the center hole of the mk 2003 profile.

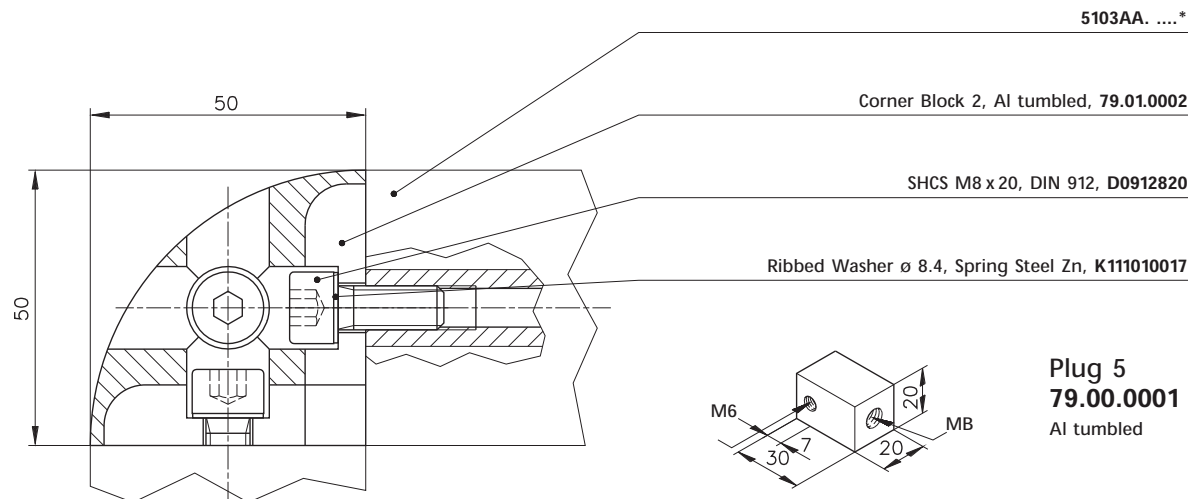
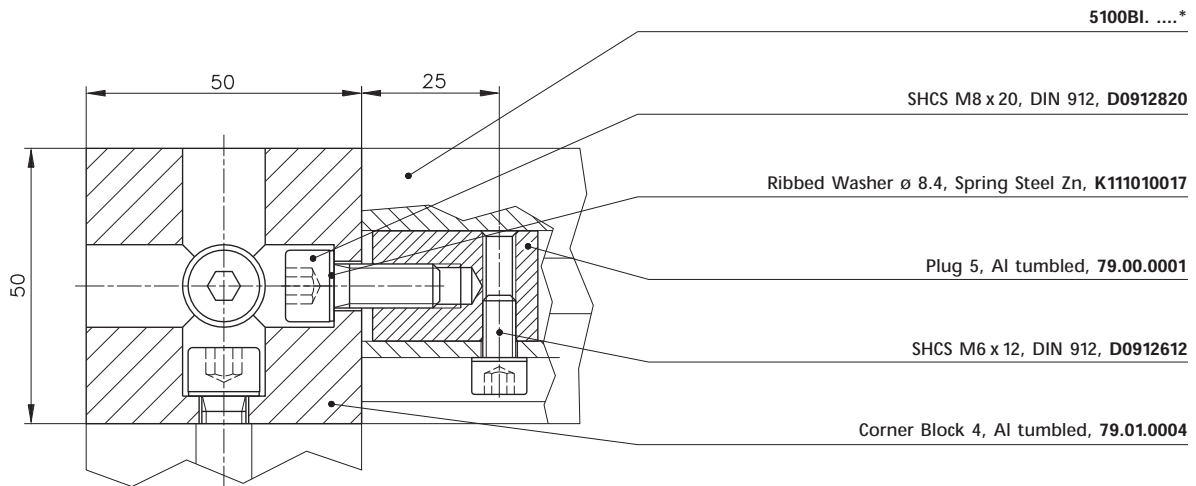

Plug 5
79.00.0001
 Al tumbled

Assembly Components

Corner Blocks

Series 50

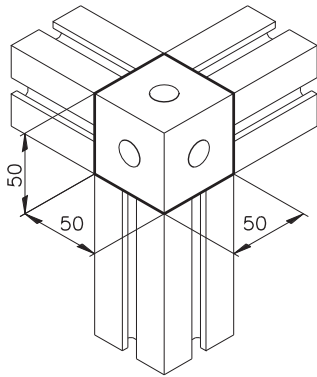

25 | 40 | 50 | 60

Corner Block 4
79.01.0004

Al tumbled
connects for ex.
3 x Profile mk 2000
hardware
ordered separately

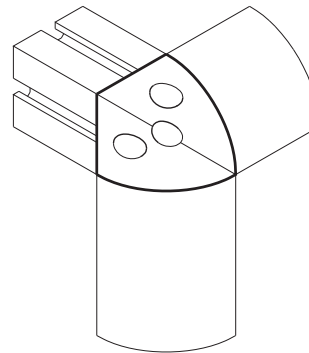

25 | 40 | 50 | 60

Corner Block 2
79.01.0002

Al tumbled
connects for ex.
1 x Profile mk 2000
2 x Profile mk 2003
hardware
ordered separately

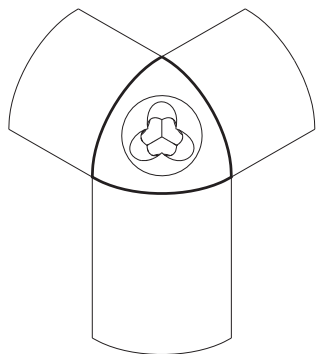

25 | 40 | 50 | 60

Corner Block 1
79.01.0001

Al tumbled
connects
3 x Profile mk 2003
B51.03.003
with End Cap
hardware
ordered separately

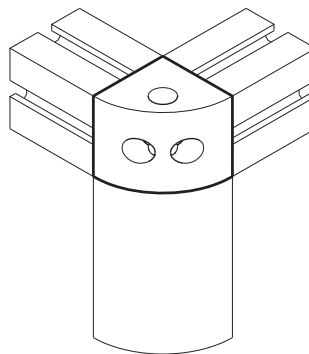

25 | 40 | 50 | 60

Corner Block 3
79.01.0003

Al tumbled
connects for ex.
2 x Profile mk 2000
1 x Profile mk 2003
hardware
ordered separately



Corner Blocks

Profile Wedges

mk profile wedges are used to make supporting structures with any required height and with various profile combinations. Depending on which profiles are selected, large spans can be crossed or large loads carried. Possible uses are, i.e. for building linear axis gantries, as well as in exhibition stand construction. Provide us with a description of your application, and we will supply the appropriate truss with the corresponding calculations. Further information is available on request.

Lattice

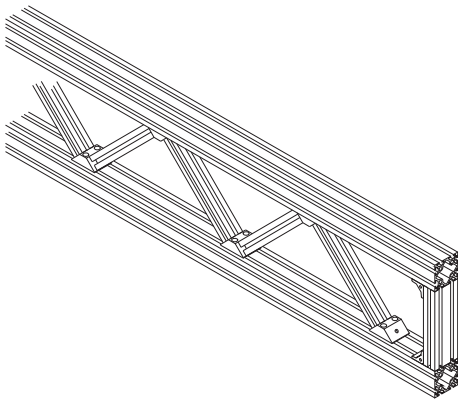

Box Lattice

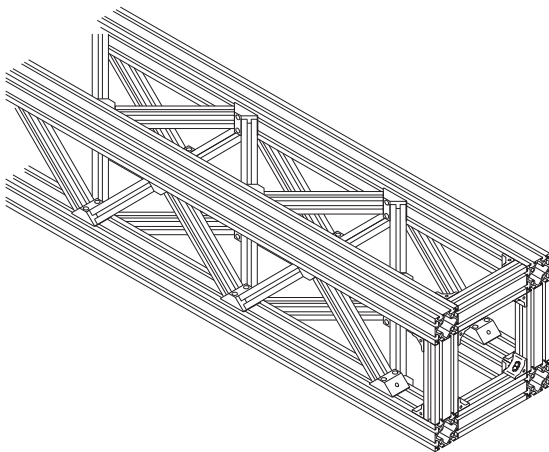

Example:

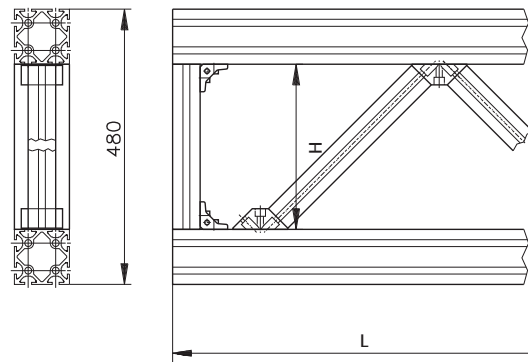

Upper and lower runner mk 2040.03
Brace profile mk 2040.01

I_x 31,185.00 cm⁴
I_y 643.00 cm⁴
W_x 705.00 cm³
W_y 87.00 cm³

Brace length = $\sqrt{2} \cdot (H-31.7)$ with 40-series brace
 = $\sqrt{2} \cdot (H-22.3)$ with 25-series brace

Assembly Components

Corner Blocks

Profile Wedges

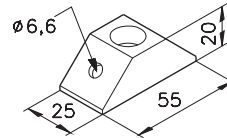
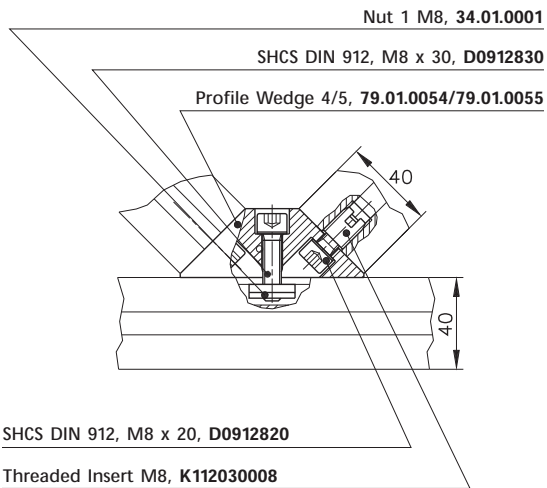
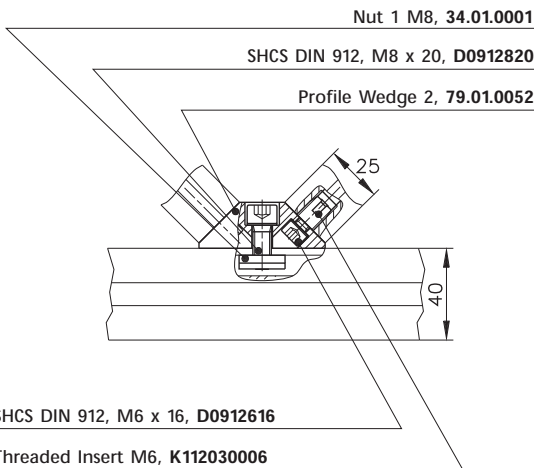

Profile Wedge 2
 for 2x mk 2025.01
 on series 40 and 50
79.01.0052
 Al tumbled

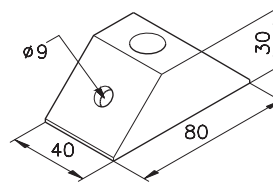

Profile Wedge 4
 for 2x mk 2040.01
 on series 40 and 50
79.01.0054
 Al tumbled

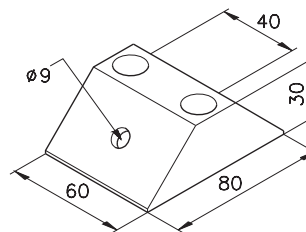

Profile Wedge 5
 for 2x mk 2040.01
 on series 40
79.01.0055
 Al tumbled

Angle Braces

mk Braces offer the ability to easily add stiffness to a heavily loaded profile frame. Using slot nuts makes later installation effortless.

Stock lengths 200, 300, 400 and 500 mm.

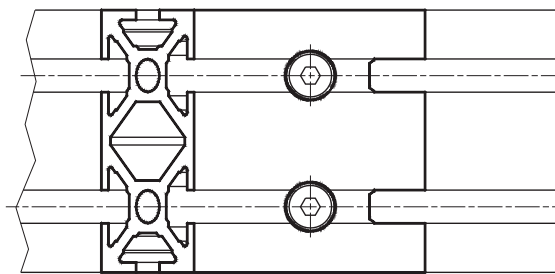

Nut 1 M8, Steel Zn, 34.01.0001

Ribbed Washer \varnothing 8.4,
Spring Steel Zn, K111010017

SHCS M8 x 20,
DIN 912, D0912820

mk 2040.02, 5402CA*

mk 2040.02

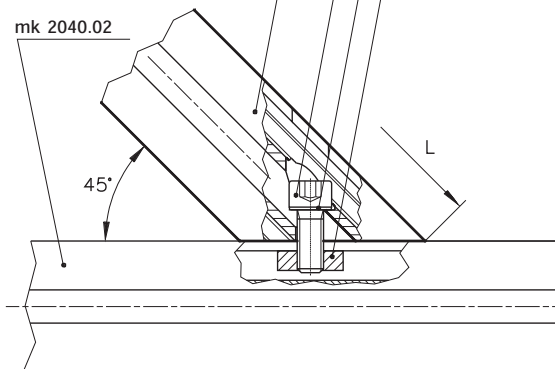

Angle Brace 01
(mk 2040.01)

5401CC*

AlMgSi 0,5 F25

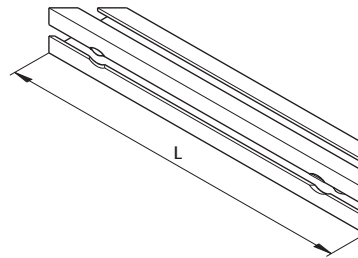

Angle Brace 40
(mk 2040.40)

5440CC*

AlMgSi 0,5 F25

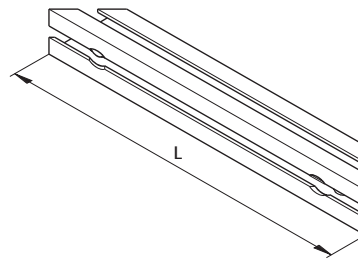

Angle Brace 02
(mk 2040.02)

5402CA*

AlMgSi 0,5 F25

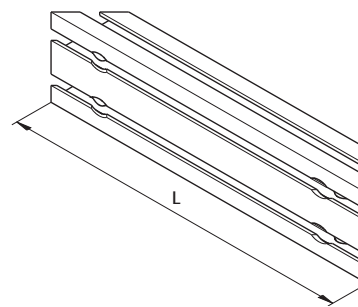

Assembly Components

Parallel Connectors

Parallel connectors establish a permanent connection between two profiles. When using Series 40 or 50 parallel connectors, the profiles can be released from each other at any time.

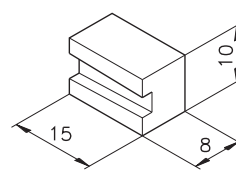

25 40 50 60

Parallel Connector
Series 25

25.50.3330

AlCuMgPb

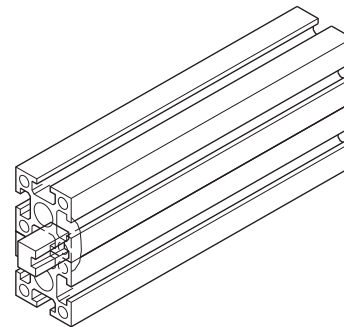

25 40 50 60

Parallel Connector

Series 40 **B51.03.017**

Series 50 **B51.03.016**

Series 40/50 **B51.03.018**

Al tumbled

Screw and Nut Steel, ZN

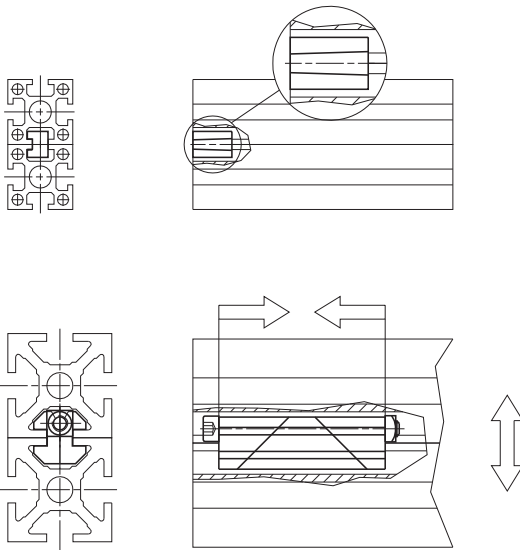
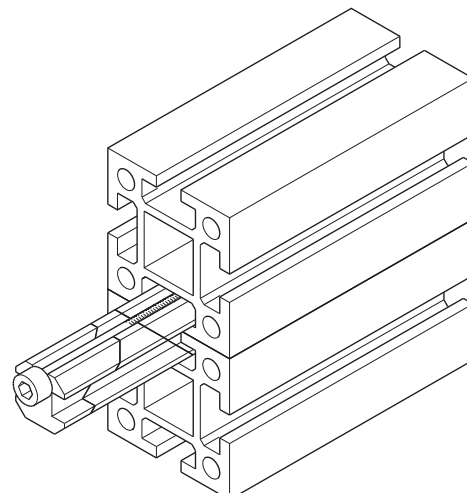
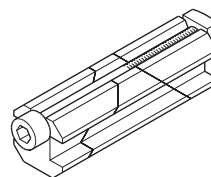

Tension causes the individual components of the connectors to push against the diagonal and clamp the profiles together. Parallel Connector 40/50 connects a series 40 profile to a series 50 profile.

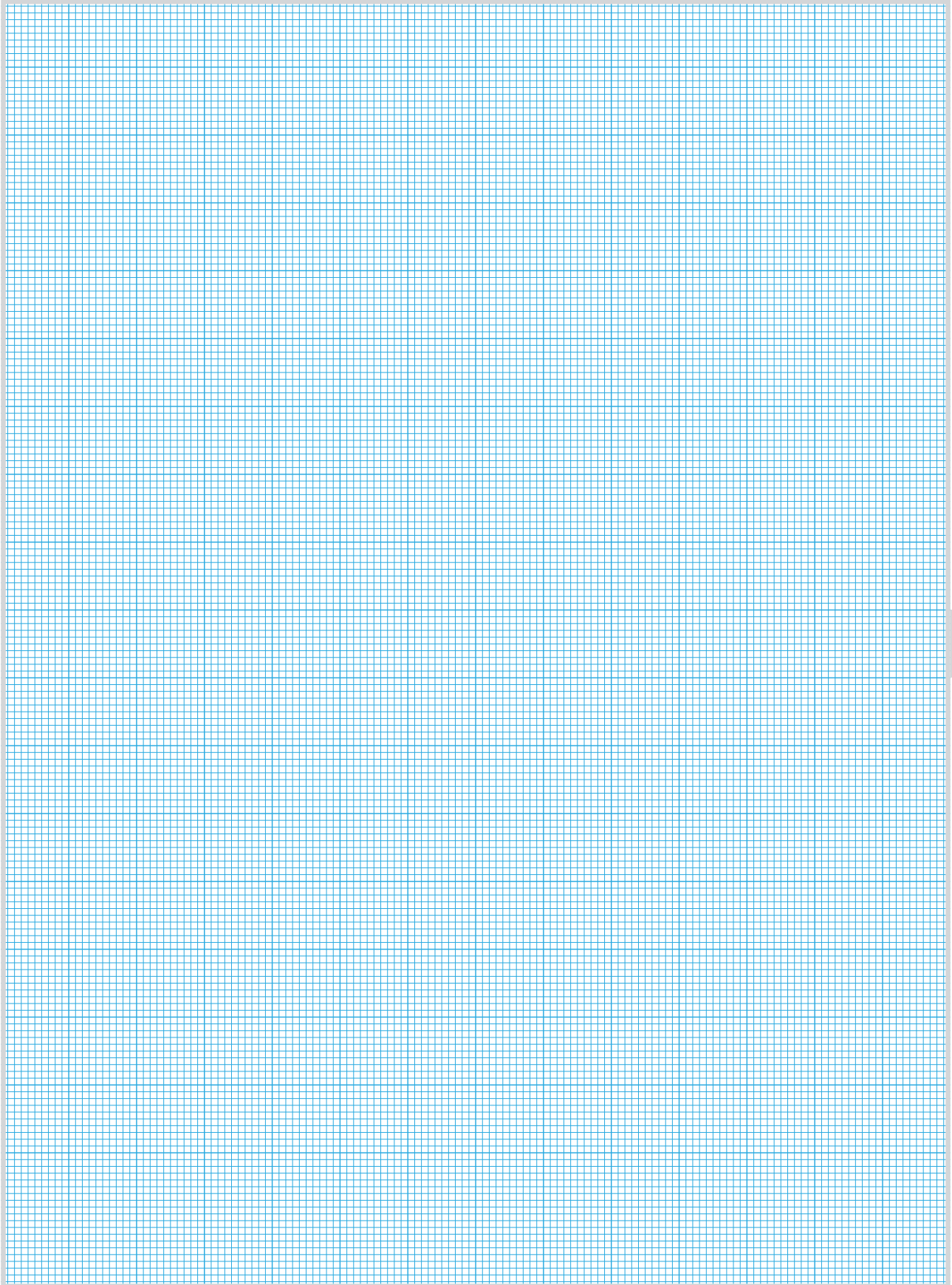

Assembly Components

Clamps

Clamps

mk clamps without key steps enable profiles to be quickly and securely assembled together at any angle relative to each other. Clamps with key steps ensure right-angled orientation of the profiles. Arranging two clamps opposite each other effectively prevents the profiles from twisting.

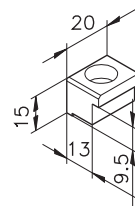
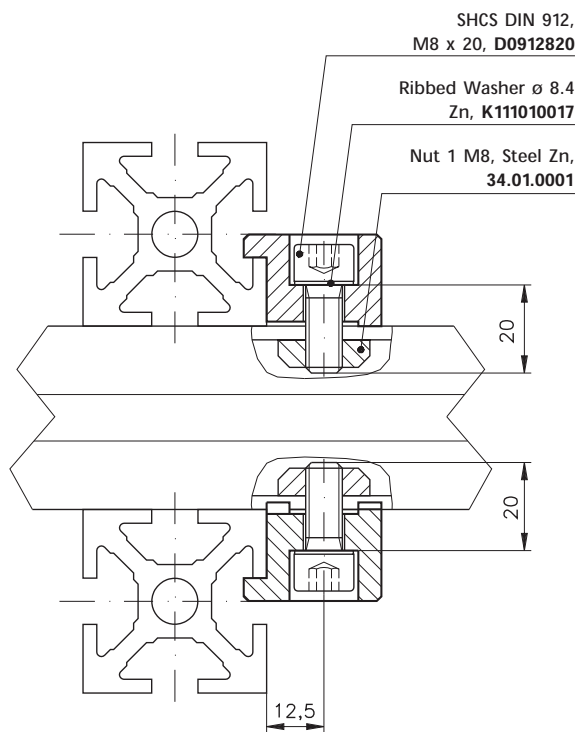

25 40 50 60

Clamp 25/0
25.50.7000

Al F28 tumbled

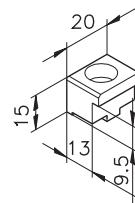

25 40 50 60

Clamp 25/1
25.50.7001

Al F28 tumbled,
Key width 6 mm

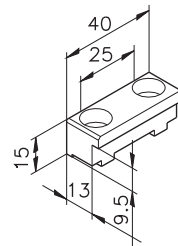

25 40 50 60

Clamp 25/2
25.50.7002

Al F28 tumbled,
Key width 6 mm

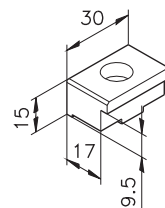

25 40 50 60

Clamp 40/25
30.00.0048

Al F28 tumbled,
Key width 10 mm

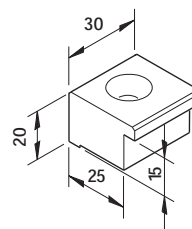

25 40 50 60

Clamp 5/30
30.00.0033

Al F28 tumbled

Clamps

Clamps

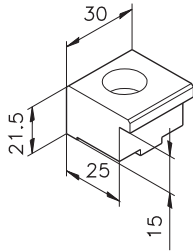

25 | 40 | 50 | 60

Clamp 6/30
30.00.0035
 Al F28 tumbled,
 Key width 10 mm

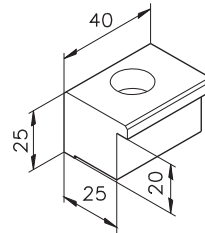

25 | 40 | 50 | 60

Clamp 1/40
30.00.0027
 Al F28 tumbled

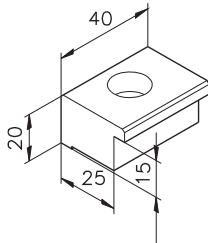

25 | 40 | 50 | 60

Clamp 5/40
30.00.0034
 Al F28 tumbled

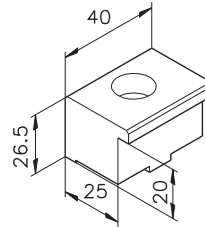

25 | 40 | 50 | 60

Clamp 2/40
30.00.0029
 Al F28 tumbled,
 Key width 10 mm

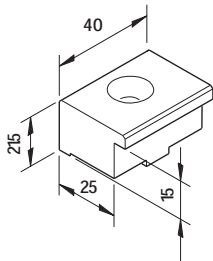

25 | 40 | 50 | 60

Clamp 6/40
30.00.0036
 Al F28 tumbled,
 Key width 10 mm

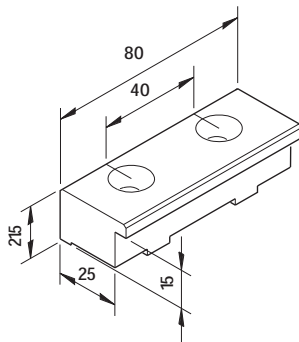

25 | 40 | 50 | 60

Clamp 7/80
30.00.0037
 Al F28 tumbled
 Key width 10 mm

Assembly Components

Nuts

Square nuts are mk's preferred mounting hardware for angles, consoles, plates and accessory components attached to the T-slot. When compared to Slot Nuts and T-Nuts they have a much higher load-bearing capacity due to their larger size and surface area. They should be used wherever the installation situation allows.

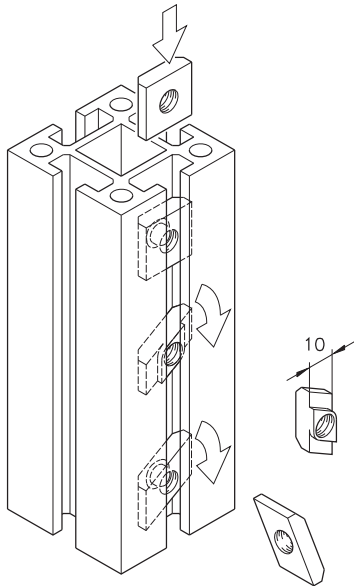

Nuts Series 25

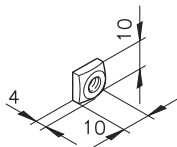
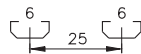

25 40 50 60

Square Nut, Steel Zn
M4 25.50.0540
M5 25.50.0500
M6 25.50.0512

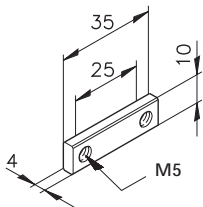

25 40 50 60

Nut 2/25, Steel Zn
M5 25.50.0504
M6 25.50.0513

Nuts Series 40 and 50

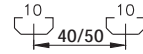

25 40 50 60

Nut 1, Steel Zn
M4 34.08.0001
M5 34.12.0001
M6 34.02.0008
M8 34.01.0001

Nut 1, Stainless Steel
M4 34.08.0004
M5 34.12.0004
M6 34.02.0012
M8 34.01.0024

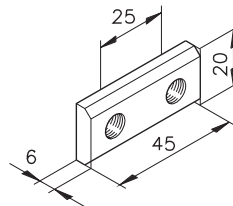
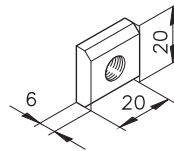

25 40 50 60

Nut 2/25, Steel Zn
M6 34.02.0010
M8 34.01.0002

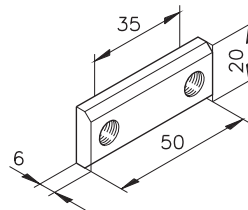

25 40 50 60

Nut 2/35, Steel Zn
M8 34.01.0011

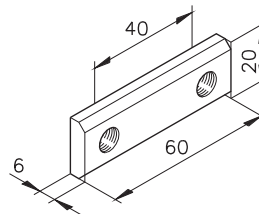

25 40 50 60

Nut 2/40, Steel Zn
M8 34.01.0019

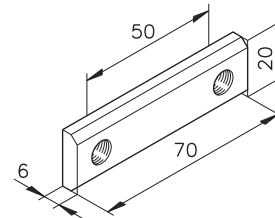

25 40 50 60

Nut 2/50, Steel Zn
M8 34.01.0003

Nuts

Nuts Series 40 and 50

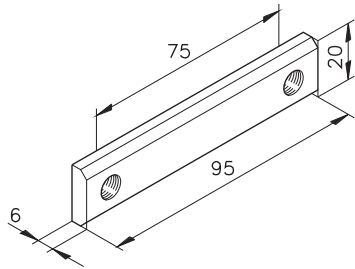
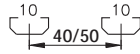

25 40 50 60

Nut 2/75, Steel Zn
M8 34.01.0005

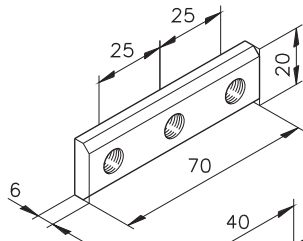

25 40 50 60

Nut 3/25, Steel Zn
M8 34.01.0004

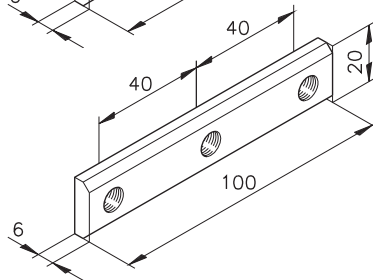

25 40 50 60

Nut 3/40, Steel Zn
M8 34.01.0022

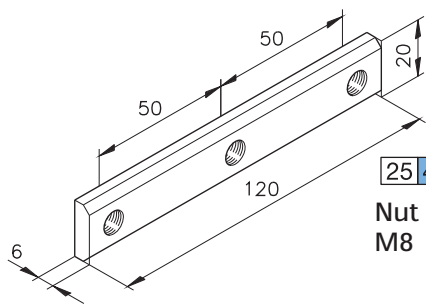

25 40 50 60

Nut 3/50, Steel Zn
M8 34.01.0006

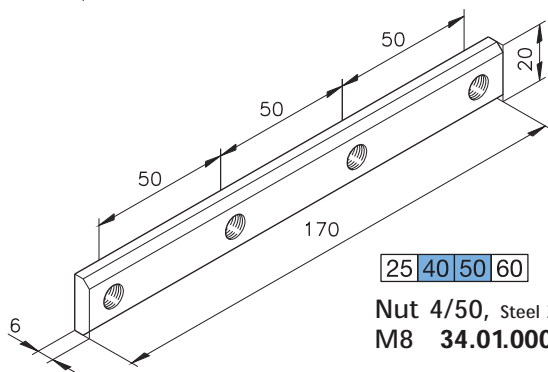

25 40 50 60

Nut 4/50, Steel Zn
M8 34.01.0007

Nuts Series 60

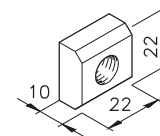

25 40 50 60

Nut 1, Steel Zn
M8 34.60.0101
M10 34.60.0201
M12 34.60.0301

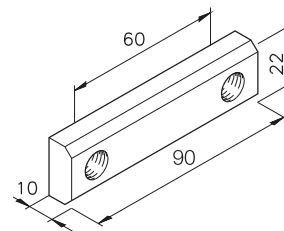

25 40 50 60

Nut 1, Stainless Steel
M12 34.60.0321

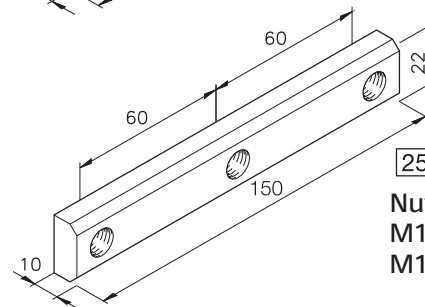

25 40 50 60

Nut 3/60, Steel Zn
M10 34.60.0205
M12 34.60.0305

mk Adapter Nut

By using the adapter nut, keyed angles of series 40 and 50 can be used with series 60 profiles.

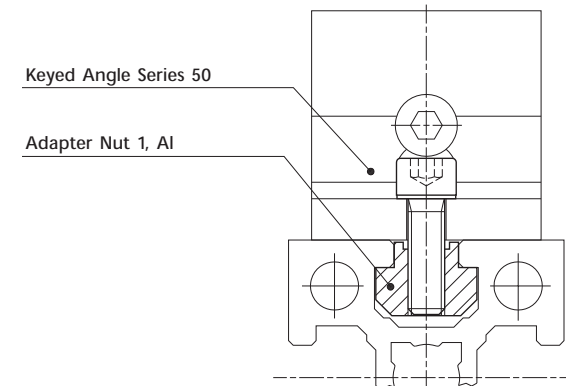

Keyed Angle Series 50

Adapter Nut 1, AI

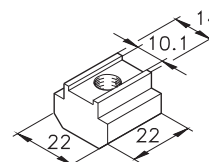

25 40 50 60

Adapter Nut 1, AI
M6 34.60.2001
M8 34.60.2101

Assembly Components

Nuts

Nuts for last-minute assembly

The following components are designed to be inserted into the profiles after an assembly has been finished, or when the profile ends are inaccessible and the standard square nuts can no longer be slid into the T-slots.

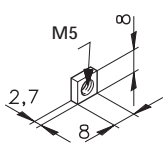

25 40 50 60

Square Nut, Steel Zn
M5 **D05625**

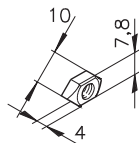

25 40 50 60

Slot Nut, Steel Zn
M4 **25.50.0541**
M5 **25.50.0501**

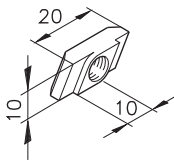

25 40 50 60

T-Nut, Steel Zn
M4 **34.07.0004**
M5 **34.07.0003**
M6 **34.07.0002**
M8 **34.06.0002**

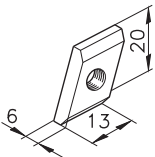

25 40 50 60

Slot Nut, Steel Zn
M5 **34.04.0002**
M6 **34.04.0001**
M8 **34.03.0001**
Slot Nut, Stainless Steel
M6 **34.04.0003**
M8 **34.03.0002**

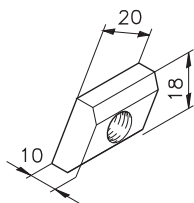

25 40 50 60

Slot Nut, Steel Zn
M8 **34.60.1101**
M10 **34.60.1201**
M12 **34.60.1301**

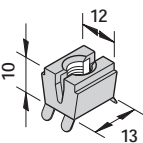

25 40 50 60

Clip, Plastic,
Threaded Insert Steel Zn
M4 **K111020006**
M5 **K111020007**
M6 **K111020008**

25 40 50 60

Clip, Plastic,
Threaded Insert Steel Zn
M4 **34.14.0006**
M5 **34.14.0007**
M6 **34.14.0008**

Flat-Head Inserts

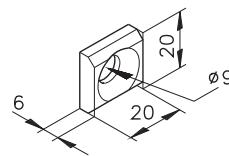

25 40 50 60

Nut S1
Steel Zn
34.09.0001

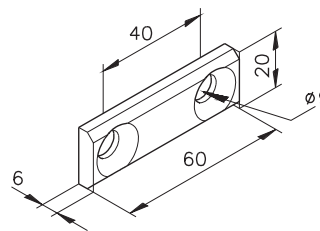

25 40 50 60

Nut S2/40
Steel Zn
34.09.0007

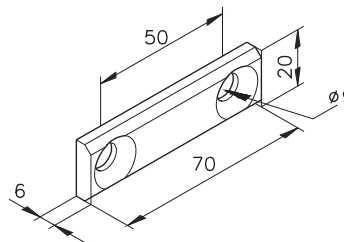

25 40 50 60

Nut S2/50
Steel Zn
34.09.0002

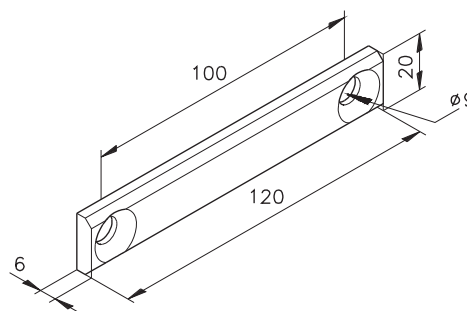

25 40 50 60

Nut S2/100
Steel Zn
34.09.0006

Nuts

Nut Placement and Holding

For the profile series 25, 40 and 50 mk offers components to hold nuts in position when installed into vertical T-slots. This is a significant aid when mounting components at such locations.

Nut Stoppers

For use with our standard square nuts and slot nuts, the nut stoppers offer the ultimate in convenience. They are simply pushed onto the thread of the nut, which is then located where desired in the profile T-slot. When the screw is tightened it displaces the nut stopper. These are single-use components and made of soft PE.

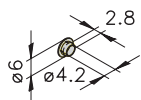
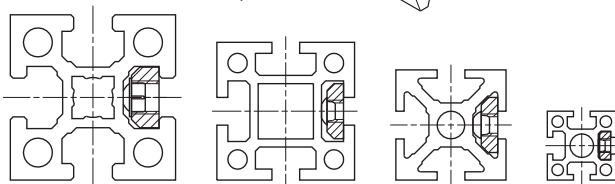
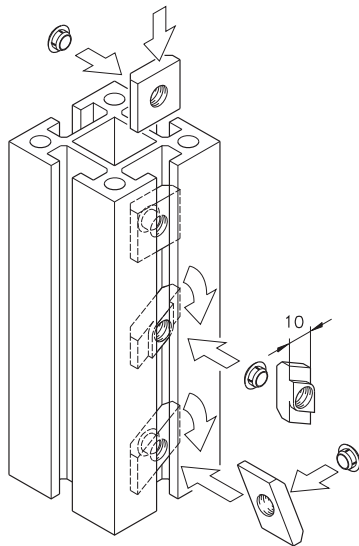

25 40 50 60

Nut Stopper green
M5/Series 25
mk 2553 PE

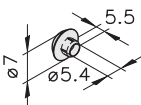

25 40 50 60

Nut Stopper white
M6/Series 40
mk 2554 PE

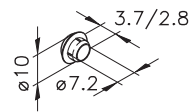

25 40 50 60

Nut Stopper red
M8/Series 40
mk 2555 PE

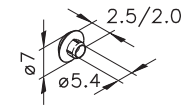

25 40 50 60

Nut Stopper yellow
M6/Series 50
mk 2556 PE

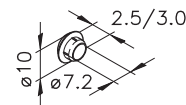

25 40 50 60

Nut Stopper blue
M8/Series 50
mk 2557 PE

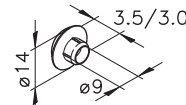

25 40 50 60

Nut Stopper orange
M10/Series 60
mk 2559 PE

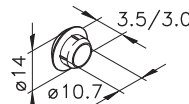

25 40 50 60

Nut Stopper violet
M12/Series 60
mk 2560 PE

Spring Clips

Spring clips hold mk square nuts in vertical T-slots. These clips must be placed prior to beam assembly, and are reusable.

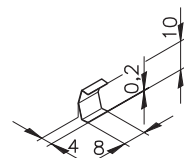

25 40 50 60

Spring Clip for
Nut M5/M6
07.13.0003
Spring Steel

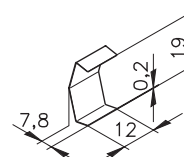

25 40 50 60

Spring Clip for
Nut 1/M8,
M6, M5, M4
07.13.0002
Spring Steel

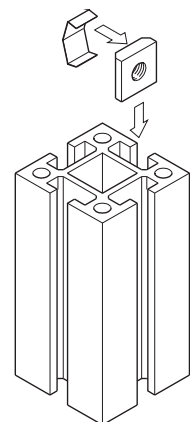

Assembly Components

Grounding

If assemblies are electrified (i.e. lighting, electrical outlets, etc.), VDE 0100-410/413 requires that all conductive elements of the workplace must be connected via a common ground, so that the workplace remain safe in case of an electrical short. As a rule, mk uses a grounding method in all its standard workstation systems which is applied whether the workstation has electrical components or not. Using our PE-Nuts, this grounding is accomplished without the use of additional wires. This means that in the case of later electric additions, only the electric element itself must be connected with the workplace.

Angle connection with PE-Nuts

The nut is stamped to include protrusions which break through the anodized surface of the profile. This provides conductivity through the screw and thus ensures electrical conductivity of the connection.

Nut 1 M8 PE 34.01.0018

SHCS M8 x 16 DIN 912
D0912816

Angle Al

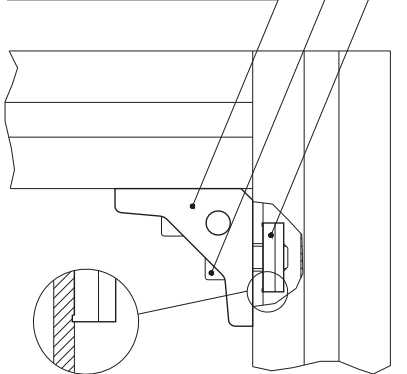

Grounding Nuts

A defined grounding location of an mk workplace for attachment to a common ground.

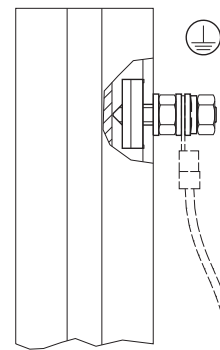

Ground-connection
B02.99.151

Grounding Nuts

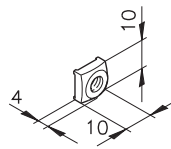

25 40 50 60

Square Nut PE
M5 25.50.0508
M6 25.50.0518

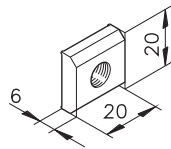

25 40 50 60

Nut 1 PE
M8 34.01.0018
M6 34.02.0018

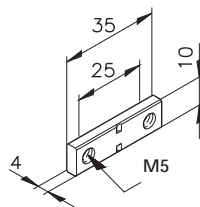

25 40 50 60

Nut 2/25 PE
M5 25.50.0505

Screws

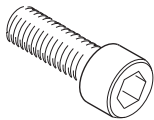

SHCS

DIN EN ISO 4762, 8.8 Zn

| | |
|----------|------------------|
| M4 x 10 | D0912410 |
| M5 x 8 | D091258 |
| M5 x 10 | D0912510 |
| M5 x 12 | D0912512 |
| M5 x 16 | D0912516 |
| M6 x 10 | D0912610 |
| M6 x 12 | D0912612 |
| M6 x 16 | D0912616 |
| M6 x 20 | D0912620 |
| M8 x 12 | D0912812 |
| M8 x 16 | D0912816 |
| M8 x 20 | D0912820 |
| M8 x 25 | D0912825 |
| M8 x 30 | D0912830 |
| M8 x 35 | D0912835 |
| M8 x 40 | D0912840 |
| M12 x 20 | D09121220 |
| M12 x 25 | D09121225 |

SHCS

DIN EN ISO 4762, Stainless Steel

| | |
|---------|-------------------|
| M8 x 16 | D0912816A2 |
| M8 x 20 | D0912820A2 |

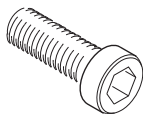

SHCS DIN 6912, 8.8 Zn

| | |
|----------|------------------|
| M5 x 8 | D691258 |
| M5 x 10 | D6912510 |
| M5 x 12 | D6912512 |
| M5 x 20 | D6912520 |
| M6 x 16 | D6912616 |
| M6 x 20 | D6912620 |
| M8 x 16 | D6912816 |
| M8 x 20 | D6912820 |
| M8 x 25 | D6912825 |
| M8 x 30 | D6912830 |
| M10 x 25 | D69121025 |
| M12 x 30 | D69121230 |

SHCS DIN 6912, Stainless Steel

| | |
|---------|-------------------|
| M8 x 16 | D6912816A2 |
| M8 x 20 | D6912820A2 |

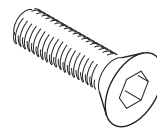

FH-SHCS

DIN EN ISO 10642, 8.8 Zn

| | |
|---------|-----------------|
| M4 x 6 | D799146 |
| M4 x 10 | D7991410 |
| M4 x 12 | D7991412 |
| M4 x 16 | D7991416 |
| M5 x 8 | D799158 |
| M5 x 10 | D7991510 |
| M5 x 12 | D7991512 |
| M5 x 16 | D7991516 |
| M5 x 25 | D7991525 |
| M6 x 10 | D7991610 |
| M6 x 12 | D7991612 |
| M6 x 16 | D7991616 |
| M6 x 20 | D7991620 |
| M8 x 12 | D7991812 |
| M8 x 16 | D7991816 |
| M8 x 20 | D7991820 |
| M8 x 25 | D7991825 |
| M8 x 30 | D7991830 |

FH-SHCS

DIN EN ISO 10642, Stainless Steel

| | |
|---------|-------------------|
| M4 x 10 | D7991410A2 |
| M4 x 16 | D7991416A2 |
| M4 x 35 | D7991435A2 |
| M5 x 8 | D799158A2 |
| M5 x 10 | D7991510A2 |
| M6 x 12 | D7991612A2 |
| M6 x 16 | D7991616A2 |
| M8 x 16 | D7991816A2 |
| M8 x 20 | D7991820A2 |
| M8 x 35 | D7991835A2 |

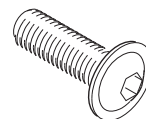

FBH-Screw, 10.9 black Zn

| | |
|---------|-------------------|
| M5 x 10 | K112010021 |
| M6 x 8 | K112010010 |
| M6 x 10 | K112010011 |
| M6 x 12 | K112010012 |
| M6 x 16 | K112010013 |
| M8 x 12 | K112010002 |
| M8 x 16 | K112010003 |
| M8 x 20 | K112010004 |

Assembly Components

Screws, Nuts and Spring Washers

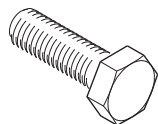

Hex Head Screws

DIN EN ISO 4017, 8.8 Zn

| | |
|----------|------------------|
| M6 x 8 | D093368 |
| M6 x 16 | D0933616 |
| M6 x 20 | D0933620 |
| M6 x 25 | D0933625 |
| M6 x 30 | D0933630 |
| M6 x 35 | D0933635 |
| M8 x 12 | D0933812 |
| M8 x 16 | D0933816 |
| M8 x 20 | D0933820 |
| M8 x 25 | D0933825 |
| M8 x 30 | D0933830 |
| M8 x 35 | D0933835 |
| M8 x 40 | D0933840 |
| M10 x 20 | D09331020 |
| M10 x 25 | D09331025 |
| M10 x 30 | D09331030 |
| M12 x 30 | D09331230 |

Hex Head Screws

DIN EN ISO 4017, Stainless Steel

| | |
|---------|-------------------|
| M8 x 16 | D0933816A2 |
| M8 x 20 | D0933820A2 |
| M8 x 25 | D0933825A2 |

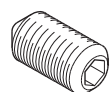

Set Screw

DIN EN ISO 4027, 8.8 Zn

| | |
|---------|-----------------|
| M4 x 6 | D091446 |
| M4 x 8 | D091448 |
| M4 x 10 | D0914410 |
| M5 x 6 | D091456 |
| M5 x 8 | D091458 |
| M5 x 10 | D0914510 |
| M6 x 6 | D091466 |
| M6 x 8 | D091468 |
| M6 x 10 | D0914610 |
| M8 x 10 | D0914810 |
| M8 x 12 | D0914812 |
| M8 x 16 | D0914816 |
| M8 x 20 | D0914820 |

Set Screw

DIN EN ISO 4027, Stainless Steel

| | |
|---------|-------------------|
| M6 x 6 | D091466A2 |
| M6 x 8 | D091468A2 |
| M6 x 10 | D0914610A2 |
| M8 x 10 | D0914810A2 |
| M8 x 16 | D0914816A2 |

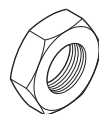

Hex Nut

DIN EN ISO 4032, 8 Zn

| | |
|-----|----------------|
| M5 | D09345 |
| M6 | D09346 |
| M8 | D09348 |
| M10 | D093410 |
| M12 | D093412 |

Hex Nut

DIN EN ISO 4032, Stainless Steel

| | |
|----|-----------------|
| M5 | D09345A2 |
| M6 | D09346A2 |
| M8 | D09348A2 |



Rib Washer,

Steel Zn

| | |
|--------|-------------------|
| ø 4,3 | K111010014 |
| ø 5,3 | K111010015 |
| ø 6,4 | K111010016 |
| ø 8,4 | K111010017 |
| ø 10,5 | K111010018 |
| ø 12 | K111010019 |

Rib Washer,

Stainless Steel 1.4301

| | |
|--------|-------------------|
| ø 4,3 | K111010020 |
| ø 5,3 | K111010021 |
| ø 6,4 | K111010022 |
| ø 8,4 | K111010023 |
| ø 10,5 | K111010024 |
| ø 12 | K111010025 |

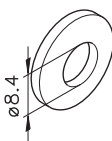

Spring Washer,

Steel Zn

| | |
|-------|---------------|
| ø 8,4 | D67968 |
|-------|---------------|

Stainless Steel



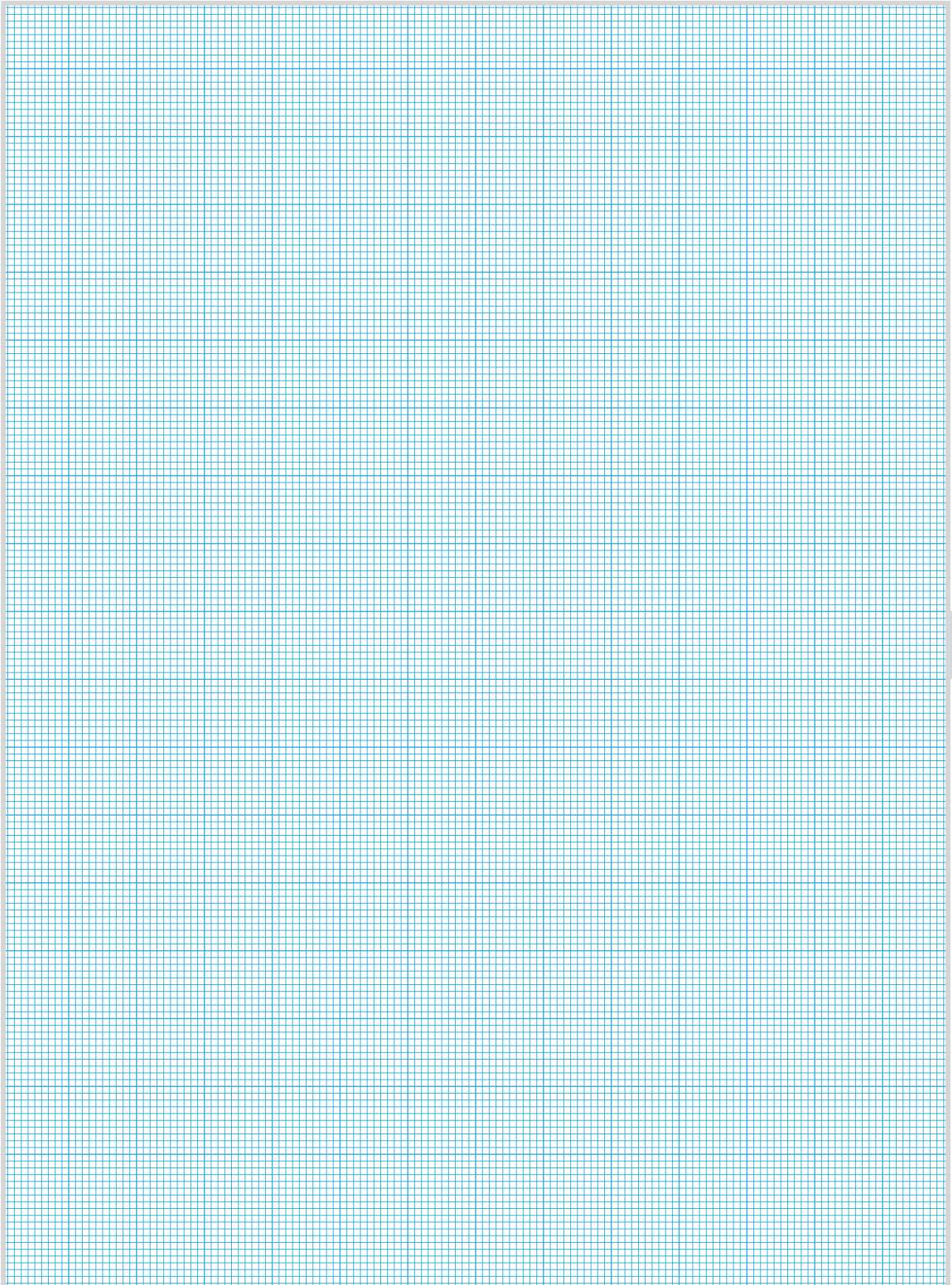









| | |
|-------|-----------------|
| ø 8,4 | D67968A2 |
|-------|-----------------|



mk Accessory Components













Contents mk Accessory Components



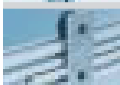

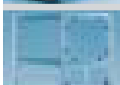

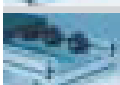

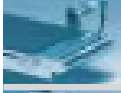

| | | |
|---|---------------------------|-----|
|  | Floor Mounting | |
|  | Floor Mounting Brackets | 148 |
|  | Floor Mounting Plates | 149 |
|  | Base Plates | 150 |
|  | Cast Bases | 153 |
|  | Pedestal Bases | 154 |
|  | Pad Blocks and Plates | 158 |
|  | Leveling Pads | 163 |
|  | Support Brackets | 165 |
|  | Fixed and Swivel Casters | 166 |
|  | Hoists | 168 |
|  | Operating elements | |
|  | Handwheels | 169 |
|  | Handles | 170 |
|  | Adjustable Handle | 171 |

mk Accessory Components

Contents mk Accessory Components

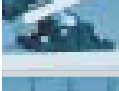
| | | |
|---|------------------------------|-----|
|  | Door Components | |
|  | Hinges | 172 |
|  | Hinges for Panels | 176 |
|  | Ball latches | 177 |
|  | External locks | 178 |
|  | Internal locks | 179 |
|  | Slide Bolt | 180 |
|  | Components for Sliding Doors | 181 |
|  | Closure and Seal Strips | 182 |
|  | Paneling and Accessories | 184 |
|  | Rollers | |
|  | Mini-Rollers | 192 |
|  | Carriage Rollers | 193 |

Contents mk Accessory Components

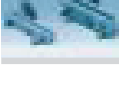
| | | |
|---|-------------------------------------|-----|
|  | Pneumatic Components | 195 |
|  | Electric Components | |
|  | Sensor Brackets | 198 |
|  | Wireways | 199 |
|  | End Caps | 200 |
|  | Wear Strips | 204 |
|  | Swivel Joints | 208 |
|  | Ball Bases, Clamps and Rods | 212 |
|  | Accessory Components for Guardrails | 218 |
|  | Glides and Bushings | 220 |
|  | Bumpers | 222 |
|  | Tools | 224 |

Accessory Components

Floor Mounting

Floor Mounting Brackets

Series 40

Using the floor mounting brackets, floor height variations of up to 10 mm may be compensated. The brackets may be fastened to the floor with anchors and are tightened with the included M8 hex nut.

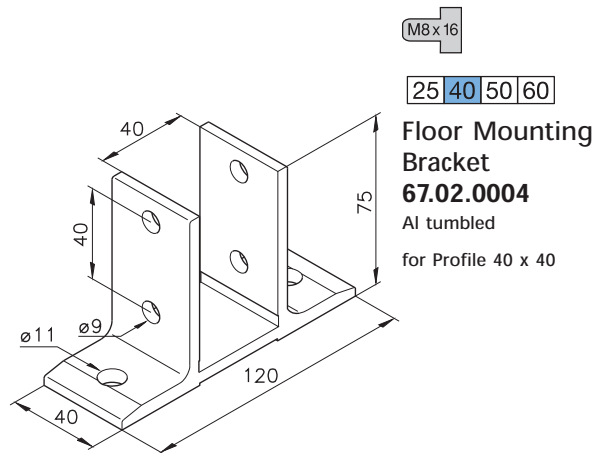
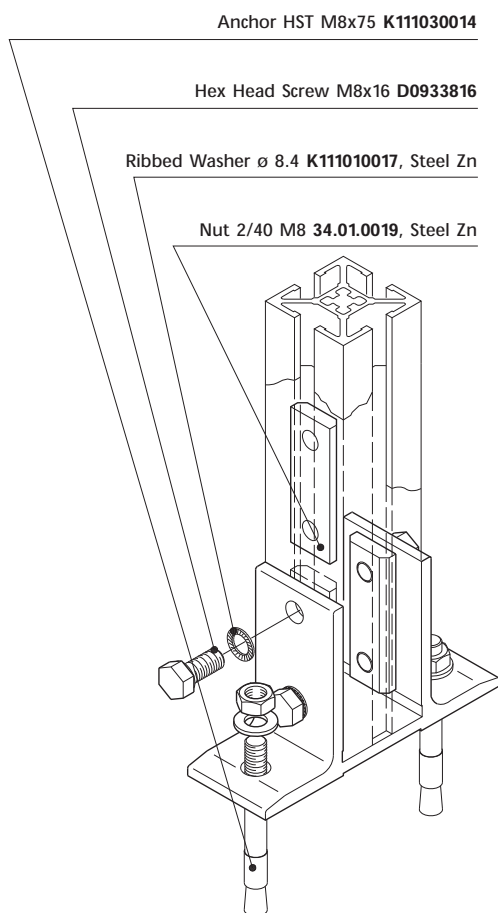

Floor Mounting

Floor Mounting Plates

Series 40

Floor mounting plates can be used to anchor equipment such as stands, guards, workbenches, frames, etc. firmly to the floor.

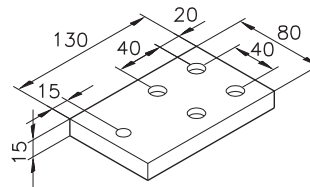

25 | 40 | 50 | 60

Plate 40/17

50.03.0025

Al tumbled

for Profile 80 x 80

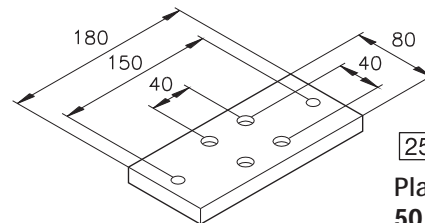

25 | 40 | 50 | 60

Plate 40/18

50.03.0026

Al tumbled

for Profile 80 x 80

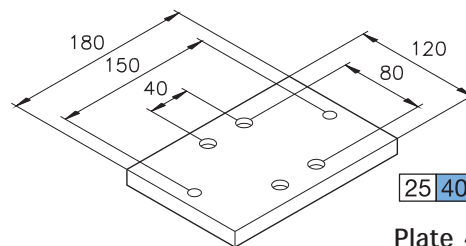

25 | 40 | 50 | 60

Plate 40/20

50.03.0028

Al tumbled

for Profile 80 x 120

optional Anchor HST
M8x75, K111030014

SHCS M8 x 20,
D0912820

Ribbed Washer \varnothing 8.4,
Spring Steel Zn, K111010017

Threaded Insert M8,
9S20K, K112030008

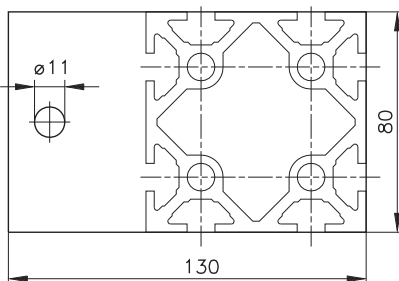
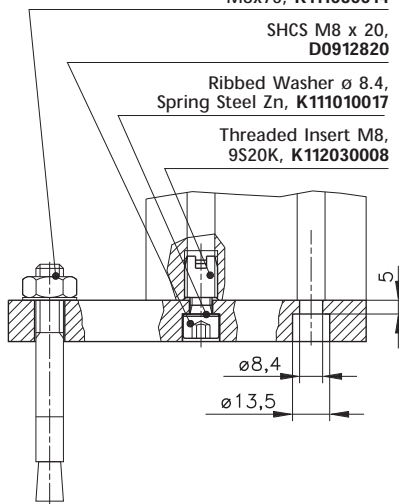

Accessory Components

Floor Mounting

Base Plates

Series 40

Base Plates are used for robust floor mounting. They can also be used as flange-mounting for other profiles.

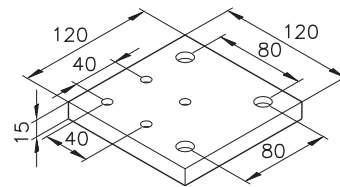
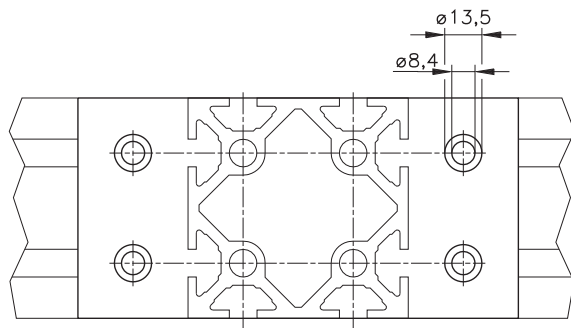
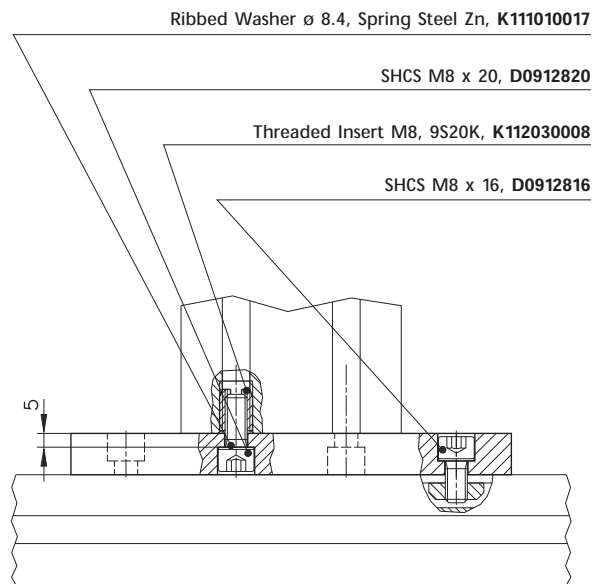

25 40 50 60

Base Plate 40/1
50.03.0009

Al tumbled
for Profile 80 x 80

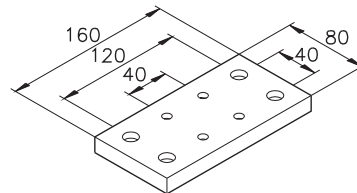

25 40 50 60

Base Plate 40/2
50.03.0010

Al tumbled
for Profile 80 x 80

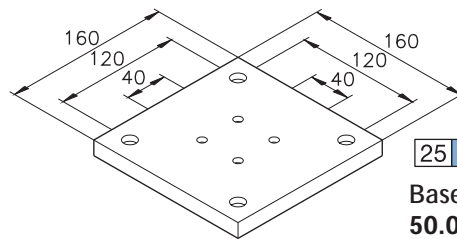

25 40 50 60

Base Plate 40/3
50.03.0011

Al tumbled
for Profile 80 x 80

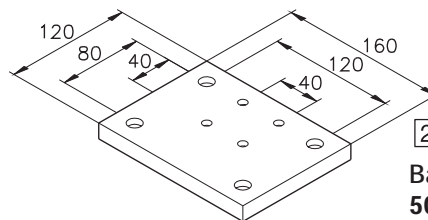

25 40 50 60

Base Plate 40/4
50.03.0012

Al tumbled
for Profile 80 x 80



Floor Mounting

Base Plates

Series 50

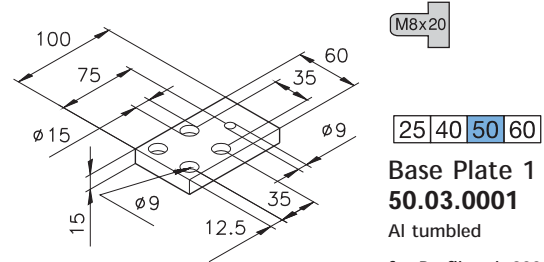

for Profile mk 2000
and mk 2017

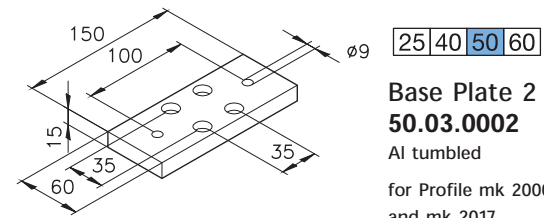

for Profile mk 2000
and mk 2017

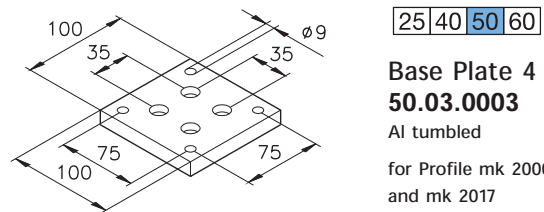

for Profile mk 2000
and mk 2017

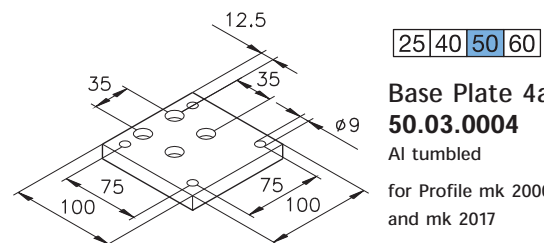

for Profile mk 2000
and mk 2017

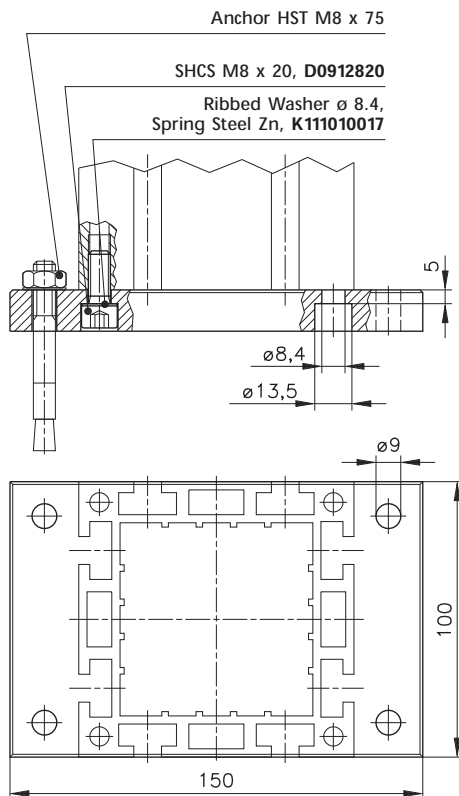

Accessory Components

Floor Mounting

Base Plates

Series 50

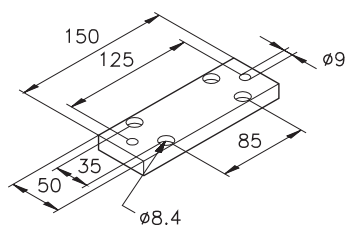

25 40 50 60

Base Plate 5
50.03.0005
 Al tumbled
 for Profile mk 2004

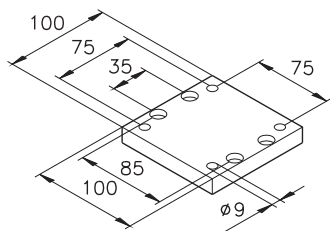

25 40 50 60

Base Plate 6
50.03.0006
 Al tumbled
 for Profile mk 2004

25 40 50 60

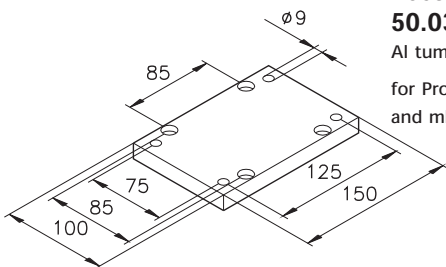

Base Plate 7
50.03.0007
 Al tumbled
 for Profile mk 2005
 and mk 2011

25 40 50 60

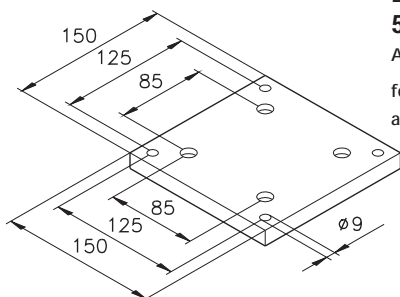

Base Plate 8
50.03.0008
 Al tumbled
 for Profile mk 2005
 and mk 2011

Series 60

Ribbed Washer ϕ 8.4
 Spring Steel Zn, K111010017

Threaded Insert M8
 9S20K, K112030008

SHCS M8 x 20
 D0912820

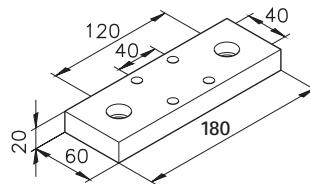
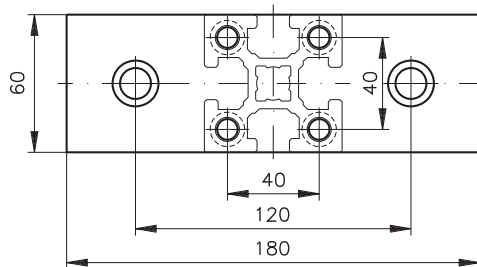
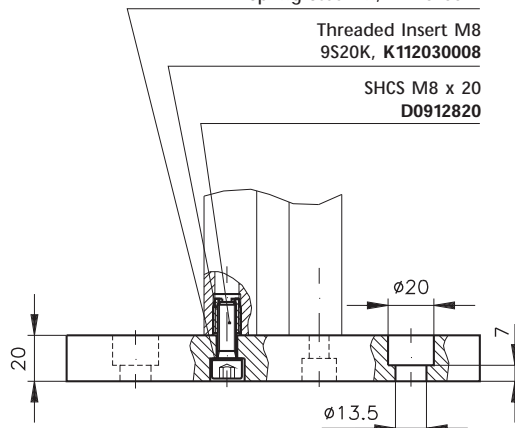

25 40 50 60

Base Plate 60/2
50.03.6002
 Al tumbled
 for Profile mk 2060.01

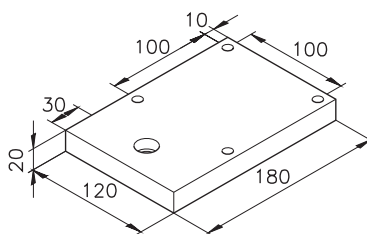

25 40 50 60

Base Plate 60/8
50.03.6008
 Al tumbled
 for Profile mk 2060.05

Floor Mounting

Cast Bases

Applications for Cast Bases include, securing stands or pillars to the floor, or to other profiles.

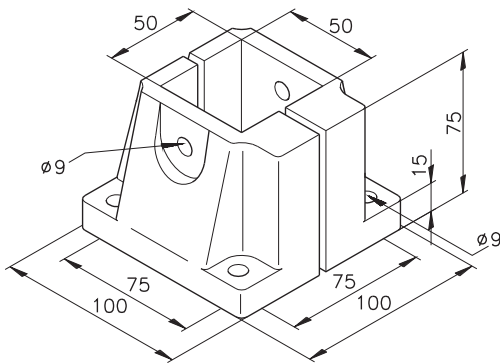

25 40 **50** 60

Cast Base 1
65.00.0001
 Cast Aluminum,
 0.8 kg

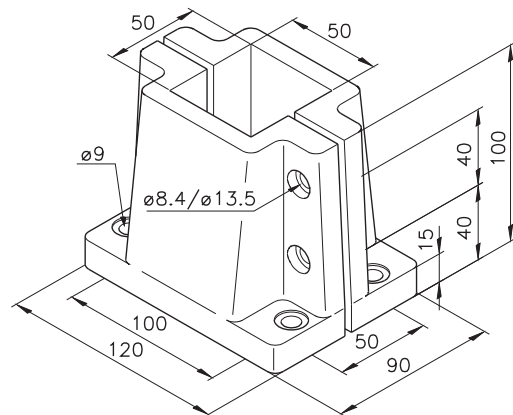

25 40 **50** 60

Cast Base 5
65.00.0005
 Cast Aluminum,
 1.35 kg

Accessory Components

Floor Mounting

Pedestal Bases

Pedestal Bases ensure a stable platform for such things as frames, stands or guards. They can be used with all our profile series and have a clean design.

The bases are reinforced with more material at the corners, and it is possible to add additional holes at these locations. The bases are stocked in black (similar to RAL 9005), although other colors are available on request. Order either the individual plate or a complete assembly with included hardware (Anchor HST and Leveling Screws).

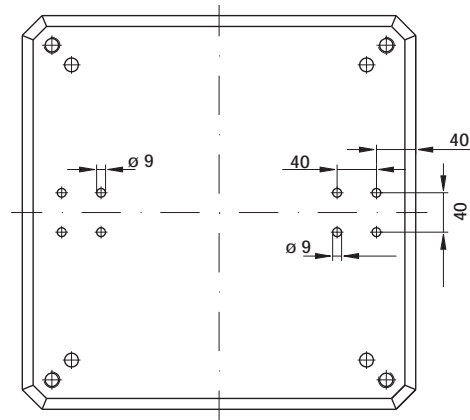
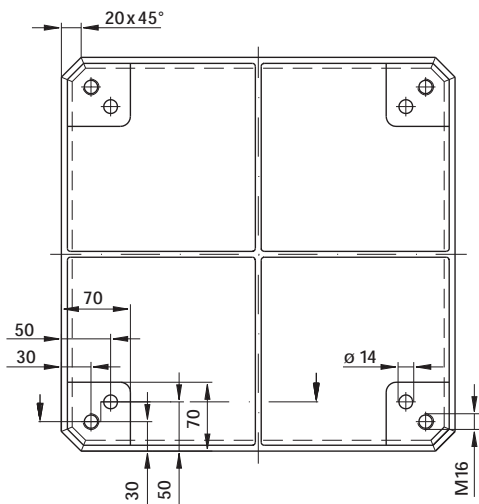

Drill pattern example

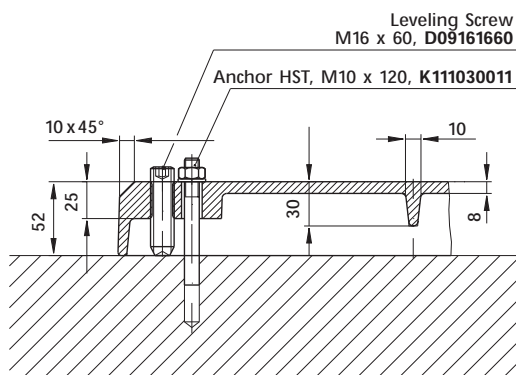

On request we will rework the bases to your specifications (see drill pattern example). Please notice the location of the reinforcements (shown using centerlines) when specifying rework, as drilling through these reinforcements will adversely affect load capacity.

Floor Mounting

Pedestal Bases

The centerlines denote the location of a reinforcement which runs on the underside of the plate.

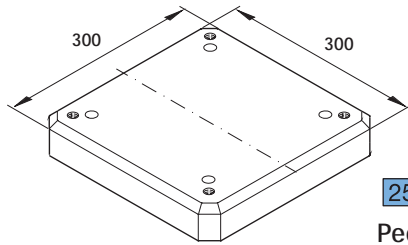

25 | 40 | 50 | 60

Pedestal Base 6
50.02.0088

H=52 mm
 GG-26, painted black
 Weight 10.5 kg

B46.07.274
 with anchors and
 leveling screws

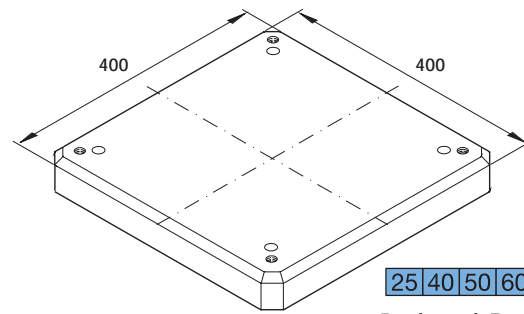

25 | 40 | 50 | 60

Pedestal Base 8
50.02.0076

H=52 mm
 GG-26, painted black
 Weight 13.7 kg

B46.07.276
 with anchors and
 leveling screws

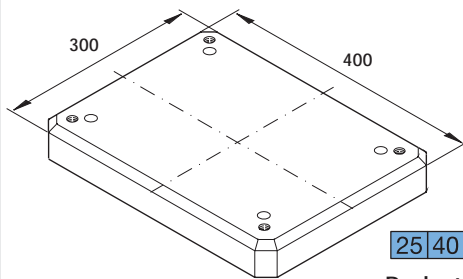

25 | 40 | 50 | 60

Pedestal Base 7
50.02.0089

H=52 mm
 GG-26, painted black
 Weight 12.1 kg

B46.07.275
 with anchors and
 leveling screws

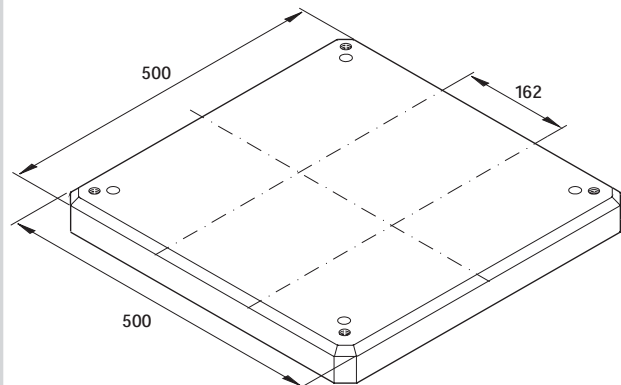

25 | 40 | 50 | 60

Pedestal Base 9
50.02.0077

H=52 mm
 GG-26, painted black
 Weight 28.6 kg

B46.07.277
 with anchors and
 leveling screws

Accessory Components

Floor Mounting

Pedestal Bases



Pedestal Bases ensure a stable platform for heavy machine frames, gantries and stands. The bases are pre-drilled for attaching some of the basic system profiles and painted black (similar to RAL 9005). The undrilled bases only include the corner holes for leveling and floor mounting. Reworking and painting bases to customer specifications is possible on request.

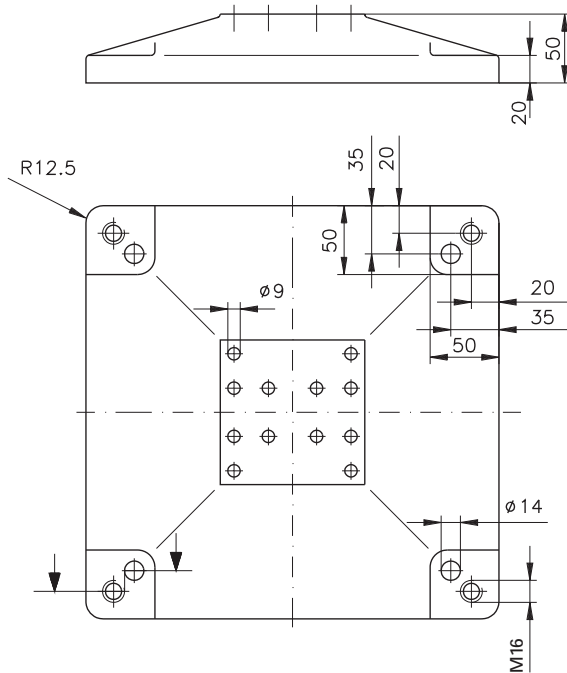

Floor attachment:

Anchor HST, M10 x 120, K111030011

Leveling Screw M16 x 40, D09161640

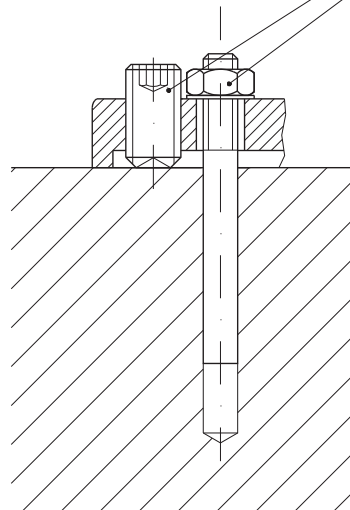

Floor Mounting

Pedestal Bases

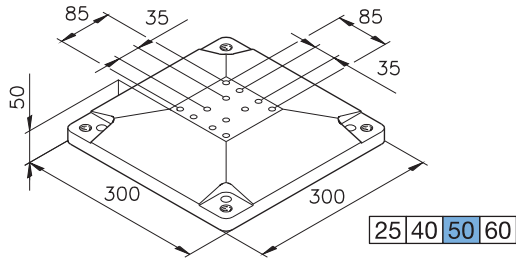

Pedestal Base 4
50.02.0028

Pre-drilled for
 mk 2000, mk 2004,
 mk 2005, mk 2011

Cast Iron,
 painted matte black,
 6.8 kg

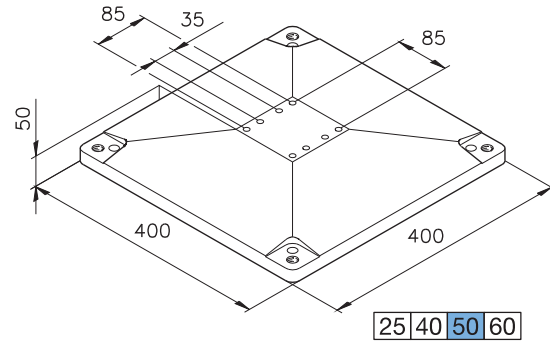

Pedestal Base 2
50.02.0026

Pre-drilled for
 mk 2004, mk 2005,
 mk 2011

Cast Iron,
 painted matte black,
 11.5 kg

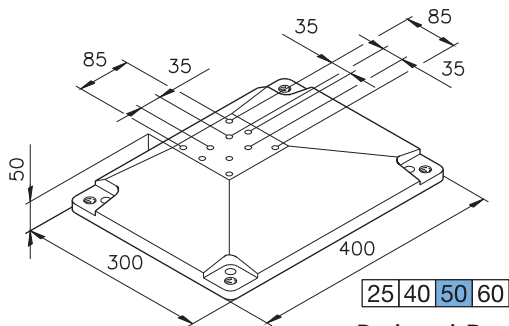

Pedestal Base 1
50.02.0023

Pre-drilled for
 mk 2000, mk 2004, mk 2005

Cast Iron,
 painted matte black,
 8 kg

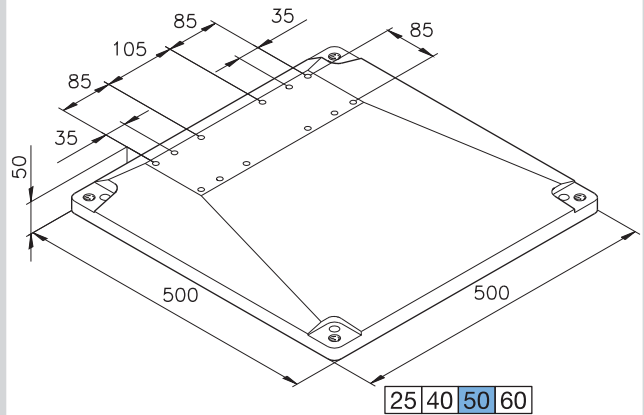

Pedestal Base 5
50.02.0029

Pre-drilled for
 2 x mk 2004, mk 2005,
 mk 2011

Cast Iron,
 painted matte black,
 16.6 kg

Accessory Components

Floor Mounting

Pad Blocks and Plates

for horizontal profiles

Pad blocks accept leveling pads, swivel and fixed casters, and hoists. Suitable pad blocks and plates are available for all common profiles and leveling pads.

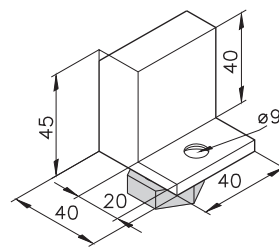
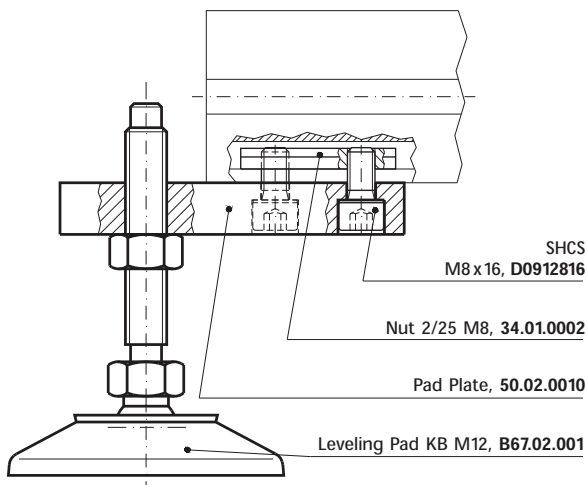
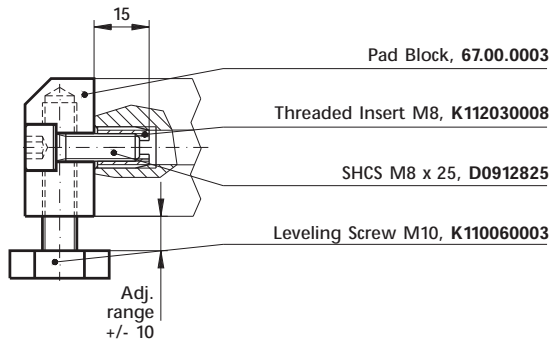

DIN 7991

25 | 40 | 50 | 60

Pad Block M10
67.00.0010

Al tumbled,
without Leveling Screw
for Profile 40 x 40
Load Capacity 1,000 N

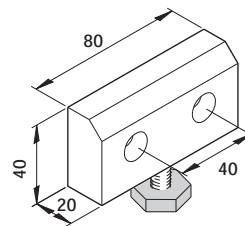

25 | 40 | 50 | 60

Pad Block M10
67.00.0003

Al tumbled,
without Leveling Screw
for Profile 40 x 80
Load Capacity 1,000 N

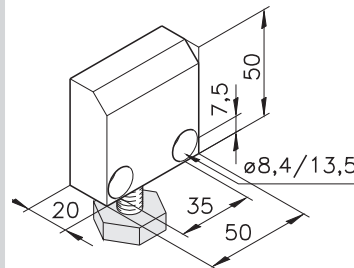

25 | 40 | 50 | 60

Pad Block M10
67.00.0002

Al tumbled,
without Leveling Screw
for Profile mk 2000
Load Capacity 1,000 N

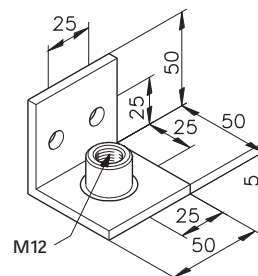

25 | 40 | 50 | 60

Pad Angle M12
B67.02.009

Pad Angle M16
B67.02.010

Steel Zn

Load Capacity 1,500 N

Floor Mounting

Pad Blocks and Plates

for horizontal profiles



25 40 50 60

Pad Plate D M12

50.02.0010

Pad Plate D M16

50.02.0011

Al tumbled

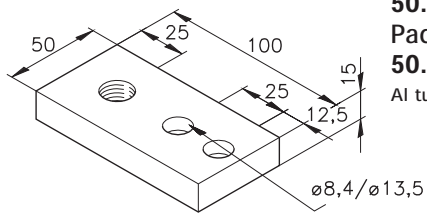

25 40 50 60

Pad Plate F M16

50.02.0018

Al tumbled

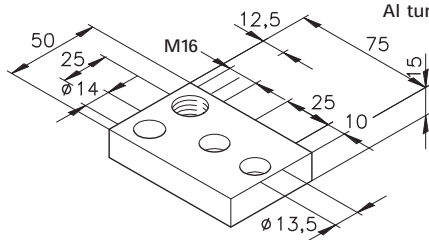

25 40 50 60

Pad Plate G M16

50.02.0007

Pad Plate G M20

50.02.0008

Al tumbled

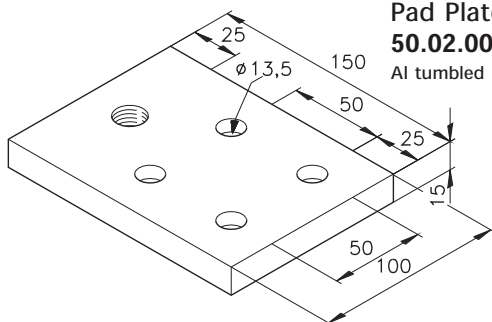

Accessory Components

Floor Mounting

Pad Blocks and Plates

for vertical profiles



M8x20

25 40 50 60

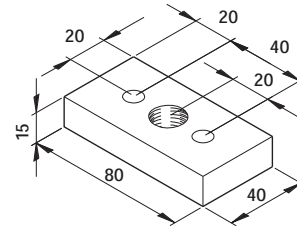

Pad Plate I M10

50.02.0041

Pad Plate I M12

50.02.0035

Pad Plate I M16

50.02.0030

Al tumbled

for Profile mk 2040.02,
mk 2040.41, mk 2040.52

Load Capacity 6,000 N

25 40 50 60

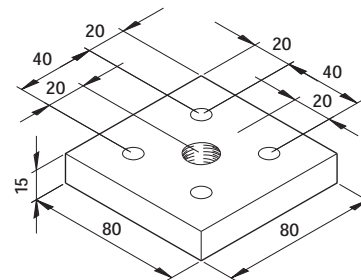

Pad Plate J M10

50.02.0042

Pad Plate J M12

50.02.0067

Pad Plate J M16

50.02.0032

Pad Plate J M20

50.02.0050

Al tumbled

for Profile mk 2040.03,
mk 2040.45

Load Capacity 6,000 N

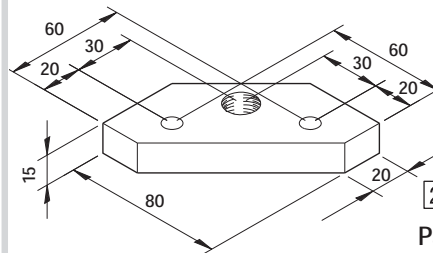

25 40 50 60

Pad Plate K M10

50.02.0043

Pad Plate K M16

50.02.0040

Al tumbled

for Profile mk 2040.04

Load Capacity 4,150 N

M8x16

25 40 50 60

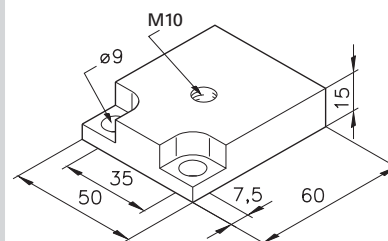

Pad Plate M10

50.02.0068

Al tumbled

for Profile mk 2040.38

Threaded Insert Helicoil M10,
K112030110
Leveling Screw M10,
K110060003

Leveling Screw M10,
K110060003

Plug 7, 79.00.0004

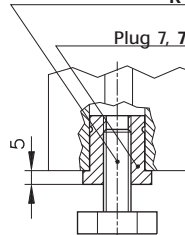
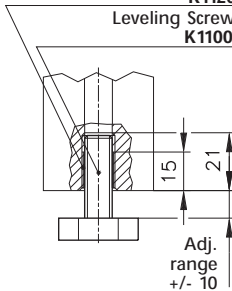

Adj.
range
+/- 10

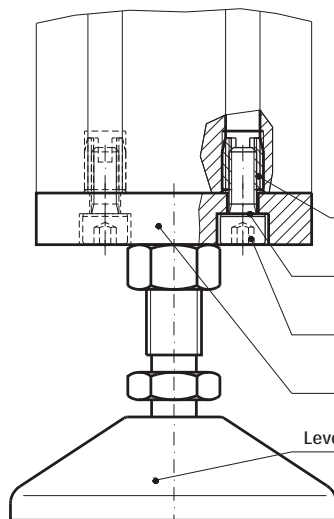

Threaded Insert M8,
9S20K, K112030008

Ribbed Washer \varnothing 8.4,
Spring Steel Zn, K111010017

SHCS M8 x 20,
D0912820

Pad Plate, 50.02.0032

Leveling Pad KB M16, B67.02.002

Floor Mounting

Pad Blocks and Plates

for vertical profiles

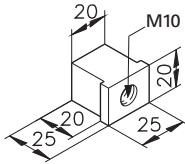

25 | 40 | 50 | 60

Plug 7 79.00.0004

Al tumbled
 for Profile mk 2000
 Load Capacity 1,000 N



25 | 40 | 50 | 60

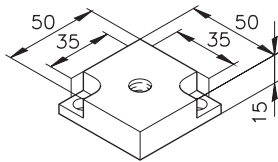

Pad Plate A M10 50.09.0013

Pad Plate A M12 50.09.0044

Pad Plate A M16 50.09.0045

Al tumbled
 for Profile mk 2000
 Load Capacity 6,000 N

25 | 40 | 50 | 60

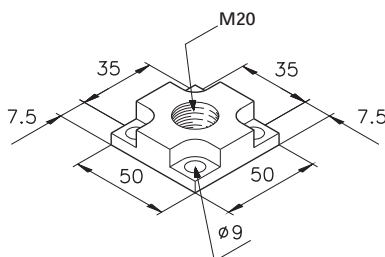

Pad Plate 1 M20 50.09.0037

Steel Zn
 for Profile mk 2000
 Load Capacity 12,000 N



25 | 40 | 50 | 60

Pad Plate B M16 50.02.0003

Pad Plate B M20
50.02.0004
 Al tumbled
 Load Capacity 6,000 N

Pad Plate 3 M20 50.09.0038

Steel Zn
 for Profile mk 2004
 Load Capacity 12,000 N

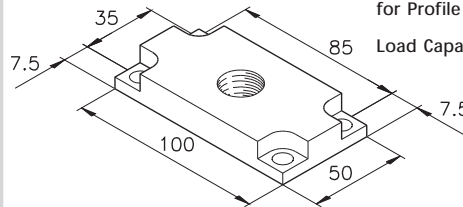

25 | 40 | 50 | 60

Pad Plate C M16 50.02.0001

Pad Plate C M20 50.02.0002

Al tumbled
 Load Capacity 6,000 N

Pad Plate I M20 50.09.0039

Steel Zn
 for Profile mk 2005, mk 2011
 Load Capacity 12,000 N

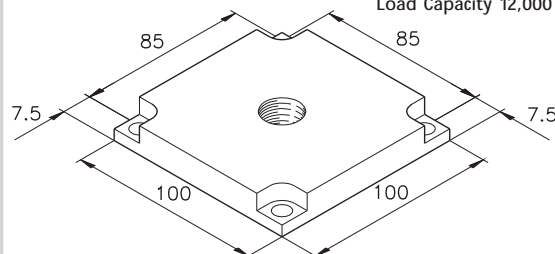

Accessory Components

Floor Mounting

Pad Blocks and Plates

for vertical profiles



25 | 40 | 50 | 60

Pad Plate 60/4 M16

50.02.6004

Pad Plate 60/5 M20

50.02.6005

Al tumbled

for Profile mk 2060.02

Load Capacity 10,000 N

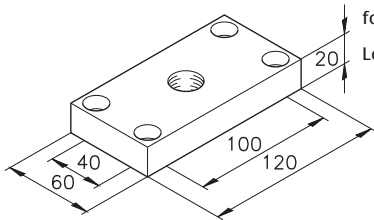

25 | 40 | 50 | 60

Pad Plate 60/8 M16

50.02.6008

Pad Plate 60/9 M20

50.02.6009

Al tumbled

for Profile mk 2060.05

Load Capacity 10,000 N

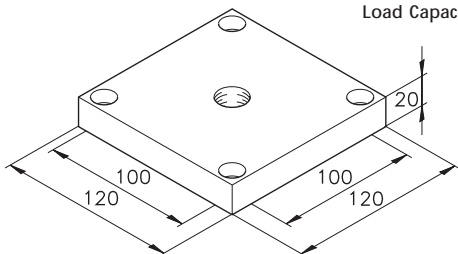

Floor Mounting

Leveling Pads

The leveling pads are used in conjunction with the corresponding pad blocks or plates. All leveling pads have an adjustment range for compensating differences in floor elevation. Leveling pads with ball and socket joints have a swivel range of approximately $\pm 20^\circ$ and also compensate for unevenness in the floor.

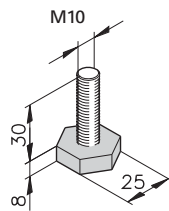

25 40 50 60

Leveling Screw M8 K110060004

Adj. range 10 mm

Leveling Screw M10 K110060003

Adj. range 10 mm

Plastic/Steel

Load Capacity 1,000 N

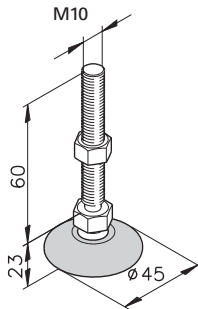

25 40 50 60

Leveling Pad KA M10 B67.02.057

Adj. range 25 mm

Spindle Steel Zn,
Plastic Pad,
with Ball Base

Load Capacity 750 N

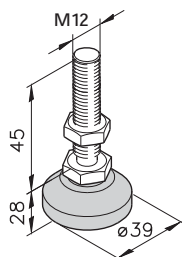

25 40 50 60

Leveling Pad M12 B67.02.076

Adj. range 22 mm

Spindle Steel Zn,
Plastic Pad

Load Capacity 1,000 N

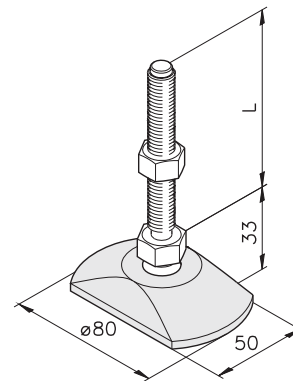

25 40 50 60

Leveling Pad KC M12 B67.02.077

Spindle length 50 mm,
Adj. range 15 mm

Leveling Pad KC M12 B67.02.027

Spindle length 75 mm,
Adj. range 45 mm

Leveling Pad KC M16 B67.02.028

Spindle length 85 mm,
Adj. range 50 mm

Spindle Steel Zn,
Plastic Pad,
with Ball Base

Load Capacity 1,000 N

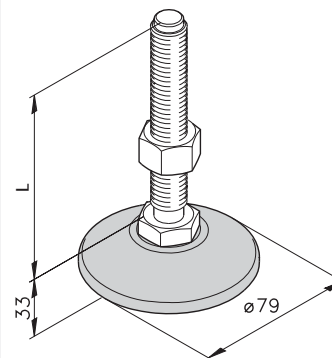

25 40 50 60

Leveling Pad KB M12 B67.02.075

Spindle length 50 mm,
Adj. range 15 mm

Leveling Pad KB M12 B67.02.001

Spindle length 75 mm,
Adj. range 45 mm

Leveling Pad KB M16 B67.02.002

Spindle length 85 mm,
Adj. range 50 mm

Spindle Steel Zn,
Plastic Pad,
glass-fiber reinforced,
with Ball Base

Load Capacity 1,500 N

Accessory Components

Floor Mounting

Leveling Pads

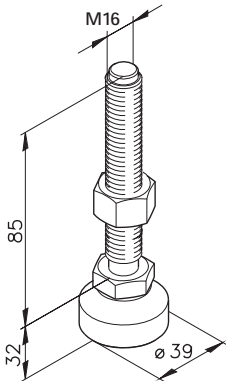

25 40 50 60

Leveling Pad EB M16 B67.02.040

Adj. range 50 mm

Stainless Steel Pad 1.4305,
Spindle Steel Zn,
with Ball Base

Load Capacity 25,000 N

25 40 50 60

Leveling Pad GD M16 B67.02.005

Spindle length 85 mm,
Adj. range 50 mm

Leveling Pad GD M20 B67.02.006

Spindle length 120 mm,
Adj. range 80 mm

Cast Iron Pad
with Rubber Damping Pad,
Spindle Steel Zn,
with Ball Base

Load Capacity 25,000 N

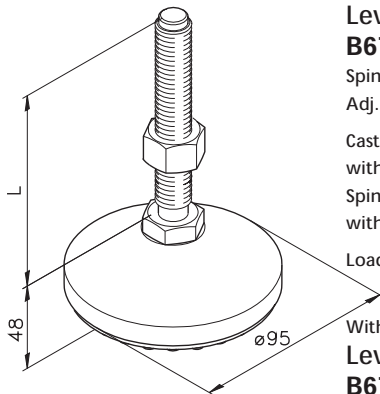

Without Damping

Leveling Pad GA M16 B67.02.003

Leveling Pad GA M20 B67.02.004

25 40 50 60

Leveling Pad GB M16 B67.02.032

Spindle length 85 mm,
Adj. range 50 mm

Leveling Pad GB M20 B67.02.031

Spindle length 120 mm,
Adj. range 80 mm

Cast Iron Pad,
Spindle Steel Zn,
with Ball Base

Load Capacity 30,000 N

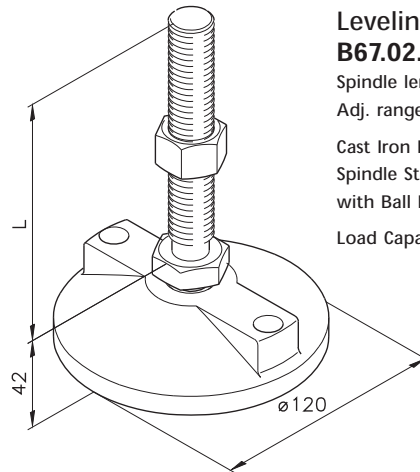
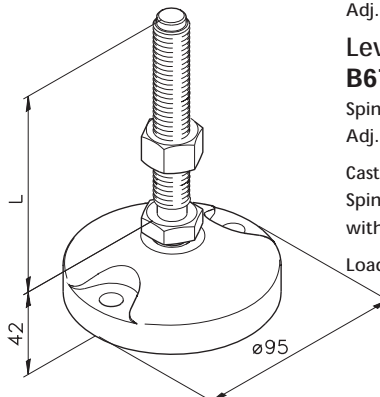

25 40 50 60

Leveling Pad GC M20 B67.02.030

Spindle length 120 mm,
Adj. range 80 mm

Cast Iron Pad,
Spindle Steel Zn,
with Ball Base

Load Capacity 30,000 N

25 40 50 60

Leveling Pad GE M20 B67.02.033

Spindle length 100 mm,
Adj. range 60 mm

Leveling Pad GE M20 B67.02.034

Spindle length 150 mm,
Adj. range 100 mm

Cast Iron Pad,
Spindle Steel Zn

Load Capacity 100,000 N

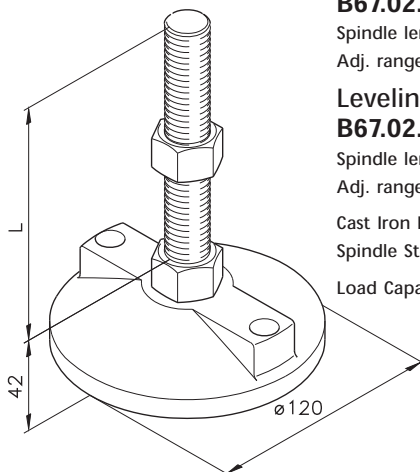

Floor Mounting

Support Brackets

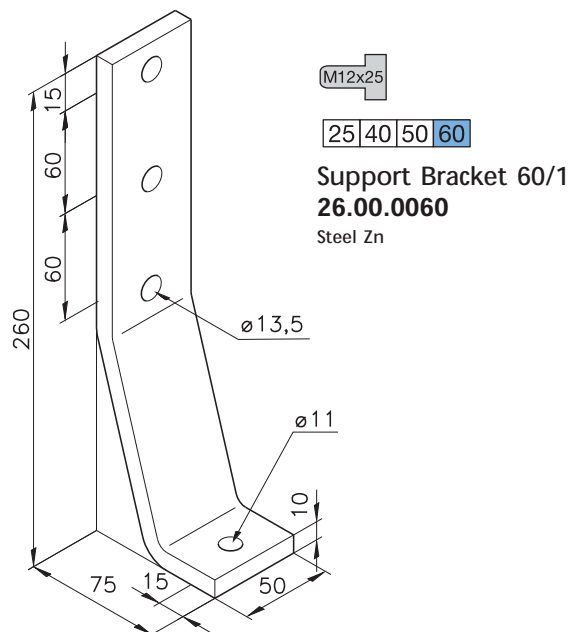
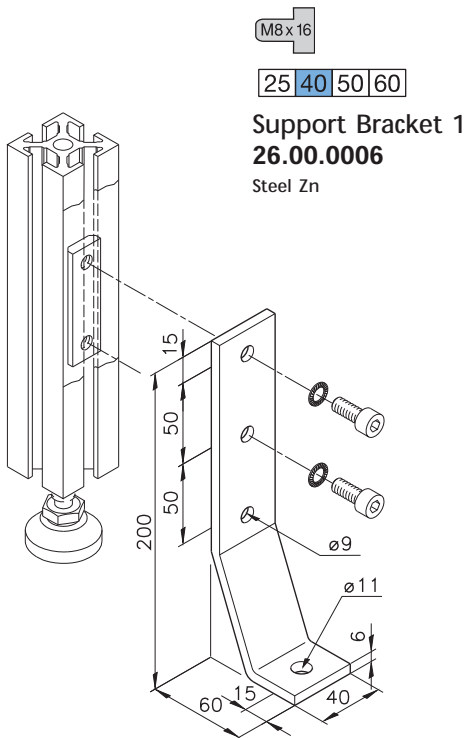
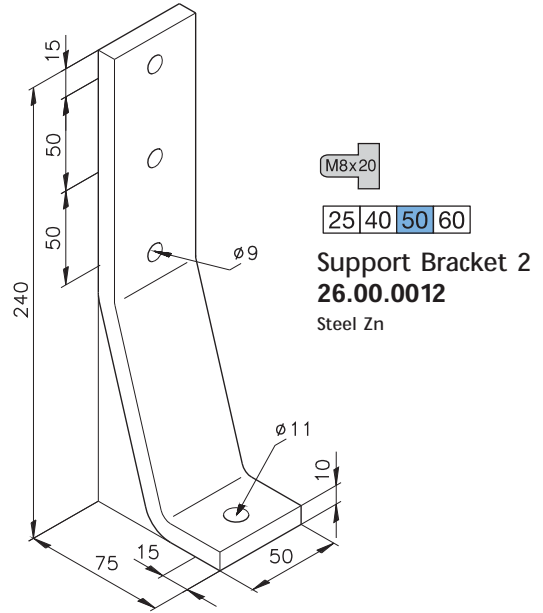

Accessory Components

Floor Mounting

Fixed and Swivel Casters Type A

The zinc plated steel housing of mk Casters Type A can be attached to either the profile T-slots or the profile ends. The casters feature rubber wheels for quiet travel and bearings for smooth operation. Swivel casters are supplied standard with a total-lock brake.

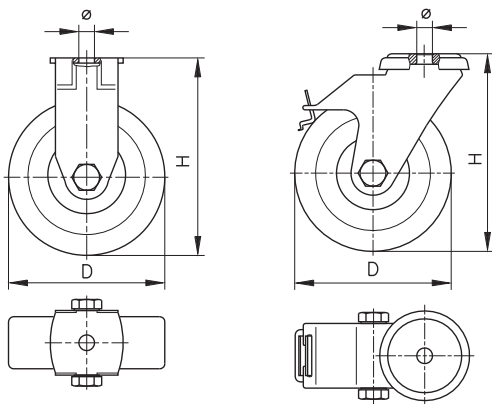

Fixed Caster (B)

| Designation | Wheel ø D (mm) | Tread width (mm) | Load capacity (kg) | Overall height H (mm) | Pre-drilled ø (mm) | Ident-No. |
|---------------|----------------|------------------|--------------------|-----------------------|--------------------|------------|
| BRA-VPA 50K | 50 | 18 | 400 | 69 | 10.5 | K106001040 |
| BRA-VPA 75K | 75 | 25 | 600 | 98 | 10.5 | K106001041 |
| BKRA-VPA 100K | 100 | 32 | 900 | 133 | 10.5 | K106001044 |
| BKRA-VPA 101K | 100 | 32 | 900 | 133 | 12.5 | K106001042 |
| BKRA-VPA 125K | 125 | 25 | 800 | 158 | 12.5 | K106001043 |

Swivel Caster (FI) with Total-Lock

| | | | | | | |
|------------------|-----|----|-----|-----|------|------------|
| LRA-VPA 50K FI | 50 | 18 | 400 | 69 | 10.5 | K106000140 |
| LRA-VPA 75K FI | 75 | 25 | 600 | 98 | 10.5 | K106000141 |
| LKRA-VPA 100K FI | 100 | 25 | 700 | 133 | 10.5 | K106000144 |
| LKRA-VPA 101K FI | 100 | 25 | 700 | 133 | 12.5 | K106000142 |
| LKRA-VPA 125K FI | 125 | 25 | 800 | 158 | 12.5 | K106000143 |



25 40 50 60

Pad Plate R3
50.02.0093

Al tumbled

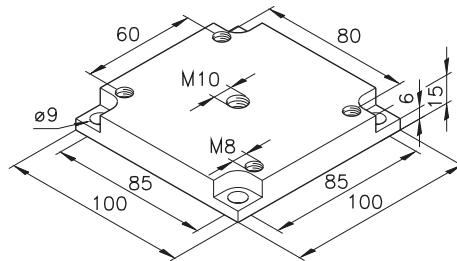

for mk 2005/mk 2011 and Rollers with predrilled \varnothing 10,5 mm hole or 80x60 mm hole pattern type B casters.



Floor Mounting

Fixed and Swivel Casters Type B

The zinc plated steel housing of mk Casters Type B are attached to profiles using the plates shown. The casters feature bearings and nylon wheels for smooth operation, and have a high load capacity. Swivel casters are supplied standard with a total-lock brake.

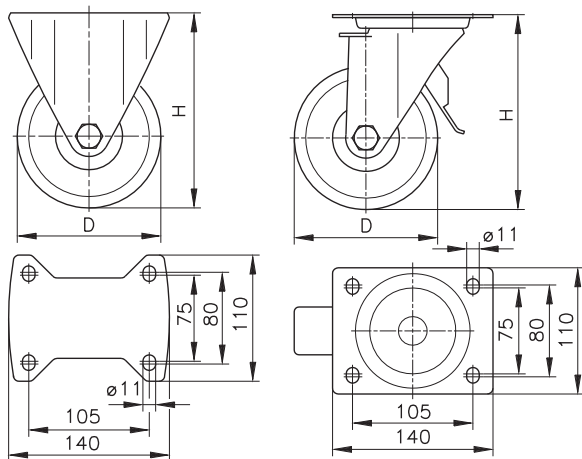

Fixed Caster (B)

| Designation | Wheel ø D (mm) | Tread width (mm) | Load capacity (kg) | Overall height H (mm) | Hole pattern mm/mm | Ident-No. |
|--------------|----------------|------------------|--------------------|-----------------------|--------------------|------------|
| BH-SPO 125K3 | 125 | 40 | 5000 | 165 | 105/80 | K106001045 |
| BH-SPO 125K1 | 125 | 40 | 5000 | 165 | 80/60 | K106001048 |

Swivel Caster (ST) with Total-Lock

| | | | | | | |
|-----------------|-----|----|------|-----|--------|------------|
| LH-SPO 125K 3ST | 125 | 40 | 5000 | 165 | 105/80 | K106000145 |
| LH-SPO 125K 1ST | 125 | 40 | 5000 | 165 | 80/60 | K106000148 |



DIN 7991

25 40 50 60

Pad Plate R1
50.02.0091

Al tumbled,

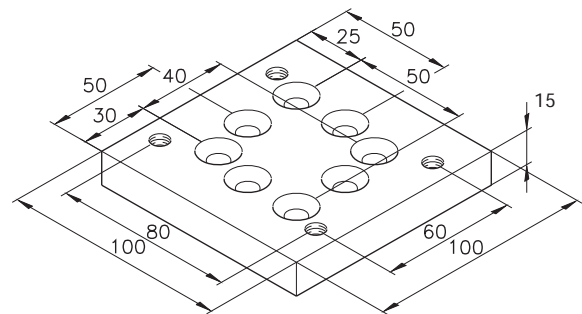

Universal plate used to attach casters with an 80/60 hole pattern. Use M8x25 FH-SHCS to attach plates to T-slots.

25 40 50 60

Pad Plate R4
50.02.0094

Al tumbled

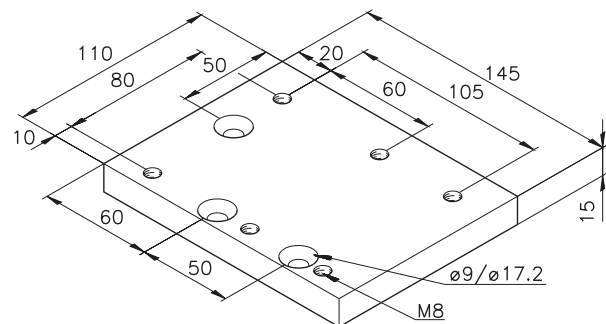

Accessory Components

Hoists

Hoists can be attached using M16/M20 pad plates or plates 4 and 5. An excellent method of moving equipment, the maximum carrying capacity shown applies for vertical loads only.

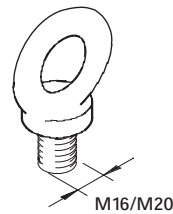

Eye Bolt
M16 DIN 580
D058016

C15 Zn
 Load Capacity 4,000 N

M20 DIN 580
D058020

C15 Zn
 Load Capacity 12,000 N

25 40 50 60

Plate 4 M20
50.09.0040

Steel Zn
 Load Capacity 12,000 N

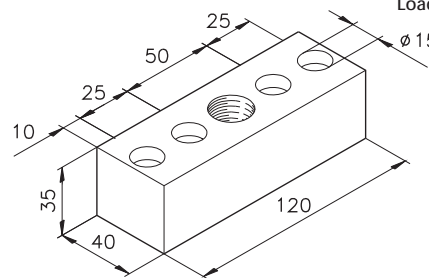

25 40 50 60

Plate 5 M20
50.09.0041

Steel Zn
 Load Capacity 12,000 N

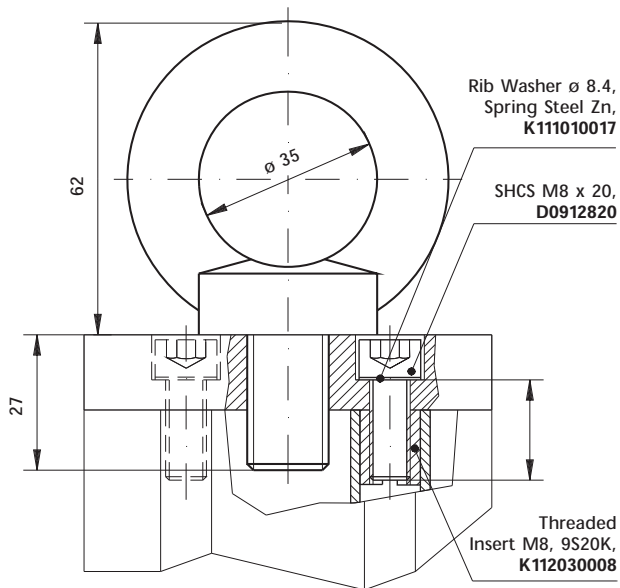
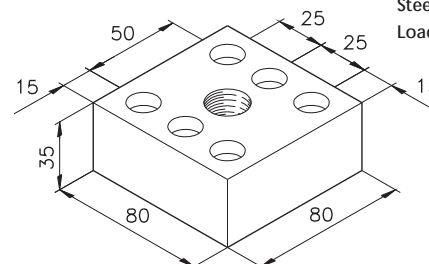

Operating elements

Handwheels

For attachment to spindles, for example, as shown on the linear positioning module. More information on linear positioning modules can be found in our Linear Technology catalog.



Handwheel K110020030

Duroplast Fs 31,
black,
Folding Handle

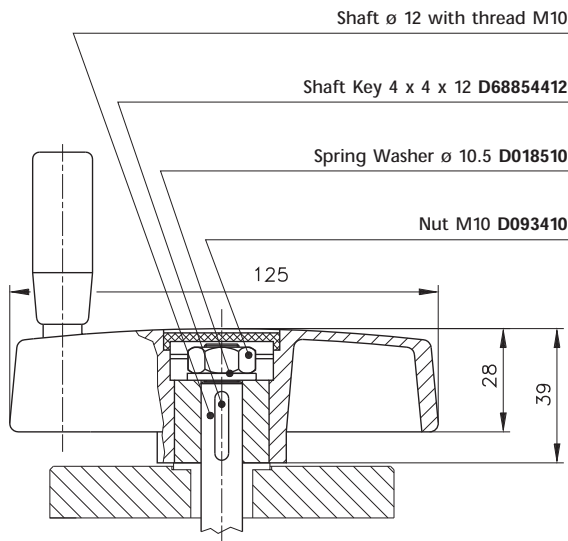
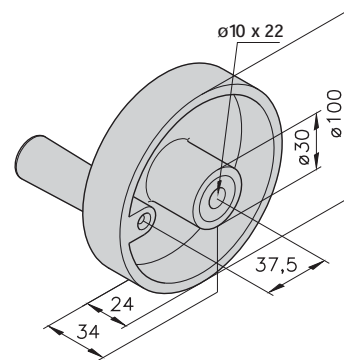

Handwheel K110020028

Duroplast Fs 31,
black

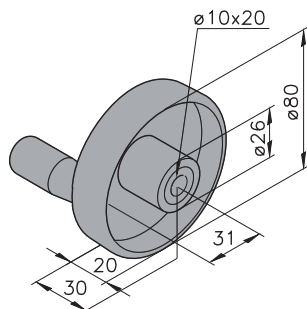

Handwheel K110020031

Duroplast Fs 31,
black,
Folding Handle

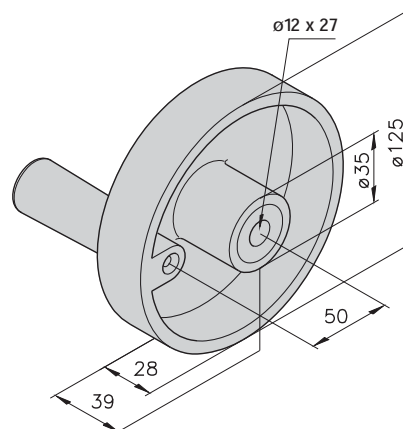

Accessory Components

Operating elements

Handles

The variety of handles are suitable for carrying, opening and closing, pushing of frames, doors, enclosures, windows, etc. Please order screws and nuts separately (varies by application).

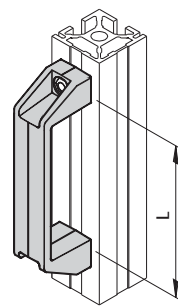
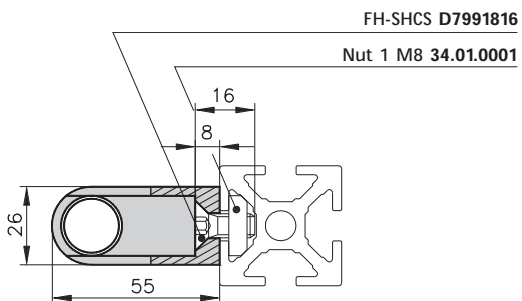
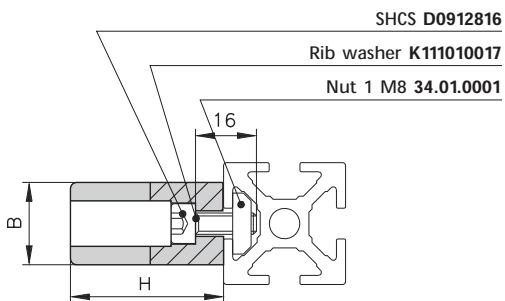
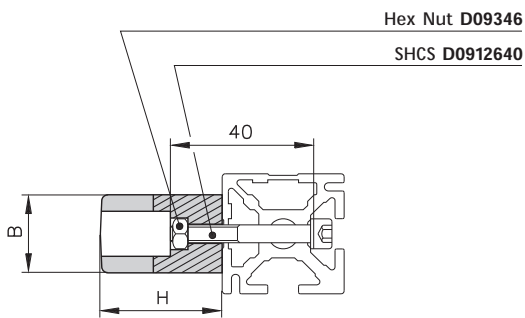

Handle
K110000021

PA-GF
L = 122 mm
B = 26 mm
H = 41 mm

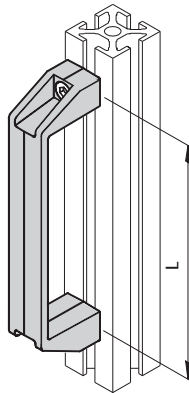

Handle
K110000020

PA-GF
L = 152 mm
B = 28 mm
H = 60 mm

Handle
K110000009

PP-GF
L = 117 mm
B = 26 mm
H = 41 mm

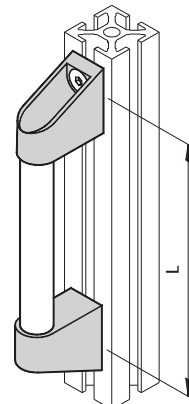

Handle
K110000010

PP-GF
L = 179 mm
B = 28 mm
H = 50 mm

Handle
K110000011

PA-GF, AI
L = 200 mm

Handle
K110000012

PA-GF, AI
L = 300 mm

Handle
K110000013

PA-GF, AI
L = 400 mm

Operating elements

Adjustable Handle

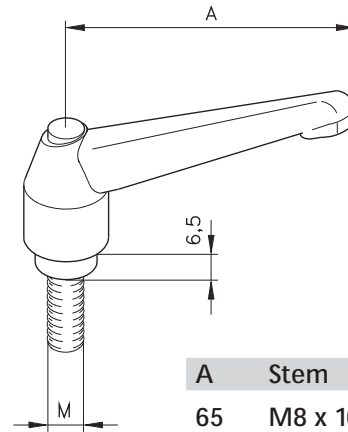

Adjustable Handle
Cast Zinc

| A | Stem | Ident-No. |
|----|---------|------------|
| 65 | M8 x 16 | K110030055 |
| 65 | M8 x 20 | K110030056 |
| 65 | M8 x 25 | K110030057 |

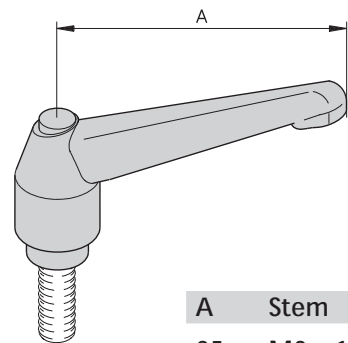
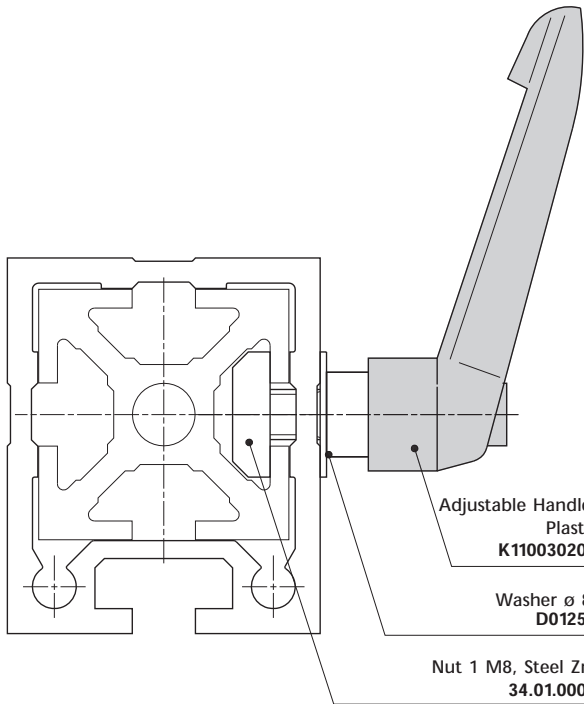

Adjustable Handle
Plastic

| A | Stem | Ident-No. |
|----|---------|------------|
| 65 | M6 x 15 | K110030200 |
| 65 | M6 x 20 | K110030201 |
| 65 | M6 x 25 | K110030202 |
| 65 | M8 x 16 | K110030204 |
| 65 | M8 x 20 | K110030205 |
| 65 | M8 x 25 | K110030206 |



Accessory Components

Door Components

Hinges

The variety of standard hinge arms allow combinations between the various profile series. A frame constructed using series 50 profiles, for example, can include a door built using series 25 profiles. Two or three-leaf hinges can be used, depending on whether tool-less removal of the door is to be an option or not. The three-leaf hinges feature glide bushings whereby continuous actuation is possible, even under high loads.

Mounting Example A

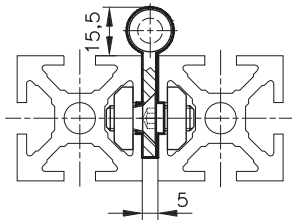

Mounting Example B

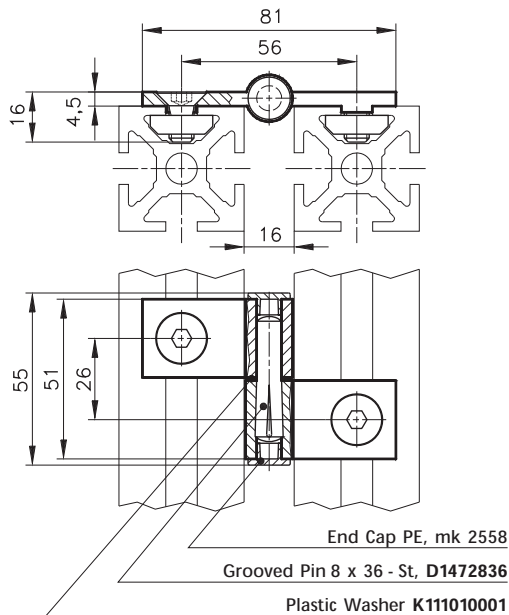

Combination Hinge 25-1/25-1

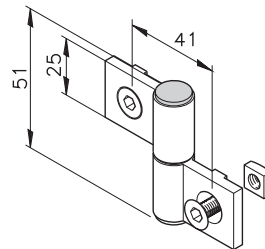
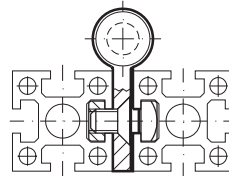

25 | 40 | 50 | 60

Hinge
25-1/25-1
B46.01.012
with mounting hardware

Combination Hinge 25-1/40-1

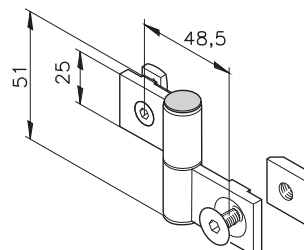
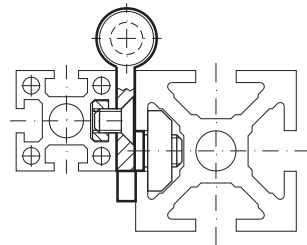

25 | 40 | 50 | 60

Hinge
25-1/40-1
B46.01.013
with mounting hardware

Door Components

Hinges

Combination Hinge 40-1/40-1
 and 40-1/40-7/40-1

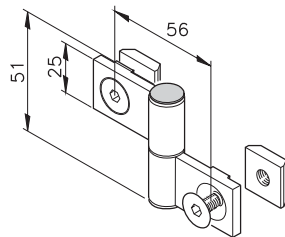
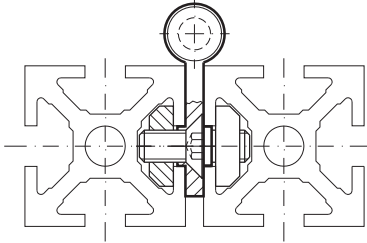

25 40 50 60

Hinge
 40-1/40-1
B46.01.010
 with mounting hardware

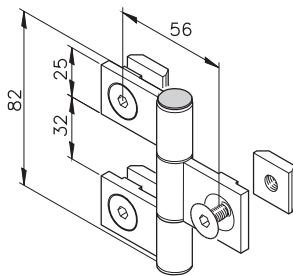

25 40 50 60

Hinge
 40-1/40-7/40-1
B46.01.030
 with mounting hardware

Combination Hinge 40-1/50-1

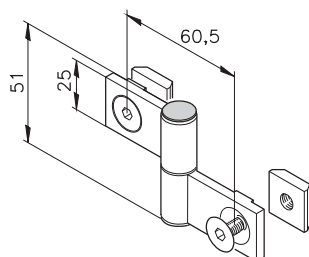
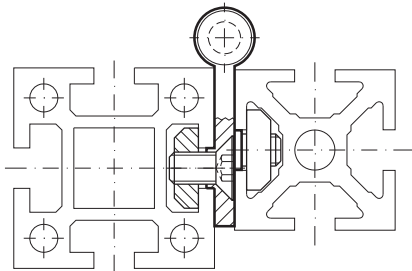

25 40 50 60

Hinge
 40-1/50-1
B46.01.011
 with mounting hardware

Combination Hinge 50-1/50-1
 and 50-2/50-2

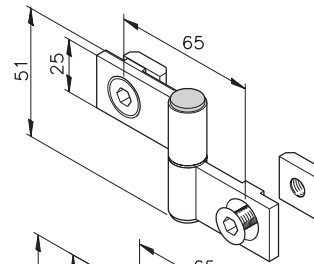
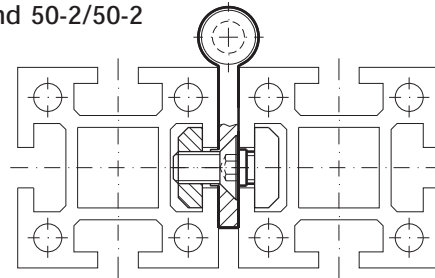

25 40 50 60

Hinge
 50-1/50-1
B46.01.001
 with mounting hardware

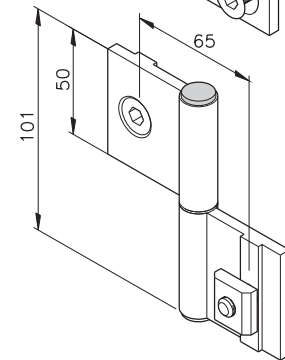

25 40 50 60

Hinge
 50-2/50-2
B46.01.002
 with mounting hardware

Combination Hinge 50-1/60-1

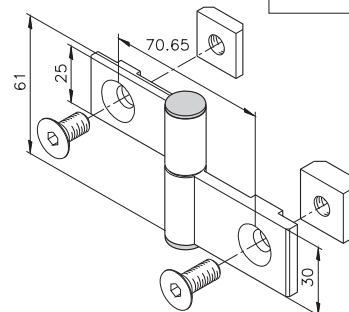
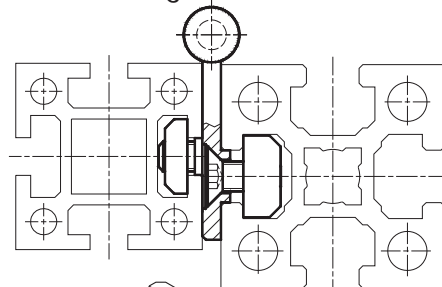

25 40 50 60

Hinge
 50-1/60-1
B46.01.064
 with mounting hardware

Accessory Components

Door Components

Hinges

Combination Hinge 60-1/60-1
and 60-1/60-7/60-1

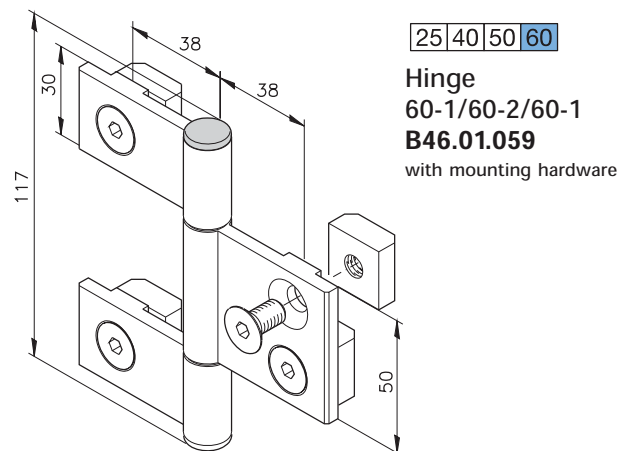
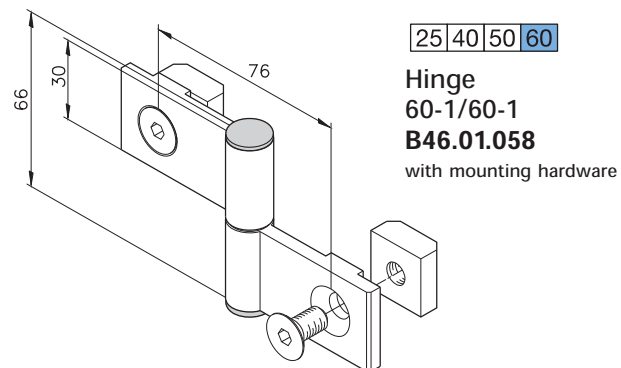
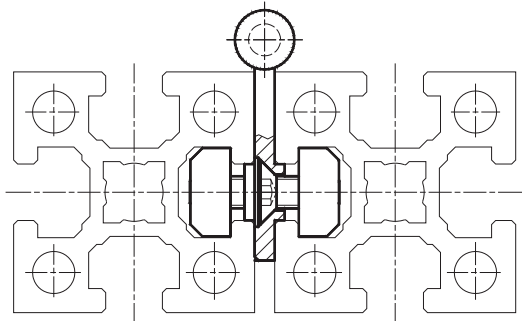

Combination Hinge 25-1/50-1

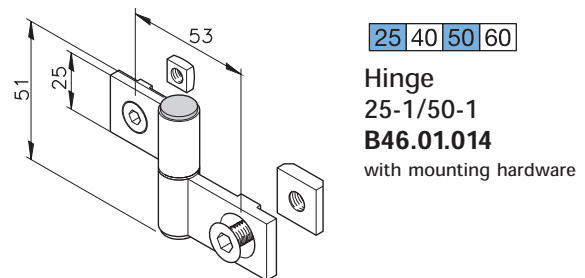
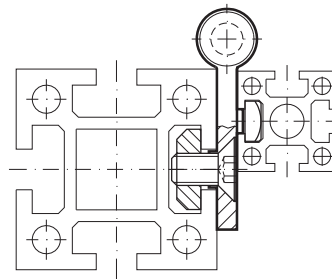

Combination Hinge 40-1/60-1

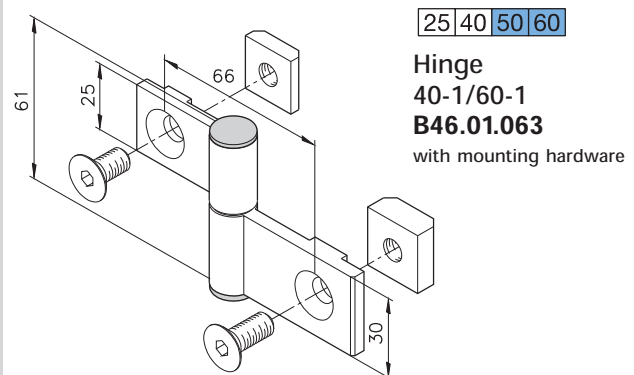
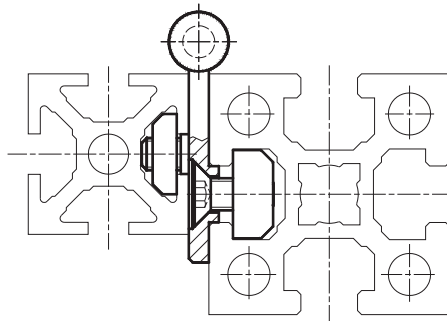

Door Components

Hinges

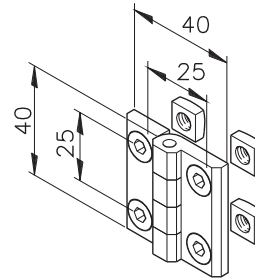

25 40 50 60

Hinge 25
B46.01.015

Hinge body
 Zinc, black,
 with mounting hardware

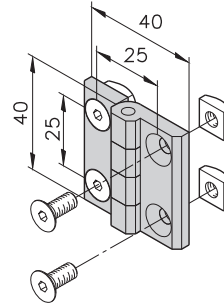

25 40 50 60

Plastic Hinge
B46.01.033

Hinge body plastic,
 with mounting hardware

FH-SHCS M5 x 10, D7991510

Nut M5, 25.50.0500

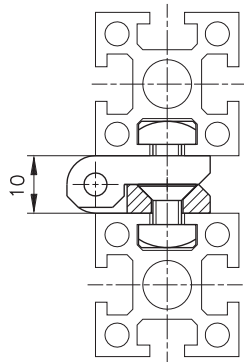
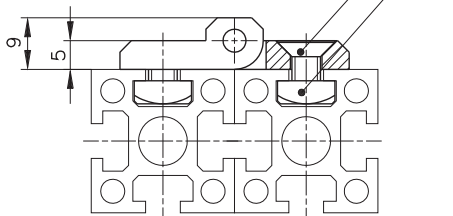

Accessory Components

Door Components

Hinges for Panels

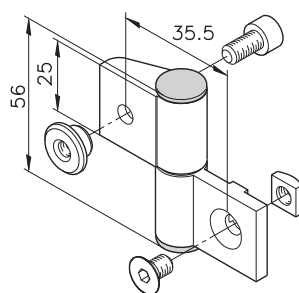
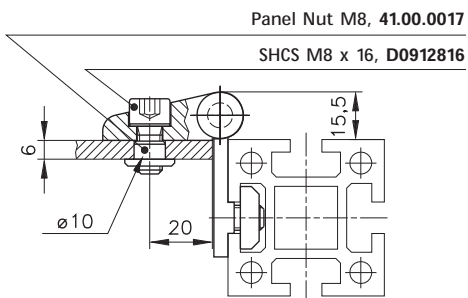
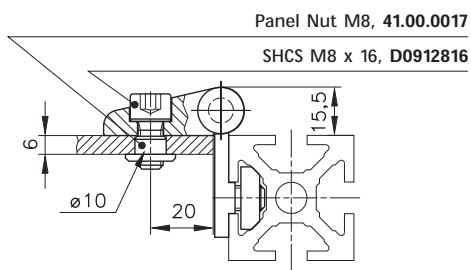
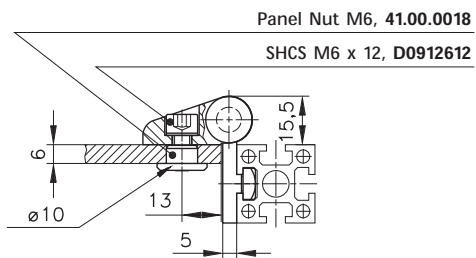

25 40 50 60

Hinge
25-1/25-3
B46.01.044
with mounting
hardware

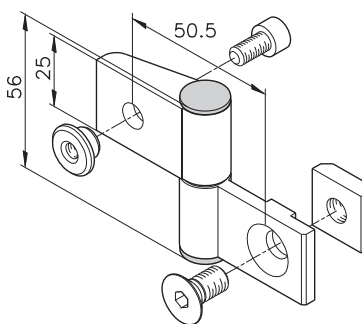

25 40 50 60

Hinge
40-1/40-3
B46.01.050
with mounting
hardware

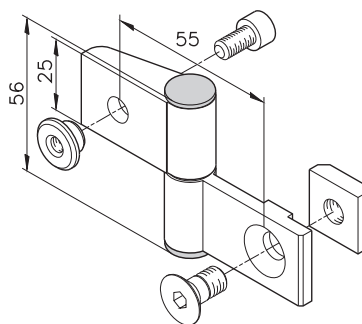

25 40 50 60

Hinge
50-1/40-3
B46.01.055
with mounting
hardware

Door Components

Ball latches

25 40 50 60

B68.02.101 for Door Gap 5 mm complete

B68.02.102 for Door Gap 24 mm complete

Nut 1, M6 **34.02.0008**, Steel Zn

FH-SHCS M6 x 12, **D7991612**

SHCS M6 x 12, **D0912612**

Ribbed Washer \varnothing 6.4,
K111010016, Steel Zn

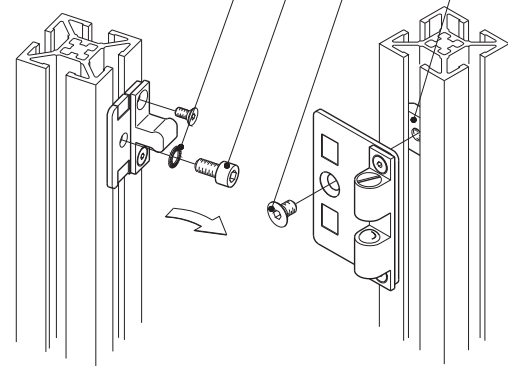

Ball latches for Door Gap 5 mm, **B68.02.101**

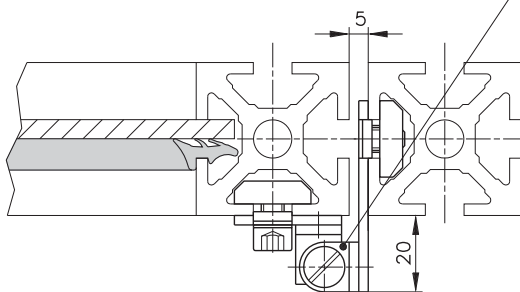

Ball latches for Door Gap 24 mm, **B68.02.102**

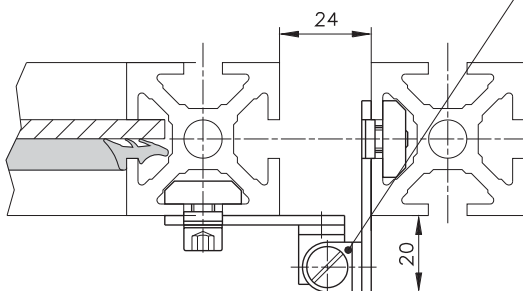

Door Stops

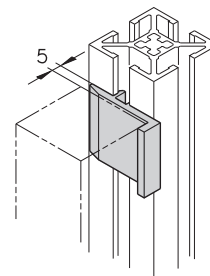

25 40 50 60

**Door Stop for
 Swing Doors**

(for 5 mm Door Gap)

22.90.0035

Plastic PE

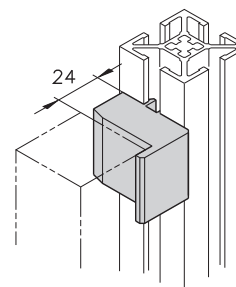

25 40 50 60

**Door Stop for
 Swing Doors**

(for 24 mm Door Gap)

22.92.0035

Plastic PE

Accessory Components

Door Components

External locks

Mounted to the door profile T-slot, the gap between the door and frame must be 24 mm. They are suitable for both swinging and sliding doors.



Swinging Door DIN-right

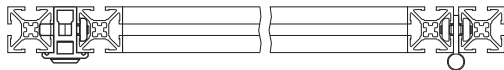

Swinging Door DIN-left

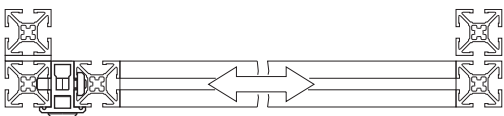
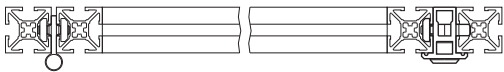

Catch B68.02.007

End Cap, mk 2507, PPN

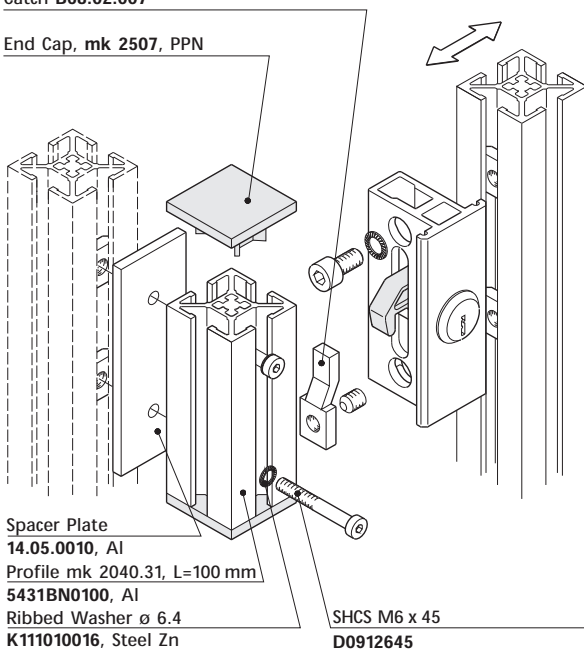

Spacer Plate
14.05.0010, Al
Profile mk 2040.31, L=100 mm
5431BN0100, Al
Ribbed Washer ϕ 6.4
K111010016, Steel Zn

SHCS M6 x 45
D0912645

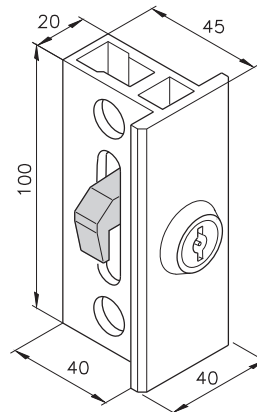

25 40 50 60

External
Double-Bit Lock
DIN-right
B68.02.017
DIN-left
B68.02.018

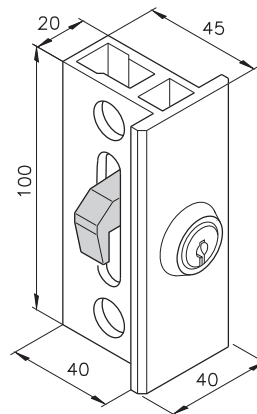

25 40 50 60

External
Cylinder Lock
DIN-right
B68.02.019
DIN-left
B68.02.020

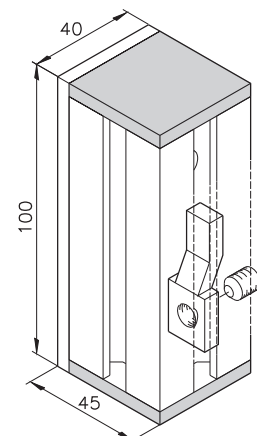

25 40 50 60

Frame Extension
with Catch
B68.06.005

Catch
B68.02.007

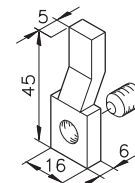

Door Components

Internal locks

The gap between the door and frame must be 5 mm.



25 | 40 | 50 | 60

Cylinder Lock
 complete as shown
B68.02.051

L = 42 mm

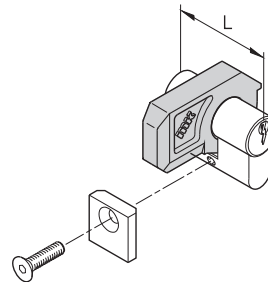

25 | 40 | 50 | 60

Cylinder Lock
 complete as shown
B68.02.052

L = 52 mm

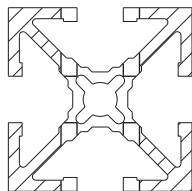
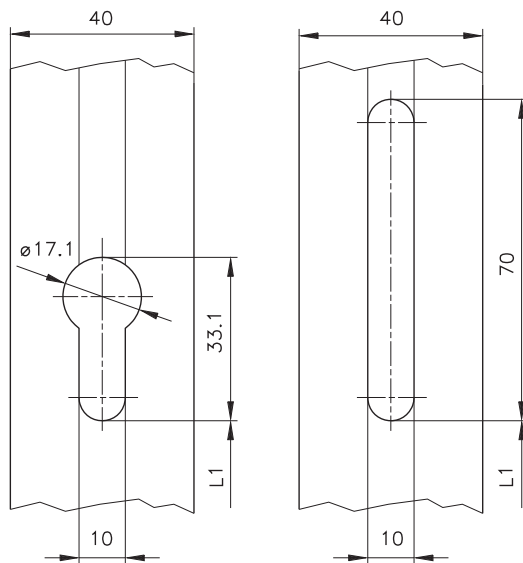

Profile Services

for Profile mk 2040.01

5401BC*

Please advise overall length
 and L1 dimension

for Profile mk 2040.40

5440BC*

Please advise overall length
 and L1 dimension

....* Profile length in mm

Accessory Components

Door Components

Slide Bolt

Used to lock swing doors at the top frame profile and/or at the floor. For this purpose, a guide angle must be mounted to the top frame profile; a lower side bolt is available for fastening to the floor. To hold the Lower Slide Bolt, an M8 thread must be formed in the vertical mk 2040.31 profile.



SHCS M8 x 20 D6912820

Nut 1 M8 34.01.0001

Guide Angle 76.03.0020, Al

Upper Slide Bolt
B68.02.152, Al

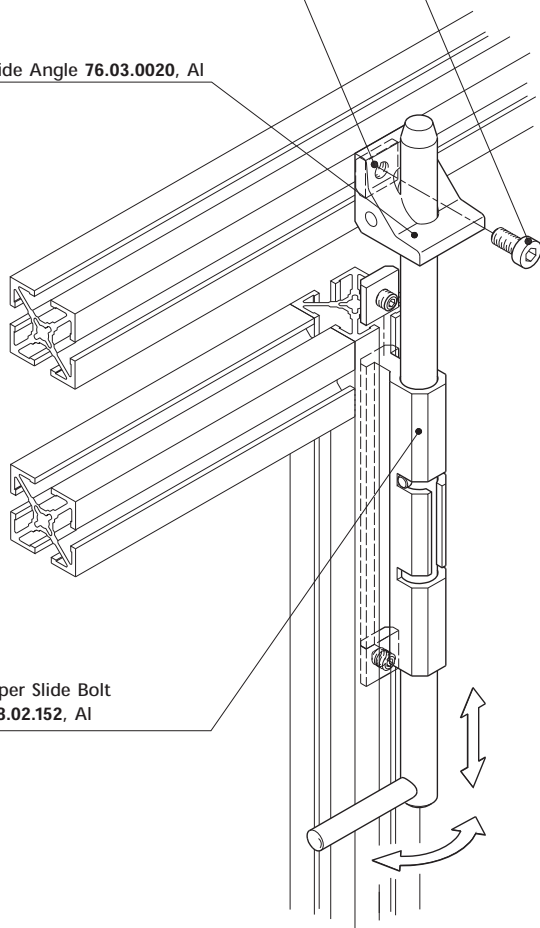

Upper Slide Bolt
B68.02.152

Al tumbled

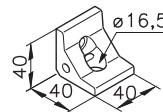

Guide Angle
76.03.0020

Al tumbled

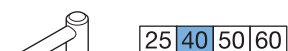

Lower Slide Bolt
B68.02.151

Al tumbled

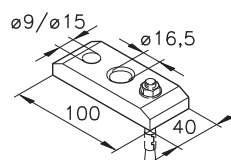

Anchor Plate
76.03.0018

Al

Door Components

Components for Sliding Doors

mk components include a cost-effective method for constructing sliding doors. The flanged roller assembly guides the door along the upper Profile T-slot while the Guide keeps the door oriented vertically. Once properly installed, the door is designed to be non-removable.

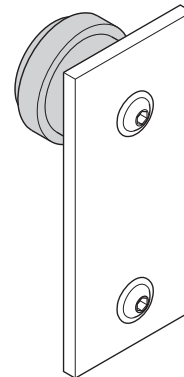
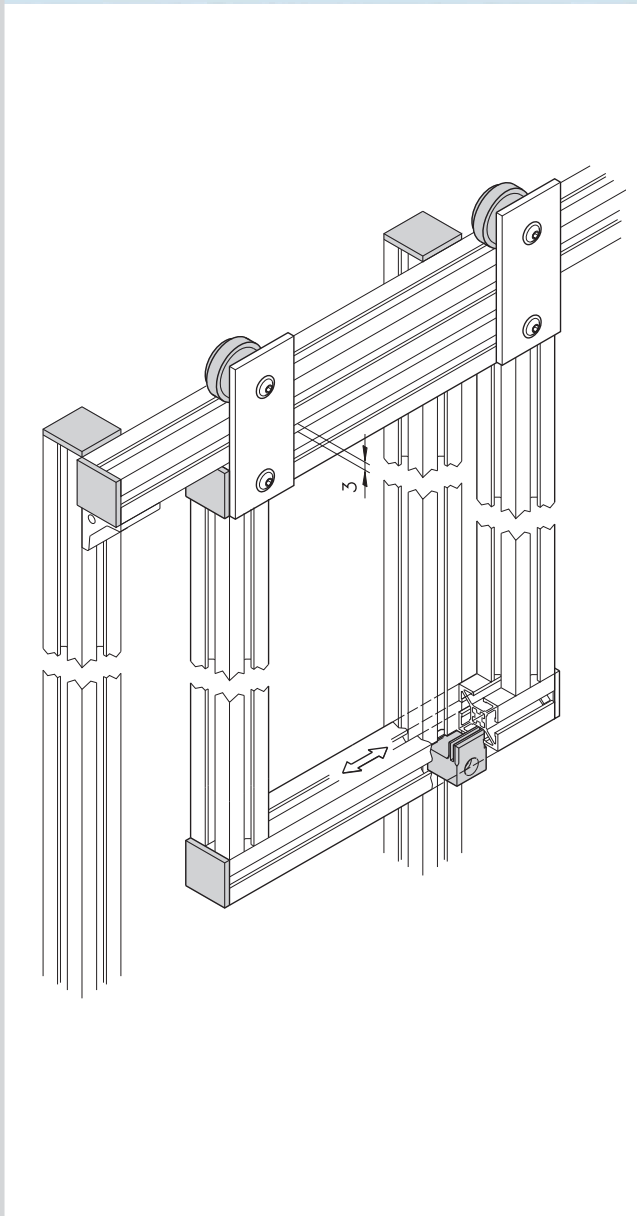

Roller Assembly
for Sliding Door
B68.11.003

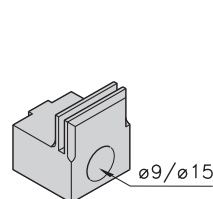

Guide for
Sliding Door
19.00.0005
Plastic black

Accessory Components

Closure and Seal Strips

Seal Strips firmly fix panels and/or plates which have been placed into the profile T-slots. These strips are designed for panel/plate thicknesses of 1.5-6 mm. Seal Strip mk 3011 (with lip) is used primarily for doors. Closure Strips prevent dirt and other contaminants from accumulating in the T-slots. The available colors can be used as accent stripes, or to identify a particular beam as containing compressed air, or wiring, for example.

Seal Strip mk 3030 closes floor gaps of 5-25 mm. As shown below, the height of this strip can be adjusted by peeling off pieces to the desired height. For shown stock lengths of over 2m, any lengths may be ordered.

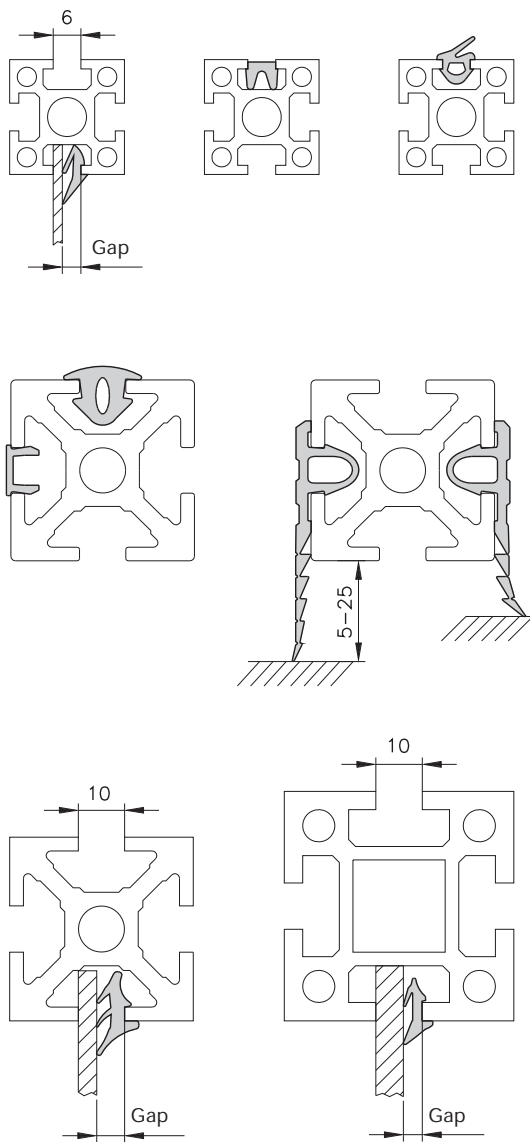

Closure Strips

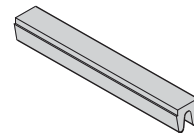

25 40 50 60

Closure Strip
mk 3026 black
PVC-P (soft),
Stock length 100 m

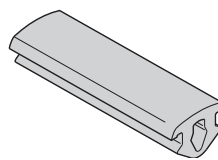

25 40 50 60

Closure Strip
mk 3010 black
PVC-P (soft),
Stock length 100 m

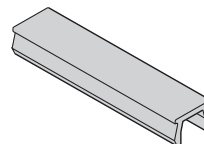

25 40 50 60

Closure Strip
mk 3012 black
mk 3013 grey
mk 3014 blue
mk 3015 yellow
mk 3016 green
mk 3017 red
mk 3019 silver
PVC-U (hard),
Stock length 2 m

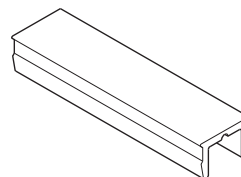

25 40 50 60

Profile **mk 2060.30**
0,14 kg/m
AlMgSi 0,5 F25

Stock length **60.30.2000**

Cut **60.30.***

Closure and Seal Strips

Closure and Seal Strips

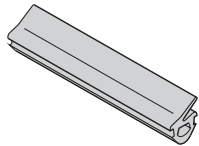

25 40 50 60

**Seal Strip
mk 3025** black
TPE, Stock length 50 m

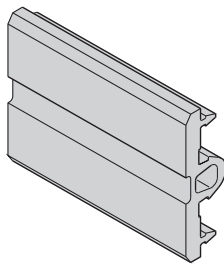

25 40 50 60

**Closure Strip
mk 3032** black
TPE, Stock length 25 m
for Profiles with
closed T-slots

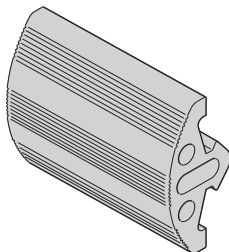

25 40 50 60

**Closure Strip
mk 3035** black
mk 3036 grey
PVC-P (soft),
Stock length 25 m

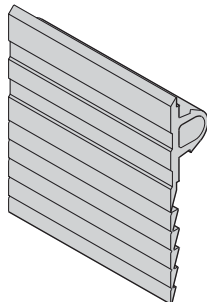

25 40 50 60

**Seal Strip
mk 3030** black
TPE, Stock length 40 m

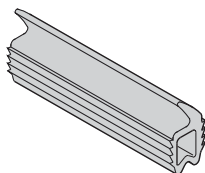

25 40 50 60

**Seal Strip
mk 3011** black
PVC, Stock length 200 m

Seal Strips

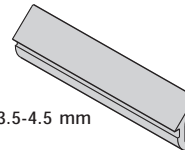

25 40 50 60

**Seal Strip
mk 3027** black
TPE, Stock length 300 m
for Gap 3.5-4.5 mm

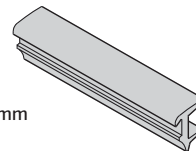

25 40 50 60

**Seal Strip
mk 3033** black
TPE, Stock length 200 m
for Gap 4 mm

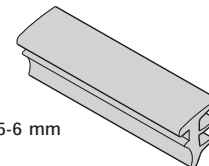

25 40 50 60

**Seal Strip
mk 3020** black
EPDM, Stock length 200 m
for Gap 5-6 mm

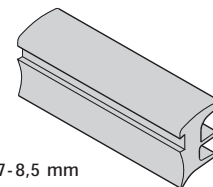

25 40 50 60

**Seal Strip
mk 3021** black
EPDM, Stock length 200 m
for Gap 7-8,5 mm

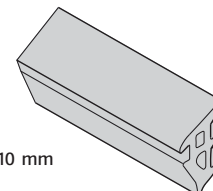

25 40 50 60

**Seal Strip
mk 3023** black
EPDM, Stock length 200 m
for Gap 10 mm

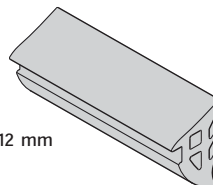

25 40 50 60

**Seal Strip
mk 3024** black
EPDM, Stock length 200 m
for Gap 12 mm

Accessory Components

Paneling and Accessories

Paneling

The paneling shown here can be used with all frames and doors shown in this catalog. When ordering, please advise all relevant frame dimensions for confirmation.

Metal panels painted per your specifications.

Paneling Material and Cuts

| Material | Color | Sheet Size | Thickness | Ident-No. Material | Ident-No. Cut 1) |
|---------------|-------------|----------------|------------|----------------------------|------------------|
| Acrylic | clear | 3050 x 2050 mm | 4 mm | K01D211004 ¹⁾ | 50.15.6014 |
| | | 3050 x 2050 mm | 5 mm | K01D211005 ¹⁾ | 50.15.6000 |
| | | 3050 x 2050 mm | 6 mm | K01D211006 ¹⁾ | 50.15.6001 |
| | | 4' x 8' | 1/4" | P90.05.001 ²⁾ | |
| Polycarbonate | clear | 3050 x 2050 mm | 4 mm | K01B211004 ¹⁾ | 50.15.6009 |
| | | 3050 x 2050 mm | 5 mm | K01B211005 ¹⁾ | 50.15.6002 |
| | | 3050 x 2050 mm | 6 mm | K01B211006 ¹⁾ | 50.15.6003 |
| | | 4' x 8' | 1/4" | P90.03.002 ²⁾ | |
| Polycarbonate | grey | 3050 x 2050 mm | 5 mm | K01B231005 ¹⁾ | 50.15.6002 |
| | | 3050 x 2050 mm | 6 mm | K01B231006 ¹⁾ | 50.15.6003 |
| | | 4' x 8' | 1/4" | P90.03.003 ²⁾ | |
| PETG | clear | 3050 x 2050 mm | 5 mm | K01P211005 ¹⁾ | 50.15.6019 |
| | | 3050 x 2050 mm | 6 mm | K01P211006 ¹⁾ | 50.15.6017 |
| Fencing Alu | | 3000 x 2000 mm | 40x40x4 mm | K00315122.40 ¹⁾ | 24.00.0000 |
| Fencing Steel | zinc plated | 3000 x 2000 mm | 40x40x4 mm | K00128222.40 ¹⁾ | 24.02.0000 |
| Trespa | silver | 5' x 10' | 1/4" | P90.08.001 ²⁾ | |

1) not in USA. 2) only in USA. * width and height in mm.

Paneling and Accessories

Paneling

Paneling Material and Cuts

| Material | Color | Sheet Size | Thickness | Ident-No. Material | Ident-No. Cut ¹⁾ |
|-----------------|--------------|----------------|--------------------|----------------------------|-----------------------------|
| Fencing Steel | black | 2000 x 1000 mm | 40x40x4 mm | K00128321.40 ¹⁾ | 24.05.0000 |
| | | 4' x 8' | 1"x1", 12 Ga. | P90.00.007 ²⁾ | |
| | yellow | 4' x 8' | 1/2"x1/2", 16 Ga. | P90.00.009 ²⁾ | |
| | | 4' x 8' | 1"x1", 12 Ga. | P90.00.008 ²⁾ | |
| | | 4' x 8' | 1/2"x1/2", 16 Ga. | P90.00.010 ²⁾ | |
| Alucobond | silver anod. | 2500 x 1250 mm | 4 mm | K00316222004 ¹⁾ | 50.15.4001 |
| | | | 4 / 2,5 mm gefalzt | | 50.15.3005 |
| | | 2500 x 1250 mm | 6 mm | K00316222006 ¹⁾ | 50.15.4002 |
| Dibond | white | 4' x 8' | 2 mm | P90.06.001 ²⁾ | |
| Steel | zinc plated | 2000 x 1000 mm | 1,5 mm | K00112121150 ¹⁾ | 07.28. * |
| | painted | 2000 x 1000 mm | 1,5 mm | K00112131150 ¹⁾ | 07.28. * |
| | zinc plated | 4' x 8' | 18 Ga. | P57.02.000 ²⁾ | |
| Stainless Steel | polished | 2000 x 1000 mm | 1,5 mm | K00205121150 ¹⁾ | 07.29. * |
| | | 4' x 8' | 20 Ga. | P57.01.000 ²⁾ | |
| Aluminum | silver anod. | 2000 x 1000 mm | 1,5 mm | K00305321150 ¹⁾ | 07.30. * |
| | | 2000 x 1000 mm | 2 mm | K00305321200 ¹⁾ | 07.33. * |
| Expanded PVC | black | 4' x 8' | 1/4" | P90.07.001 ²⁾ | |
| | blue | 4' x 8' | 1/4" | P90.07.002 ²⁾ | |
| | grey | 4' x 8' | 1/4" | P90.07.003 ²⁾ | |
| | white | 4' x 8' | 1/4" | P90.07.004 ²⁾ | |
| Alumalite | silver | 4' x 8' | 1/4" | P90.04.001 ²⁾ | |

Sizing

| Installed using | Width | Height | Installed using | Width | Height |
|-----------------|----------|----------|--------------------------|----------|----------|
| Seal Strip | LM+20 mm | LH+20 mm | Angle | LM | LH |
| Panel Clamp | LM-31 mm | LH-31 mm | Fencing w. Clamp Profile | LM+10 mm | LH+10 mm |
| Panel Block | LM | LH | Fencing | LM+20 mm | LH+20 mm |

1) not in USA. 2) only in USA.* width and height in mm.

Accessory Components

Paneling and Accessories

Paneling

... with Panel Blocks

Paneling requires \varnothing 9 mm holes at a distance of 10 mm from the edge. Panel Blocks are installed after completed frame assembly.

Paneling 2 - 6 mm

Nut M8, D09348

Block mk 2552, PA6 GF30

FBH-Screw
M8 x 12 K112010002

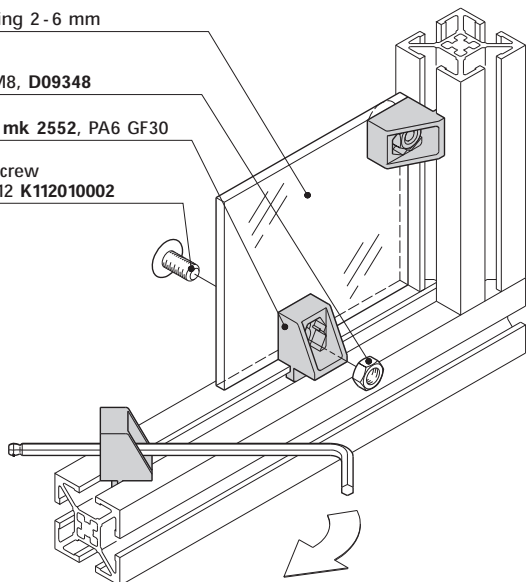

... with Panel Clamps

Panel clamps are installed after completed frame assembly.

Paneling (5 - 8 mm)

Panel Clamp
B34.01.001, PA6 GF30

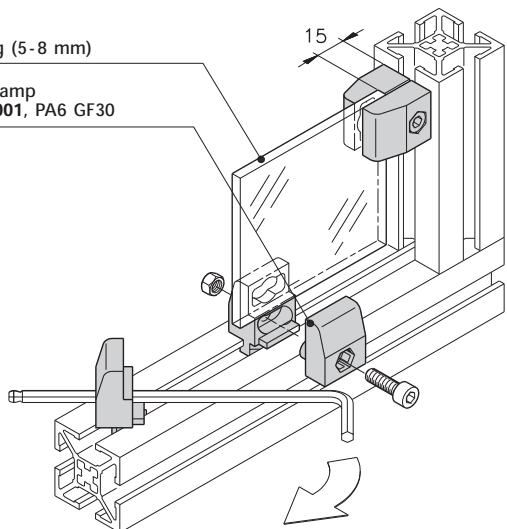

... with Angles

Panel clamps are used to mount 5-8 mm thick paneling onto assembled frames. For paneling attached directly to angles, panel blocks add additional support for lengths of over 600 mm.

Nut 1 M8 34.01.0001, Steel Zn

FBH-Screw
M8 x 16, K112010003

Cover 07.01.0005,
Steel Zn black

Angle with M8 thread

Steel (1.5 - 2 mm)

Ribbed Washer \varnothing 8.4
K111010017, Steel Zn

SHCS M8 x 16,
D0912816

Nut M8, D09348

Block mk 2552, PA6 GF30

FBH-Screw M8 x 12 K112010002

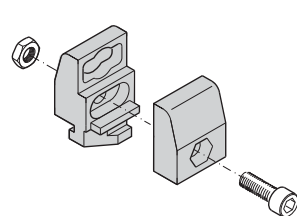
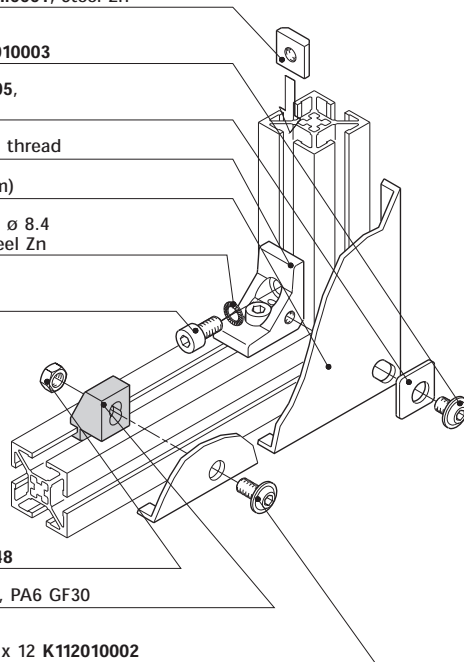

25 40 50 60

Panel Clamp 40
B34.01.001

PA6 GF30

25 40 50 60

Panel Clamp 50
B34.01.002

PA6 GF30

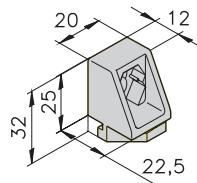

25 40 50 60

Panel Block
mk 2552

PA6 GF30

Paneling and Accessories

Paneling

... with Fence Clip System

The fence clip system is the most cost effective and fastest assembly. The fence clip is simply installed using a mallet.

Profile 40 x 40 mm 54.31.*

Fence Clip mk 2544

Fencing 40x40x4 (black powder coated) 24.05.**

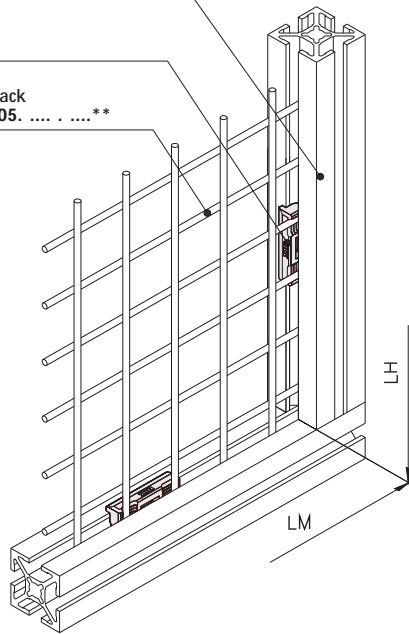

The clamp is designed for wire mesh fencing, thickness 4.

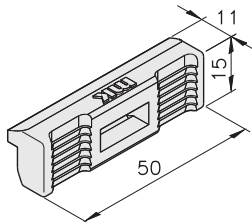

25 40 50 60

Fence Clip
mk 2544

... with Fence Clamp



The fence clamp is screwed into the profile slot using M8x20 screws and M8 nuts.

Post B69.65.000 H

Fence Clamp 30.00.0117

Fencing 40x40x4 (black powder coated) 2405CA**

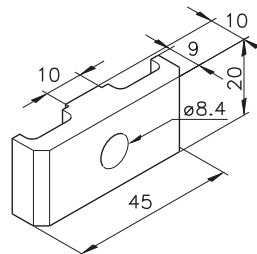
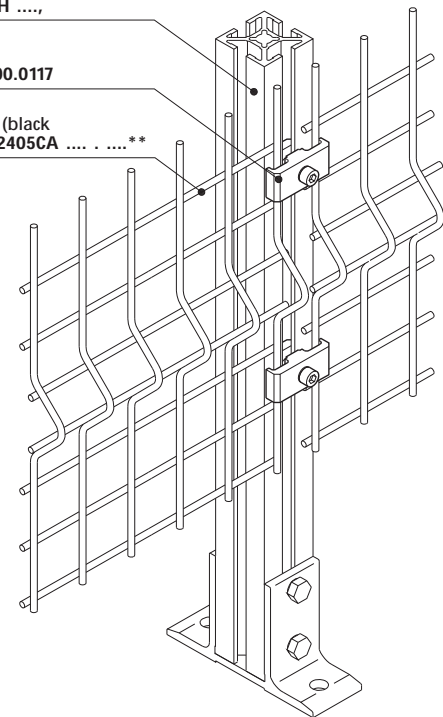

25 40 50 60

Fence Clamp
30.00.0117
 Al tumbled

Accessory Components

Paneling and Accessories

Paneling



Clamping profile for fencing

Clamping profiles are used when the aesthetics of the guarding are important as they frame the wire mesh completely. In addition, the clamping profiles securely hold the paneling around its entire perimeter.

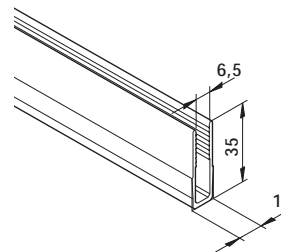

Profile mk 2040.60

0.30 kg/m

AlMgSi 0.5 F25

Stock length **54.60.6100**

Cut **54.60.***

Fence clamping

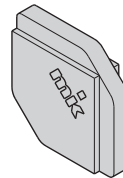
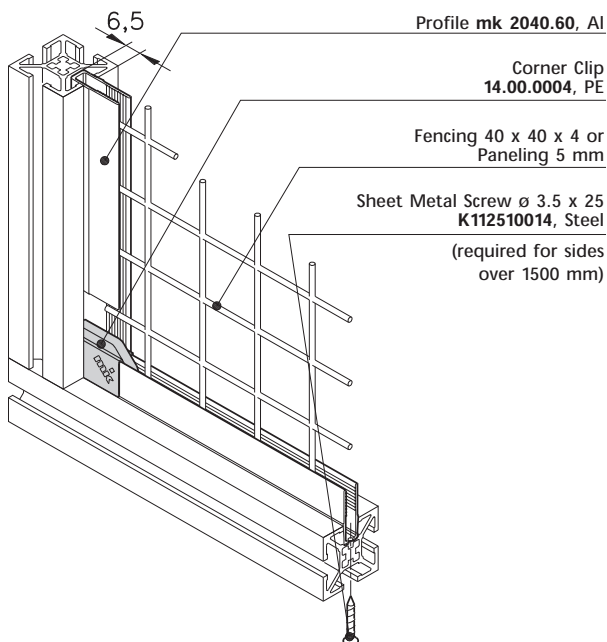

**Corner Clip
14.00.0004**

....* Profile length in mm

Paneling and Accessories

Paneling

with Windows

With the mk 2220 profile and the mk 3034 seal strip, a universal holder is available for 2 to 8 mm paneling. All series 40 and 50 structural profiles are suitable as support profiles.

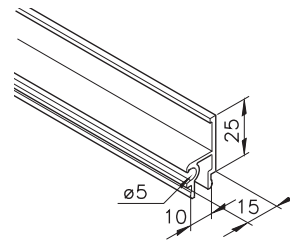
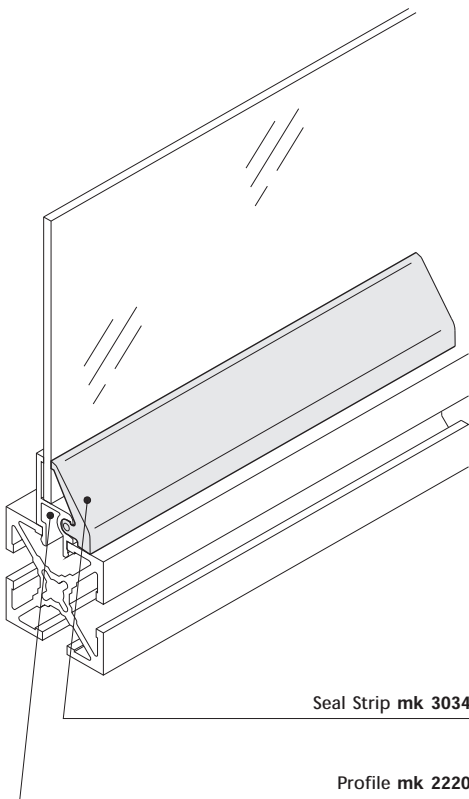

Profile mk 2220

0.32 kg/m
 AlMgSi 0.5 F25

Stock length **52.20.6100**

Cut **52.20.***

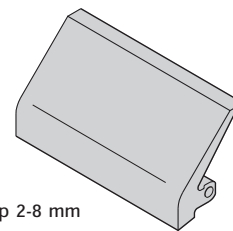

for Gap 2-8 mm

25 | 40 | 50 | 60

Seal Strip

mk 3034 black

for Paneling with mk 2220
 EPDM, Stock length 200 m

....* Profile length in mm

Accessory Components

Paneling and Accessories

Paneling

with Windows

Through various combinations of panel profiles and seal strips, panels of various thicknesses, can be installed within existing frames, even subsequently and without major effort or cost. These profiles are used primarily with 80 mm wide Series 40 structural profiles.

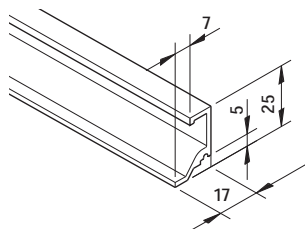

Profile mk 2040.81

0.28 kg/m
AlMgSi 0.5 F25

Stock length **54.81.5100**

Cut **54.81. ***

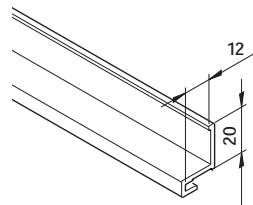

Profile mk 2040.59

0.26 kg/m
AlMgSi 0.5 F25

Stock length **54.59.5100**

Cut **54.59. ***

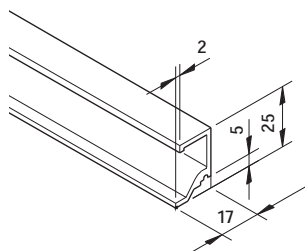

Profile mk 2040.82

0.31 kg/m
AlMgSi 0.5 F25

Stock length **54.82.5100**

Cut **54.82. ***

....* Profile length in mm

Examples

Panel width 6 mm

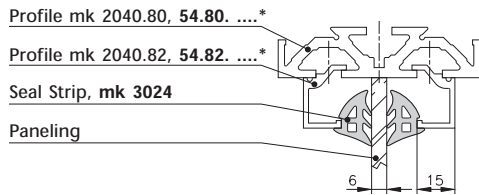

Panel width 18 mm

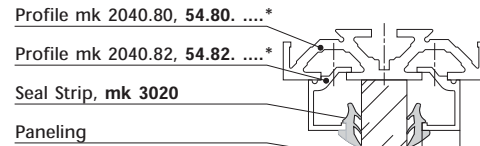

Panel width 8 mm

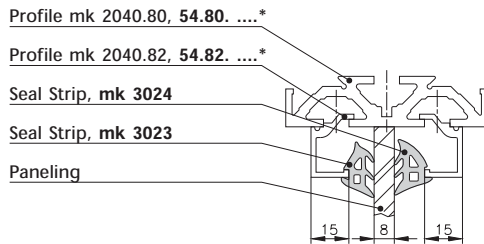

Panel width 20 mm

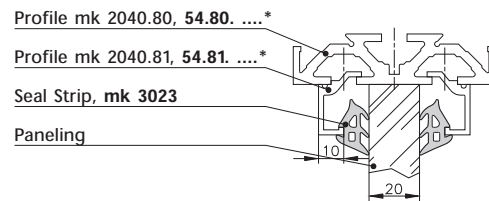

Panel width 10 mm

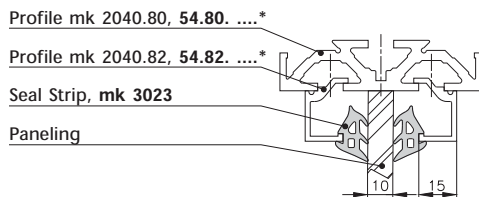

Panel width 30 mm

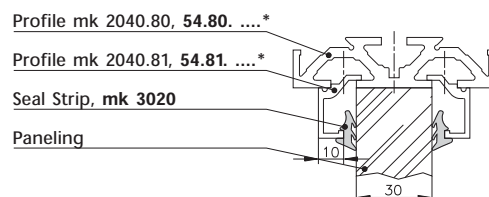

Panel width 12 mm

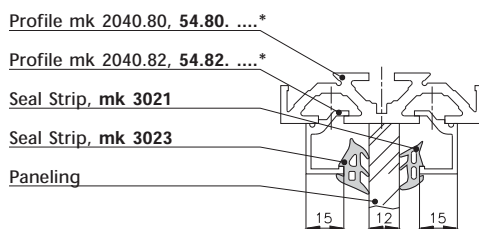

Panel width 50 mm

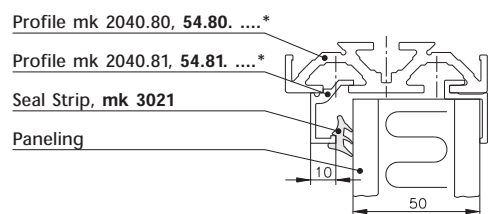

Panel width 15 mm

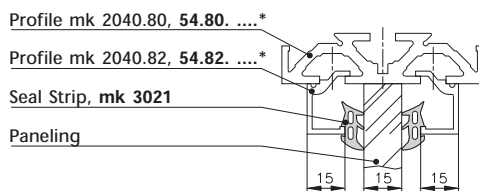

Panel width 74 mm

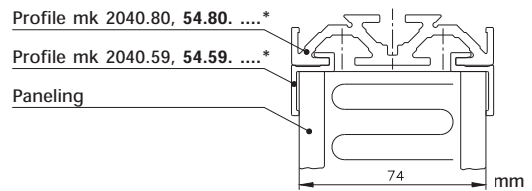

Accessory Components

Rollers

Mini-Rollers

Mini-Rollers are used, for example, for pallet runouts at workstations, transfer stations, etc. They can be attached to profiles of Series 40 and 50. Roller spacing depends on the product conveyed. Stock length of mk Wear Strips is 2000 mm.

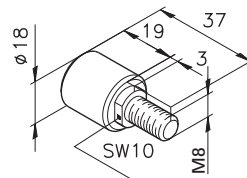

mk Mini-Roller
K101120001
Steel Zn

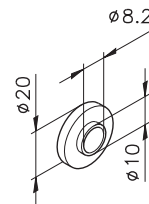

Step Washer
63.00.0011
Steel Zn

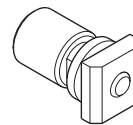

25 | 40 | 50 | 60

mk Mini-Roller
B60.04.002
with mounting hardware
max. radial load 80N

Wear Strip mk 1040.05, 21.05.*

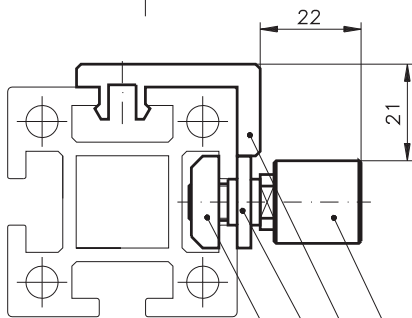
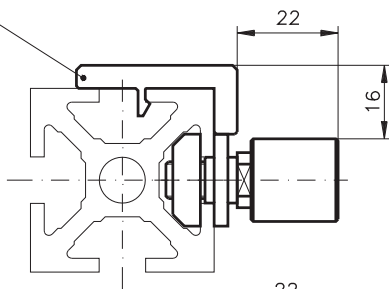

Nut 1 M8, 34.01.0001

Step Washer, 63.00.0011

Wear Strip mk 1008, 22.08.*

mk Mini-Roller, K101120001



Rollers

Carriage Rollers

Both roller types are used in combination with Series 50 profiles for simple guiding or transfer of heavy workpieces.

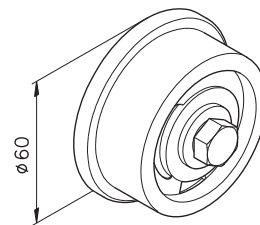
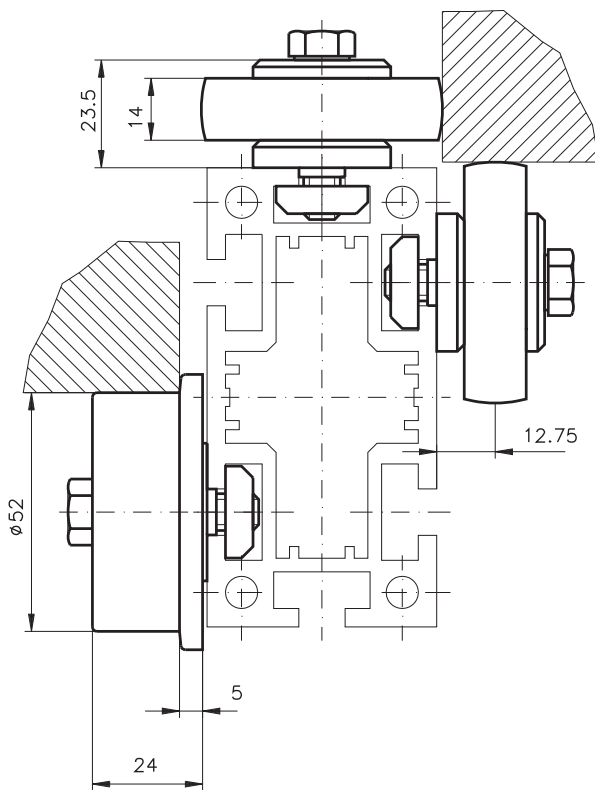

25 40 50 60

Flange Roller 1 **B60.00.001**

Roll blackened steel,
 complete with
 mounting hardware
 max. radial load 500N

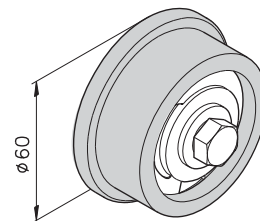

25 40 50 60

Flange Roller 2 **B60.00.002**

Roll POM,
 complete with
 mounting hardware
 max. radial load 200N

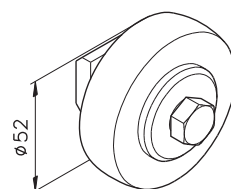

25 40 50 60

Roller **B60.01.001**

Roll blackened steel,
 complete with
 mounting hardware
 max. radial load 1000N



Accessory Components

Rollers

Carriage Rollers

Carriage Rollers can be used when frames or other equipment must travel in a linear direction, on either mk Profiles or tracks.

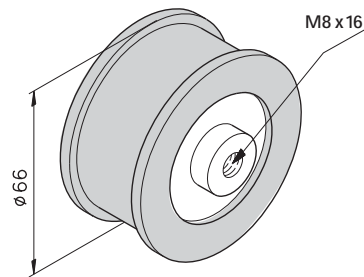
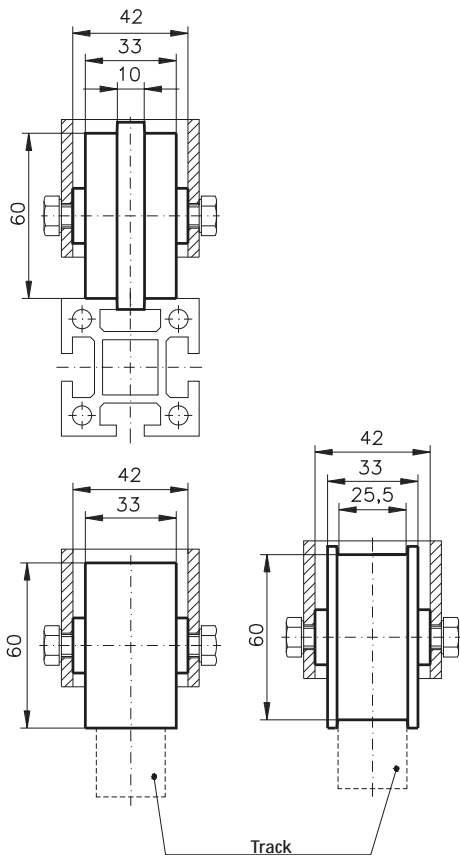

25 40 50 60

Flange Roller A1
B60.00.004

25 40 50 60

Flange Roller A1
B60.00.003

Roll Steel,
Bushing blacked steel,
max. radial load 1000N

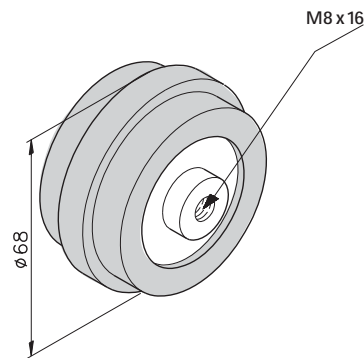

25 40 50 60

Guide Roller A2
B60.02.019

25 40 50 60

Guide Roller A2
B60.02.002

Roll POM,
Bushing blackened steel
max. radial load 200N

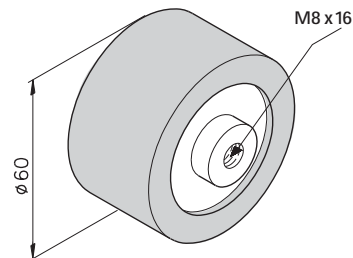

25 40 50 60

Roller A4
B60.01.005

25 40 50 60

Roller A4
B60.01.003

Roll POM,
Bushing blackened steel
max. radial load 200N

Pneumatic Components



Using pneumatic components, profiles mk 2040.02 and mk 2040.03 can be pressurized to provide compressed air at desired locations. This structural beam feature eliminates the need for additional plumbing in frames made using mk profiles. The pneumatic plates can be attached to the profile ends as well as their T-slots. The system is designed for a maximum pressure of 6 bar, or 90 psi. Further information on request.

Drill Fixtures see from page 227

Hose coupling

Ribbed Washer \varnothing 8.4, K111010017

O-ring \varnothing 12 x 2, K115010093

SHCS M8 x 25,
DIN 6912, D6912825

Nut 1 M8, 34.01.0001

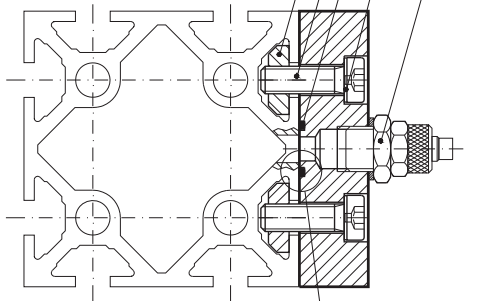

When attaching the distributor plate to the T-slot, the connection is sealed using O-rings.

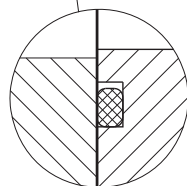

Hose coupling

Ribbed Washer \varnothing 8.4, K111010017

SHCS M8 x 25,
DIN 6912, D6912825

Seal

Threaded Insert M8,
9S20K, K112030008

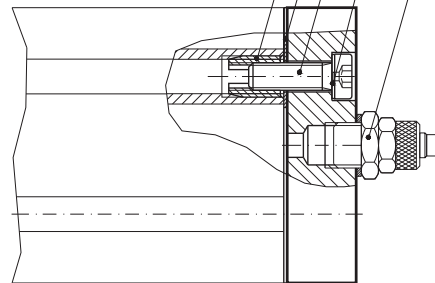

A seal ensures leak-proof attachment of plates to the profile ends.

Accessory Components

Pneumatic Components

End Plates



DIN 6912

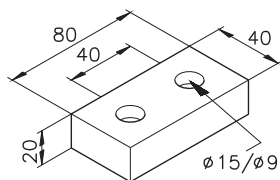

End Plate A
53.00.0100
Al tumbled

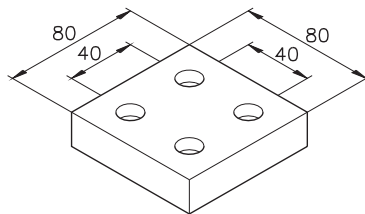

End Plate B
53.00.0101
Al tumbled

Supply Plates



Supply Plate A
G1/4"
53.00.0352

Supply Plate A
G1/2"
53.00.0200

Supply Plate A
NPT1/4"
53.00.0353

Supply Plate A
NPT1/2"
53.00.0210

Al tumbled

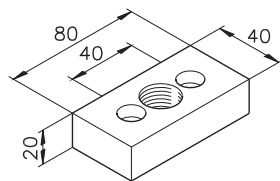

DIN 6912

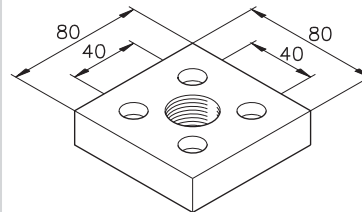

Supply Plate B
G1/2"
53.00.0201

Supply Plate C
G3/4"
53.00.0202

Supply Plate B
NPT1/2"
53.00.0211

Al tumbled



Distributor Plates



Distributor Plate
A18 G1/8"
53.00.0300

Distributor Plate
A14 G1/4"
53.00.0303

Distributor Plate
A14 NPT1/4"
53.00.0333
Al tumbled

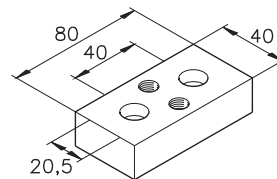

Distributor Plate
A28 G1/8"
53.00.0301

Distributor Plate
A24 G1/4"
53.00.0304

Distributor Plate
A24 NPT1/4"
53.00.0334

Al tumbled

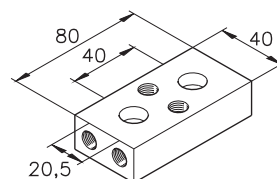

Pneumatic Components

Seals

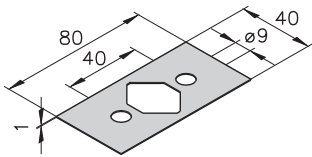

Seal A
53.01.0005

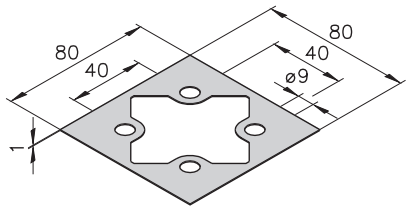

Seal B
53.01.0006

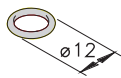

O-Ring \varnothing 12 x 2 mm
K115010093
 NBR 872

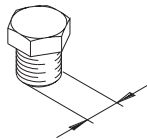

Closure Screw
 G1/4"
K502050426
 G1/2"
K502050428
 NPT1/4"
K502050451
 NPT1/2"
K502050450

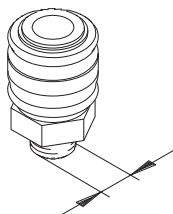

Coupling
 G1/4"
K502050700
 NPT1/4"
K502050706
 NPT1/2"
K502050705

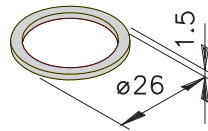

Coupling Seal
 G1/2"
K502050353

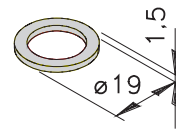

Coupling Seal
 G1/4"
K502050351

Accessory Components

Electric Components

Sensor Brackets



M8x12

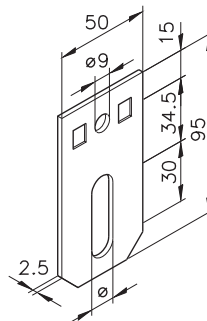

25 40 50 60

Sensor Bracket D
 ø 9 – 16.00.0016
 ø 13 – 16.00.0017
 ø 19 – 16.00.0018
 Steel Zn

M8x16

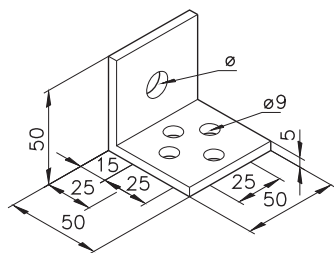

25 40 50 60

Sensor Bracket A
 ø 13 – 16.00.0000
 ø 19 – 16.00.0001
 R1/4" – 16.05.0011
 Al tumbled

25 40 50 60

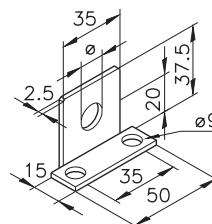

Sensor Bracket E
 ø 9 – 16.00.0026
 ø 13 – 16.00.0027
 ø 19 – 16.00.0028
 Steel Zn

25 40 50 60

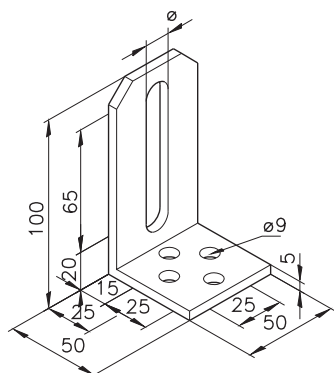

Sensor Bracket B
 ø 13 – 16.00.0006
 ø 19 – 16.00.0007
 Al tumbled

Electric Components

Wireways

Wireways offer an alternative to the usual cable trays. They are extremely functional and integrate neatly with mk profile systems. They can be installed at any time, requiring no tools. Cable clips are ideal for both temporary and permanent cable management and can be used either with or without the covers.

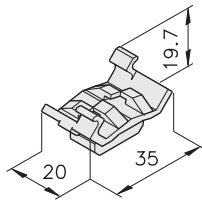
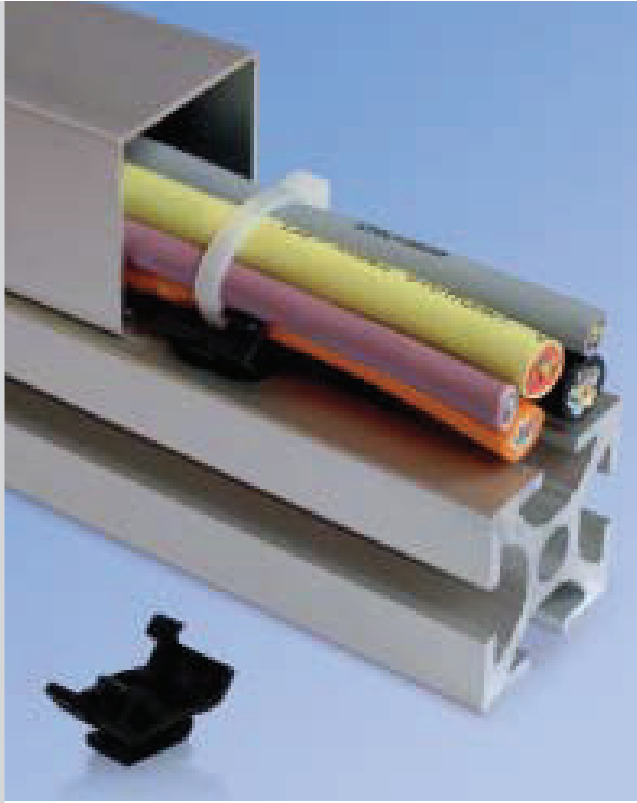

25 40 50 60

Clip 40
mk 2546
PA 6

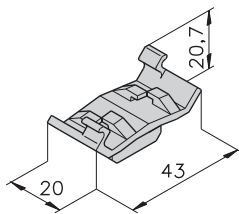

25 40 50 60

Clip 50
mk 2550
PA 6

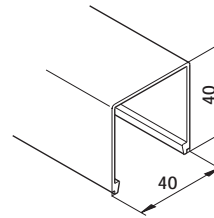

mk 2040.50

0.51 kg/m
AlMgSi 0.5 F25

Stock length **54.50.5100**

Cut **54.50. ***

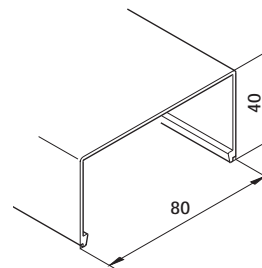

mk 2040.51

0.67 kg/m
AlMgSi 0.5 F25

Stock length **54.51.5100**

Cut **54.51. ***

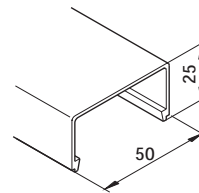

mk 2050

0.43 kg/m
AlMgSi 0.5 F25

Stock length **51.50.5100**

Cut **51.50. ***

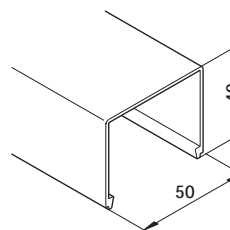

mk 2051

0.56 kg/m
AlMgSi 0.5 F25

Stock length **51.51.5100**

Cut **51.51. ***

Accessory Components

End Caps

End Caps of injection molded plastic (PPN 1060) cover the ends of the profiles and attach flush to the profile edges. The finish is matte black and add a pleasant aesthetic accent to frames. The end caps are simply pressed onto the profile.



Series 25

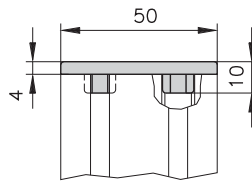

Series 40

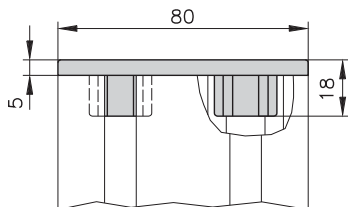

Series 50

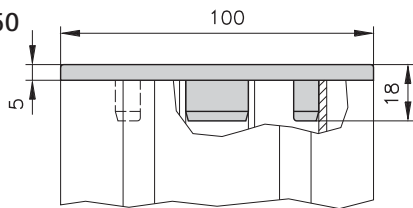

Series 60

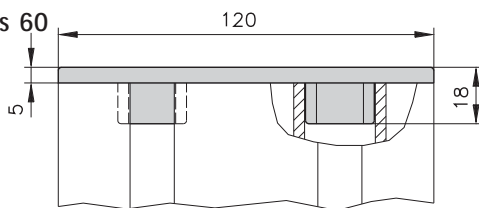

25 40 50 60

for Profile mk 2025.01
25.50.8000

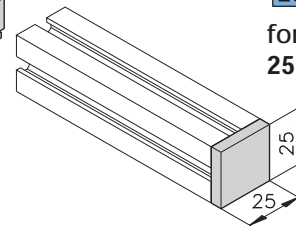

25 40 50 60

for Profile mk 2025.37
25.50.8004

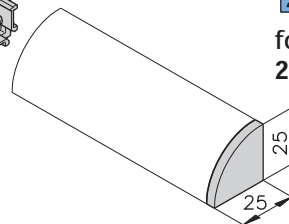

25 40 50 60

for Profile mk 2025.38
25.50.8005

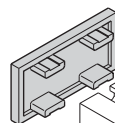
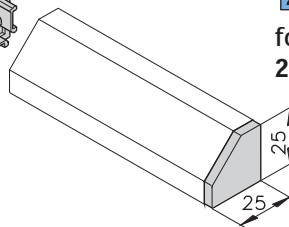

25 40 50 60

for Profile mk 2025.02
25.50.8001

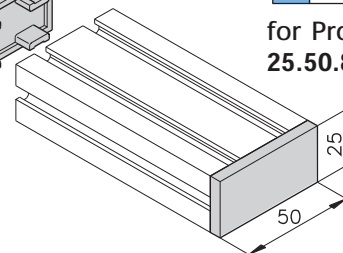

End Caps

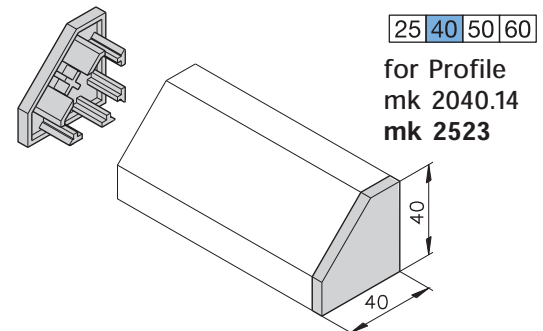
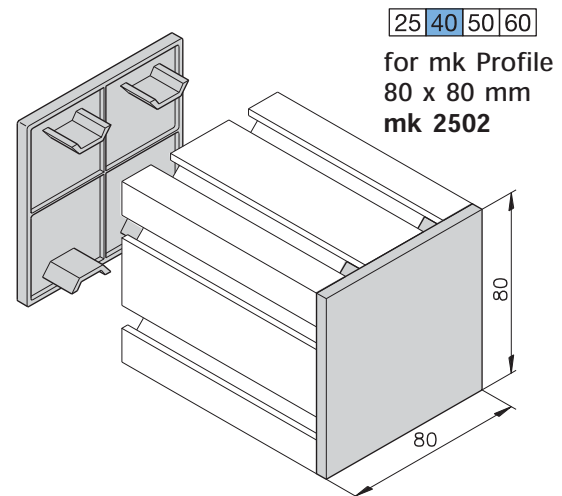
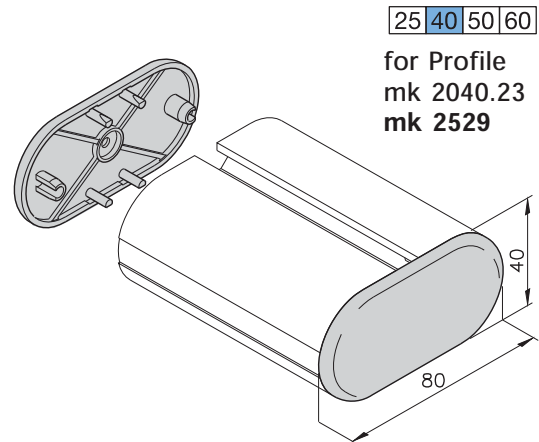
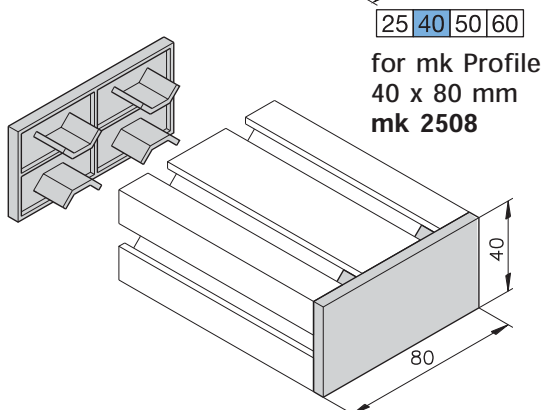
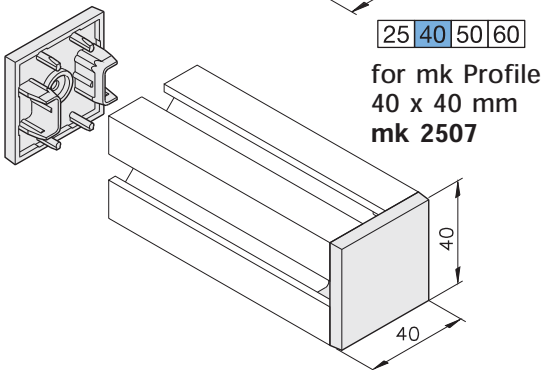
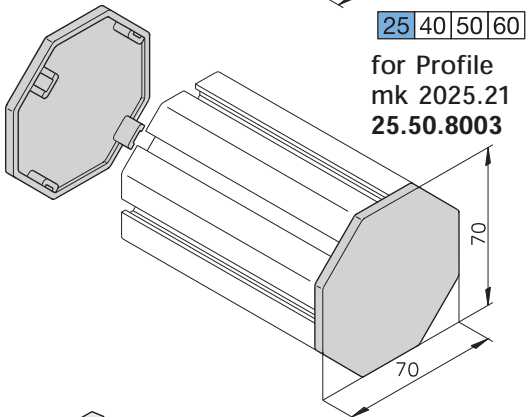
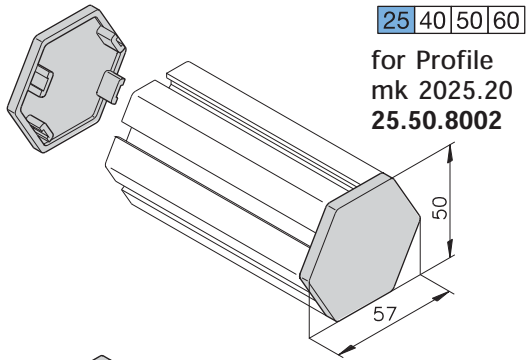

Accessory Components

End Caps

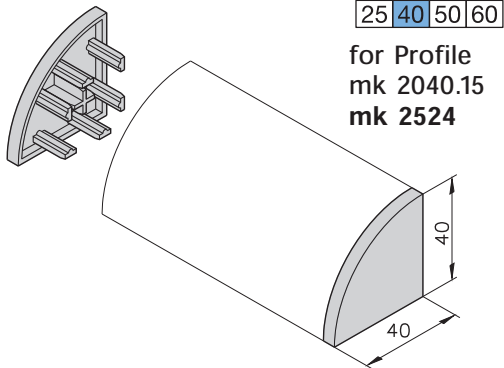

25 40 50 60
for Profile
mk 2040.15
mk 2524

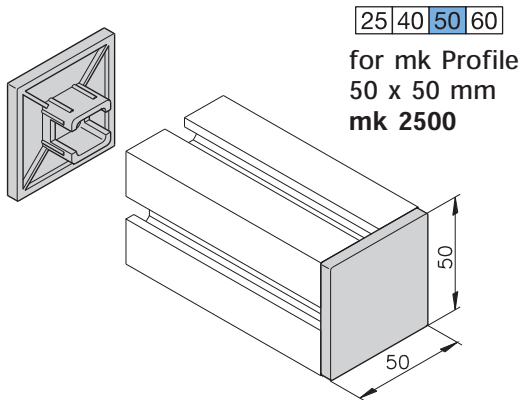

25 40 50 60
for mk Profile
50 x 50 mm
mk 2500

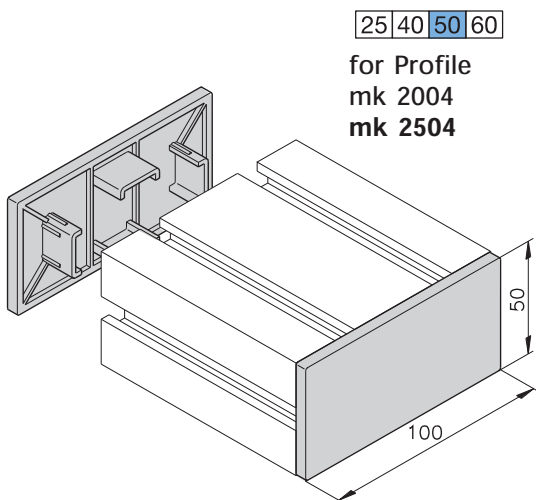

25 40 50 60
for Profile
mk 2004
mk 2504

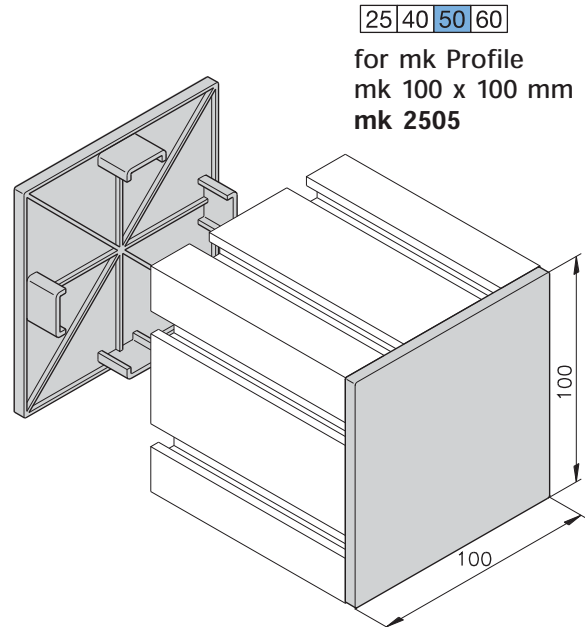

25 40 50 60
for mk Profile
mk 100 x 100 mm
mk 2505

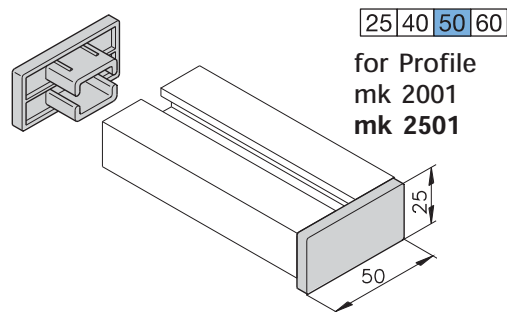

25 40 50 60
for Profile
mk 2001
mk 2501

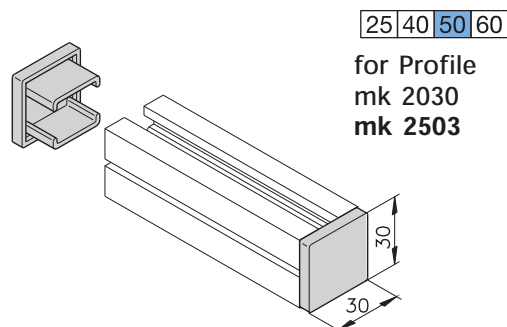

25 40 50 60
for Profile
mk 2030
mk 2503

End Caps

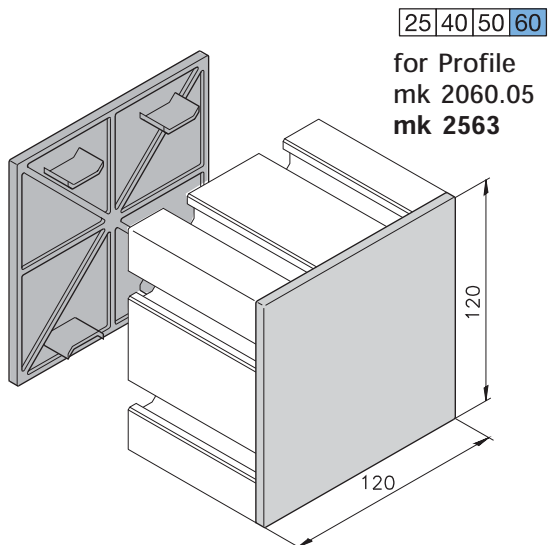
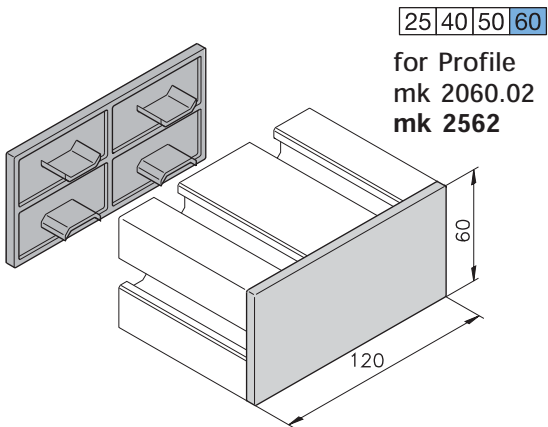
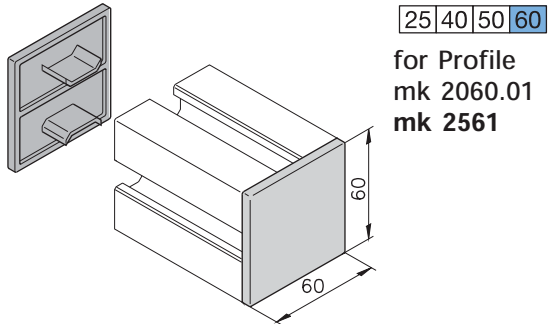

Larger profiles can be covered by using a combination of end caps. As shown below, profile mk 2040.05 can be capped using one each End Cap mk 2507 and mk 2508.

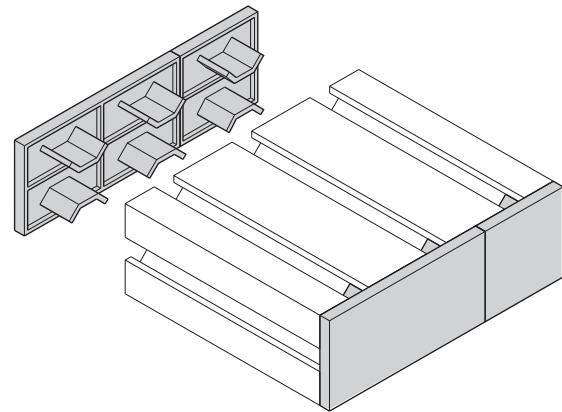

Accessory Components

Wear Strips

Slide- and Wear Strips from mk ensure low friction for a variety of applications. The Wear Strips are made with PE - UHMW (PE - 1000) and are available exclusively in stock lengths of 2000 mm.

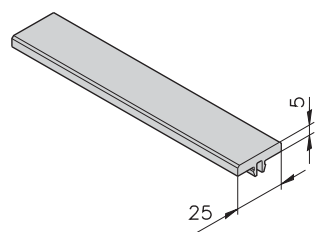
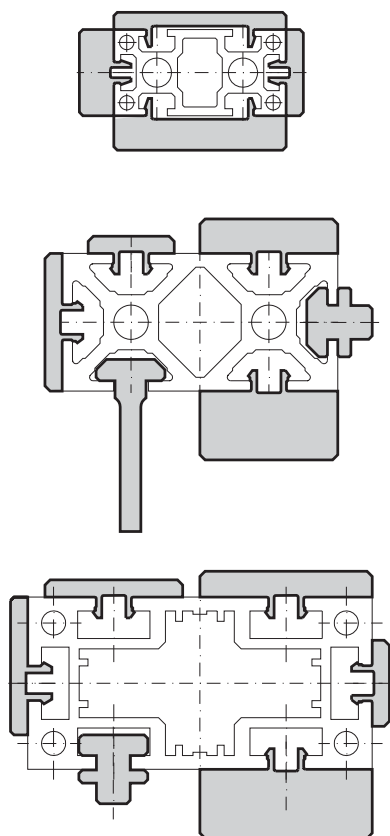
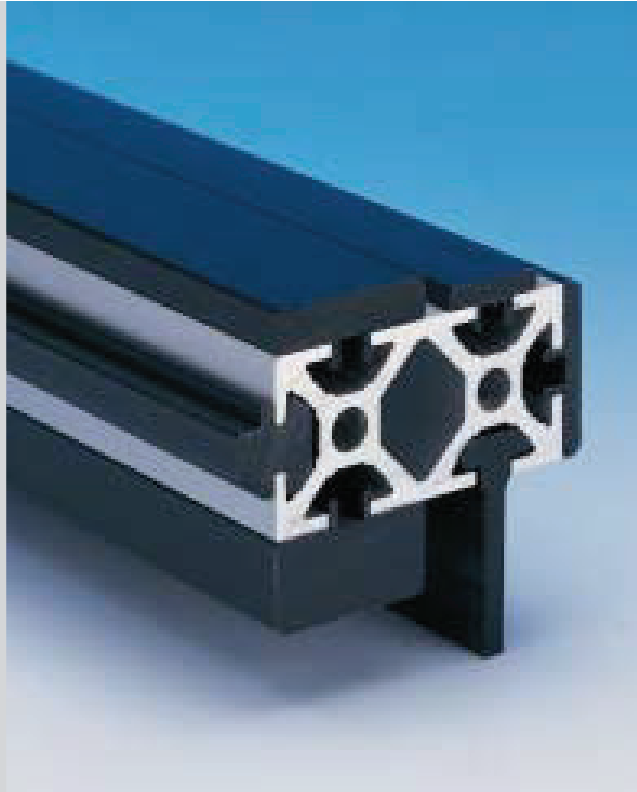

25 40 50 60

Wear Strip
mk 1025.71
25.71.2000

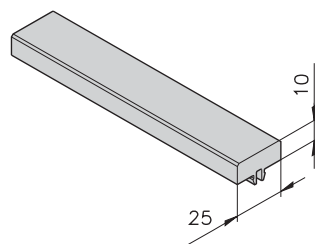

25 40 50 60

Wear Strip
mk 1025.72
25.72.2000

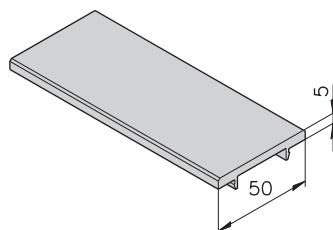

25 40 50 60

Wear Strip
mk 1025.73
25.73.2000

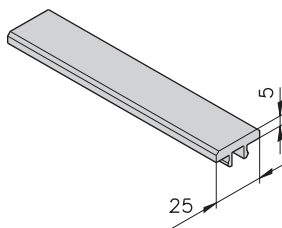

25 40 50 60

Wear Strip
mk 1000
22.00.2000

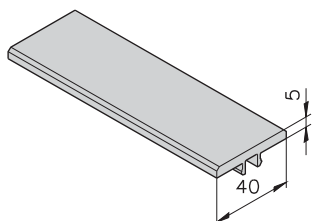

25 40 50 60

Wear Strip
mk 1040.01
21.01.2000

Wear Strips

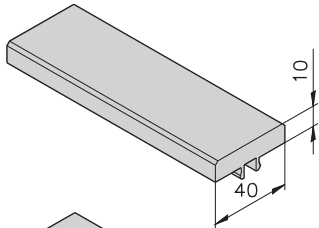

25 40 50 60

Wear Strip
 mk 1040.02
 21.02.2000

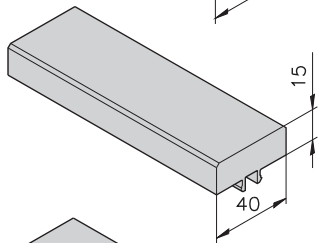

25 40 50 60

Wear Strip
 mk 1040.03
 21.03.2000

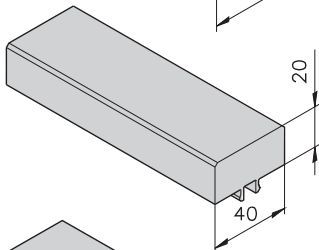

25 40 50 60

Wear Strip
 mk 1040.04
 21.04.2000

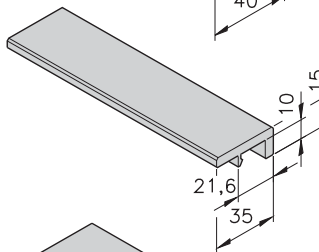

25 40 50 60

Wear Strip
 mk 1040.05
 21.05.2000

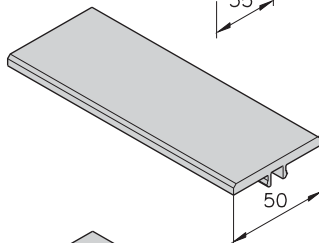

25 40 50 60

Wear Strip
 mk 1001
 22.01.2000

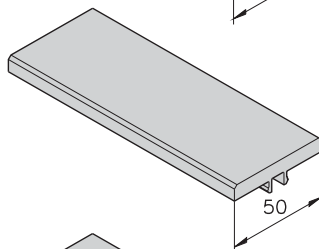

25 40 50 60

Wear Strip
 mk 1017
 22.17.2000

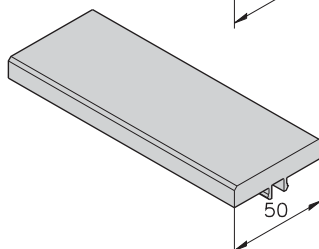

25 40 50 60

Wear Strip
 mk 1070
 22.70.2000

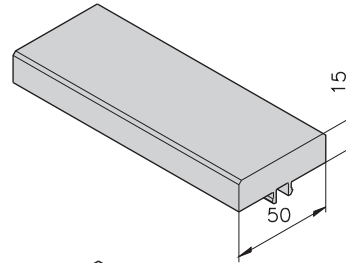

25 40 50 60

Wear Strip
 mk 1071
 22.71.2000

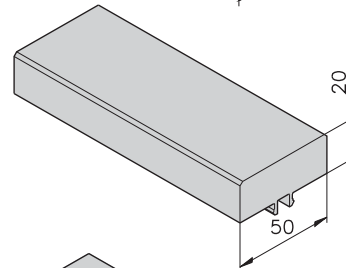

25 40 50 60

Wear Strip
 mk 1072
 22.72.2000

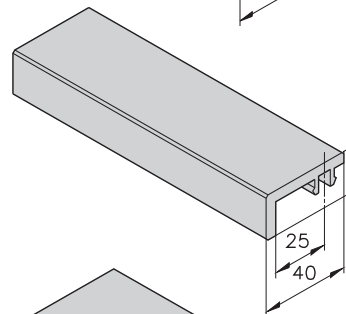

25 40 50 60

Wear Strip
 mk 1008
 22.08.2000

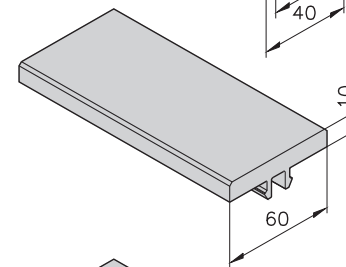

25 40 50 60

Wear Strip
 mk 1060.62
 21.62.2000

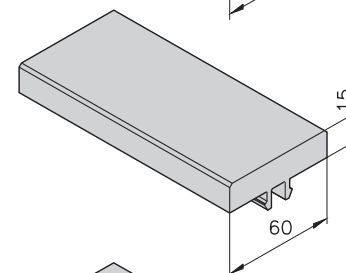

25 40 50 60

Wear Strip
 mk 1060.63
 21.63.2000

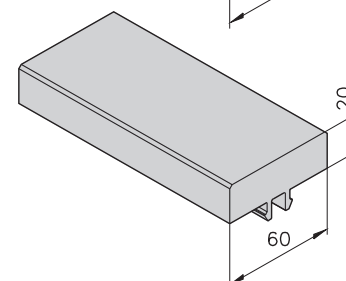

25 40 50 60

Wear Strip
 mk 1060.64
 21.64.2000

Accessory Components

Wear Strips

Wear Strips for Door Stops

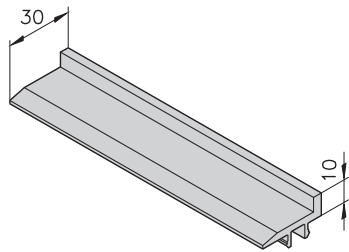
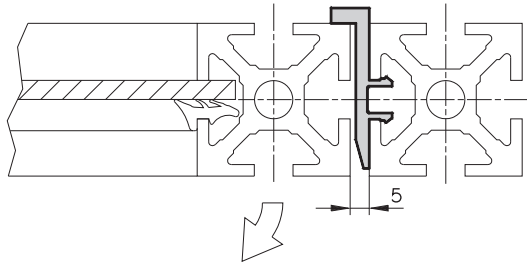

25 40 50 60

Wear Strip
mk 1091
22.91.2000

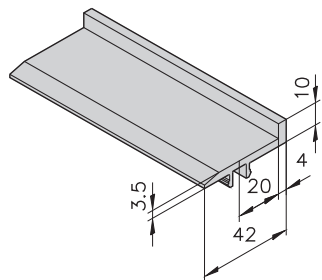

25 40 50 60

Wear Strip
mk 1090
22.90.2000

Wear Strips for Guides

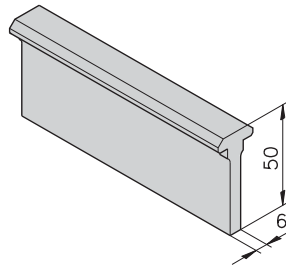
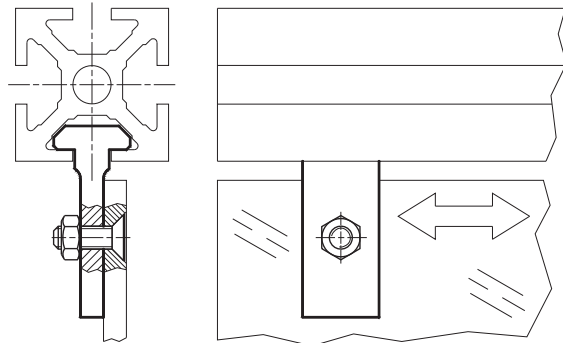

25 40 50 60

Wear Strip
mk 1009
22.09.2000

Wear Strips for Side Rails

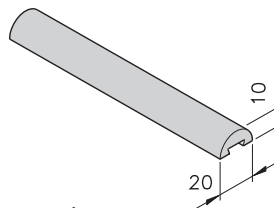
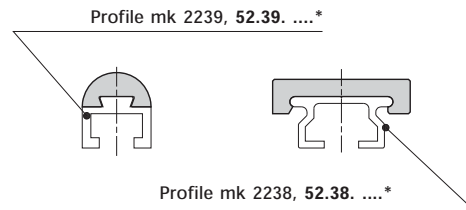

Wear Strip
mk 1030
22.30.2000

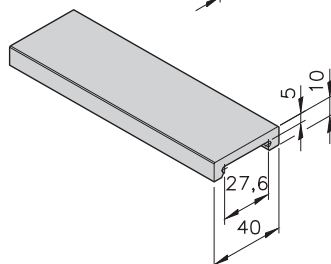

Wear Strip
mk 1031
22.31.2000

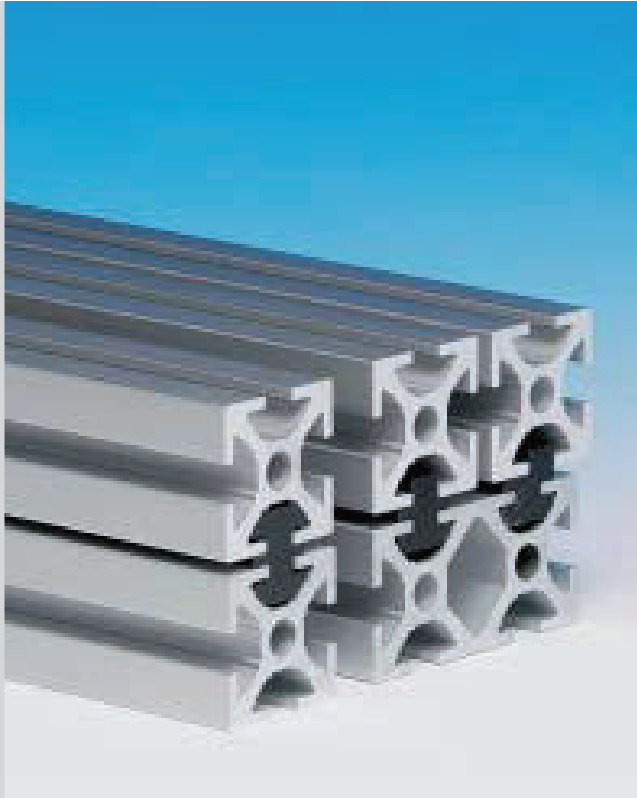

Wear Strips

Wear Strips for Guides and Slides

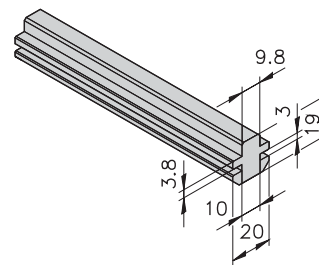

25 | 40 | 50 | 60

**Wear Strip
mk 1026
22.26.2000**

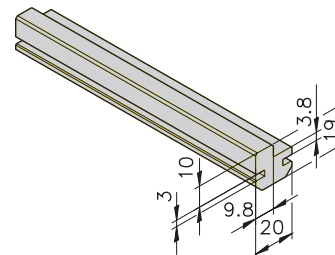

25 | 40 | 50 | 60

**Wear Strip
mk 1027
22.27.2000**

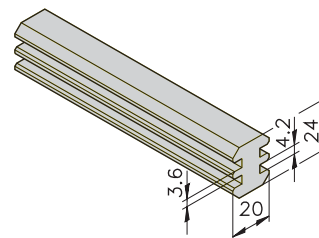

25 | 40 | 50 | 60

**Wear Strip
mk 1021
22.21.2000**

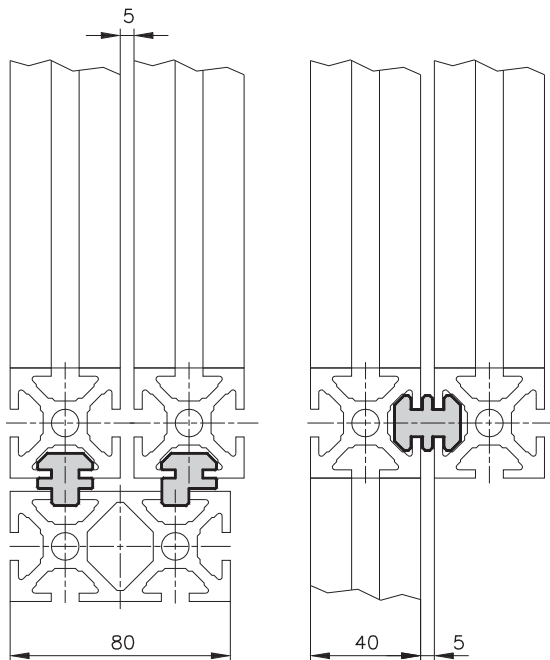

Accessory Components

Joints

Series 40

To attach profiles at various angles. The joints shown on this page are designed to be tightened at desired angles, and are not suitable for continuous actuation. Max. load 200 kg.

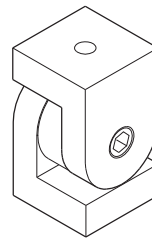
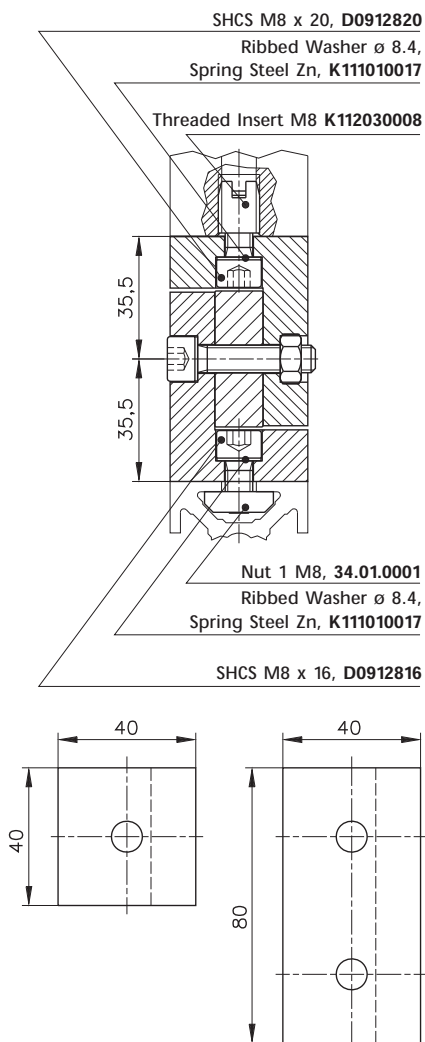

25 40 50 60

Joint B21 B46.01.221

Angle range + - 90°
complete as shown

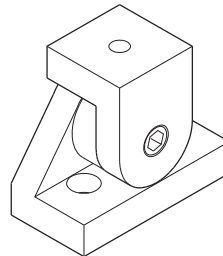

25 40 50 60

Joint B22 B46.01.222

Angle range + - 53°
complete as shown

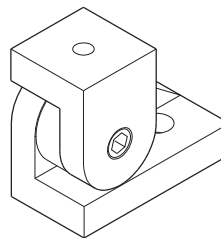

25 40 50 60

Joint B23 B46.01.223

Angle range + 90°/ - 37°
complete as shown

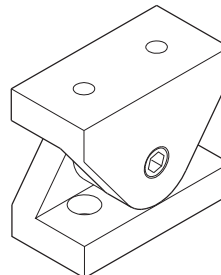

25 40 50 60

Joint B24 B46.01.224

Angle range + - 53°
complete as shown

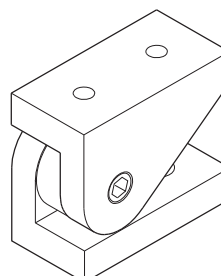

25 40 50 60

Joint B25 B46.01.225

Angle range + 90°/ - 37°
complete as shown



Joints

Series 40

When tightened, the Joints with glide bushings remain movable. Max. load 200 kg.

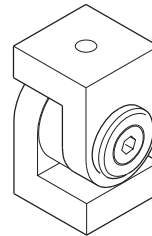
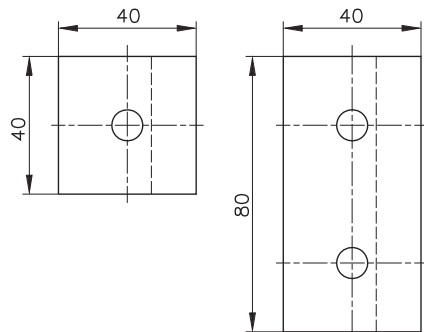
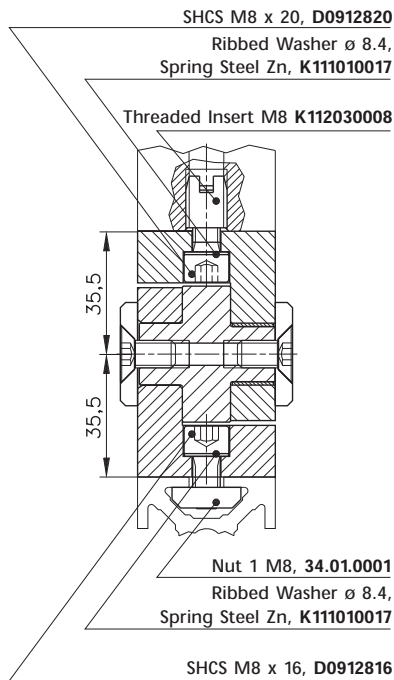

25 40 50 60

Joint B01
B46.01.201
 Angle range + - 90°
 complete as shown

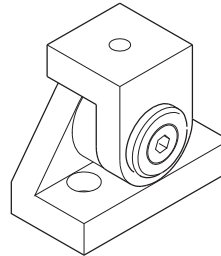

25 40 50 60

Joint B02
B46.01.202
 Angle range + - 53°
 complete as shown

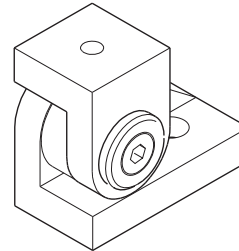

25 40 50 60

Joint B03
B46.01.203
 Angle range + 90°/ - 37°
 complete as shown

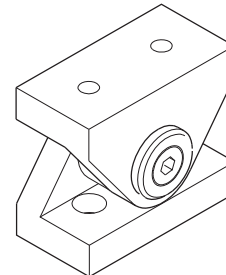

25 40 50 60

Joint B04
B46.01.204
 Angle range + - 53°
 complete as shown

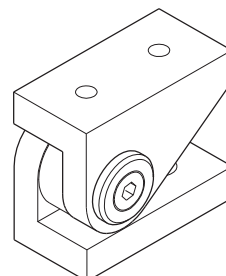

25 40 50 60

Joint B05
B46.01.205
 Angle range + 90°/ - 37°
 complete as shown

Accessory Components

Joints

Series 50

To attach profiles at various angles. The joints shown on this page are designed to be tightened at desired angles, and are not suitable for continuous actuation. Max. load 300 kg.

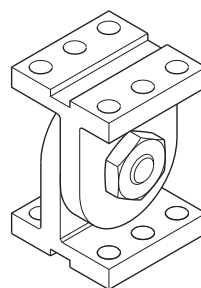
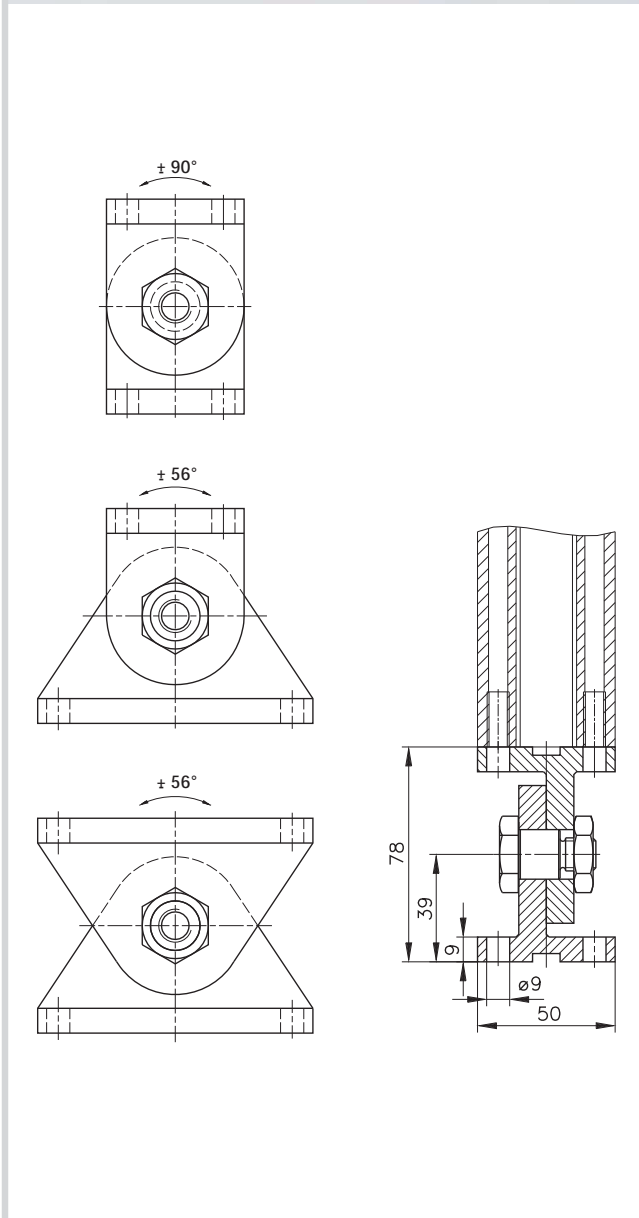

M8x20

25 40 50 60

Joint B50
B46.01.250

for 2x mk 2000 profile end
complete as shown

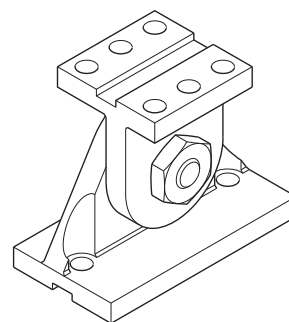

25 40 50 60

Joint B51
B46.01.251

for mk 2000 profile end
and Series 50 T-slot
complete as shown

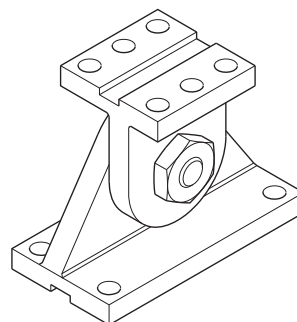

25 40 50 60

Joint B52
B46.01.252

for mk 2000 profile end
and mk 2004 profile end
complete as shown

Joints

Series 50

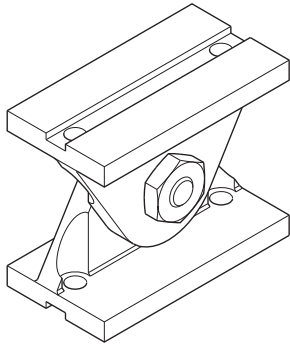

M8x20

25 | 40 | 50 | 60

Joint B53
B46.01.253
 for 2x Series 50 T-slot
 on Series 50 slot side
 complete as shown

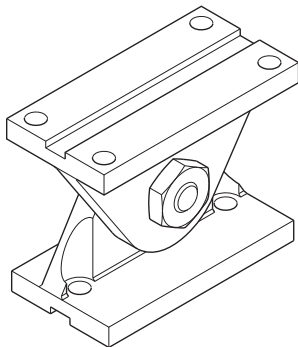

25 | 40 | 50 | 60

Joint B54
B46.01.254
 for mk 2004 profile end
 and Series 50 T-slot
 complete as shown

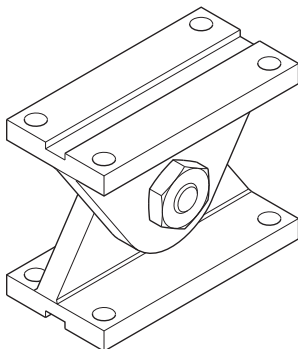

25 | 40 | 50 | 60

Joint B55
B46.01.255
 for 2x mk 2004 profile end
 complete as shown



Accessory Components

Ball Bases, Clamps and Rods

Ball Bases

The Ball Bases are made of cast iron, and have a 60° range of motion. When at the desired angle, the position is maintained by tightening the included M8 x 25 SHCS.

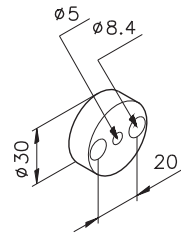

25 40 50 60

Spacer
14.04.0007
AlCuMGPb

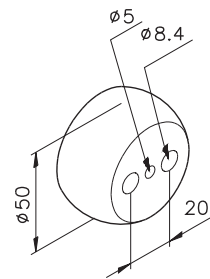

25 40 50 60

Ball
30.01.0007
Stainless Steel 1.4305

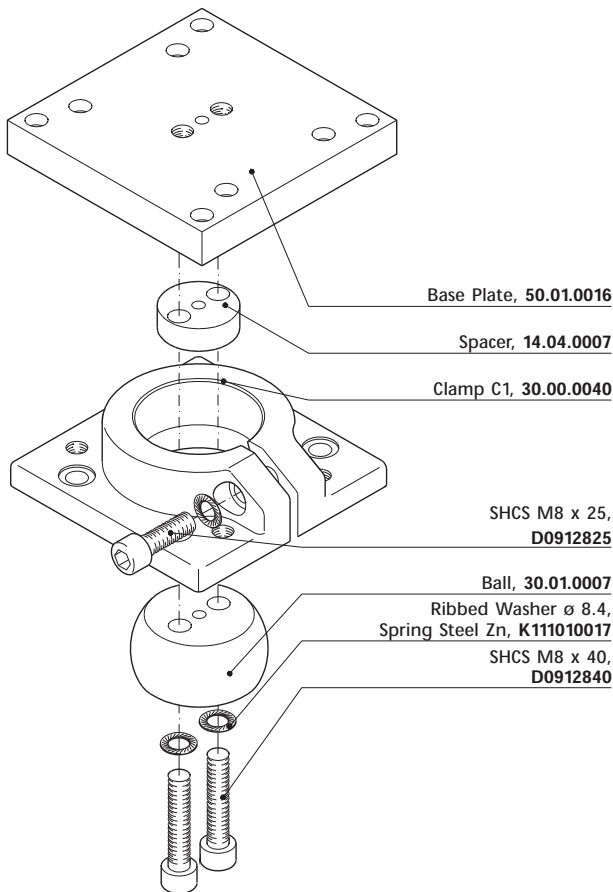

Base Plate, 50.01.0016

Spacer, 14.04.0007

Clamp C1, 30.00.0040

SHCS M8 x 25,
D0912825

Ball, 30.01.0007
Ribbed Washer ϕ 8.4,
Spring Steel Zn, K111010017

SHCS M8 x 40,
D0912840

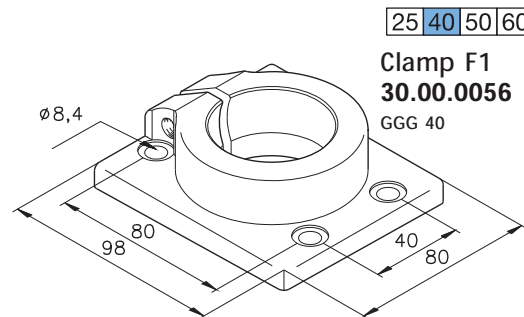

25 40 50 60

Clamp F1
30.00.0056
GGG 40

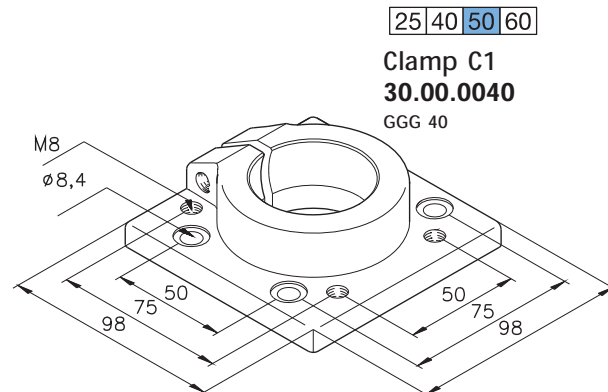

25 40 50 60

Clamp C1
30.00.0040
GGG 40

Ball Bases, Clamps and Rods

Ball Bases

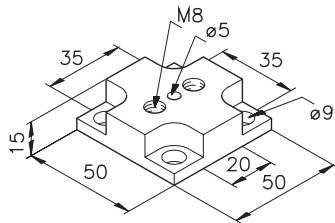

25 | 40 | 50 | 60

Base Plate
50.01.0014
 Al tumbled

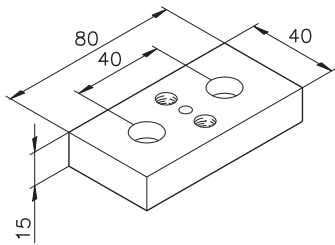

25 | 40 | 50 | 60

Base Plate
50.01.0020
 Al tumbled

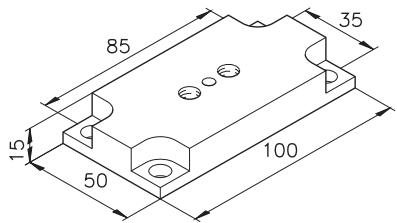

25 | 40 | 50 | 60

Base Plate
50.01.0015
 Al tumbled

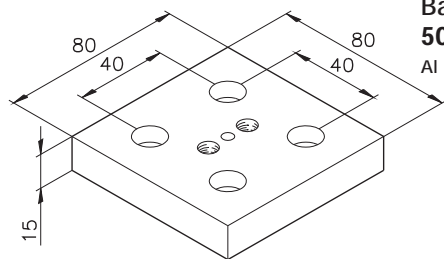

25 | 40 | 50 | 60

Base Plate
50.01.0021
 Al tumbled

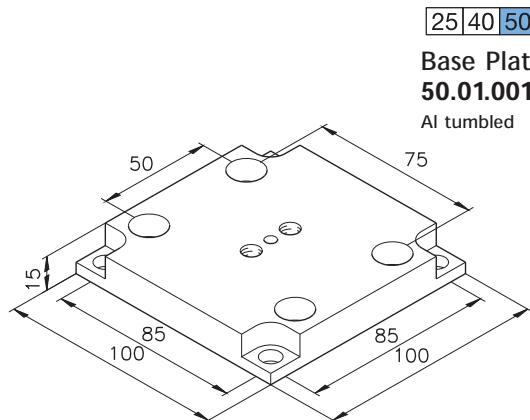

25 | 40 | 50 | 60

Base Plate
50.01.0016
 Al tumbled

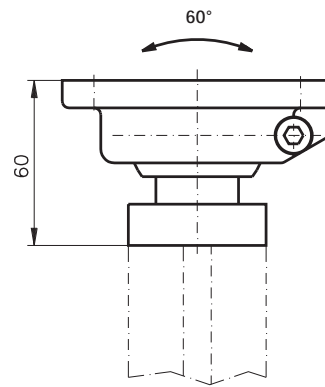

25 | 40 | 50 | 60

Ball Base C1
B46.02.010
 for mk 2000

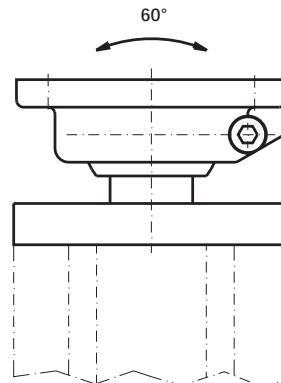

25 | 40 | 50 | 60

Ball Base C2
B46.02.011
 for mk 2004

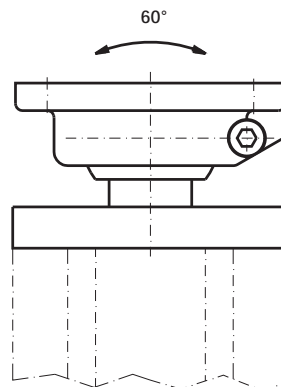

25 | 40 | 50 | 60

Ball Base C3
B46.02.012
 for mk 2005 and mk 2011



Accessory Components

Ball Bases, Clamps and Rods

Swivel Clamps



mk Swivel Clamps are used heavily in the area of material handling side guides/rails. They allow guide rods to be positioned at various angles and heights.

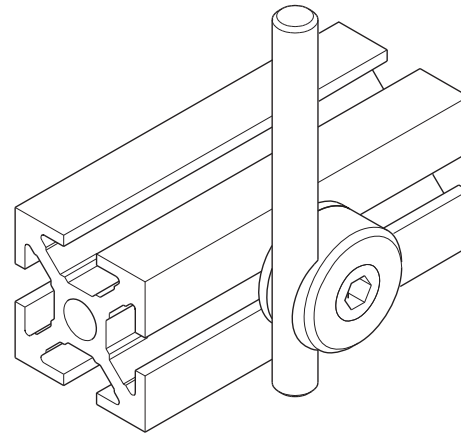
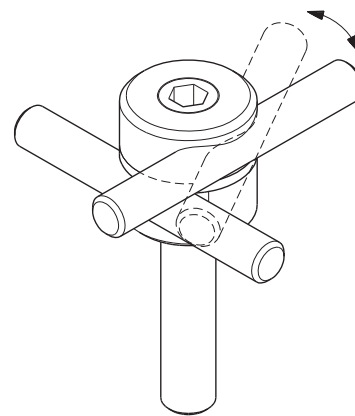

Clamp Stainless Steel, 30.00.0023
Clamp Plastic, mk 2522

SHCS M8 x 20,
D0912820

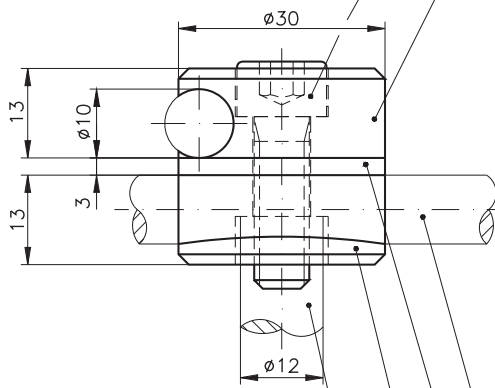

Rod M8 \varnothing 12, SS, 7000AA*

Clamp Stainless Steel, 30.00.0023
Clamp Plastic, mk 2522

Washer, SS, 63.00.0016

Rod \varnothing 10, SS, 7000AB*

Ball Bases, Clamps and Rods

Swivel Clamps

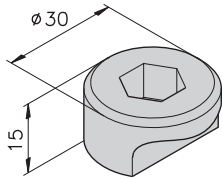

25 40 50 60

**Clamp
mk 2522**
 PA6GF 30%,
 Fiber-reinforced

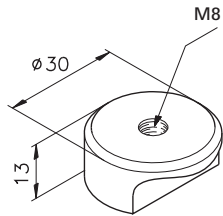

25 40 50 60

**Clamp
30.00.0024**
 Stainless Steel 1.4305

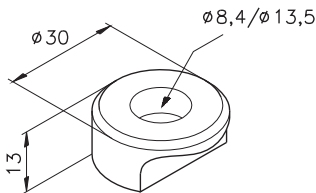

25 40 50 60

**Clamp
30.00.0023**
 Stainless Steel 1.4305

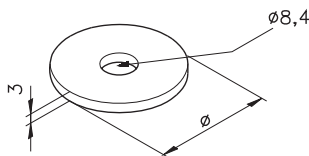

25 40 50 60

**Washer \varnothing 30
63.00.0016**
 Stainless Steel 1.4305

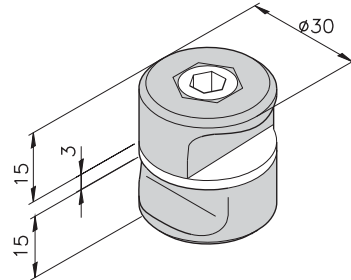

25 40 50 60

**Clamp complete
B46.02.005**
 PA6GF 30%,
 Fiber-reinforced

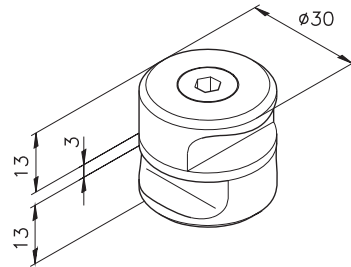

25 40 50 60

**Clamp complete
B46.02.004**
 Stainless Steel 1.4305

Accessory Components

Ball Bases, Clamps and Rods

Clamps and Offsets

Clamps for rod mounting

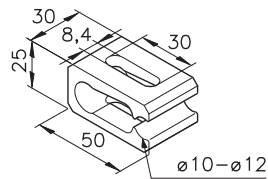

Clamp
30.00.0002
Al tumbled

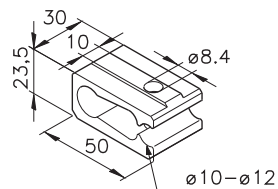

Clamp
30.00.0001
Al tumbled
for 10mm T-slot

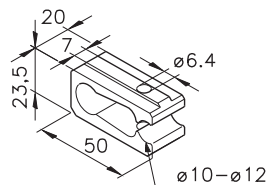

Clamp
30.00.0017
Al tumbled
for 7mm T-slot

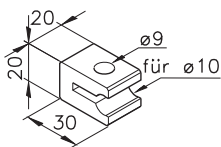

Clamp short
30.00.0038
Al tumbled

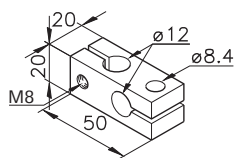

Clamp
right
30.00.0013
Al tumbled

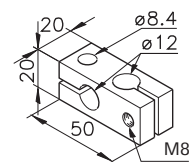

Clamp
left
30.00.0047
Al tumbled

Offsets for width adjustment

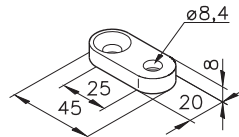

Offset 25
34.09.0003
Al tumbled

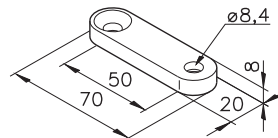

Offset 50
34.09.0004
Al tumbled

Ball Bases, Clamps and Rods

Rods

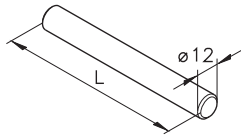

25 40 50 60

**Rod \varnothing 12
7000AD.***
 Stainless Steel 1.4305,
 Stock length 50, 75, 100, 150,
 200 and 250 mm

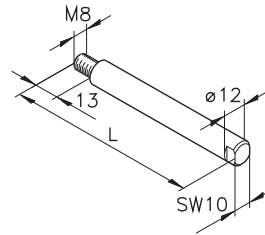

25 40 50 60

**Guide Rod \varnothing 12
7000CA.***
 Stainless Steel 1.4305,
 Stock length 50, 75
 and 100 mm

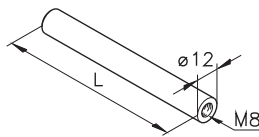

25 40 50 60

**Rod \varnothing 12
7000AA....***
 Stainless Steel 1.4305,
 M8x16 thread, one end
 Stock length 50, 75, 100, 150
 and 200 mm

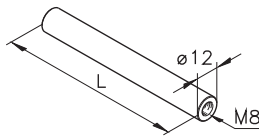

25 40 50 60

**Guide Rod \varnothing 12
7000AF.***
 Stainless Steel 1.4305,
 M8x16 thread, both ends
 Stock length 50, 75, 100
 and 150 mm

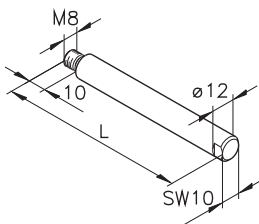

25 40 50 60

**Guide Rod \varnothing 12
7000CC.***
 Stainless Steel 1.4305,
 Stock length 50, 75
 and 100 mm

Accessory Components

Accessory Components for Guardrails



These accessory components for rails are typically used in combination with profiles mk 2040.01 and mk 2040.16. They are aluminum, and feature a tumbled finish. Please note that they are not designed for exterior use.

[see Factory Equipment catalog](#)

Joint 40/H5 B46.01.026

Threaded Insert M8, 9520K, K112030008

SHCS, M8 x 60, D0912860

SHCS, M8 x 20, D0912820

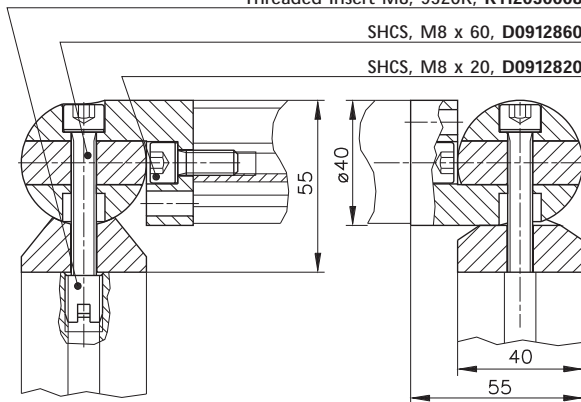

T-Connector 79.00.0011

SHCS, M8 x 16, D0912816

Nut 1 M8, 34.01.0001

SHCS, M8 x 20, D0912820

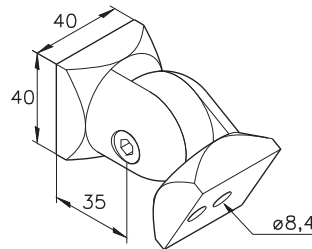
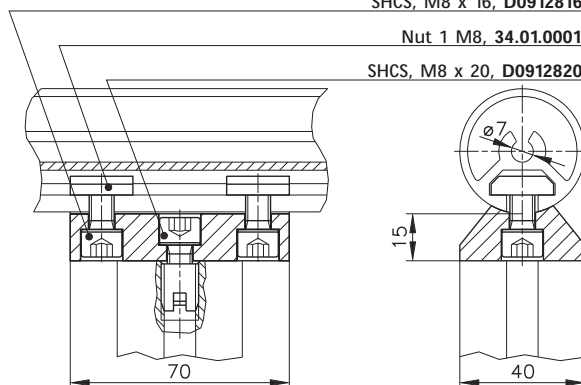

**Joint 40/H1
B46.01.022**
with mounting hardware

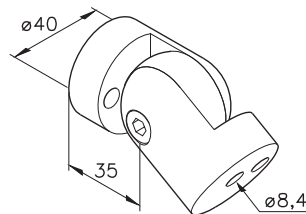

**Joint 40/H2
B46.01.023**
with mounting hardware

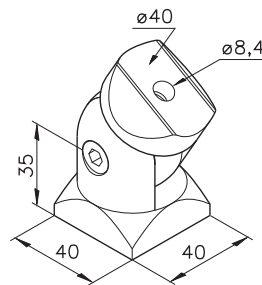

**Joint 40/H4
B46.01.025**
with mounting hardware

Accessory Components for Guardrails

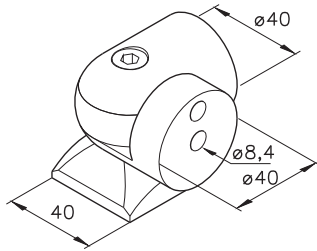

Joint 40/H5
B46.01.026
 with mounting hardware

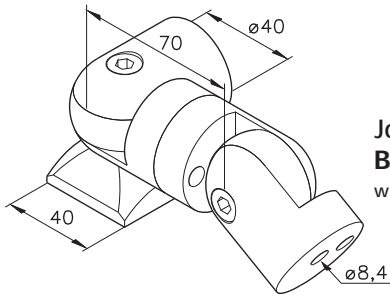

Joint 40/H3
B46.01.024
 with mounting hardware

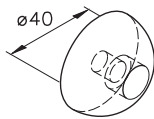

End Cap
 for Profile
 mk 2040.16
76.01.0002
 Al, tumbled

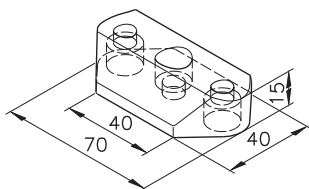

T-Connector
 for Profile
 mk 2040.16
79.00.0011
 Al, tumbled

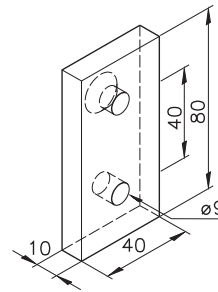

Wall attachment
 for Profile
 mk 2040.01
50.03.0033
 Al, tumbled

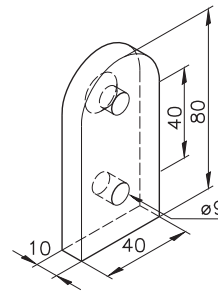

Wall attachment
 for Profil
 mk 2040.16
50.03.0034
 Al, tumbled

Accessory Components

Glides and Bushings

The following components are often used in material handling applications as stops or singulators, for example. Using just a few elements, guides for a variety of tooling can be made as well. These components are designed for use with profile mk 2000.

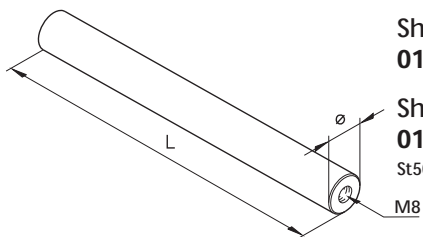

Shaft \varnothing 12
0100AF*

Shaft \varnothing 16
0100AA*
St50K h6

Shaft \varnothing 12
0100AE*

Shaft \varnothing 16
0100AB*

hardened h6
Stock length 150, 200, 250,
300, 350 and 400 mm

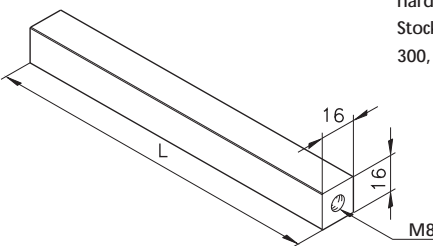

Shaft
0101AA*

Steel C45 polished h9
Stock length 150, 200, 250,
300, 350 and 400 mm

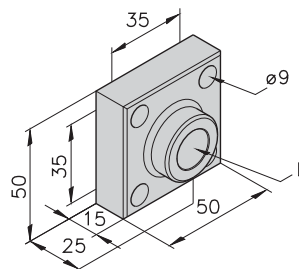

Bushing \varnothing 12
35.00.0007
D = 12 mm

Bushing \varnothing 16
35.00.0006
D = 16 mm,
Delrin

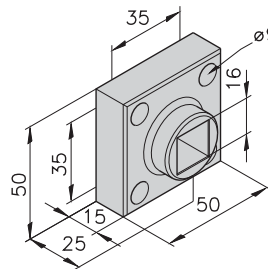

Bushing \square 16
35.00.0008
Delrin

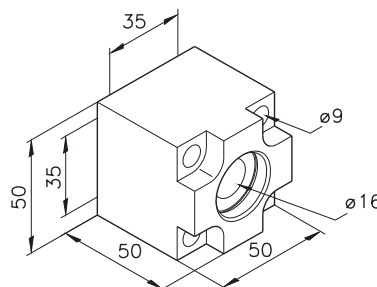

Bushing with
Linear Bearing
B40.03.002
Aluminum with linear
bearing 16/26 x 36 mm

Glides and Bushings



A handful of components are all that is required to manufacture Pneumatic Glide System 2000. Various manufacturers pneumatic cylinders, conforming to ISO 6432 or Cetop RP52P with 20 or 25 mm bores and strokes to 300 mm can be used. Customer standards can be accommodated as the system is based on the air cylinder. Mechanically the assemblies are the same. Please note that cylinders must be ordered separately.

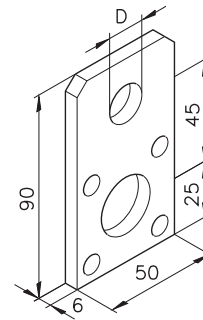
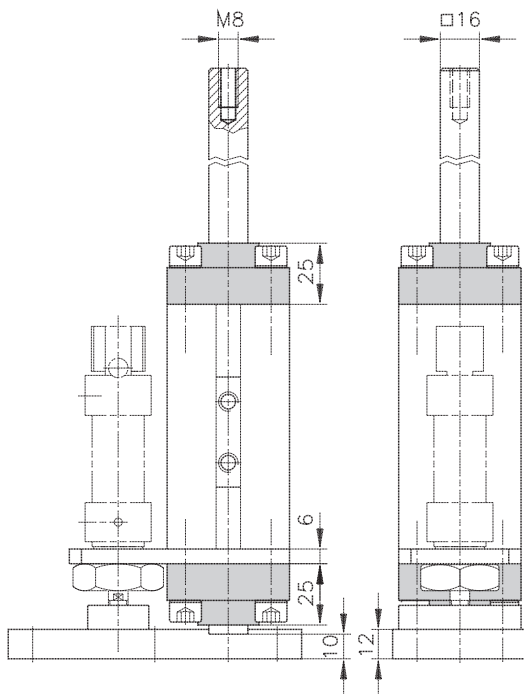

Cylinder Plate
50.05.0036

Al, tumbled, D = 22.5 mm
 Bore \varnothing 20 and \varnothing 25

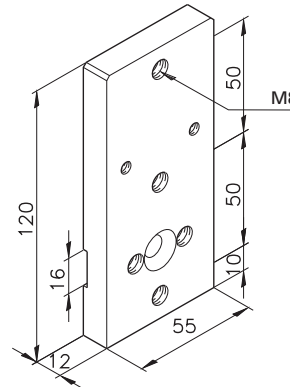

Cylinder Plate
50.09.0017

Al, tumbled

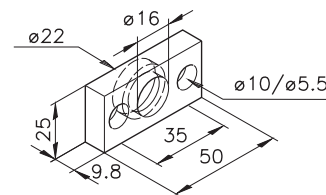

Cylinder Plate
50.09.0018

Al, tumbled

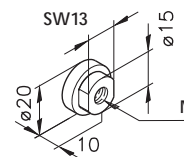

Step Washer M8
63.03.0001

Steel, Cylinder \varnothing 20

Step Washer
M10 x 125
63.03.0003

Steel, Cylinder \varnothing 25

Accessory Components

Bumpers

Elastomere Shore 55

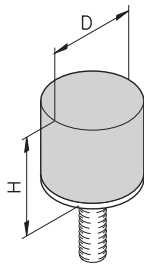

Bumper Type D

| D | H | Thread | Ident-No. |
|----|----|----------|------------|
| 20 | 12 | M6 x 12 | K113060004 |
| 20 | 12 | M6 x 15 | K113060001 |
| 30 | 28 | M8 x 20 | K113060002 |
| 50 | 21 | M10 x 28 | K113060003 |

Bumper Type D

Nut M6, D09346

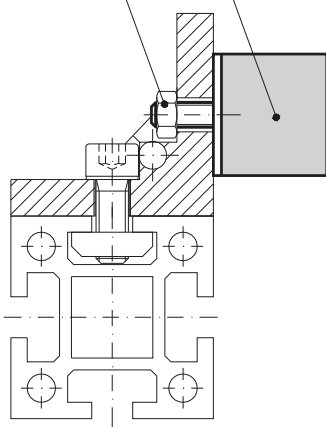

Bumper Type KP/D

Nut 1 M8, 34.01.0001

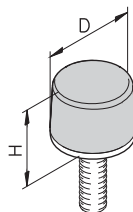
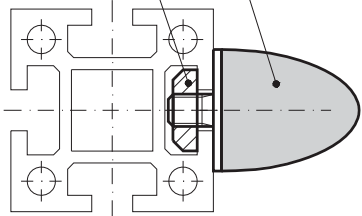

Bumper Type K/D

| D | H | Thread | Ident-No. |
|----|----|----------|------------|
| 25 | 17 | M6 x 18 | K113060006 |
| 50 | 18 | M10 x 28 | K113060007 |

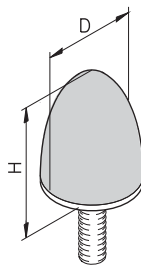

Bumper Type KP/D

| D | H | Thread | Ident-No. |
|----|----|---------|------------|
| 30 | 36 | M8 x 10 | K113060012 |
| 30 | 36 | M8 x 20 | K113060011 |

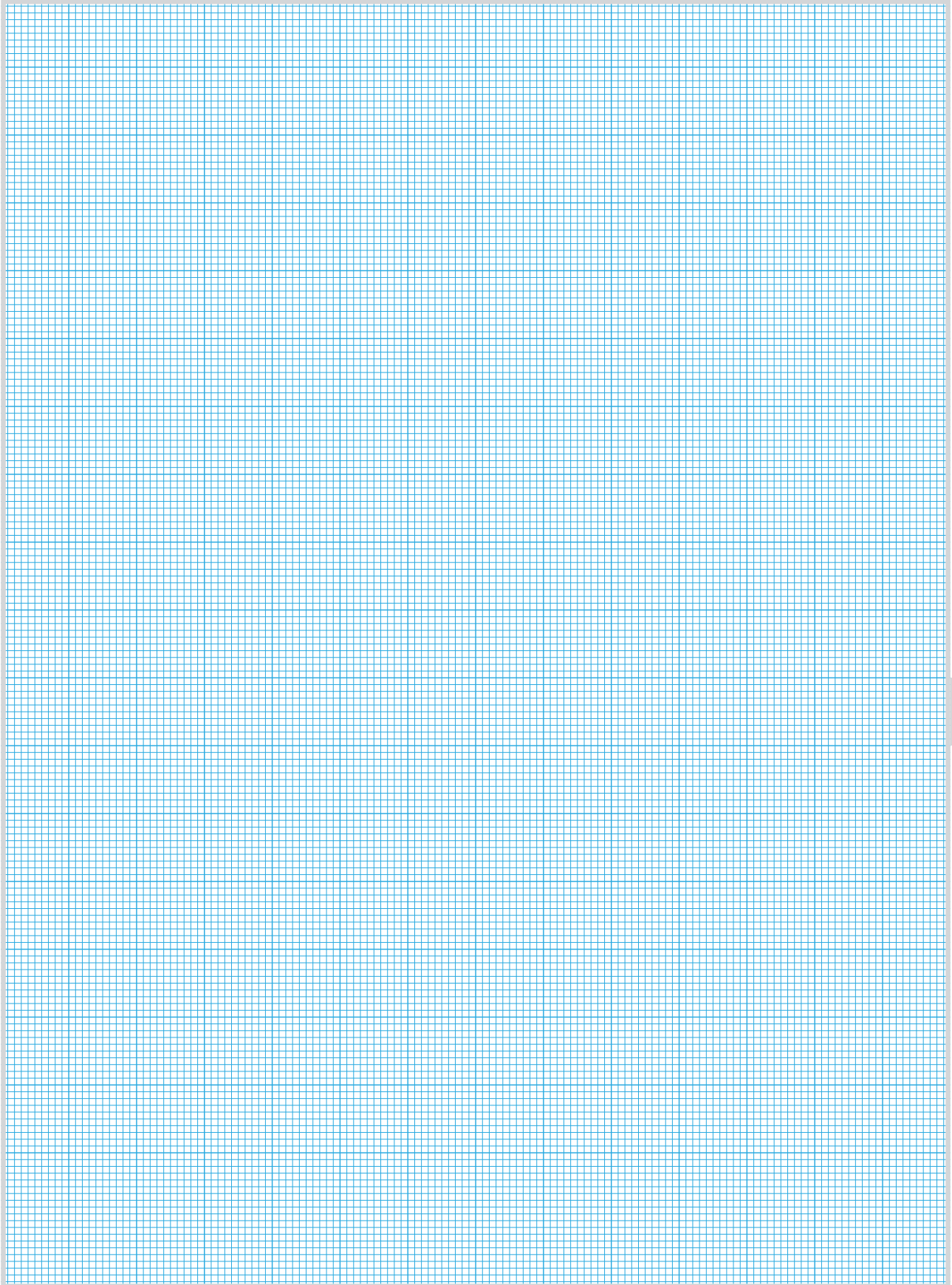

Accessory Components

Tools

Drill



| ø | Type | Order Number |
|-----|-------------|--------------|
| 5.8 | Twist-Drill | K903000058 |
| 7 | Twist-Drill | K903000070 |
| 8 | Twist-Drill | K903000080 |
| 9 | Twist-Drill | K903000090 |
| 10 | Twist-Drill | K903000100 |

Taps and Threadformers



| Thread | Type | Order Number | Thread | Type | Order Number |
|-----------|--------------|--------------|--------|------------------|--------------|
| M5 | Tap | K903060005 | M4 | Tap for Helicoil | K903060204 |
| M5 x 0.5 | Tap | K903060105 | M6 | Tap for Helicoil | K903060206 |
| M8 | Threadformer | K903070008 | M8 | Tap for Helicoil | K903060208 |
| M8 | Tap | K903060008 | M10 | Tap for Helicoil | K903060210 |
| M8 x 1 | Tap | K903060108 | | | |
| M9 x 1 | Tap | K903060109 | | | |
| M10 | Tap | K903060010 | | | |
| M12 | Tap | K903060012 | | | |
| M12 x 1.5 | Tap | K903060113 | | | |
| M16 | Tap | K903060016 | | | |
| M16 x 1.5 | Tap | K903060116 | | | |

Tools for threaded inserts



| Thread | Tool Length | Type | Order Number | Thread | Tool Length | Type | Order Number |
|--------|-------------|------|--------------|--------|-------------|------|--------------|
| M3 | 58 | H | K902010004 | M6 | 102 | M | K902010011 |
| M3 | 82 | M | K902010005 | M8 | 81 | H | K902010012 |
| M5 | 69 | H | K902010008 | M8 | 105 | M | K902010013 |
| M5 | 101 | M | K902010009 | M12 | 95 | H | K902010016 |
| M6 | 74 | H | K902010010 | M12 | 118 | M | K902010017 |

Type H=Hand operated, Type M=Machine operated

Insert Tools for Helicoil inserts



| Thread | Type | Order Number | Thread | Type | Order Number |
|--------|------|--------------|--------|------|--------------|
| M4 | H | K902010204 | M8 | H | K902010208 |
| M6 | H | K902010206 | M10 | H | K902010210 |

Type H=Hand operated

Tools

Wrench Set



The ball-end allows quick and easy installation of the screw. When tightening, the longer arm of the wrench provides a sufficient torque arm to set the fastener. The wrenches are made of Chrome-Vanadium Steel.

| Type | Order Number |
|--------------------|--------------|
| Wrench Set 8-piece | K902005050 |

Magnetic Holder for Nuts



Used to grab or hold nuts in profile T-slots. Ideal for moving nuts into vertical positions. Features a chrome-plated flexible brass tube and plastic handle.

| Type | Order Number |
|-----------------|--------------|
| Magnetic Holder | K901130001 |

Parting Tool for Cleanroom Profiles



To open T-slots on Cleanroom profiles.

| Type | Order Number |
|--------------|--------------|
| Parting Tool | B46.03.102 |



Deburring Block for Cleanroom Profiles



For deburring the cut out slots in Cleanroom profiles.

| Type | Order Number |
|-----------------|--------------|
| Deburring Block | K902030001 |



Accessory Components

Tools

Drill Fixtures

The drill fixtures made of hardened steel are used to make holes for tension plugs in the profiles.

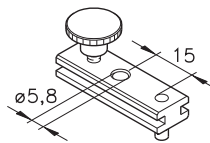
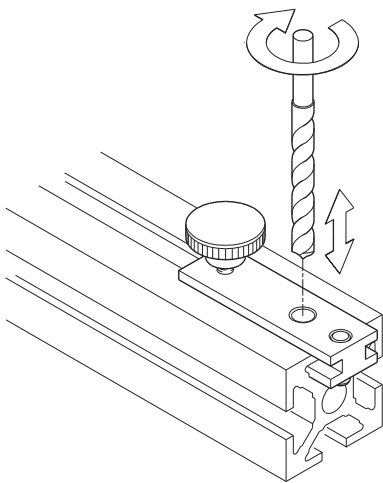
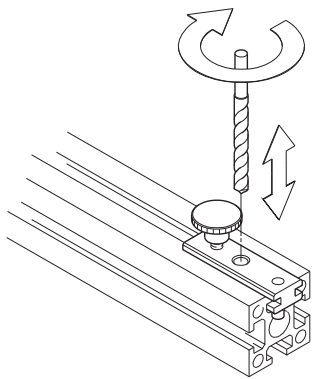

Drill Fixture
Series 25
B46.03.003

D = 5,8 mm
A = 15 mm

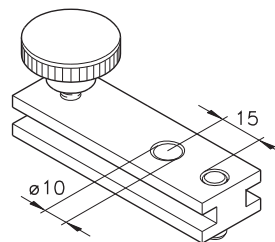

Drill Fixture
Series 40 and 50
B51.03.005

D = 10 mm
A = 15 mm

Tools

Drill Fixtures for Pneumatic Components

The drill fixture with hardened steel bushing is used to make the predrilled holes for pneumatic connections in the profiles.

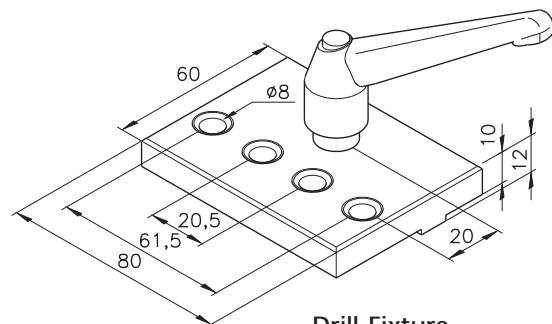
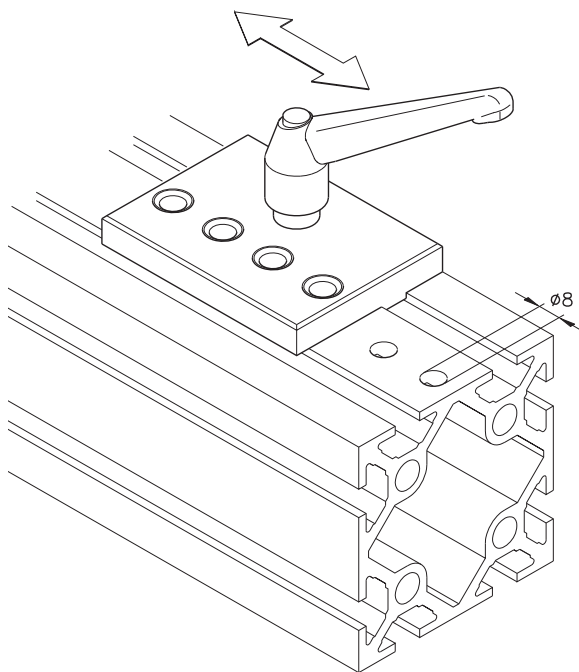

Drill Fixture
for Pneumatic
Components
B46.03.007

Accessory Components

Tools

Drill Fixtures for Cleanroom Profiles



The drill fixture with hardened steel bushing is used to make holes in cleanroom profiles.

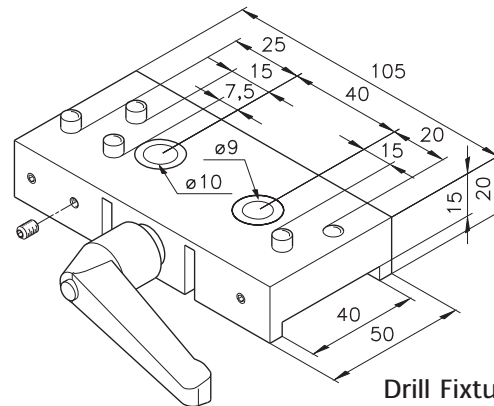
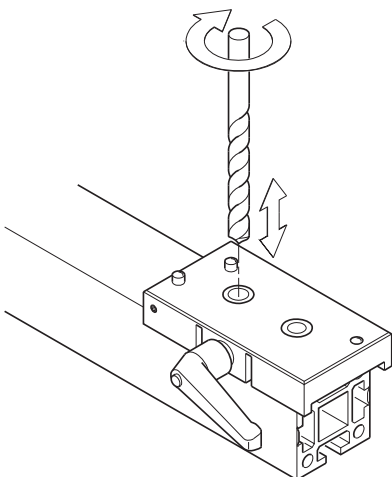
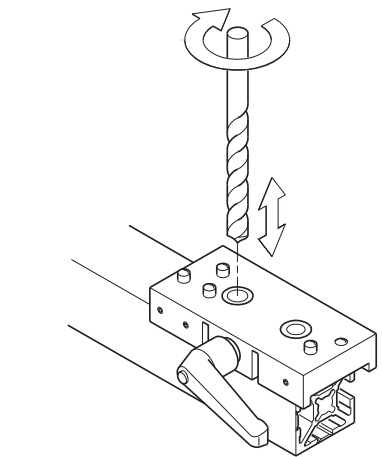

Drill Fixture
Cleanroom 40
B51.03.020

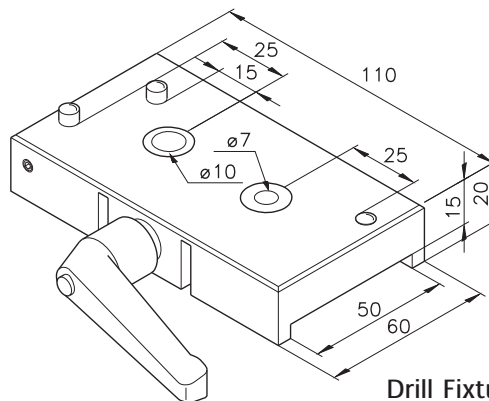

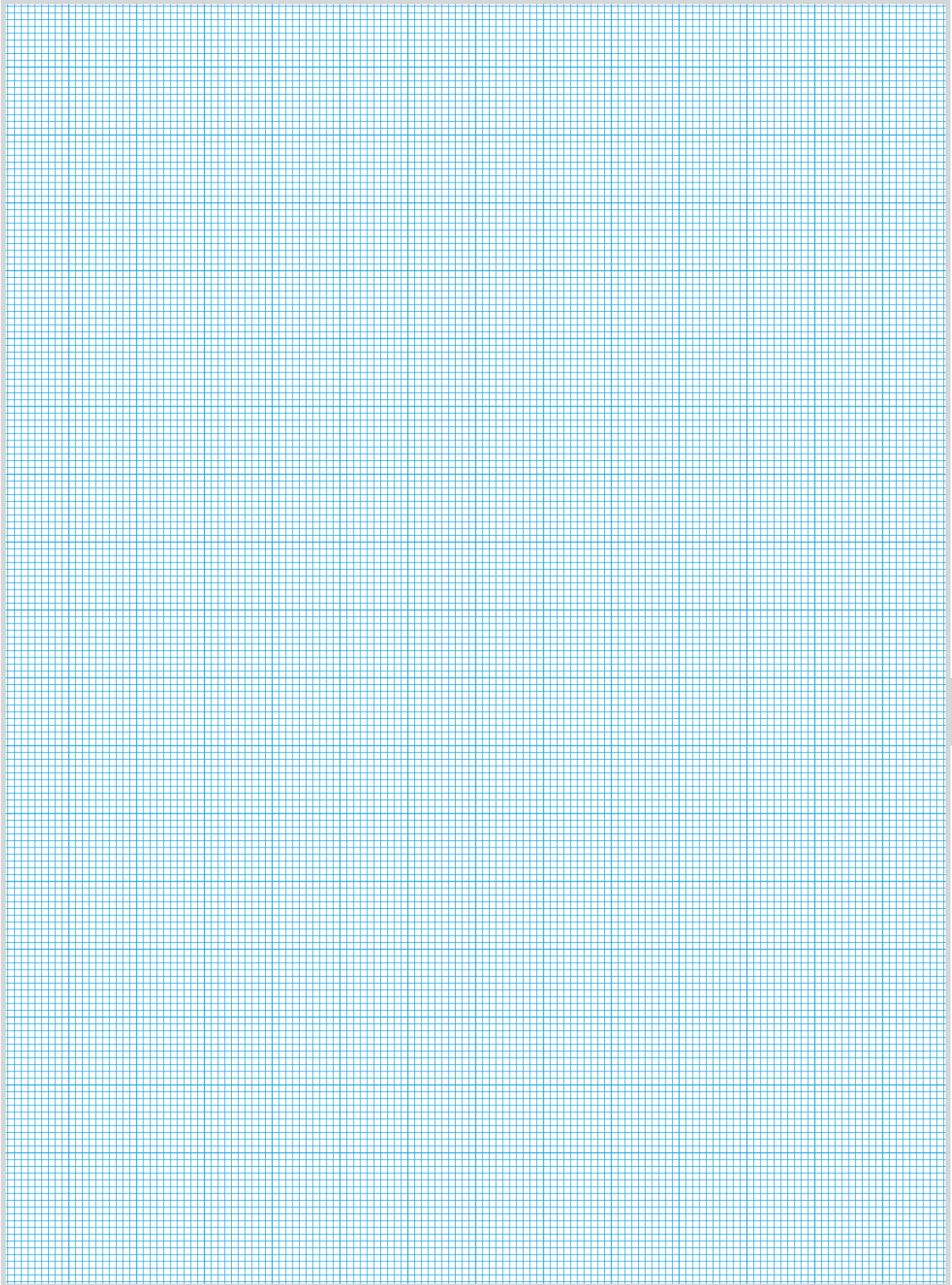

Drill Fixture
Cleanroom 50
B51.03.035



mk Assemblies



Contents mk Assemblies

| | | |
|---|-------------------|-----|
|  | Turntables | 232 |
|  | Carriage Wagons | 234 |
|  | Parallel Actuator | 236 |

Assemblies

Turntables



mk Turntables are most often used in the area of manual material handling. Heavier loads can be positioned effortlessly for assembly or machining operations.

The turntable consists of a solid cast aluminum base with an aluminum surface plate. The surface plate is supported on 6 roller bearings and rotates centric to the base on another roller bearing.

mk Turntables are available with either a $\varnothing 400$ mm round or 400 x 400 mm square surface plate. In addition, the Indexing and Fixed versions are available with 2, 4 or 6 stop locations. Special versions please inquire.

The maximum load rating is 100 kg.

Do not drill/tap in this area!

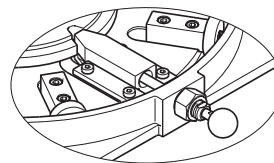
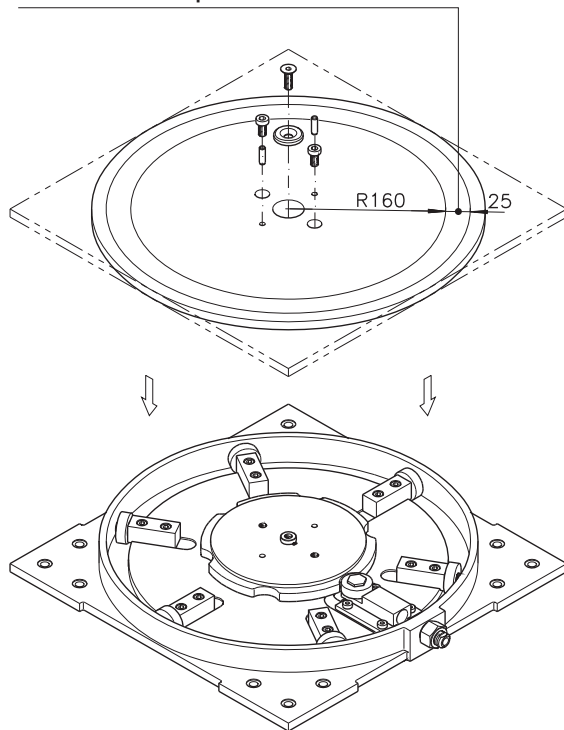

Fixed Version

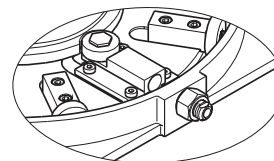
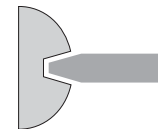

Indexing Version

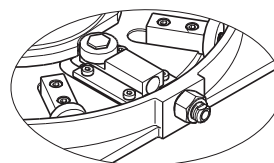
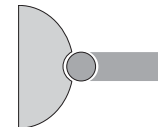

Example of a Special Version

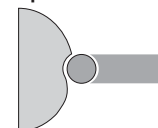

Turntables

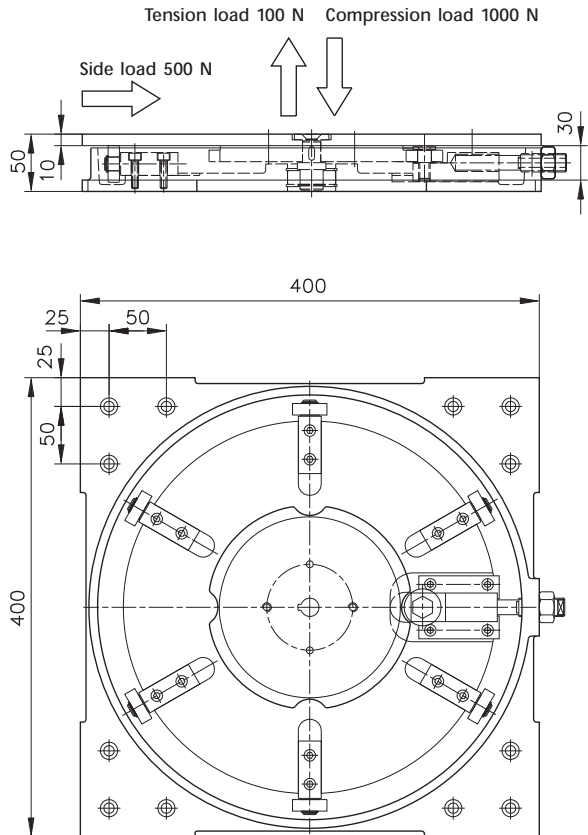

Turntable with Index
B12.00.001

not shown
 Turntable without Index
B12.00.003

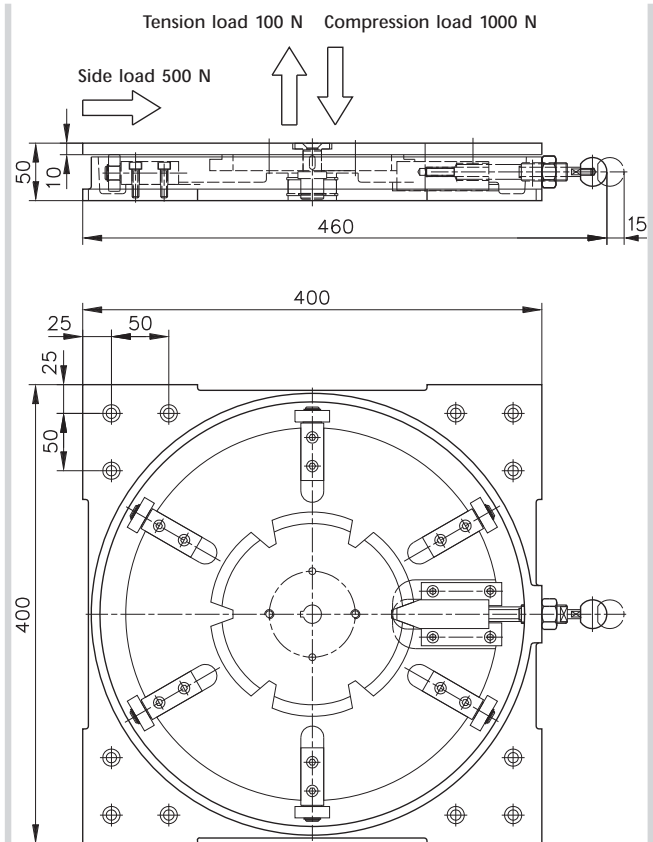

Turntable with Fixed Stops
B12.00.002

Ordering example for above drawing:
 Please indicate surface plate type (round or square) and number of Indexing, i.e. Fixed stops.

| | |
|---------------|------------|
| Turntable | B12.00.002 |
| Fixed Stops | 6 |
| Surface Plate | round |

Assemblies

Carriage Wagons

mk Carriage Wagons are used where equipment or machines are moved into position on tracks. The mk Carriage Wagons are available in stock lengths of 400, 500 and 600mm. Other versions please inquire. Please indicate roller version and wagon length when ordering.

 More roller information see page 193

| | Version | Radial load/Roller |
|----------------------|---------|--------------------|
| Flange Roller, Steel | 1 | 1000N |
| Guide Roller, POM | 2 | 200N |
| Flat Roller, POM | 4 | 200N |

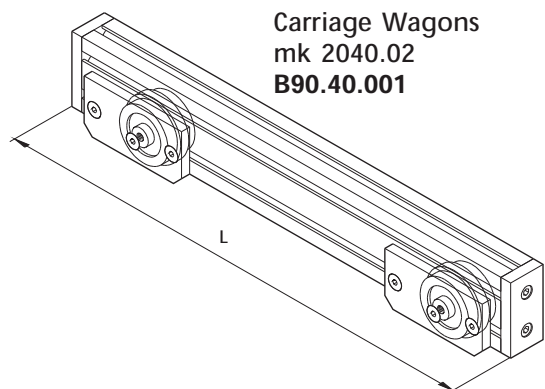
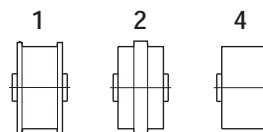

Carriage Wagons
mk 2040.02
B90.40.001

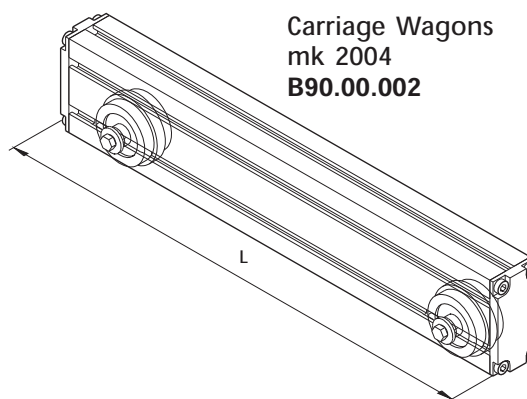
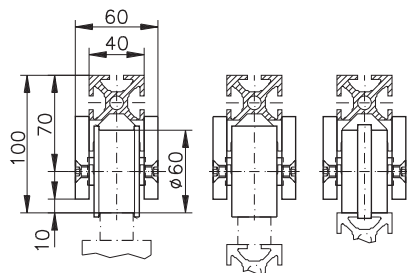

Carriage Wagons
mk 2004
B90.00.002

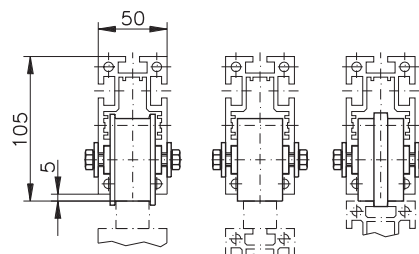

Carriage Wagons

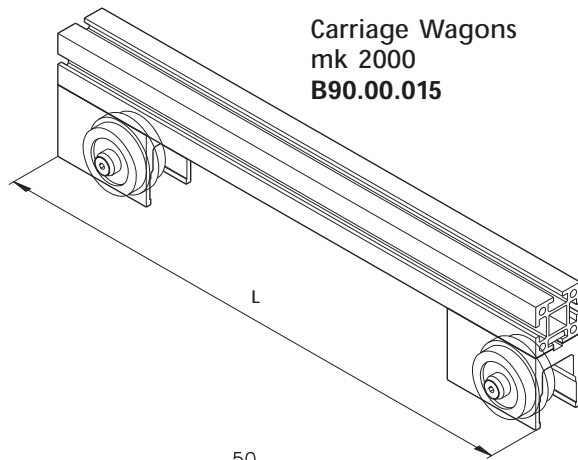

Carriage Wagons
mk 2000
B90.00.015

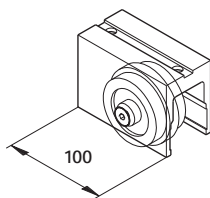
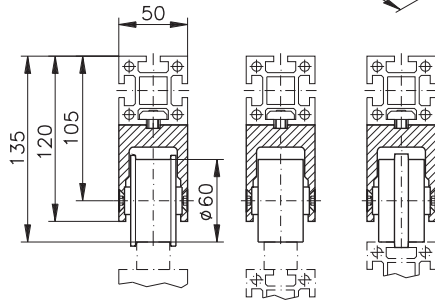

Roller Unit
B60.04.004

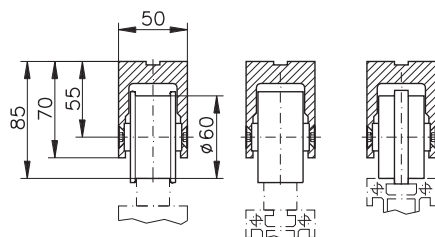

Assemblies

Parallel Actuator

Parallel Actuator Module PHM-A 20

The parallel actuator module PHM-A 20 features an external, dual-action cylinder. The parallel actuator is installed horizontally thus minimizing the required assembly space. Designed for use with an operating air pressure of 90 psi, mechanical linkages translate the horizontal cylinder force into vertical stroke and lifts between 20 and 100 kg centrally placed loads. The cylinder stroke is cushioned and helps ensure smooth operation of the actuator. End plates guide the vertical travel, and the T-slots of the structural aluminum profiles eliminate the need for special mounting plates.

The use of mk structural profiles allows for lengths from 400 mm to 1500 mm (in 100 mm increments), with longer lengths of up to 5 m available on request. The travel time is 1.5 seconds with a lifting height of 20 mm, cycle time is 4 seconds.

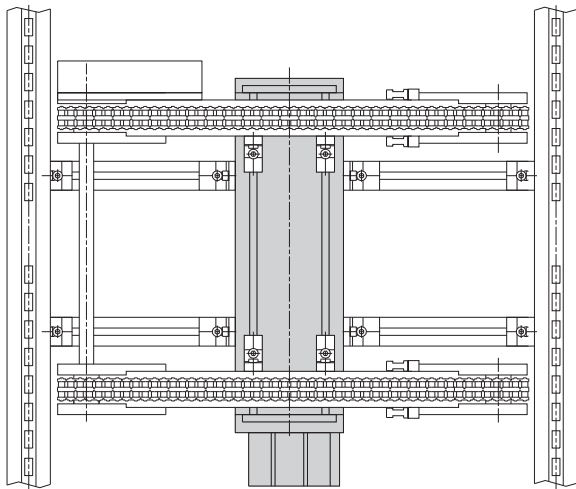
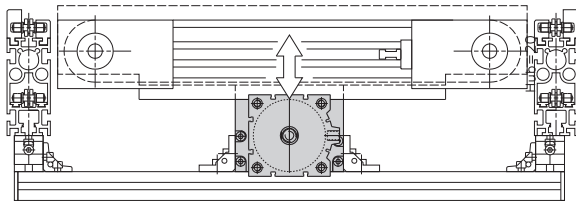

Application Used as lifting module for transfer conveyor.

External (short stroke cylinder):

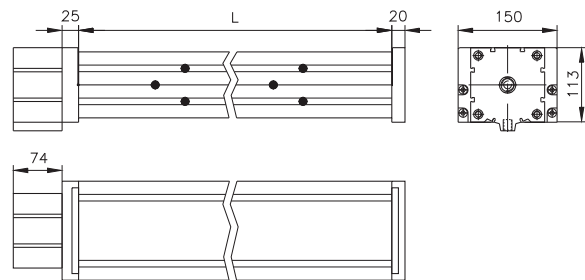

Ident Nr: **B28.00.002**

Please specify length when ordering.

Parallel Actuator

Parallel Actuator Module PHM-I 20



The parallel actuator module PHM-I 20 features an internal, dual-action cylinder. The parallel actuator is installed horizontally thus minimizing the required assembly space. Designed for use with an operating air pressure of 90 psi, mechanical linkages translate the horizontal cylinder force into vertical stroke and lifts up to 20 kg centrally placed loads. The cylinder stroke is cushioned and helps ensure smooth operation of the actuator. End plates guide the vertical travel, and the T-slots of the structural aluminum profiles eliminate the need for special mounting plates.

Standard lengths are 400, 500 and 600mm. The travel time is 1.5 seconds with a lifting height of 20 mm, cycle time is 4 seconds.

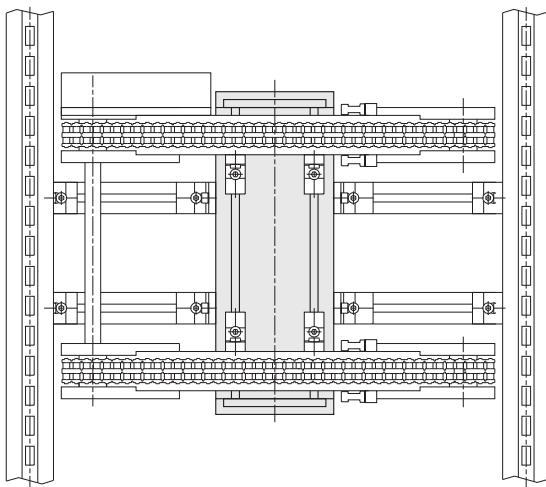
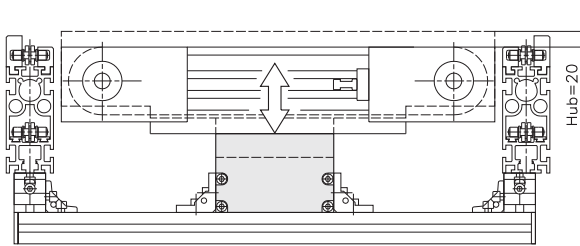

Application Used as lifting module for transfer conveyor.

Internal (flat cylinder):

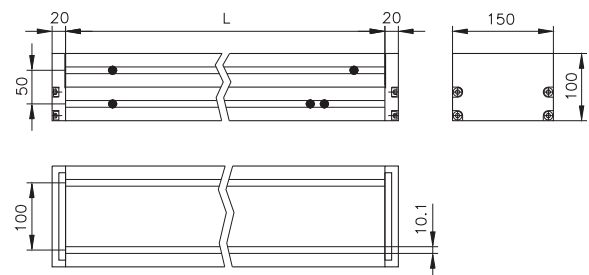





Ident Nr: **B28.00.001**

Please specify length when ordering.

Technical Data

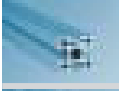

Contents Technical Data

| | | |
|--|--------------------------------------|-----|
|  | Standards, Norms and Calculations | 240 |
|  | Determining the Deflection Series 25 | 244 |
|  | Determining the Deflection Series 40 | 246 |
|  | Determining the Deflection Series 50 | 248 |
|  | Determining the Deflection Series 60 | 250 |
|  | Technical Data | 252 |

Standards, Norms and Calculations

Norms and Standards

mk profiles are extruded aluminum and are generally available in standard lengths of 5100 mm. All profiles are available cut to length. Longer lengths may also be available on request. All structural profiles are chemically etched per E6, whereby surface grooves and roughnesses are removed. As a surface treatment the profiles are

anodized with appx. 10 µm of tint C0 (natural). This surface finish is alkaline and acid resistant (alkalines to PH 9.5 and acids to PH 4). The following tables show the allowable dimensional deviations from standard with maximum values indicated.

Alloys of mk Profiles

per DIN EN 755 and DIN EN 12020

mk uses primarily two alloys for all profile series. For Series 25 and 40 AlMgSi 0.5 F25, for Series 50 and 60, AlMgSi 0.7 F28, which has a more than 7% higher strength.

| Material according to DIN EN 573-3 | | | EN AW 6063 T66 AlMg0.7Si | EN AW 6005A T6 AlSiMg(A) |
|---|-------|------------------------|-----------------------------|-----------------------------|
| Material according to DIN 1725-1 | | | AlMgSi 0.5 F25 | AlMgSi 0.7 F27 |
| Material number | | | 3.3206.72 | 3.3210.71 |
| Density | ρ | g/cm ³ | 2.7 | 2.7 |
| Elastic modulus | E | N/mm ² | 70,000 | 70,000 |
| Elastic modulus | Rm | N/mm ² | 245 | 255 |
| 0.2%-elastic limit | Rp0.2 | N/mm ² | 200 | 215 |
| Reduction of Area | A5 | % | 8 | 8 |
| Brinell hardness | HB | | 80 | 85 |
| Coefficient of thermal expansion (up to 20°C/to 293°K) | αl | 1/K | 21.8*10 ⁻⁶ | 21.8*10 ⁻⁶ |
| (20°-100°C/293°-373°K) | | | 23.2*10 ⁻⁶ | 23.2*10 ⁻⁶ |
| Thermal conductivity | λ | W/(m*K) | 200-220 | 180-220 |
| Electrical conductivity (20°C/293°K) | κ | m/(Ω*mm ²) | 28-34 | 26-32 |

Squareness of cross-section

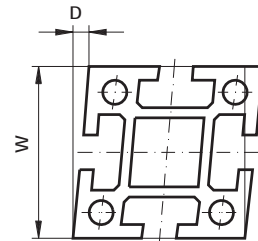

| Width W Range | | Deviation from square (mm) D |
|------------------|-----|---------------------------------|
| over | to | |
| - | 40 | 0.20 |
| 40 | 60 | 0.30 |
| 60 | 90 | 0.40 |
| 90 | 120 | 0.45 |
| 120 | 150 | 0.55 |
| 150 | 180 | 0.65 |
| 180 | 210 | 0.70 |

Norms and Standards

Straightness in extruded direction

The deviation h_1 for a given length may not exceed the chart values. In addition, any 300 mm long section may not exceed 0.3 mm from true. All values in mm.

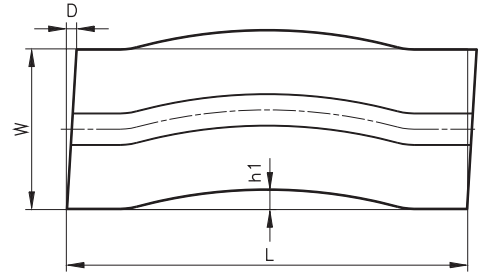

| Length L | to 1000 | to 2000 | to 3000 | to 4000 | to 5000 | to 6000 | over 6000 |
|-----------------|---------|---------|---------|---------|---------|---------|-----------|
| Tolerance h_1 | 0.7 | 1.3 | 1.8 | 2.2 | 2.6 | 3.0 | 3.5 |

Tolerances for cut-to-length profiles

| Length L | to 500 | to 1000 | to 2000 | to 6000 |
|-----------|--------|---------|---------|---------|
| Tolerance | ± 0.5 | ± 0.8 | ± 1.2 | ± 2.0 |

| Width W | to 50 | to 100 | to 200 | to 300 |
|-------------------|--------|--------|--------|--------|
| Angle tolerance D | 0.2 mm | 0.4 mm | 0.8 mm | 1.2 mm |

In case the above described length tolerance is not sufficient it is possible to improve accuracy by mechanical milling.

Twist

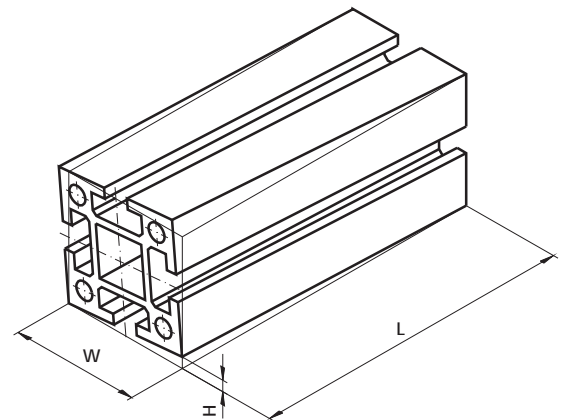

| Width W | | Allowable twist H per Length L | | | | | | | per quote |
|---------|-----|--------------------------------|-------------------|-------------------|-------------------|-------------------|-------------------|-----------|-----------|
| over | to | to 1000 | over 1000 to 2000 | over 2000 to 3000 | over 3000 to 4000 | over 4000 to 5000 | over 5000 to 6000 | over 6000 | |
| - | 25 | 1.0 | 1.5 | 1.5 | 2.0 | 2.0 | 2.0 | | per quote |
| 25 | 50 | 1.0 | 1.2 | 1.5 | 1.8 | 2.0 | 2.0 | | |
| 50 | 75 | 1.0 | 1.2 | 1.2 | 1.5 | 2.0 | 2.0 | | |
| 75 | 100 | 1.0 | 1.2 | 1.5 | 2.0 | 2.2 | 2.5 | | |
| 100 | 125 | 1.0 | 1.5 | 1.8 | 2.2 | 2.5 | 3.0 | | |
| 125 | 150 | 1.2 | 1.5 | 1.8 | 2.2 | 2.5 | 3.0 | | |
| 150 | 200 | 1.5 | 1.8 | 2.2 | 2.6 | 3.0 | 3.5 | | |
| 200 | 300 | 1.8 | 2.5 | 3.0 | 3.5 | 4.0 | 4.5 | | |

Standards, Norms and Calculations

Relative deflection of base profiles

Load at Center
Maximum Stress:

$$M_{bmax} = \frac{F \cdot L}{4} \quad \sigma_b = \frac{M_{bmax}}{W_{x,y}} \quad S = \frac{R_{p0.2}}{\sigma_b}$$

Maximum Deflection

$$f = \frac{F \cdot L^3}{48 \cdot E \cdot I_{x,y}}$$

$R_{p0.2} =$
195 N/mm²
(AlMgSi 0.5 F25)

225 N/mm²
(AlMgSi 0.7 F28)

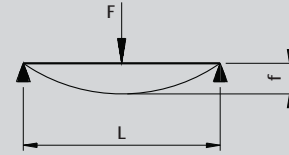

Uniform Load
Maximum Stress:

$$M_{bmax} = \frac{q \cdot L^2}{8} \quad \sigma_b = \frac{M_{bmax}}{W_{x,y}} \quad S = \frac{R_{p0.2}}{\sigma_b}$$

Maximum Deflection

$$f = \frac{5}{384} \cdot \frac{q \cdot L^4}{E \cdot I_{x,y}}$$

$R_{p0.2} =$
195 N/mm²
(AlMgSi 0.5 F25)

225 N/mm²
(AlMgSi 0.7 F28)

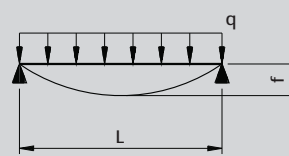

Deflection comparison of Base Profiles – Series 25, 40, 50 and 60

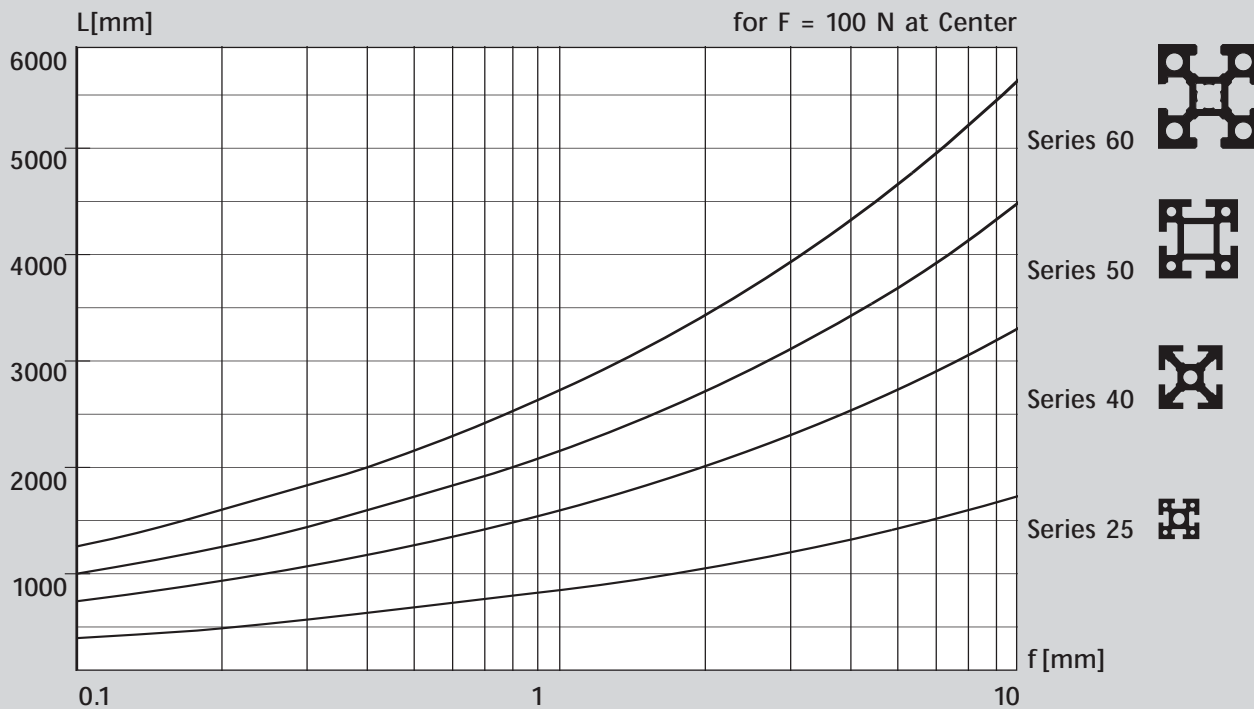

Determining the Deflection of the System Profiles

The Deflection of the mk Structural Profiles can be ascertained mathematically as well as through the use of the ensuing logarithmic charts. Using the graphs is the fastest way of determining deflection. This method can also help recommend a profile given allowable deflection under a particular length/load situation. Using the given equation is recommended to determine exact deflection.

The examples shown here are limited to profiles supported at both ends with

- a single load at the center
- an evenly distributed load

As the weight of the beam itself can be considered an evenly distributed load, the deflection due to this can be taken from the graph "Deflection due to evenly distributed load", or calculated as shown in the example equation.

To determine the total deflection of overlapping profiles the deflection of the individual beams may be added (note to include the applied load as well as the weight of the beam).

Consider the following application:

A machine frame is constructed using Profile mk 2025.02, oriented vertically, as the top beams.

- This frame is 1585 mm long on one side.
- A surface plate is placed on these beams, which exerts a force of 237 N/m (distributed load) on this profile.
- A piece of equipment is placed onto the surface plate, which exerts an additional force of 750 N (point load) on the beam.

This example is shown in the calculations at right.

Caution!

Die examples shown are only valid for

- in relation to beam lengths – relatively small deflections!

Example

Deflection calculation using point load and weight of beam

Load: $F_{\text{Point}} = 250 \text{ N}$
 $q_{\text{Distr.}} = 237 \text{ N/m}$
 $L = 1585 \text{ mm}$
 Profile: mk 2025.02 (25 x 50 – vertical)
 Using: $I_x = 12.19 \text{ cm}^4 \hat{=} 121900 \text{ mm}^4$
 $q_{\text{Beam}} = 1.35 \text{ kg/m} \hat{=} 13.2 \text{ N/m}$
 $E = 70000 \text{ N/mm}^2$ (E-Modulus Alu)

Deflection due to point load

- using the graph on page 244-250

$$f_{\text{Point}} = 2.4 \text{ mm}$$

- using the formula

$$f_{\text{Point}} = \frac{F_{\text{Point}} \cdot L^3}{48 \cdot E \cdot I_x} = \frac{250 \text{ N} \cdot 1585^3 \text{ mm}^3}{48 \cdot 70000 \text{ N/mm}^2 \cdot 121900 \text{ mm}^4}$$

$$f_{\text{Point}} = 2.43 \text{ mm}$$

Deflection due to distributed weight of beam

- using the graph on page 245-251, with $q = q_{\text{Distr.}} + q_{\text{Beam}} = 250 \text{ N/m}$

$$f_{\text{Distr.}} = 2.4 \text{ mm}$$

- using the formula

$$f_{\text{Distr.}} = \frac{5}{384} \cdot \frac{q \cdot L^4}{E \cdot I_x} = \frac{5}{384} \cdot \frac{0.25 \text{ N/mm} \cdot 1585^4 \text{ mm}^4}{70000 \text{ N/mm}^2 \cdot 121900 \text{ mm}^4}$$

$$f_{\text{Distr.}} = 2.4 \text{ mm}$$

Total Deflection

$$f_{\text{Total}} = f_{\text{Point}} + f_{\text{Distr.}} = 2.4 \text{ mm} + 2.4 \text{ mm}$$

$$f_{\text{Total}} = 4.8 \text{ mm}$$

Caution!

Ensure correct use of units.

To be safe, compare calculations with the examples shown above.

Determining the Deflection

System 2000 Series 25

Deflection of Load at Center Series 25

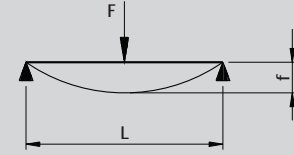

Example:
Profile mk 2025.02 (high)
 $I = 12.19 \text{ cm}^4$
 $F = 250 \text{ N}$
 $L = 1585 \text{ mm}$
 $f = 2.4 \text{ mm}$

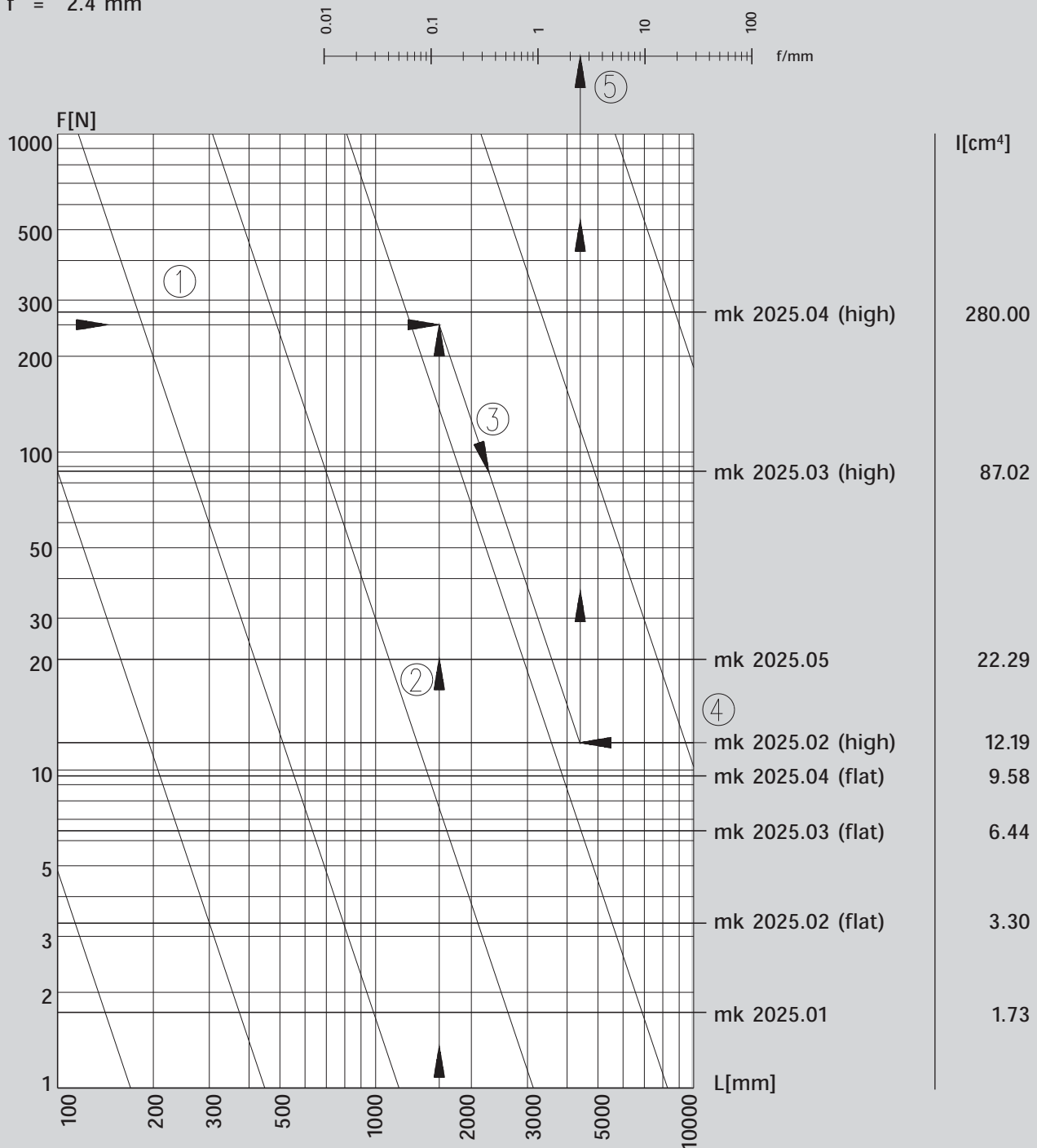

Deflection of Distributed Load Series 25



Example:
 Profile mk 2025.02 (high)
 $I = 12.19 \text{ cm}^4$
 $F = 250 \text{ N}$
 $L = 1585 \text{ mm}$
 $f = 2.4 \text{ mm}$

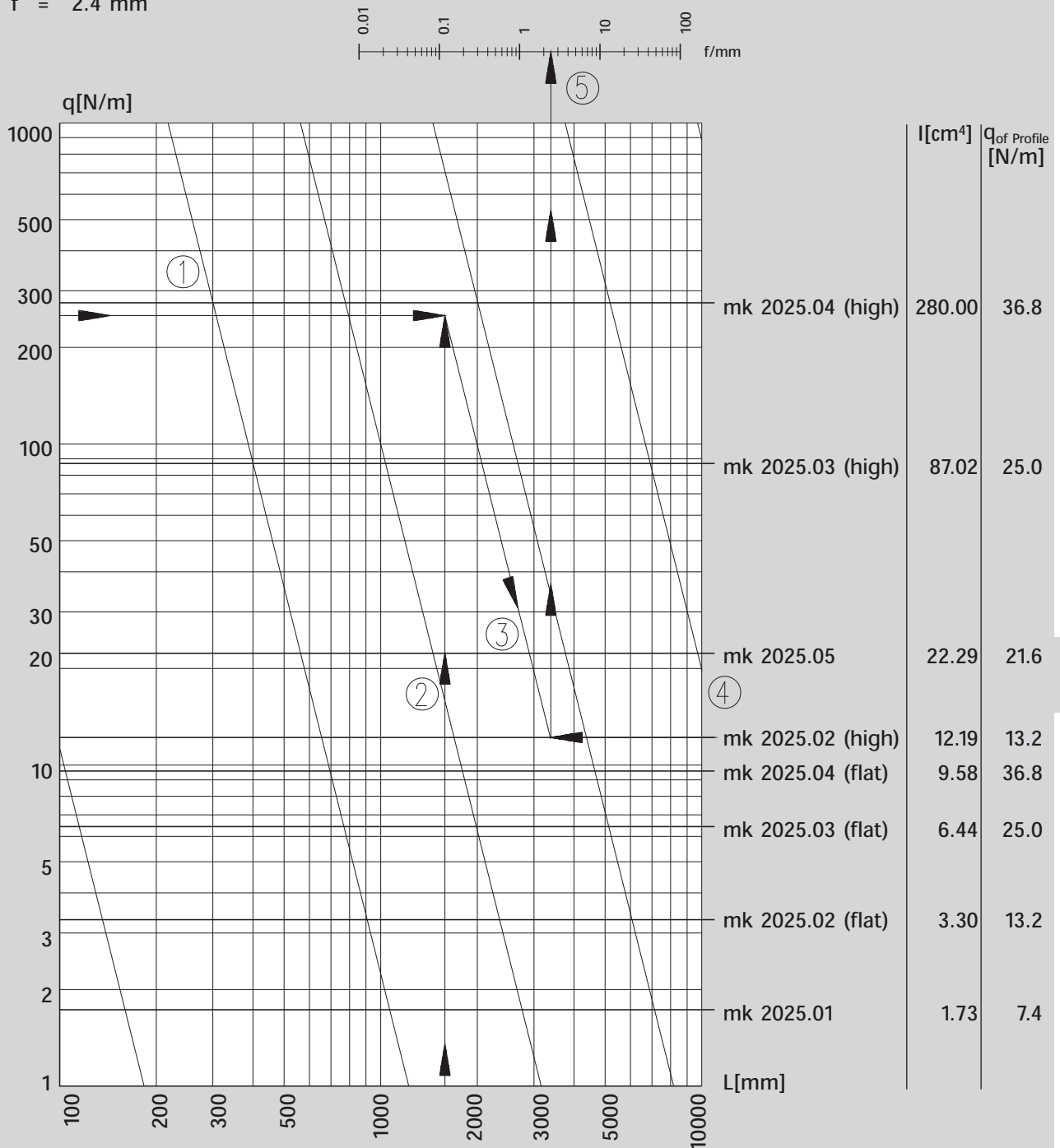
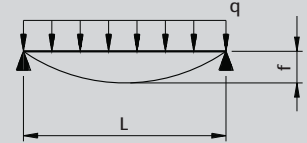

Determining the Deflection

System 2000 Series 40

Deflection of Load at Center
Series 40

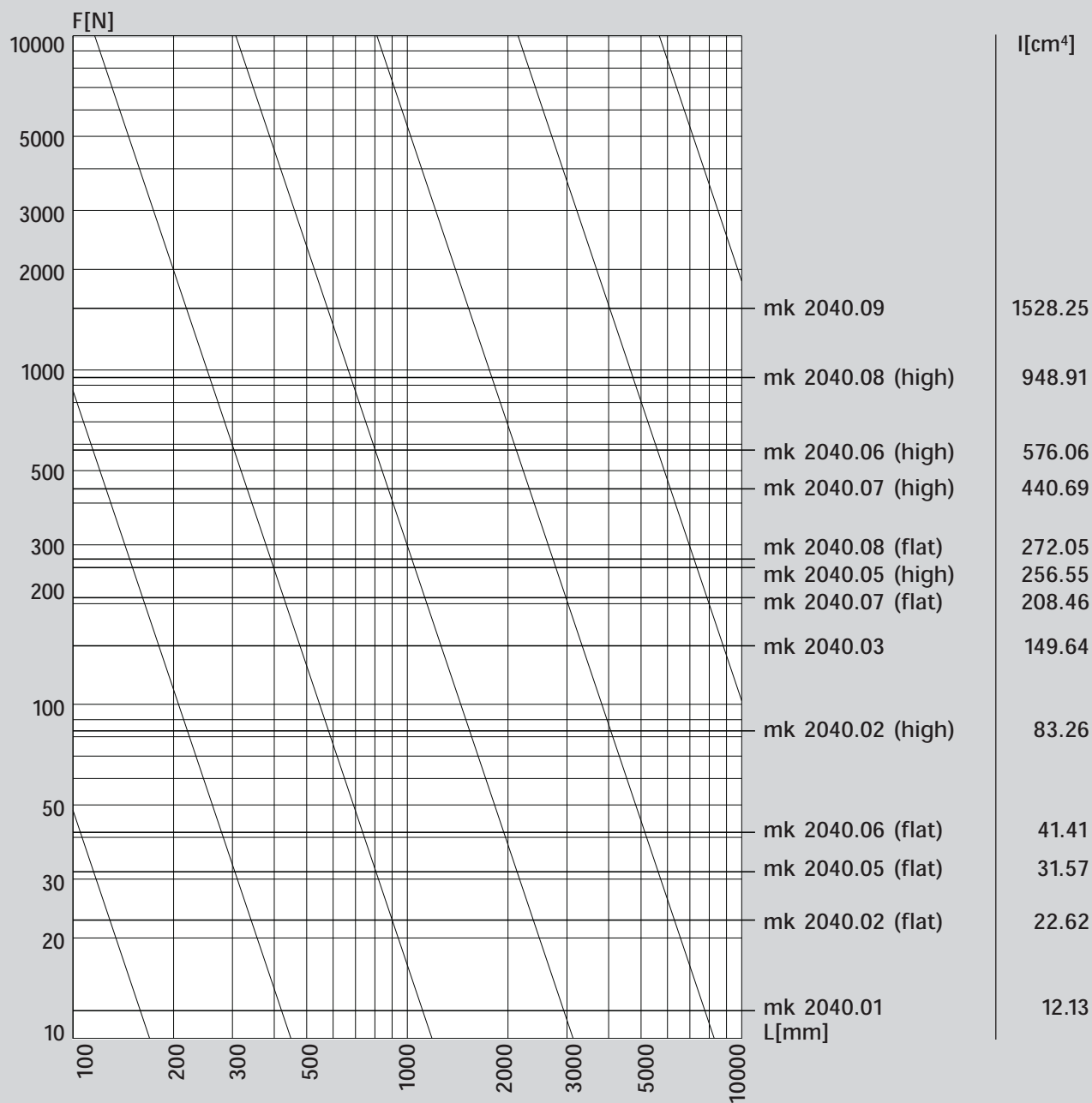
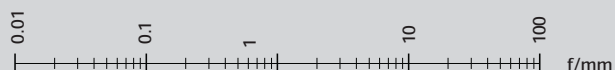
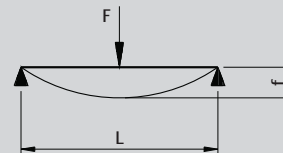

Deflection of Distributed Load Series 40

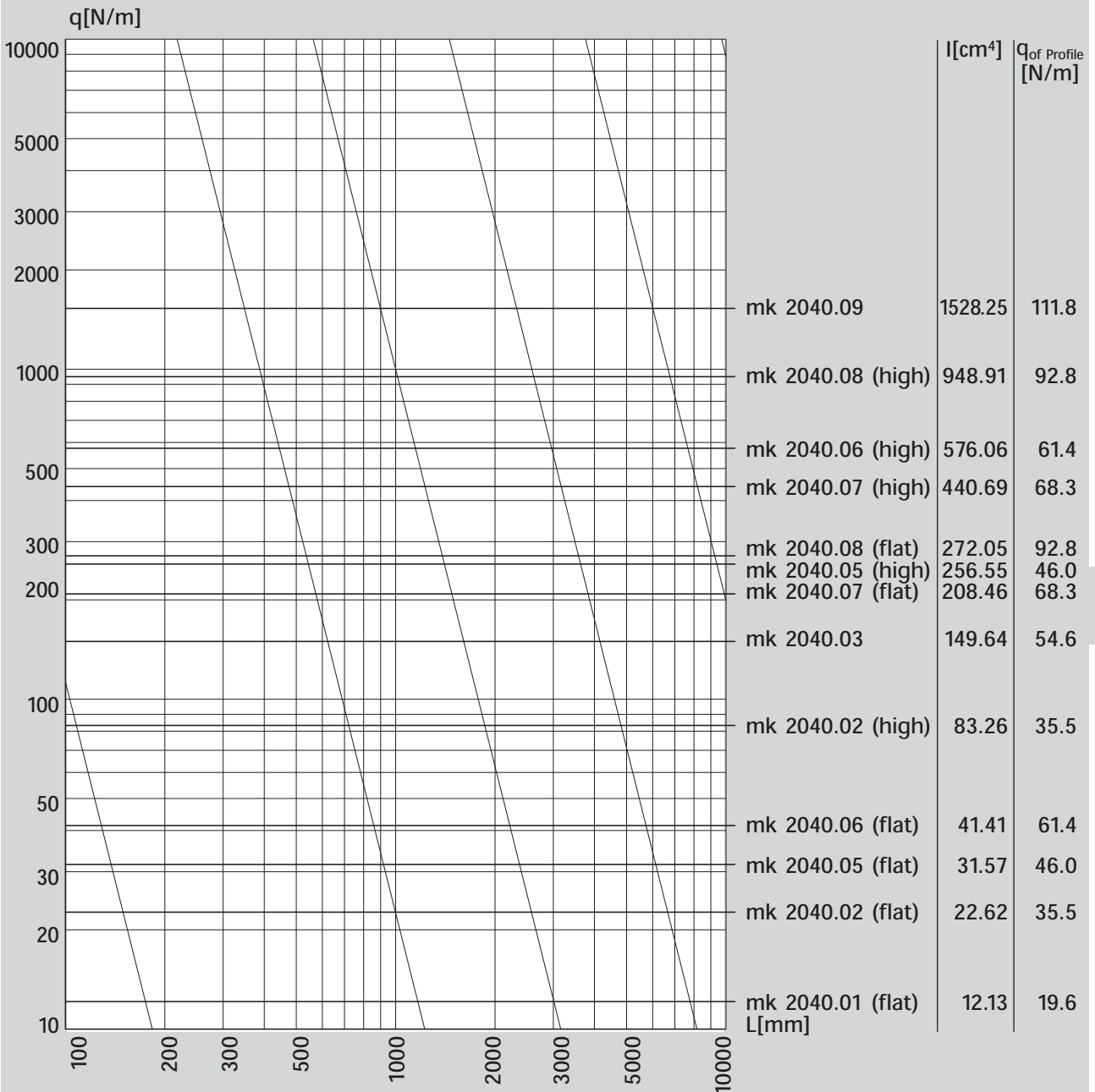
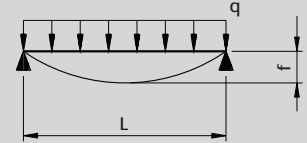

Determining the Deflection

System 2000 Series 50

Deflection of Load at Center
Series 50

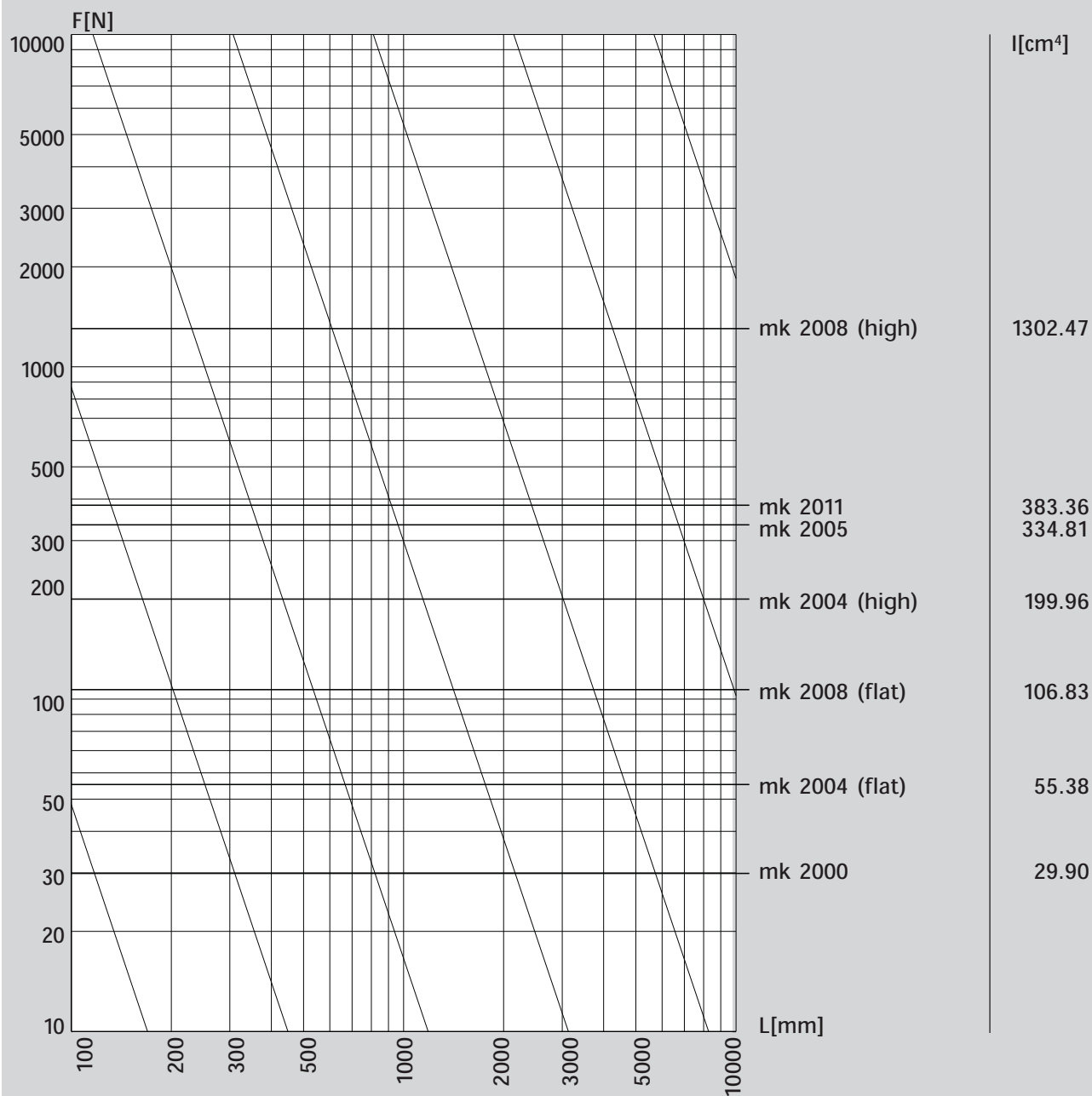
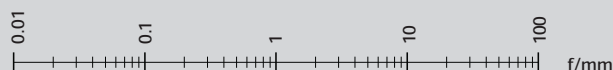
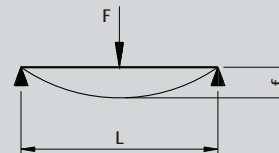

Deflection of Distributed Load
 Series 50

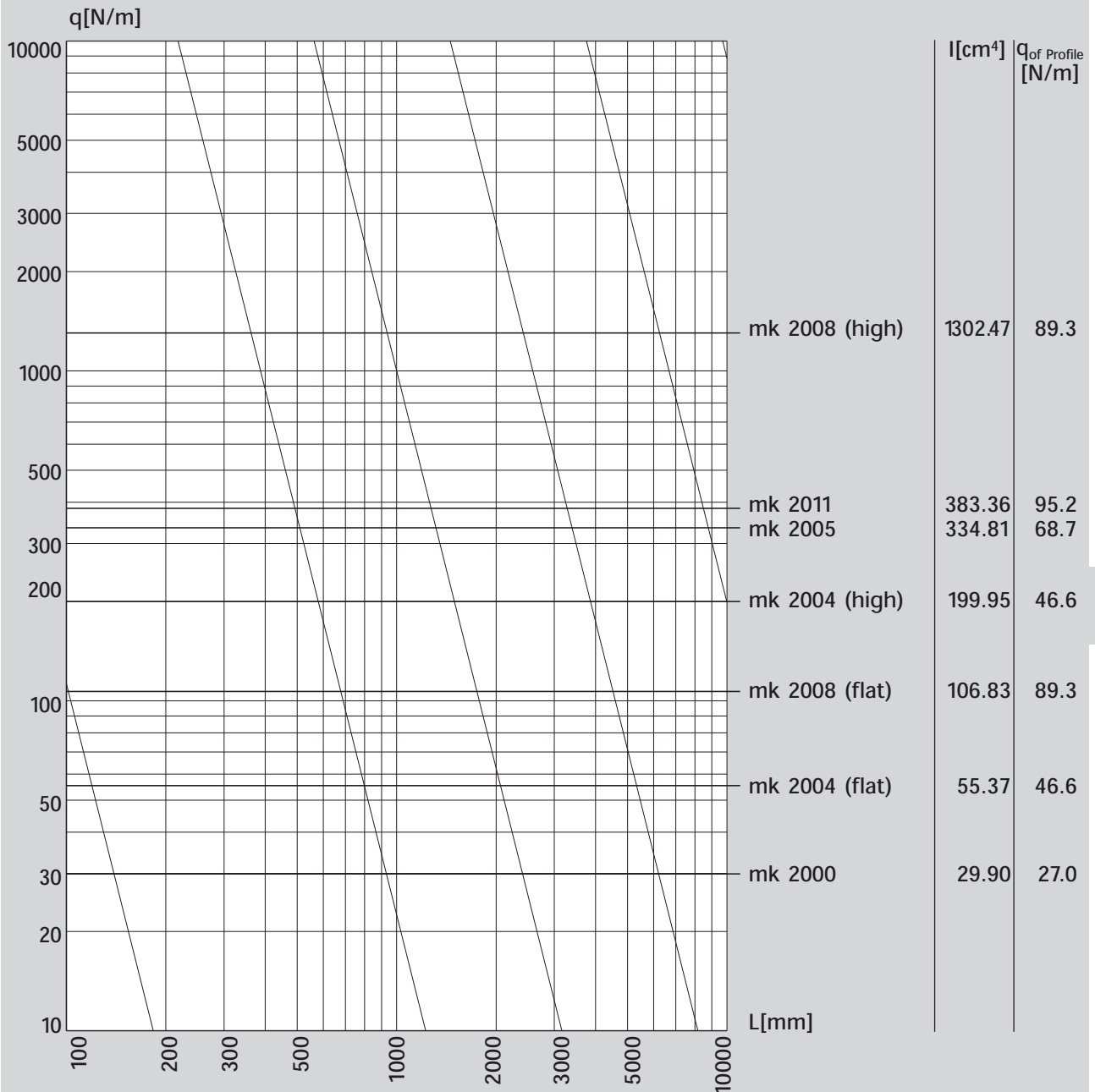
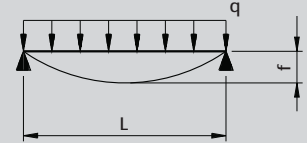

Determining the Deflection

System 2000 Series 60

Deflection of Load at Center
Series 60

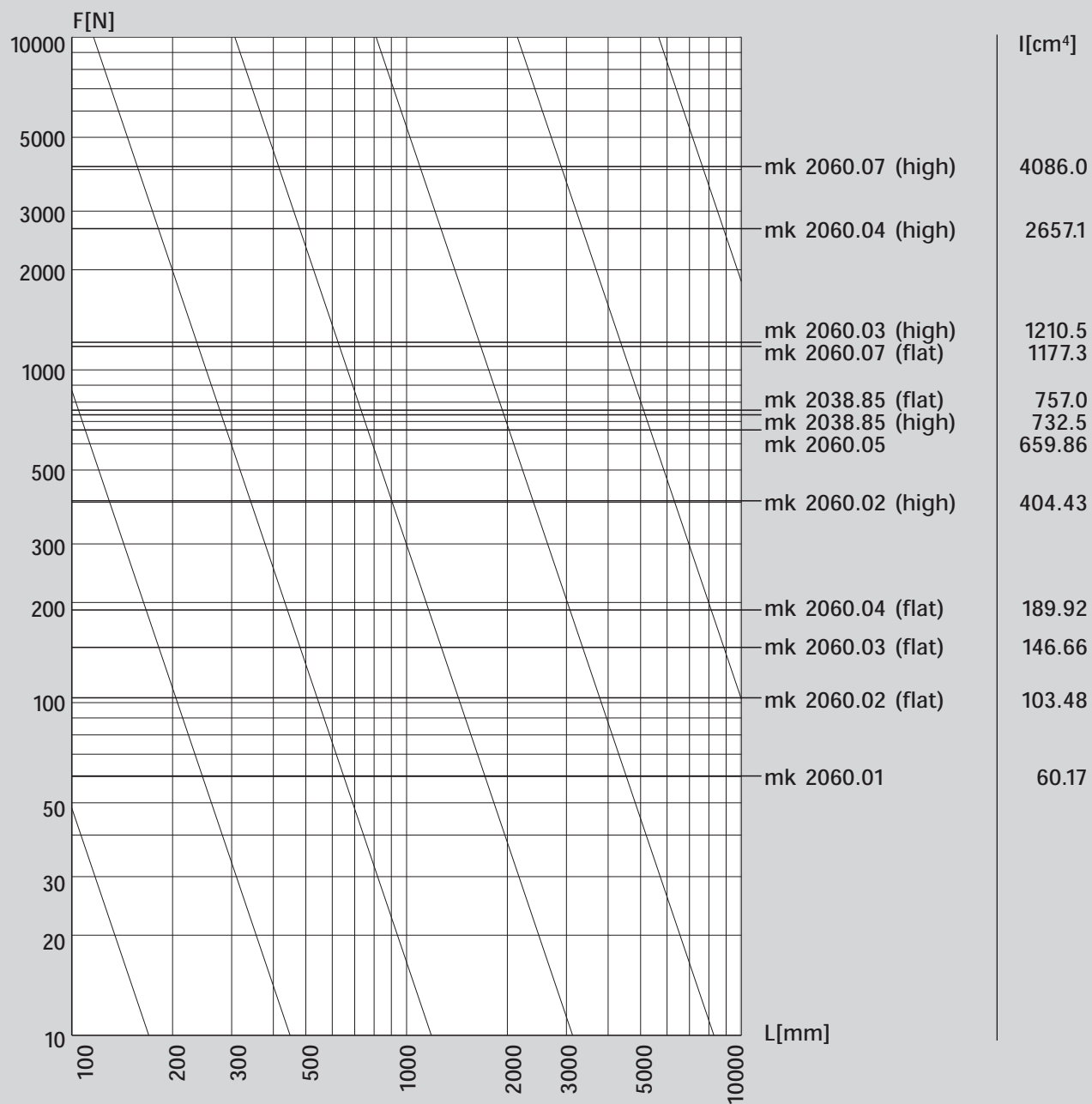
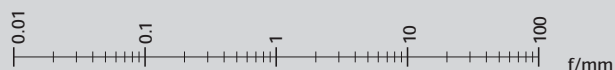
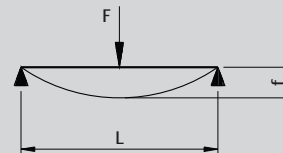
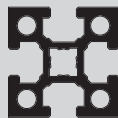



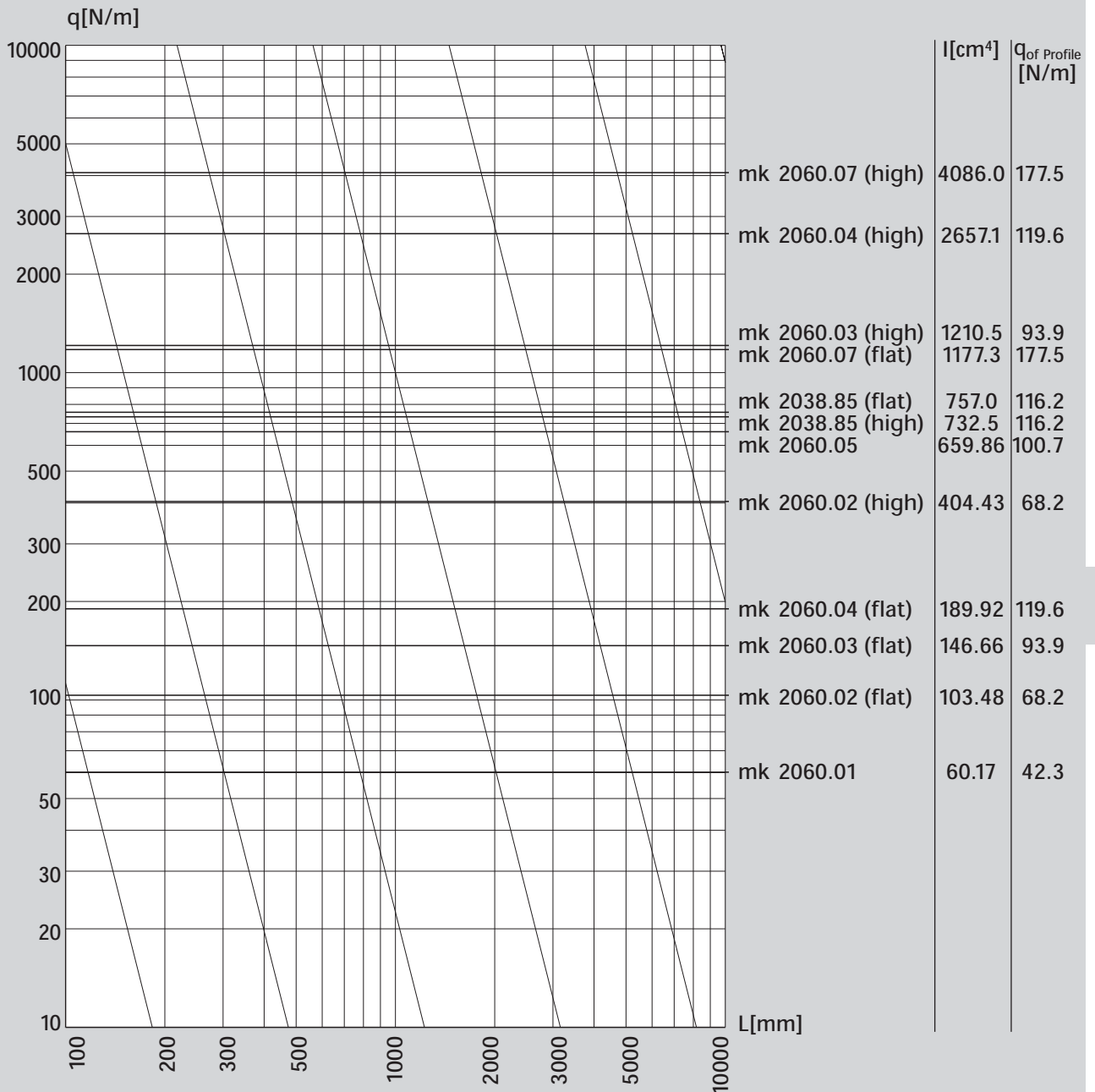
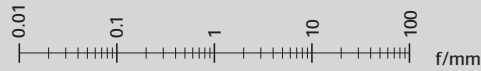
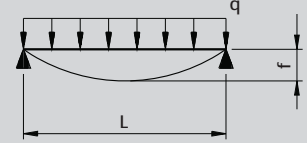





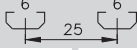

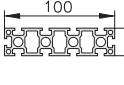
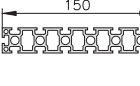









Deflection of Distributed Load
 Series 60

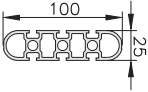

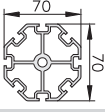
Technical Data

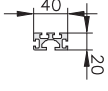
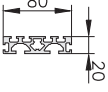
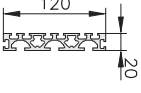
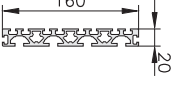
Structural Profiles

| Profile | Profile Symbol | Surface area | Mass per length | Moment of inertia | | Section modulus | | Page |
|--|---|----------------------|-----------------|-----------------------------------|-----------------------------------|-----------------------------------|-----------------------------------|------|
| | | A [mm ²] | m [kg/m] | I _x [cm ⁴] | I _y [cm ⁴] | W _x [cm ³] | W _y [cm ³] | |
| Profile Series 25  | | | | | | | | |
| mk 2025.01 |  | 279 | 0.75 | 1.73 | 1.73 | 1.38 | 1.38 | 31 |
| mk 2025.02 |  | 501 | 1.35 | 12.19 | 3.3 | 4.87 | 2.64 | 31 |
| mk 2025.03 |  | 945 | 2.55 | 87.02 | 6.44 | 17.4 | 5.15 | 31 |
| mk 2025.04 |  | 1390 | 3.75 | 280 | 9.58 | 37.33 | 7.66 | 31 |
| mk 2025.05 |  | 816 | 2.21 | 22.3 | 22.3 | 8.9 | 8.9 | 31 |
| mk 2025.31 |  | 284 | 0.77 | 1.73 | 1.62 | 1.42 | 1.29 | 32 |
| mk 2025.35 |  | 275 | 0.75 | 1.71 | 1.68 | 1.38 | 1.34 | 32 |
| mk 2025.38 |  | 290 | 0.79 | 1.52 | 1.48 | 1.27 | 1.25 | 32 |
| mk 2025.37 |  | 267 | 0.73 | 1.32 | 1.28 | 1.14 | 1.12 | 33 |
| mk 2025.32 |  | 475 | 1.29 | 3.22 | 12.03 | 2.6 | 4.81 | 33 |
| mk 2025.36 |  | 462 | 1.25 | 3.12 | 11.88 | 2.58 | 4.81 | 33 |
| mk 2025.39 |  | 407 | 1.1 | 2.05 | 9.44 | 1.81 | 3.77 | 33 |
| mk 2025.25 |  | 482 | 1.3 | 9.99 | 9.99 | 3.76 | 3.76 | 33 |

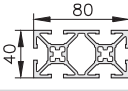
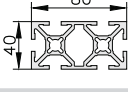
| Profile | Profile Symbol | Surface area | Mass per length | Moment of inertia | | Section modulus | | Page |
|---|---|----------------------|-----------------|-----------------------------------|-----------------------------------|-----------------------------------|-----------------------------------|------|
| | | A [mm ²] | m [kg/m] | I _x [cm ⁴] | I _y [cm ⁴] | W _x [cm ³] | W _y [cm ³] | |
| <i>Profile Series 25</i>  | | | | | | | | |
| mk 2025.22 |  | 837 | 2.26 | 64.26 | 5.84 | 12.95 | 4.67 | 34 |
| mk 2025.20 |  | 783 | 2.12 | 15.51 | 15.52 | 6.2 | 5.45 | 34 |
| mk 2025.21 |  | 1100 | 2.98 | 43.62 | 43.62 | 12.46 | 12.46 | 34 |
| <i>Adapter Profile Series 25/40</i>  | | | | | | | | |
| mk 2025.41 |  | 377 | 1.02 | 6.2 | 1.49 | 3.1 | 1.39 | 35 |
| mk 2025.42 |  | 717 | 1.94 | 42.51 | 2.97 | 10.63 | 2.88 | 35 |
| mk 2025.43 |  | 1060 | 2.86 | 136.21 | 4.44 | 22.7 | 4.37 | 35 |
| mk 2025.44 |  | 1400 | 3.77 | 314.51 | 5.9 | 39.29 | 5.86 | 35 |
| <i>Profile Series 40</i>  | | | | | | | | |
| mk 2040.31 |  | 561 | 1.50 | 9.69 | 9.69 | 4.84 | 4.84 | 37 |
| mk 2040.40 |  | 606 | 1.64 | 10.52 | 10.52 | 5.26 | 5.26 | 37 |
| mk 2040.01 |  | 742 | 2.00 | 12.13 | 12.13 | 6.06 | 6.06 | 37 |
| mk 2040.52 |  | 988 | 2.67 | 64.10 | 17.50 | 16.00 | 8.76 | 37 |
| mk 2040.41 |  | 1160 | 2.85 | 68.89 | 18.67 | 17.22 | 9.33 | 38 |

Technical Data

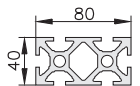
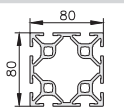
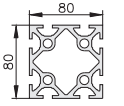
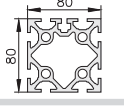
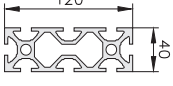
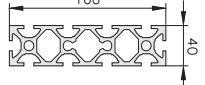
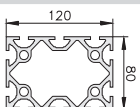
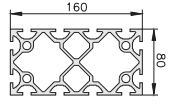
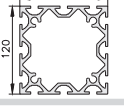
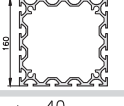
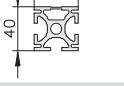
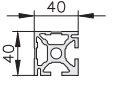
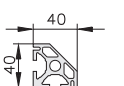

Structural Profiles

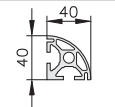
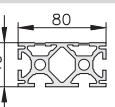
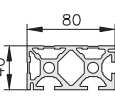
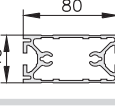
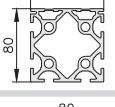
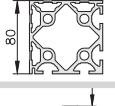
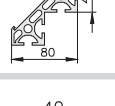
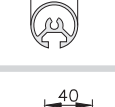
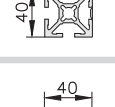
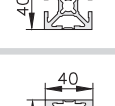
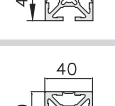
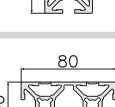
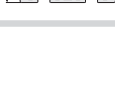
| Profile | Profile Symbol | Surface area | Mass per length | Moment of inertia | | Section modulus | | Page |
|--|---|----------------------|-----------------|-----------------------------------|-----------------------------------|-----------------------------------|-----------------------------------|------|
| | | A [mm ²] | m [kg/m] | I _x [cm ⁴] | I _y [cm ⁴] | W _x [cm ³] | W _y [cm ³] | |
| Profile Series 40  | | | | | | | | |
| mk 2040.02 |  | 1340 | 3.62 | 83.26 | 22.62 | 20.84 | 11.31 | 38 |
| mk 2040.45 |  | 1760 | 4.75 | 127.89 | 127.89 | 31.94 | 31.94 | 38 |
| mk 2040.03 |  | 2060 | 5.57 | 149.64 | 149.64 | 37.41 | 37.41 | 38 |
| mk 2040.73 |  | 2110 | 5.72 | 150.00 | 150.00 | 37.10 | 37.40 | 38 |
| mk 2040.05 |  | 1740 | 4.69 | 256.55 | 31.57 | 43.75 | 15.78 | 38 |
| mk 2040.06 |  | 2320 | 6.26 | 576.06 | 41.41 | 72.01 | 20.70 | 38 |
| mk 2040.07 |  | 2580 | 6.96 | 440.69 | 208.46 | 73.44 | 52.11 | 39 |
| mk 2040.08 |  | 3500 | 9.46 | 948.91 | 272.05 | 118.62 | 68.01 | 39 |
| mk 2040.10 |  | 3060 | 8.26 | 585.21 | 585.21 | 97.51 | 97.51 | 39 |
| mk 2040.09 |  | 4220 | 11.40 | 1528.25 | 1528.25 | 191.03 | 191.03 | 39 |
| mk 2040.21 |  | 685 | 1.84 | 11.00 | 10.21 | 5.42 | 5.10 | 40 |
| mk 2040.11 |  | 696 | 1.88 | 11.13 | 11.13 | 5.50 | 5.50 | 40 |
| mk 2040.14 |  | 604 | 1.62 | 8.30 | 8.30 | 4.75 | 4.75 | 40 |

| Profile | Profile Symbol | Surface area | Mass per length | Moment of inertia | | Section modulus | | Page |
|--|---|----------------------|-----------------|-----------------------------------|-----------------------------------|-----------------------------------|-----------------------------------|------|
| | | A [mm ²] | m [kg/m] | I _x [cm ⁴] | I _y [cm ⁴] | W _x [cm ³] | W _y [cm ³] | |
| <i>Profile Series 40</i>  | | | | | | | | |
| mk 2040.15 |  | 561 | 1.51 | 7.85 | 7.85 | 4.54 | 4.54 | 40 |
| mk 2040.22 |  | 1270 | 3.43 | 21.53 | 75.54 | 10.72 | 18.89 | 41 |
| mk 2040.12 |  | 1270 | 3.43 | 21.39 | 77.91 | 10.86 | 19.86 | 41 |
| mk 2040.24 |  | 832 | 2.25 | 16.60 | 66.07 | 8.30 | 16.34 | 41 |
| mk 2040.46 |  | 2020 | 5.44 | 145.08 | 145.56 | 35.63 | 36.38 | 41 |
| mk 2040.13 |  | 1970 | 5.32 | 141.92 | 141.92 | 36.05 | 36.05 | 41 |
| mk 2040.04 |  | 1340 | 3.61 | 71.82 | 71.82 | 18.80 | 18.80 | 41 |
| mk 2040.16 |  | 445 | 1.25 | 5.28 | 6.22 | 2.87 | 3.11 | 42 |
| mk 2040.93 |  | 634 | 1.72 | 11.00 | 11.00 | 5.40 | 5.40 | 42 |
| mk 2040.94 |  | 634 | 1.72 | 11.40 | 10.50 | 5.73 | 5.28 | 42 |
| mk 2040.95 |  | 647 | 1.75 | 11.00 | 11.40 | 5.41 | 5.74 | 43 |
| mk 2040.92 |  | 623 | 1.68 | 11.00 | 10.56 | 5.40 | 5.28 | 43 |
| mk 2040.100 |  | 1090 | 2.94 | 19.68 | 70.83 | 9.63 | 17.71 | 43 |

Technical Data

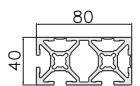
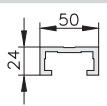
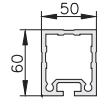
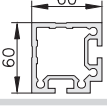
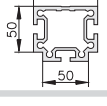
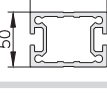
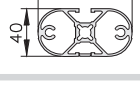
Structural Profiles

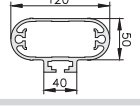
| Profile | Profile Symbol | Surface area | Mass per length | Moment of inertia | | Section modulus | | Page |
|--|---|----------------------|-----------------|-----------------------------------|-----------------------------------|-----------------------------------|-----------------------------------|------|
| | | A [mm ²] | m [kg/m] | I _x [cm ⁴] | I _y [cm ⁴] | W _x [cm ³] | W _y [cm ³] | |
| <i>Profile Series 40</i>  | | | | | | | | |
| mk 2040.101 |  | 1100 | 2.97 | 19.69 | 72.70 | 9.64 | 17.98 | 43 |
| mk 2040.37 |  | 426 | 1.17 | 2.74 | 14.65 | 1.09 | 9.73 | 47 |
| mk 2040.38 |  | 933 | 2.52 | 43.13 | 32.45 | 13.60 | 12.98 | 47 |
| mk 2040.39 |  | 1110 | 3.00 | 49.87 | 49.87 | 16.31 | 16.31 | 47 |
| mk 2040.74 |  | 1300 | 3.50 | 74.32 | 56.44 | 21.23 | 18.66 | 47 |
| mk 2040.75 |  | 1120 | 3.01 | 68.36 | 38.58 | 27.35 | 11.02 | 47 |
| mk 2040.23 |  | 785 | 2.12 | 42.60 | 12.00 | 10.70 | 5.90 | 48 |
| mk 2040.34 |  | 1310 | 3.56 | 139.67 | 24.15 | 23.53 | 12.08 | 48 |
| mk 2040.30 |  | 1620 | 4.36 | 242.23 | 67.65 | 40.20 | 19.84 | 48 |

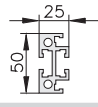
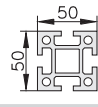
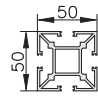
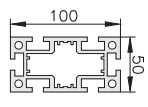
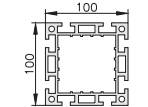
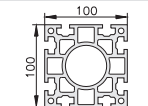
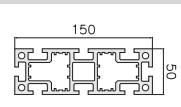
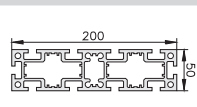
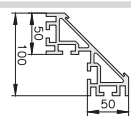
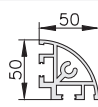
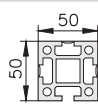
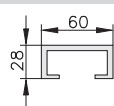
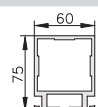
| Profile | Profile Symbol | Surface area | Mass per length | Moment of inertia | | Section modulus | | Page |
|--|---|----------------------|-----------------|-----------------------------------|-----------------------------------|-----------------------------------|-----------------------------------|------|
| | | A [mm ²] | m [kg/m] | I _x [cm ⁴] | I _y [cm ⁴] | W _x [cm ³] | W _y [cm ³] | |
| <i>Profile Series 50</i>  | | | | | | | | |
| mk 2001 |  | 542 | 1.49 | 14.26 | 2.67 | 5.70 | 1.82 | 55 |
| mk 2000 |  | 1080 | 2.85 | 29.90 | 29.90 | 11.96 | 11.96 | 55 |
| mk 2002 |  | 693 | 1.75 | 19.56 | 19.56 | 7.83 | 7.83 | 55 |
| mk 2004 |  | 1810 | 4.87 | 199.96 | 55.38 | 39.99 | 22.15 | 55 |
| mk 2005 |  | 2650 | 7.00 | 334.81 | 334.81 | 66.96 | 66.96 | 56 |
| mk 2011 |  | 3670 | 9.70 | 383.36 | 383.36 | 76.67 | 76.67 | 56 |
| mk 2006 |  | 2600 | 7.00 | 597.00 | 80.50 | 79.70 | 32.10 | 56 |
| mk 2008 |  | 3370 | 9.09 | 1302.47 | 106.83 | 130.24 | 42.73 | 56 |
| mk 2072 |  | 1710 | 4.62 | 151.77 | 151.77 | 28.75 | 28.75 | 56 |
| mk 2003 |  | 762 | 2.00 | 14.01 | 14.01 | 6.49 | 6.49 | 56 |
| mk 2017 |  | 1120 | 3.03 | 30.60 | 31.30 | 12.10 | 12.50 | 57 |
| mk 2033 |  | 554 | 1.50 | 5.22 | 27.72 | 4.94 | 9.24 | 58 |
| mk 2031 |  | 1120 | 2.85 | 79.17 | 55.59 | 23.18 | 18.53 | 58 |

Technical Data

Structural Profiles

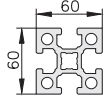
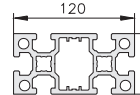
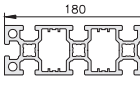
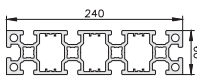
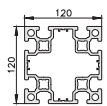
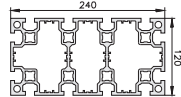
| Profile | Profile Symbol | Surface area | Mass per Length | Moment of inertia | | Section modulus | | Page |
|--|---|----------------------|-----------------|-----------------------------------|-----------------------------------|-----------------------------------|-----------------------------------|------|
| | | A [mm ²] | m [kg/m] | I _x [cm ⁴] | I _y [cm ⁴] | W _x [cm ³] | W _y [cm ³] | |
| Profile Series 60  | | | | | | | | |
| mk 2060.01 |  | 1600 | 4.31 | 60.17 | 60.17 | 20.05 | 20.05 | 61 |
| mk 2060.02 |  | 2580 | 6.95 | 404.43 | 103.48 | 67.34 | 34.49 | 61 |
| mk 2060.03 |  | 3540 | 9.57 | 1210.53 | 146.66 | 134.50 | 48.89 | 61 |
| mk 2060.04 |  | 4520 | 12.20 | 2657.18 | 189.92 | 221.18 | 63.28 | 62 |
| mk 2060.05 |  | 3800 | 10.30 | 659.86 | 659.86 | 109.85 | 109.85 | 62 |
| mk 2060.07 |  | 6700 | 18.10 | 4086.05 | 1177.39 | 340.50 | 169.23 | 62 |

Technical Data

Conversion table

| Length | | [mm] | [cm] | [m] | [in] | [ft] |
|--|---|--------------------|--------------------|-------------------|--------------------|--------------------|
| 1 Millimeter [mm] | = | 1 | 0.1 | 0.001 | 0.0394 | 0.0033 |
| 1 Centimeter [cm] | = | 10 | 1 | 0.01 | 0.3937 | 0.0328 |
| 1 Meter [m] | = | 1000 | 100 | 1 | 39.37 | 3.281 |
| 1 Inch ["/ in] | = | 25.4 | 2.54 | 0.0254 | 1 | 0.083 |
| 1 Foot [' / ft] | = | 304.8 | 30.48 | 0.3048 | 12 | 1 |
| Area | | [mm ²] | [cm ²] | [m ²] | [in ²] | [ft ²] |
| 1 Square millimeter [mm ²] | = | 1 | 0.01 | | 0.0016 | |
| 1 Square centimeter [cm ²] | = | 100 | 1 | 0.0001 | 0.155 | 0.0011 |
| 1 Square meter [m ²] | = | | 10000 | 1 | 1550 | 10.76 |
| 1 Square inch [in ²] | = | 645.6 | 6.452 | 0.0006 | 1 | 0.0069 |
| 1 Square foot [ft ²] | = | | 929 | 0.0929 | 144 | 1 |
| Volume | | [mm ³] | [cm ³] | [m ³] | [in ³] | [ft ³] |
| 1 Cubic millimeter [mm ³] | = | 1 | | 0.001 | | 0.000006 |
| 1 Cubic centimeter [cm ³] | = | 1000 | | 1 | | 0.061 |
| 1 Cubic inch [cu.in.] | = | | 163871 | 16.39 | | 1 |
| Moments of inertia | | [mm ⁴] | [cm ⁴] | [m ⁴] | [in ⁴] | [ft ⁴] |
| 1 Centimeter ⁴ [cm ⁴] | = | | 1 | | | 0.024 |
| 1 Inch ⁴ [in ⁴] | = | | 41.62 | | | 1 |
| Mass | | [kg] | [lb] | | | |
| 1 Kilogram [kg] | = | 1 | 2.205 | | | |
| 1 Pound [lb] | = | 0.4536 | 1 | | | |
| Force | | [N] | [lbf] | | | |
| 1 Newton [N] | = | 1 | 0.2248 | | | |
| 1 Pound-Force [lbf] | = | 4.448 | 1 | | | |
| Torque | | [Nm] | [lb-in] | | | |
| 1 Newton-Meter [Nm] | = | 1 | 8.851 | | | |
| 1 Pound-Inch [lb-in] | = | 0.113 | 1 | | | |
| Pressure | | [bar] | [psi] | | | |
| 1 Bar [bar] | = | 1 | 14.5 | | | |
| 1 Pound per square inch [psi] | = | 0.069 | 1 | | | |
| Power | | [kW] | [hp] | | | |
| 1 Kilowatt [kW] | = | 1 | 1.341 | | | |
| 1 Horsepower [hp] | = | 0.7457 | 1 | | | |

Design examples

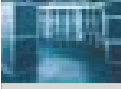

Contents Design examples

| | | |
|---|-----------------------------------|-----|
|  | Assembly instructions | 262 |
|  | Examples of Customer Applications | 272 |

Design examples

Assembly instructions

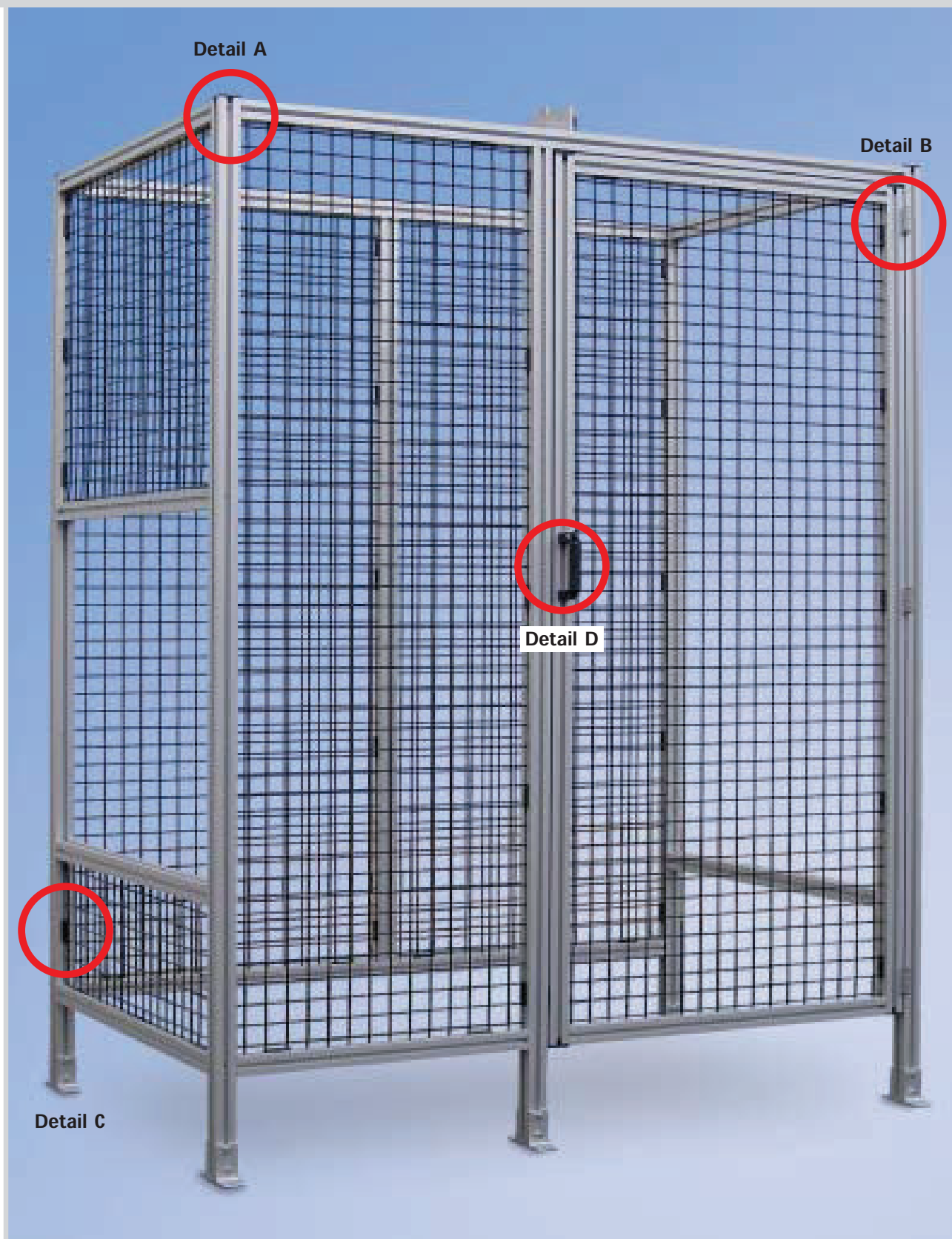

Detail A

| Page 109

Detail B

| Page 173

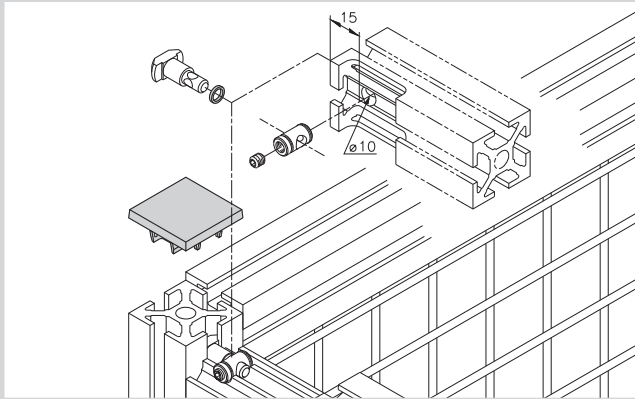

Tension Plug 40/1

B51.03.036

This connection requires a \varnothing 10mm thru-hole placed 15mm from the profile end. Use the series 40 drill fixture, **B51.03.005**, for this. After inserting the bolt into the hole the tension plug is inserted in the profile end and is secured by slightly tightening the set screw. The beam can now be positioned at any other point of the profile.

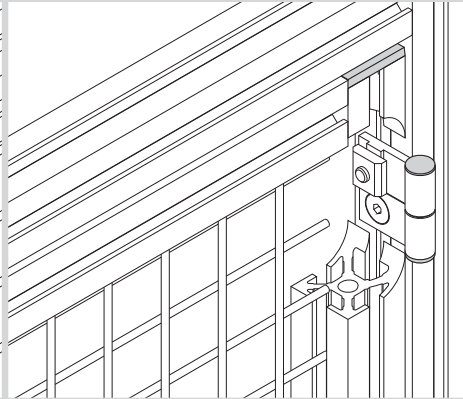

Hinge 40-1/40-1

B46.01.010

A hinge is mounted between two profiles with the flat head socket head cap screws (FH-SHCS) and nuts matching the profile series. The relevant mounting hardware is included with all hinges. The keys in the hinge leaves ensure parallel orientation of the elements.

Detail C

| Page 187

Detail D

| Page 177

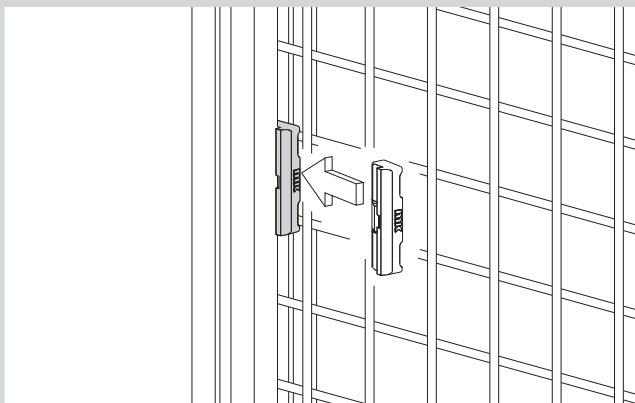

Fence Clip

mk 2544

The fence clip can be used to quickly fix wire mesh fencing in series 40 profiles. This is done by simply knocking the clip into the profile slot. To adequately secure the fencing in the profile frame the maximum distance of the fence clips from the corners should not exceed 200 mm and 520 mm from each other.

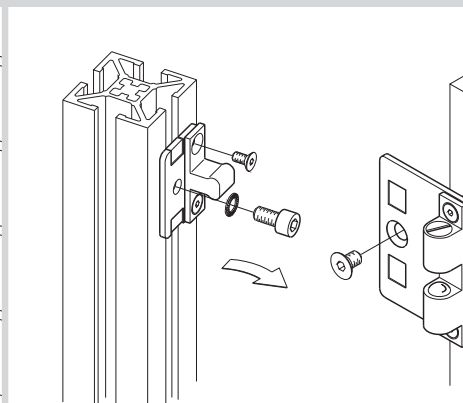

Ball latches

B68.02.101 for Door Gap 5 mm and
B68.02.102 for Door Gap 24 mm

Ball latches are simple and cost effective options for keeping doors shut which do not need to be locked with a key lock. They are easily mounted with screw-nut connections. All required hardware is included with the ball latches.

Design examples

Assembly instructions

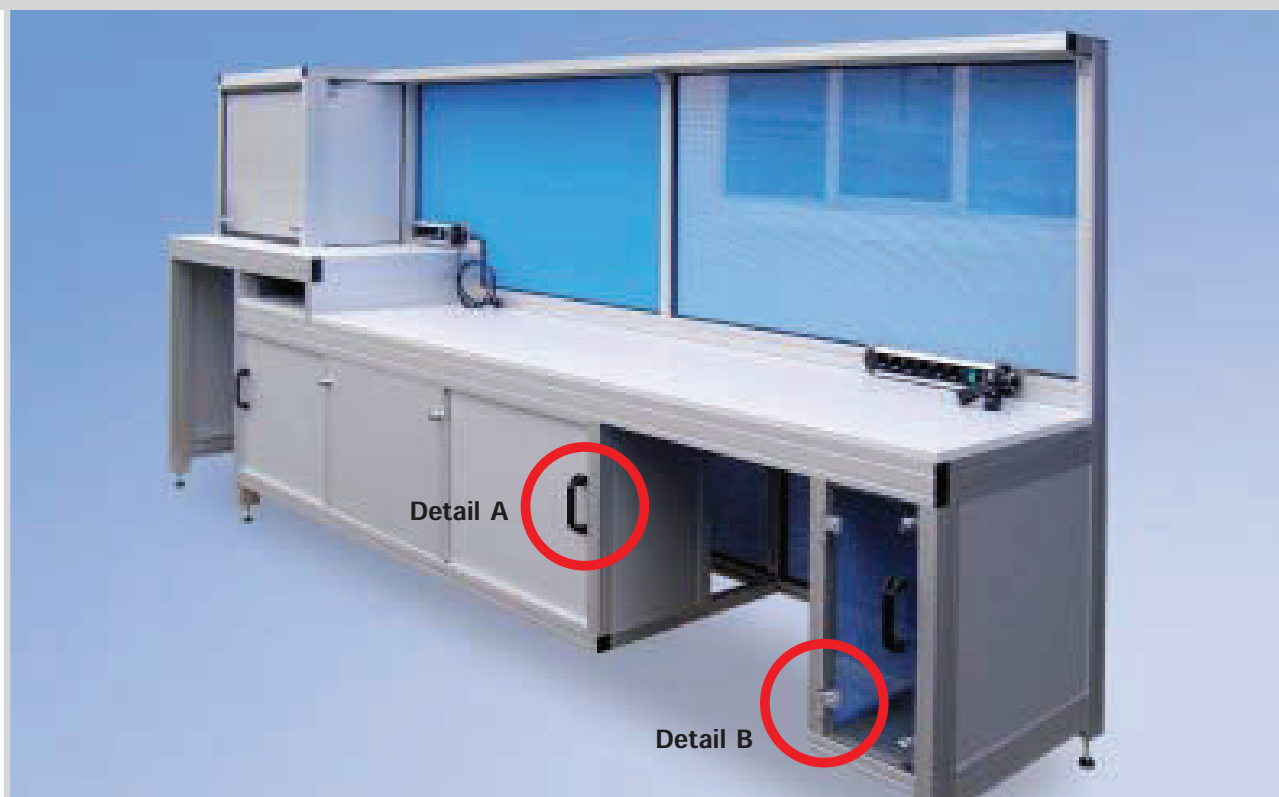

Detail A

! Page 170

Detail B

! Page 176

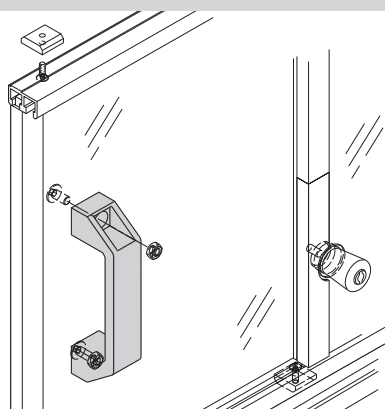

Handle

K11000020

The handle is attached directly onto the door panel using two M6x16 screws (**D0912616**) and two M6 hex nuts (**D09346**). To do this, drill two $\varnothing 6$ mm clearance holes, 152 mm apart, into the panel.

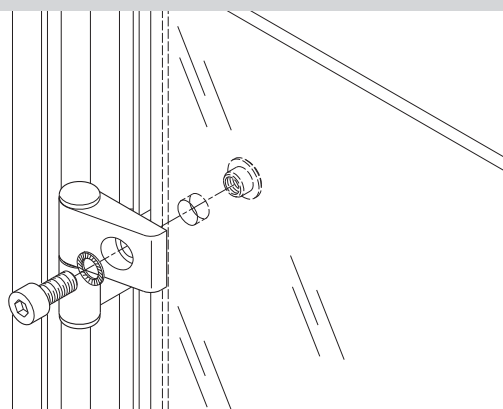

Hinge 40-1/40-3

B46.01.050

The hinge is mounted directly onto the 6 mm thick Polycarbonate panel. This requires a $\varnothing 10$ mm hole at a distance of 20 mm from the edge of the panel. All mounting hardware is included in the set of components. The key in the hinge arm ensures parallel orientation of the elements.

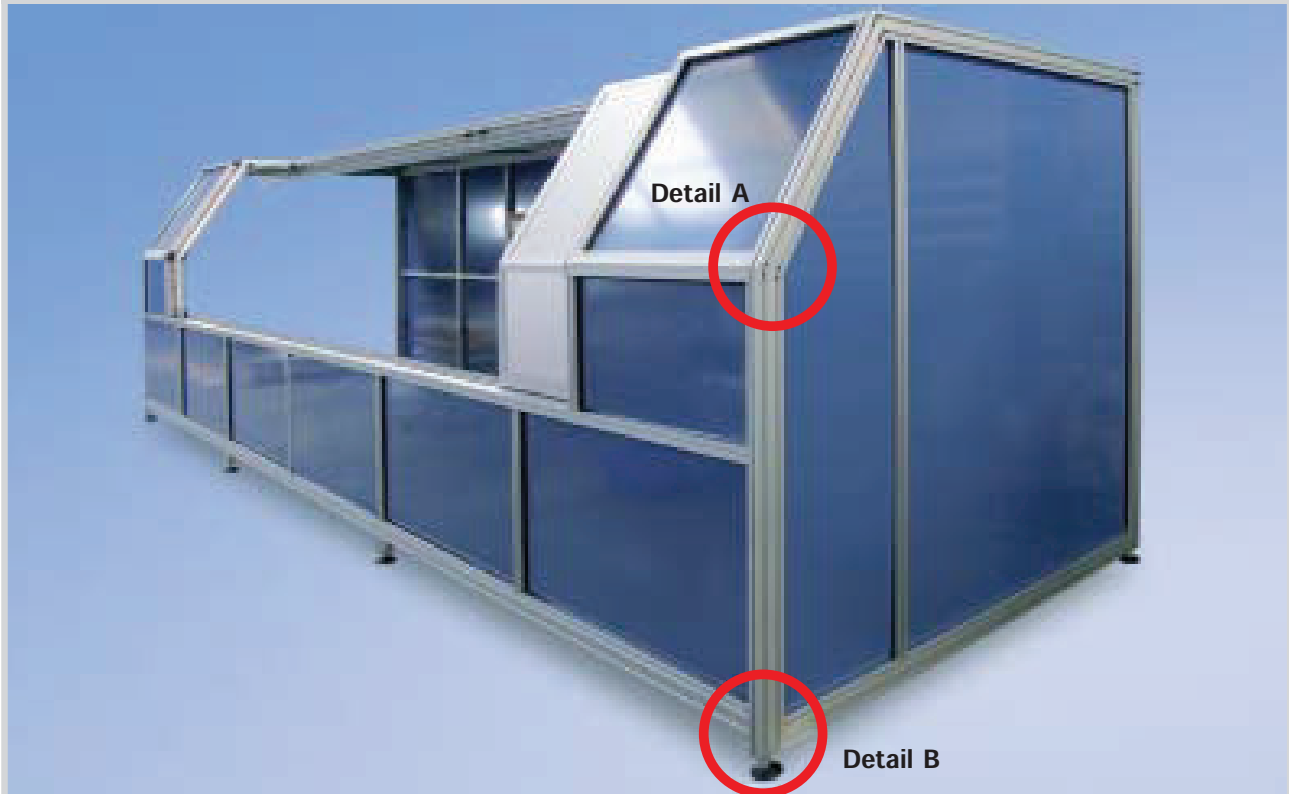

Detail A

| Page 111

Detail B

| Page 163

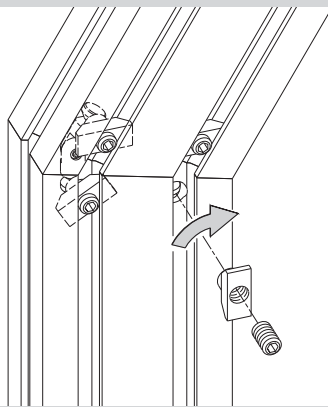

Swivel Tension Plug

B51.03.011

The swivel tension plug can be used to connect mitered series 40 profiles. All angles between +/- 90° can be accomplished. The connection requires a one-sided \varnothing 10 mm hole on the chamfered edge in both profiles at a distance of 15 mm from the middle of the cut edge.

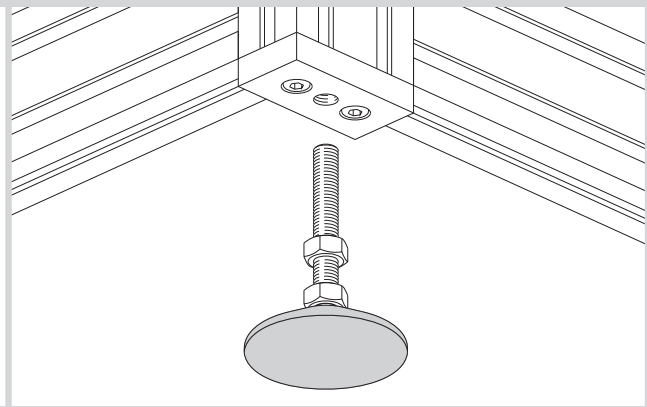

Leveling Pad KB M12

B67.02.001

The leveling pad is screwed into the pad plate matching the respective profile – here Pad Plate I M12 (50.02.0035). After adjusting the height, the pad is locked using the included hex nut. The leveling pad has an adjustment range of 75 mm and a loading capacity of 1,500 N. The ball and socket joint compensates for sloped surfaces.

Design examples

Assembly instructions

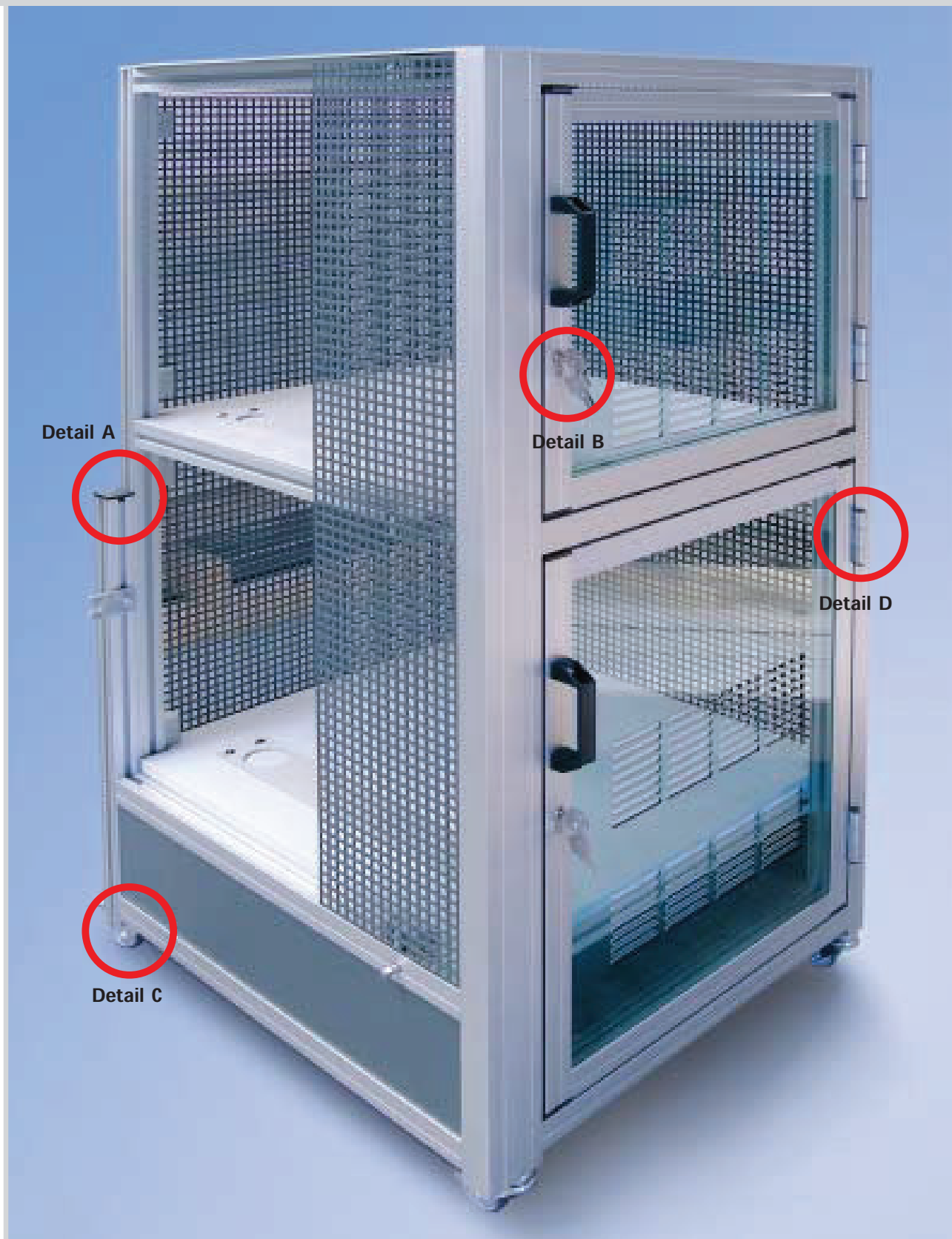

Detail A

| Page 132

Detail B

| Page 179

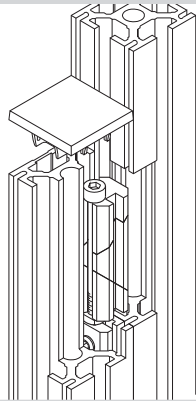

Parallel Tension Plug

B51.03.021

The parallel tension plug connects parallel profiles with no further rework required. To this end, the connector is inserted into both of the opposing profile slots, facing each other, and is securely tightened with an allen wrench.

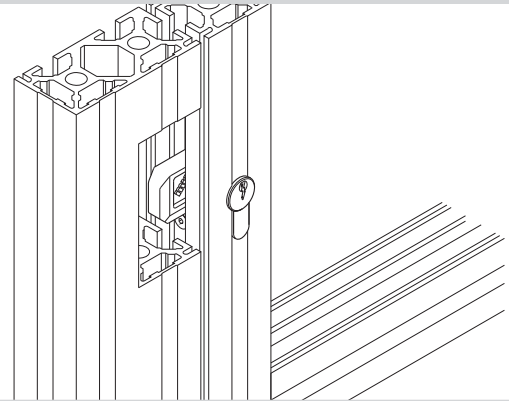

Cylinder Lock

B68.02.051

The lock is designed for installation in mk 2040.01 and mk 2040.40 profiles. This requires profile services 5401BC and 5440BC, whereby specifications must be made regarding both the total length of the profile and the distance from the bottom end of the profile up to the bottom edge of the lock. The profile cylinder is installed by pressing it through the profile opening in the keeper and is then secured by tightening the included hardware.

Detail C

| Page 166

Detail D

| Page 173

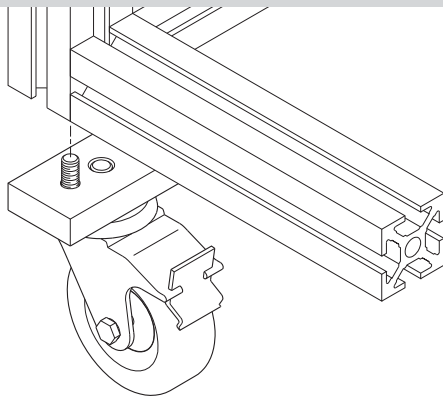

Fixed and Swivel Caster

K106001041 and K106000141

The casters are fastened to the appropriate pad plate using an M 10 hex head screw – here Pad Plate I M10 (50.02.0041). The casters have a load bearing capacity of 600 N. The swivel casters have a brake.

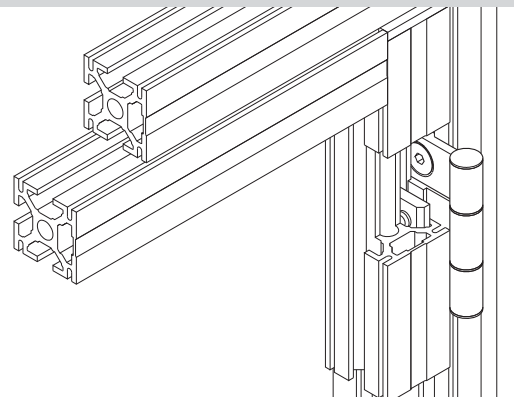

Hinge 40-1/40-7/40-1

B46.01.030

The hinge is mounted between two profiles using flat head socket head cap screws (FH-SHCS) and nuts. The appropriate mounting hardware is included with all hinges. The keys in the hinge arms ensure parallel orientation of the elements. If three hinge arms are used the door cannot be lifted and removed without tools.

Design examples

Assembly instructions

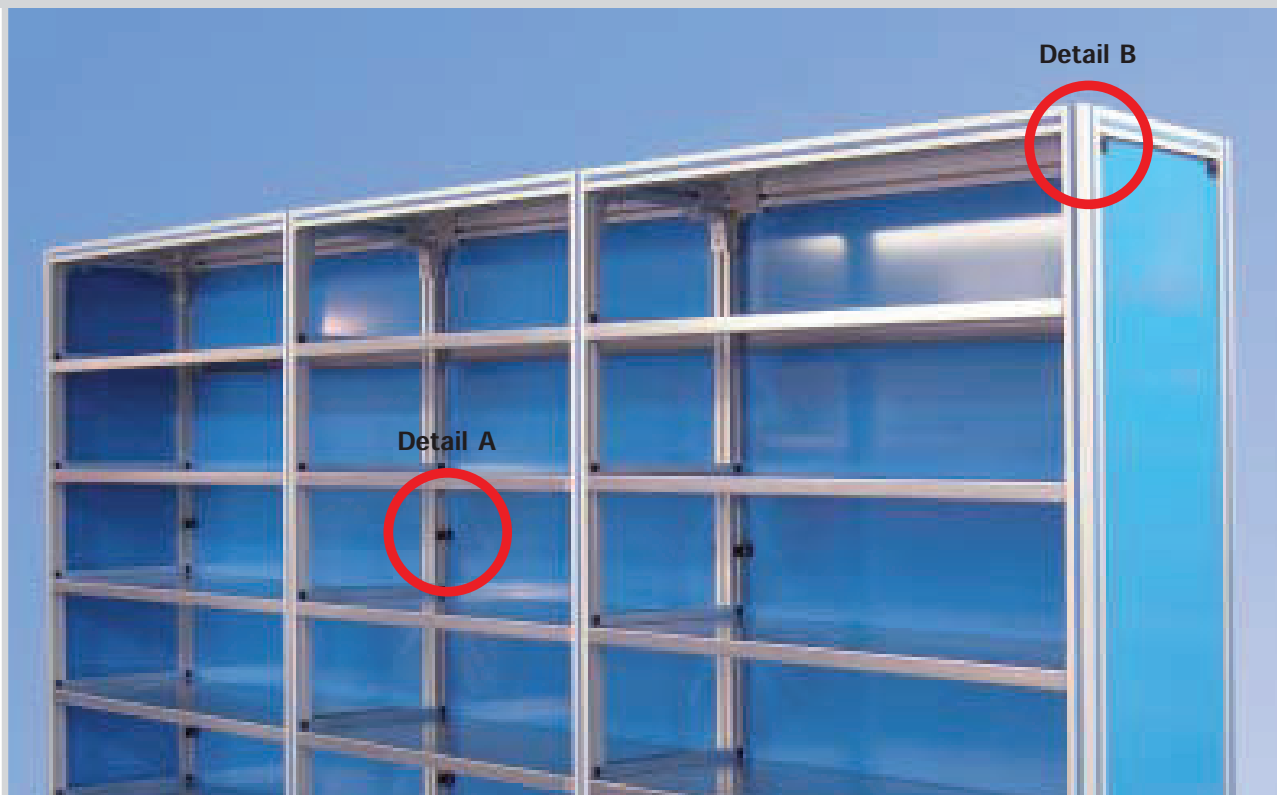

Detail A

| Page 186

Detail B

| Page 186

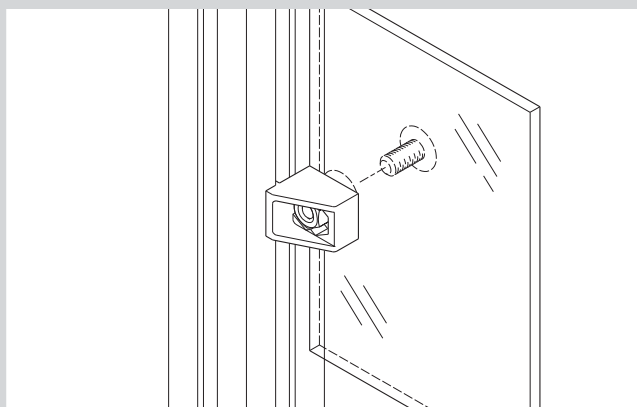

Paneling with Panel Block mk 2552

The 2552 plug is suitable for paneling from 2 to 6 mm thick. It is simply inserted into the series 40 T-slot and turned 45°. The paneling must include a 9 mm hole at each location. The paneling is then attached using M8 flanged button head screws and nuts. The paneling can be installed without gaps between it and the profile frame.

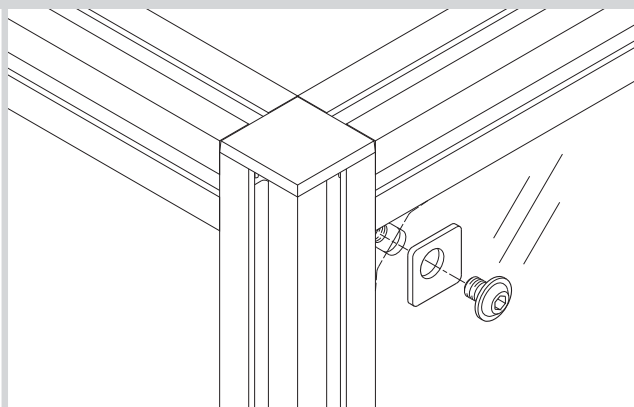

Paneling with Angles

This method is suitable for 1.5-2 mm thick metal sheets. The metal sheet edging provides the necessary stiffness up to a side length of 1200 mm. Panel Blocks mk 25552 are required for longer lengths. The angles must have an M8 thread placed in the side. The elongated hole can be covered with cover (07.01.0005); the metal sheets are screwed on using flanged button head screws (K112010003).

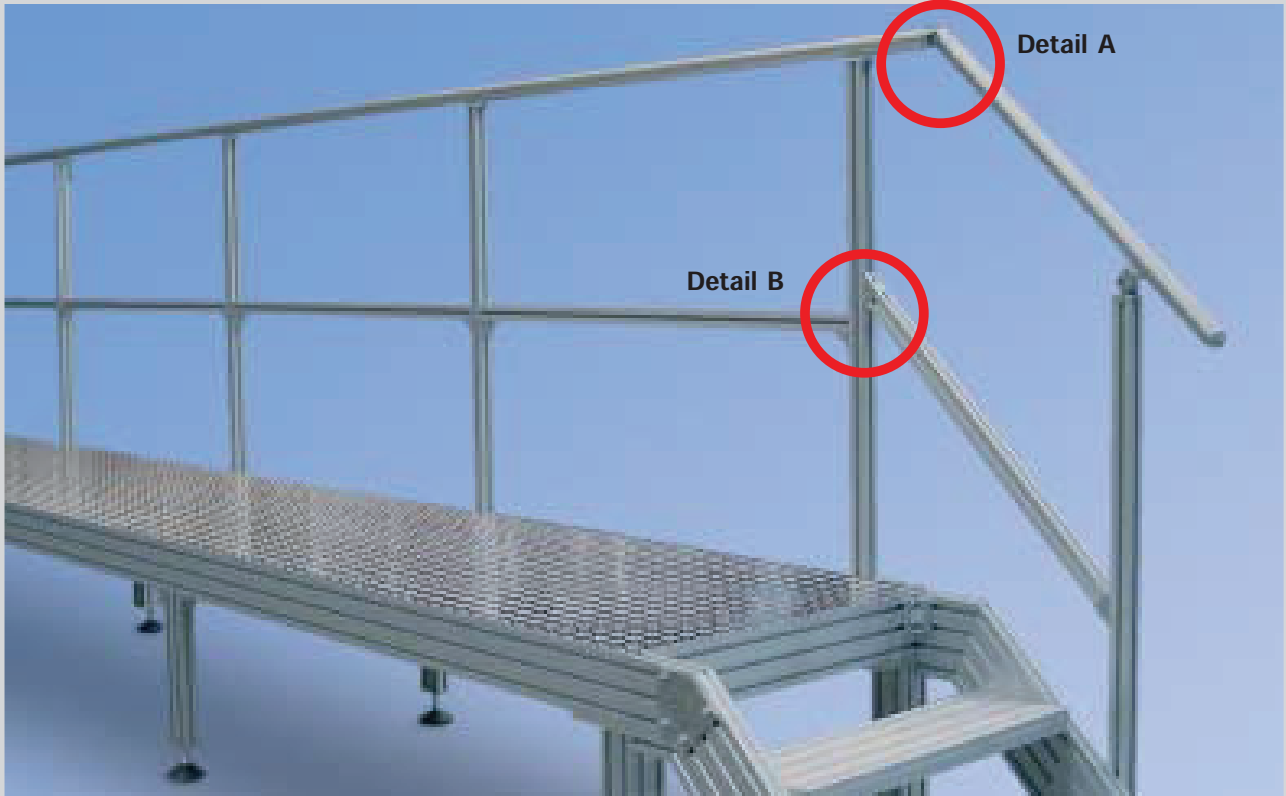

Detail A

Detail B

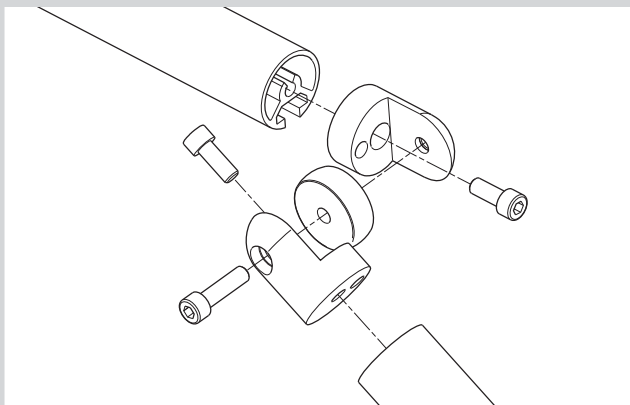

Joint 40/H2

B46.01.023

The joint connects two mk 2040.16 profiles at any angle required relative to each other. This is done by first screwing the two halves of the joint to the profiles using socket head cap screws and then mounting and locking the whole entire assembly with a using an additional socket head cap screw. All hardware shown is included.

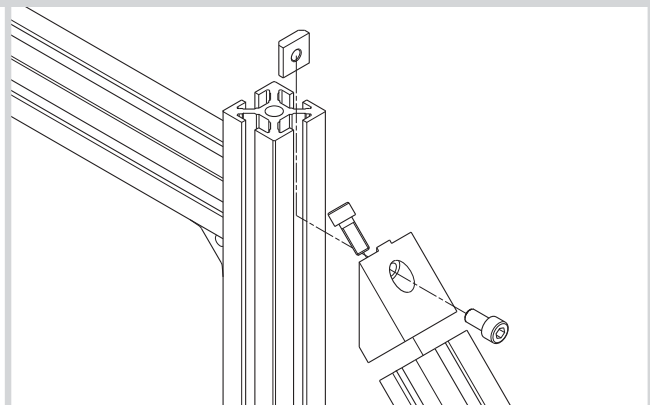

Corner Block 45°

79.01.0066

The corner block is used to connect two profiles at a 45° angle between them. The corner block is screwed into the end face of a 40x40 profile and is fixed to another profile by means of a screw-nut connection.

Design examples

Assembly instructions

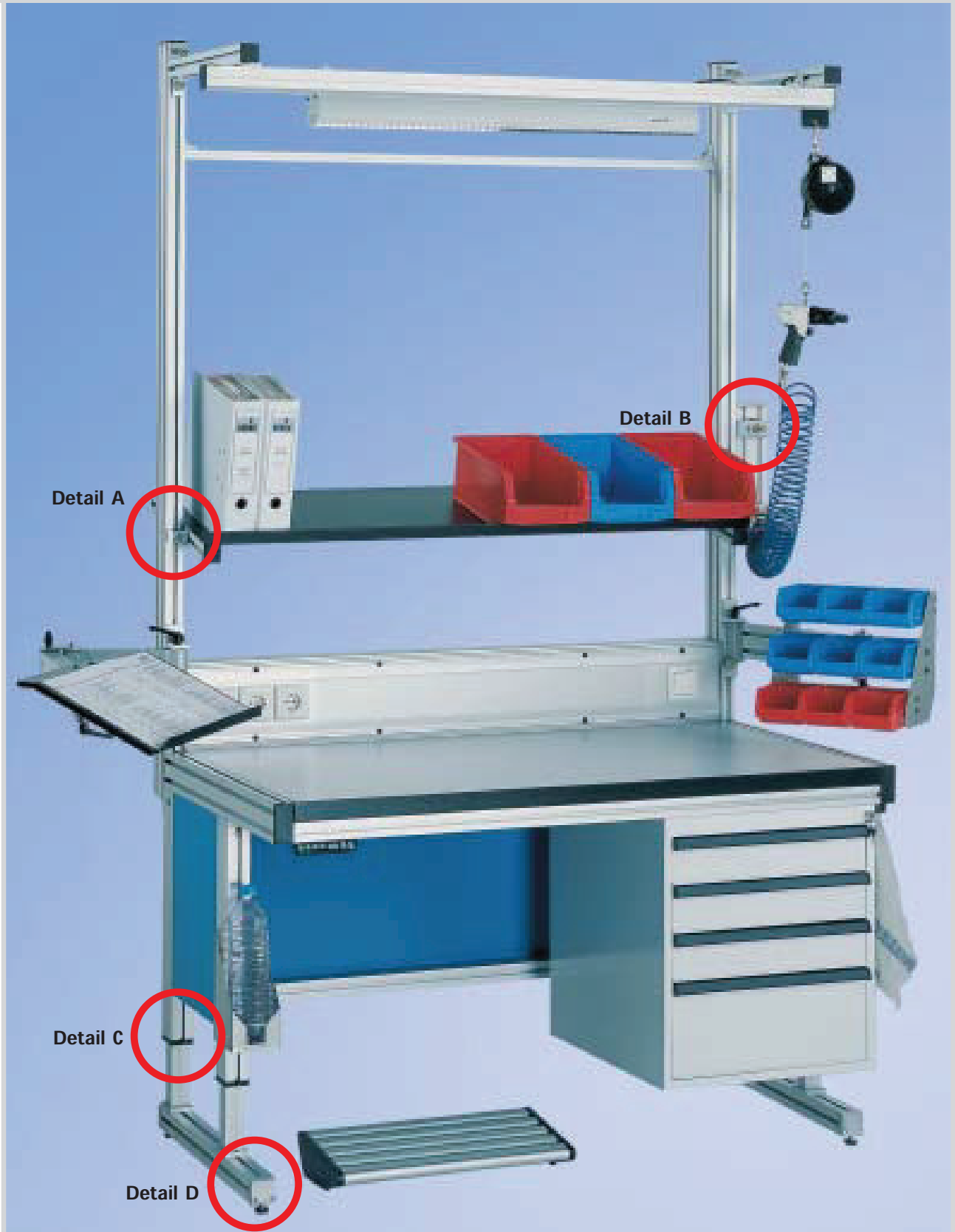

Detail A

| Page 90

Detail B

| Page 195

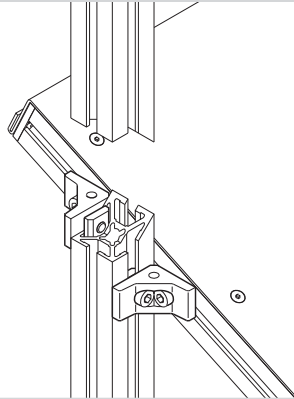

Angle E25 for fastening shelves

82.40.0701

The angles are mounted using M8x16 SHCS, \varnothing 8.4 ribbed washers and M8 nuts. The angles without keys are used when installing inclined shelves. This angle is easily achieved by offsetting the two angles along the support profile. All commonly used angles can also be purchased with the necessary mounting hardware as a set of components. The order number for the E25 angle with hardware is T82.40.0701.

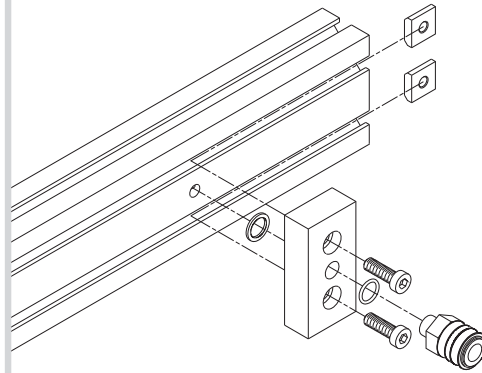

Pneumatic Component

53.00.0352

The interior of many of the series 40 profiles, i.e. mk 2040.02 or mk 2040.03 can be used to store compressed air. To access the compressed air, a \varnothing 8 mm hole must be made in the middle of the profile on the T-slot side and a distributor plate mounted at this location. It is sealed with an O-ring.

Detail C

| Page 47

Detail D

| Page 158

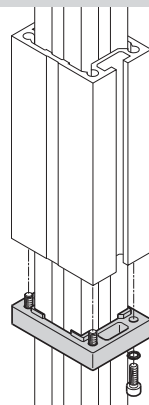

Telescoping Profile

mk 2040.74

A 40x40 mm profile can be inserted into this profile. The bottom cover is formed using the mk 2575 guide. To this end, threaded inserts must be placed into the mk 2040.74 profile.

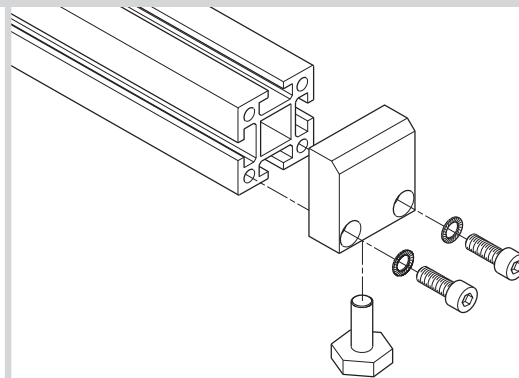

Pad Block

67.00.0002

The pad block is fastened by cutting an M8 thread in the lower holes of the mk 2000 profile. It is supported off the floor using the M10 leveling screw M10 (K110060003).

Design examples

Examples of Customer Applications



**Standard Guarding
(Post-Panel Method)**



**Example of a cross-connection
using consoles**



**Example of a connection for
platforms made using consoles**



Customer-specific workstations for integration of 19" racks and video monitors.
The basic structure is made from using series 25 profiles



Machine guarding with sliding doors that open in opposite directions



Customer-specific guard.
Paneling with PVC coated steel wire mesh fencing and fence clips

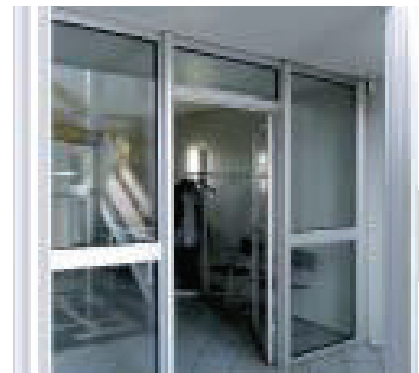

Design example of a room partition. Paneling with glass panes

Design examples

Examples of Customer Applications



mk platform with stairs made using mk 2040.68 profiles

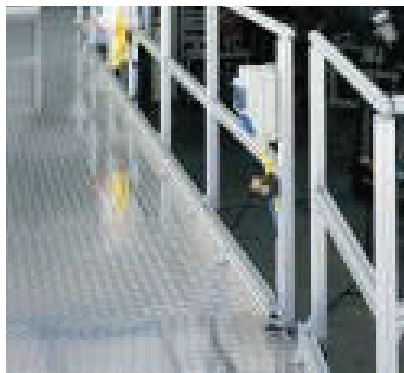

Standard guard rails with handrail, 40 mm diameter



Components such as the electrical supply can be integrated



Mobile gantry crane made from series 50 profiles, span 3000 mm, max frame load 1000 kg, max deflection < 2 mm

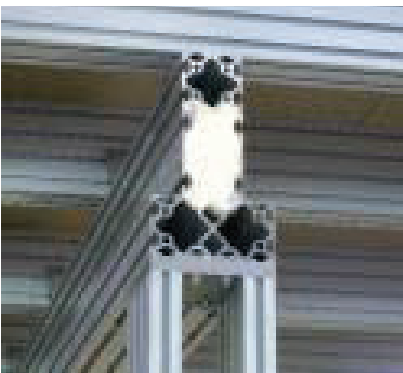

Warehouse platform using mk foamed profile as beams. The basic structure is made from series 40 profiles

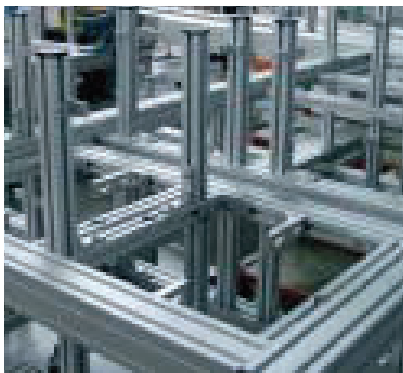

Frame structure for customer-specific conveyor system made using series 50 profiles



Cross-bracing using an mk connecting console

Design examples

Examples of Customer Applications

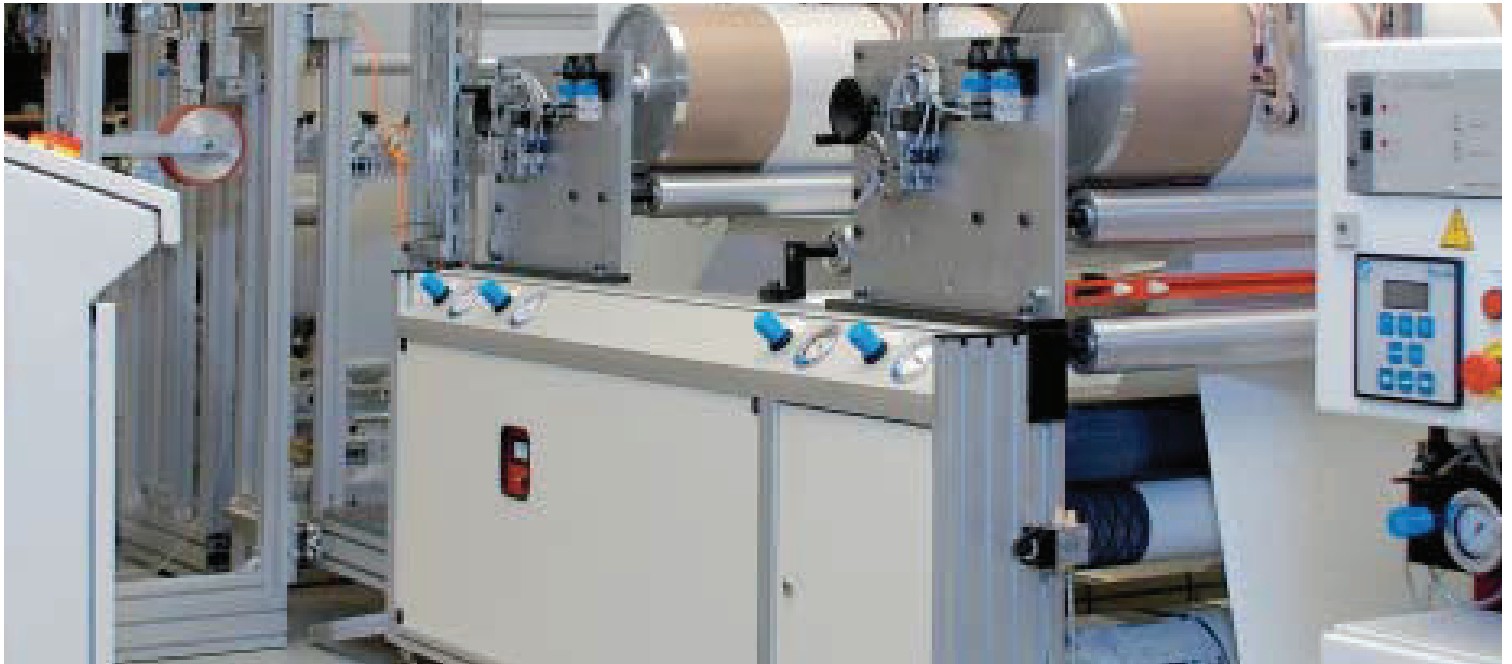

**Film storage with
pneumatic linear drive**



**Leveling pad for subsequent
anchoring to the floor**



Base frame for check-weigher made of series 40 profiles



Leveling pad and support bracket



Lattice

Network and Support

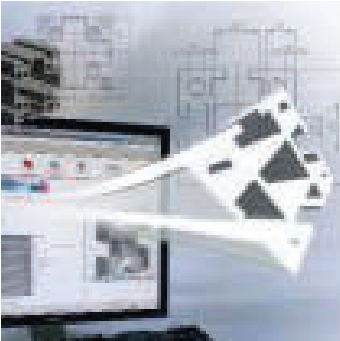

Contents Network and Support

| | | |
|---|-------------------------------|-----|
|  | mk CAD Parts Library | 280 |
|  | Internet | 281 |
|  | Product-Configurator | 281 |
|  | We're there where you need us | 282 |

mk CAD Parts Library



Online-Version



Under www.mk-group.com you find our CAD Parts Library.



There you will find CAD files via email.



Data formats for all common 2D and 3D CAD systems.



Individual components as well as configured assemblies.

CAD Parts Library

On request we can also send you our electronical product catalog on CD-ROM.



On our CD-ROM you will find the following data formats: DXF 2D, DWG 2D, STEP 3D and IGES 3D.



The CD-ROM also features RFQ and Ordering forms, as well as parts lists.



Further advantages include product search functions according to product name and part number as well as a shopping cart function.



Internet

Current information regarding mk products, trade shows, training, catalogs and other relevant news can be found on our home page.

- Check the status of your order at any time in using our new order tracking system.
- With your personal password you have direct access to all orders registered with our company.
- Order from our new online shop 24 hours a day.

Configurator for guarding

Design your guarding quickly and easily with the following advantages:

- Create guarding yourself without expensive engineering design
- Cost optimization thanks to the automatic selection of standard panels
- Very fast design, even of complex assemblies
- Software requires no additional CAD package
- Automatic creation of 3D guards on 2D floor plans
- Stand-alone configurator - no installation required
- Export 3D drawings in native file formats or exchange formats for further processing or inserting in your own CAD system
- Generation of parts lists for the guarding for placing an order with mk

Internet



3D-Product-Configurator

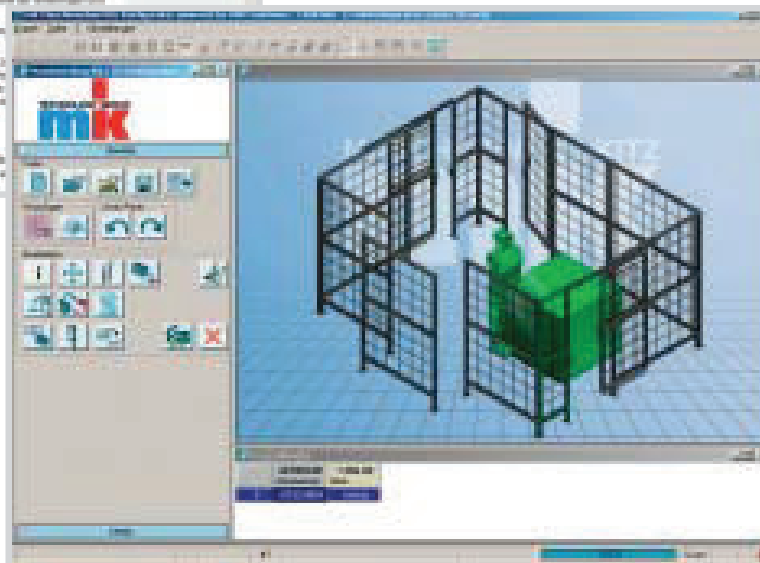

We're there
where you need us



Network International

mk Automation, Inc.
105 Highland Park Drive
Bloomfield, CT 06002
USA
Phone +1 860 769 5500
Fax +1 860 769 5505
www.mkprofiles.com
sales@mkprofiles.com

mk Profile Systems Ltd.
Unit 15, The Business Centre
Technology Drive, Beeston
Nottingham NG9 2ND
GREAT BRITAIN
Tel. +44 115 9221296
Fax +44 115 9228138
www.mkprofiles.co.uk
info@mkprofiles.co.uk

mk System 2000 AG
Solothurnstraße 55
3294 Büren an der Aare
SWITZERLAND
Phone +41 32 3512322
Fax +41 32 3514628
www.mk-system.ch
mk2000@mk-system.ch

mk Products b.v.
Windmolen 14a
7609 NN Almelo
NETHERLANDS
Phone +31 546 815065
Fax +31 546 827245
www.mkproducts.nl
info@mkproducts.nl

APA
Application des
Périphériques d'Automation
B.P. 445
6, rue d'Alsace
76504 Elbeuf Cedex
FRANCE
Phone +33 232 962660
Fax +33 235 877238
www.apafrance.com
apa@apabolvibrant.com

mk Kitz Hispania S.L.
Calle México nº2
50196 La Muela (Zaragoza)
SPAIN
Phone +34 976 149208
Fax +34 976 149209
www.mkhispania.es
info@mkhispania.es

Each hour of machine downtime for one of your customers costs you money and reputation. That's why we are always at your side as a partner in an emergency. mk's numerous sales, production

and service locations in Germany, Europe and USA will support you with the expertise and service you have come to expect from us. And you don't only profit from our widespread local

presence after the sale. Right from the design phase our motto is: The implementation of economic and forward looking planning pays off. So use our international network.

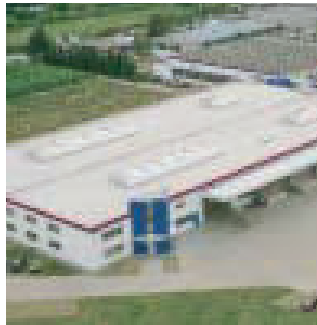

Germany



**Great Britain,
Ireland**



Switzerland



France



**Spain,
Portugal**



**Netherlands,
Belgium**



**USA, Canada
and Mexico**

Component Index

| | | | |
|--|----------|---|----------|
| Accessory Components for Guardrails | 218, 219 | Dimensions and Threads Series 40 | 36 |
| Adapter Profiles from series 25 to series 40 | 35 | Dimensions and Threads Series 50 | 54 |
| Adapter Profiles from series 40 to series 25 | 50 | Dimensions and Threads Series 60 | 60 |
| Adapter Profiles from series 40 to series 40 | 51 | Drill Fixtures | 226 |
| Adjustable Angles | 102, 103 | Drill Fixtures for Cleanroom Profiles | 228 |
| Adjustable Handle | 171 | Drill Fixtures for Pneumatic Components | 227 |
| Advantages Angles | 86 | Electric Components Sensor Brackets | 198 |
| Angle Braces | 131 | Electric Components Wireways | 199 |
| Angles Series 25 | 88, 89 | End Caps | 200-203 |
| Angles Series 40 | 90-93 | End Services | 74-80 |
| Angles Series 40 and 50 | 100 | Examples Angles | 87 |
| Angles Series 50 | 94-97 | Examples of Customer Applications | 272-277 |
| Angles Series 60 | 98, 99 | External locks | 178 |
| Ball Bases | 212, 213 | Face Plates | 112 |
| Ball latches | 177 | Fixed and Swivel Casters Type A | 166 |
| Base Plates Series 40 | 150 | Fixed and Swivel Casters Type B | 167 |
| Base Plates Series 50 | 151, 152 | Floor Mounting Brackets Series 40 | 148 |
| Base Plates Series 60 | 152 | Floor Mounting Plates Series 40 | 149 |
| Bumpers | 222 | Foamed Profiles | 68-71 |
| Carriage Rollers | 193, 194 | Glides and Bushings | 220, 221 |
| Carriage Wagons | 234, 235 | Grounding | 140 |
| Cast Bases | 153 | Handles | 170 |
| Cast Consoles | 104-106 | Handwheels | 169 |
| Clamps | 134, 135 | Hinges | 172-175 |
| Clamps and Offsets | 216 | Hinges for Panels | 176 |
| Cleanroom Profiles Series 40 | 43-44 | Hoists | 168 |
| Cleanroom Profiles Series 50 | 57 | How to use the Catalog | 22 |
| Closure and Seal Strips | 182, 183 | Information about Profile Technology | 24, 25 |
| Components for Sliding Doors | 181 | Internal Fasteners Series 25 | 108 |
| Conversion table | 259 | Internal Fasteners Series 40 | 108 |
| Corner Blocks Series 25 | 121, 122 | Internal Fasteners Series 40 light | 109 |
| Corner Blocks Series 40 | 123-126 | Internal Fasteners Series 40/1 | 109 |
| Corner Blocks Series 50 | 127, 128 | Internal Fasteners Series 50 | 110 |
| Cover and Adapter Profiles Series 60 | 63 | Internal locks | 179 |
| Curved Profiles | 72, 73 | Internet | 281 |
| Design examples | 262-271 | Introducing mk | 10-13 |
| Determining the Deflection Series 25 | 244, 245 | Leveling Pads | 163, 164 |
| Determining the Deflection Series 40 | 246, 247 | Mini-Rollers | 192 |
| Determining the Deflection Series 50 | 248, 249 | mk CAD Parts Library | 280 |
| Determining the Deflection Series 60 | 250, 251 | Nuts | 136-139 |
| Dimensions and Threads Series 35 | 30 | Our Business Fields | 14-21 |

| | | | |
|--|----------|--|----------|
| Pad Blocks and Plates | 158-162 | System 2000 Series 40 | 37-39 |
| Paneling | 184, 185 | System 2000 Series 50 | 55, 56 |
| Paneling Clamping profile for fencing | 188 | System 2000 Series 60 | 61, 62 |
| Paneling with Angles | 186 | Technical Datas | 252-258 |
| Paneling with Fence Clamp | 187 | Threads and Inserts | 81 |
| Paneling with Fence Clip System | 187 | Tools | 224, 225 |
| Paneling with Panel Blocks | 186 | Turntables | 232, 233 |
| Paneling with Panel Clamps | 186 | Using the mk profile technology system | 26, 27 |
| Paneling with Windows | 189-191 | We're there where you need us | 282, 283 |
| Parallel Actuator Module PHM-A 20 | 236 | Wear Strips | 204-206 |
| Parallel Actuator Module PHM-I 20 | 237 | Wear Strips for Guides and Slides | 207 |
| Parallel Connectors | 132 | | |
| Pedestal Bases | 154-157 | | |
| Plates Heavy duty version | 116-120 | | |
| Plates Light version | 113-115 | | |
| Pneumatic Components | 195-197 | | |
| Product-Configurator | 281 | | |
| Profile Series 40 Cover profiles | 52, 53 | | |
| Profile Wedges | 129, 130 | | |
| Profiles for Door Frames | 65 | | |
| Profiles for Floors and Steps | 66 | | |
| Profiles for Partitions and Workstations | 48 | | |
| Profiles for Sheets and Paneling | 64 | | |
| Profiles for Sliding Doors | 49 | | |
| Profiles for Telescoping Series 40 | 46, 47 | | |
| Profiles for Telescoping Series 50 | 58 | | |
| Quick-Reference | 4-9 | | |
| Rods | 217 | | |
| Screws | 141 | | |
| Screws, Nuts and Spring Washers | 142 | | |
| Selection criteria for Assembly Components | 85 | | |
| Series 25 with closed T-slots | 32, 33 | | |
| Series 40 with closed T-slots | 40, 41 | | |
| Slide bolt | 180 | | |
| Standards, Norms and Calculations | 240-242 | | |
| Support Bracket | 165 | | |
| Swivel Clamps | 214, 215 | | |
| Swivel Joints Series 40 | 208, 209 | | |
| Swivel Joints Series 50 | 210, 211 | | |
| Swivel Tension Plug | 111 | | |
| System 2000 Series 25 | 31 | | |

Index by Ident-No.

Profile Index

| | | | | | |
|--------------|--------------------|--------|--------------|--------------------|-----|
| 25.01.* | Profile mk 2025.01 | 31 | 52.06.* | Profile mk 2206 | 64 |
| 25.02.* | Profile mk 2025.02 | 31 | 52.07.* | Profile mk 2207 | 64 |
| 25.03.* | Profile mk 2025.03 | 31 | 52.10.* | Profile mk 2210 | 64 |
| 25.04.* | Profile mk 2025.04 | 31 | 52.11.* | Profile mk 2211 | 64 |
| 25.05.* | Profile mk 2025.05 | 31 | 52.14.* | Profile mk 2214 | 64 |
| 25.16.* | Profile mk 2025.16 | 33 | 52.15.* | Profile mk 2215 | 64 |
| 25.17.* | Profile mk 2025.17 | 33 | 52.20.* | Profile mk 2220 | 189 |
| 25.18.* | Profile mk 2025.18 | 33 | 52.40.* | Profile mk 2240 | 63 |
| 25.19.* | Profile mk 2025.19 | 33 | 52.41.* | Profile mk 2241 | 63 |
| 25.20.* | Profile mk 2025.20 | 34 | 52.44.* | Profile mk 2244 | 49 |
| 25.21.* | Profile mk 2025.21 | 34 | 52.45.* | Profile mk 2245 | 49 |
| 25.22.* | Profile mk 2025.22 | 34 | 54.01.* | Profile mk 2040.01 | 37 |
| 25.25.* | Profile mk 2025.25 | 33 | 54.02.* | Profile mk 2040.02 | 38 |
| 25.31.* | Profile mk 2025.31 | 32 | 54.03.* | Profile mk 2040.03 | 38 |
| 25.32.* | Profile mk 2025.32 | 33 | 54.04.* | Profile mk 2040.04 | 41 |
| 25.35.* | Profile mk 2025.35 | 32 | 54.05.* | Profile mk 2040.05 | 38 |
| 25.36.* | Profile mk 2025.36 | 33 | 54.06.* | Profile mk 2040.06 | 38 |
| 25.37.* | Profile mk 2025.37 | 33 | 54.07.* | Profile mk 2040.07 | 39 |
| 25.38.* | Profile mk 2025.38 | 32 | 54.08.* | Profile mk 2040.08 | 39 |
| 25.39.* | Profile mk 2025.39 | 33 | 54.09.* | Profile mk 2040.09 | 39 |
| 25.41.* | Profile mk 2025.41 | 35, 50 | 54.10.* | Profile mk 2040.10 | 39 |
| 25.42.* | Profile mk 2025.42 | 35, 50 | 54.11.* | Profile mk 2040.11 | 40 |
| 25.43.* | Profile mk 2025.43 | 35, 50 | 54.12.* | Profile mk 2040.12 | 41 |
| 25.44.* | Profile mk 2025.44 | 35, 50 | 54.13.* | Profile mk 2040.13 | 41 |
| 51.00.* | Profile mk 2000 | 55 | 54.14.* | Profile mk 2040.14 | 40 |
| 51.01.* | Profile mk 2001 | 55 | 54.15.* | Profile mk 2040.15 | 40 |
| 51.02.* | Profile mk 2002 | 55 | 54.16.* | Profile mk 2040.16 | 42 |
| 51.03.* | Profile mk 2003 | 56 | 54.17.* | Profile mk 2040.17 | 41 |
| 51.04.* | Profile mk 2004 | 55 | 54.18.* | Profile mk 2040.18 | 41 |
| 51.05.* | Profile mk 2005 | 56 | 54.19.* | Profile mk 2040.19 | 41 |
| 51.06.* | Profile mk 2006 | 56 | 54.20.* | Profile mk 2040.20 | 41 |
| 51.08.* | Profile mk 2008 | 56 | 54.21.* | Profile mk 2040.21 | 40 |
| 51.11.* | Profile mk 2011 | 56 | 54.22.* | Profile mk 2040.22 | 41 |
| 51.17.* | Profile mk 2017 | 57 | 54.23.* | Profile mk 2040.23 | 48 |
| 51.30.* | Profile mk 2030 | 55 | 54.24.* | Profile mk 2040.24 | 41 |
| 51.31.* | Profile mk 2031 | 58 | 54.25.* | Profile mk 2040.25 | 65 |
| 51.33.* | Profile mk 2033 | 58 | 54.30.* | Profile mk 2040.30 | 48 |
| 51.50.* | Profile mk 2050 | 199 | 54.31.* | Profile mk 2040.31 | 37 |
| 51.51.* | Profile mk 2051 | 199 | 54.32.* | Profile mk 2040.32 | 52 |
| 51.72.* | Profile mk 2072 | 56 | 54.34.* | Profile mk 2040.34 | 48 |
| 52.03.* | Profile mk 2203 | 64 | 54.37.* | Profile mk 2040.37 | 47 |

Profile Index

| | | |
|---------------|---------------------|-----|
| 54.38.* | Profile mk 2040.38 | 47 |
| 54.39.* | Profile mk 2040.39 | 47 |
| 54.40.* | Profile mk 2040.40 | 37 |
| 54.41.* | Profile mk 2040.41 | 38 |
| 54.42.* | Profile mk 2040.42 | 52 |
| 54.43.* | Profile mk 2040.43 | 52 |
| 54.44.* | Profile mk 2040.44 | 52 |
| 54.45.* | Profile mk 2040.45 | 38 |
| 54.46.* | Profile mk 2040.46 | 41 |
| 54.50.* | Profile mk 2040.50 | 199 |
| 54.51.* | Profile mk 2040.51 | 199 |
| 54.52.* | Profile mk 2040.52 | 37 |
| 54.59.* | Profile mk 2040.59 | 190 |
| 54.60.* | Profile mk 2040.60 | 188 |
| 54.68.* | Profile mk 2040.68 | 66 |
| 54.69.* | Profile mk 2040.69 | 66 |
| 54.73.* | Profile mk 2040.73 | 38 |
| 54.74.* | Profile mk 2040.74 | 47 |
| 54.75.* | Profile mk 2040.75 | 47 |
| 54.80.* | Profile mk 2040.80 | 51 |
| 54.81.* | Profile mk 2040.81 | 190 |
| 54.82.* | Profile mk 2040.82 | 190 |
| 54.85.* | Profile mk 2040.85 | 53 |
| 54.86.* | Profile mk 2040.86 | 51 |
| 54.88.* | Profile mk 2040.88 | 65 |
| 54.92.* | Profile mk 2040.92 | 42 |
| 54.93.* | Profile mk 2040.93 | 42 |
| 54.94.* | Profile mk 2040.94 | 43 |
| 54.95.* | Profile mk 2040.95 | 43 |
| 54.100.* | Profile mk 2040.100 | 43 |
| 54.101.* | Profile mk 2040.101 | 43 |
| 60.01.* | Profile mk 2060.01 | 61 |
| 60.02.* | Profile mk 2060.02 | 61 |
| 60.03.* | Profile mk 2060.03 | 61 |
| 60.04.* | Profile mk 2060.04 | 62 |
| 60.05.* | Profile mk 2060.05 | 62 |
| 60.07.* | Profile mk 2060.07 | 62 |

Index by Ident-No.

Article Index

| | | | | | |
|-----------------|-------------------------|-----|------------|------------------------------|-----|
| 0100AA* | Shaft ø 16 | 220 | 22.27.2000 | Wear Strip mk 1027 | 207 |
| 0100AB* | Shaft ø 16 | 220 | 22.30.2000 | Wear Strip mk 1030 | 206 |
| 0100AE* | Shaft ø 12 | 220 | 22.31.2000 | Wear Strip mk 1031 | 206 |
| 0100AF* | Shaft ø 12 | 220 | 22.70.2000 | Wear Strip mk 1070 | 205 |
| 0101AA* | Shaft | 220 | 22.71.2000 | Wear Strip mk 1071 | 205 |
| 07.13.0002 | Spring Clip for Nut 18 | 139 | 22.72.2000 | Wear Strip mk 1072 | 205 |
| 07.13.0003 | Spring Clip for Nut M56 | 139 | 22.90.0035 | Door Stop for Swing Doors | 177 |
| 07.28.0000.0000 | Steel Cut | 185 | 22.90.2000 | Wear Strip mk 1090 | 206 |
| 07.29.0000.0000 | Stainless Steel Cut | 185 | 22.91.2000 | Wear Strip mk 1091 | 206 |
| 07.30.0000.0000 | Aluminum Cut | 185 | 22.92.0035 | Door Stop for Swing Doors | 177 |
| 07.33.0000.0000 | Aluminum Cut | 185 | 24.00.0000 | Fencing Alu Cut | 184 |
| 14.00.0004 | Corner Clip | 188 | 24.02.0000 | Fencing Steel Cut | 184 |
| 14.04.0007 | Spacer | 212 | 24.05.0000 | FencingCut | 185 |
| 16.00.0000 | Sensor Bracket A ø 13 | 198 | 25.50.0500 | Nut M5 | 136 |
| 16.00.0001 | Sensor Bracket A ø 19 | 198 | 25.50.0501 | Slot Nut M5 | 138 |
| 16.00.0006 | Sensor Bracket B ø 13 | 198 | 25.50.0504 | Nut 2/25 M5 | 136 |
| 16.00.0007 | Sensor Bracket B ø 19 | 198 | 25.50.0505 | Nut 2/25 PE M5 | 140 |
| 16.00.0016 | Sensor Bracket D ø 9 | 198 | 25.50.0508 | Nut PE M5 | 140 |
| 16.00.0017 | Sensor Bracket D ø 13 | 198 | 25.50.0512 | Nut M6 | 136 |
| 16.00.0018 | Sensor Bracket D ø 19 | 198 | 25.50.0513 | Nut 2/25 M6 | 136 |
| 16.00.0026 | Sensor Bracket E ø 9 | 198 | 25.50.0518 | Nut PE M6 | 140 |
| 16.00.0027 | Sensor Bracket E ø 13 | 198 | 25.50.0540 | Nut M4 | 136 |
| 16.00.0028 | Sensor Bracket E ø 19 | 198 | 25.50.0541 | Slot Nut M4 | 138 |
| 16.05.0011 | Sensor Bracket R1/4'' | 198 | 25.50.1000 | Angle 15 | 88 |
| 19.00.0005 | Guide for Sliding Door | 181 | 25.50.1001 | Angle 40 | 88 |
| 19.02.0022 | Guide | 47 | 25.50.1010 | Angle S15 | 89 |
| 21.01.2000 | Wear Strip mk 1040.01 | 204 | 25.50.1012 | Angle S40 | 89 |
| 22.01.2000 | Wear Strip mk 1001 | 205 | 25.50.1020 | Angle A25/15/2 | 88 |
| 21.02.2000 | Wear Strip mk 1040.02 | 205 | 25.50.1021 | Angle A25/40/2 | 88 |
| 21.03.2000 | Wear Strip mk 1040.03 | 205 | 25.50.3000 | Straight Plate 01 | 113 |
| 21.04.2000 | Wear Strip mk 1040.04 | 205 | 25.50.3001 | Straight Plate 02 | 113 |
| 21.05.2000 | Wear Strip mk 1040.05 | 205 | 25.50.3002 | Angle Plate 01 | 113 |
| 21.62.2000 | Wear Strip mk 1060.62 | 205 | 25.50.3006 | T-Plate 01 | 113 |
| 21.63.2000 | Wear Strip mk 1060.63 | 205 | 25.50.3300 | Corner Block 25 | 121 |
| 21.64.2000 | Wear Strip mk 1060.64 | 205 | 25.50.3301 | Corner Block 26 | 121 |
| 22.00.2000 | Wear Strip mk 1000 | 204 | 25.50.3330 | Parallel Connector Series 25 | 132 |
| 22.08.2000 | Wear Strip mk 1008 | 205 | 25.50.7000 | Clamp 25/0 | 134 |
| 22.09.2000 | Wear Strip mk 1009 | 206 | 25.50.7001 | Clamp 25/1 | 134 |
| 22.17.2000 | Wear Strip mk 1017 | 205 | 25.50.7002 | Clamp 25/2 | 134 |
| 22.21.2000 | Wear Strip mk 1021 | 207 | 25.50.8000 | End Cap | 200 |
| 22.26.2000 | Wear Strip mk 1026 | 207 | 25.50.8001 | End Cap | 200 |

Article Index

| | | | | | |
|------------|-----------------------|-----|------------|--------------|-----|
| 25.50.8002 | End Cap | 201 | 34.01.0001 | Nut 1 M8 | 136 |
| 25.50.8003 | End Cap | 201 | 34.01.0002 | Nut 2/25 M8 | 136 |
| 25.50.8004 | End Cap | 200 | 34.01.0003 | Nut 2/50 M8 | 136 |
| 25.50.8005 | End Cap | 200 | 34.01.0004 | Nut 3/25 M8 | 137 |
| 25.71.2000 | Wear Strip mk 1025.71 | 204 | 34.01.0005 | Nut 2/75 M8 | 137 |
| 25.72.2000 | Wear Strip mk 1025.72 | 204 | 34.01.0006 | Nut 3/50 M8 | 137 |
| 25.73.2000 | Wear Strip mk 1025.73 | 204 | 34.01.0007 | Nut 4/50 M8 | 137 |
| 26.00.0006 | Support Bracket 1 | 165 | 34.01.0011 | Nut 2/35 M8 | 136 |
| 26.00.0012 | Support Bracket 2 | 165 | 34.01.0018 | Nut 1 PE M8 | 140 |
| 26.00.0060 | Support Bracket 60/1 | 165 | 34.01.0019 | Nut 2/40 M8 | 136 |
| 30.00.0001 | Clamp | 216 | 34.01.0022 | Nut 3/40 M8 | 137 |
| 30.00.0002 | Clamp | 216 | 34.01.0024 | Nut 1 M8 | 136 |
| 30.00.0013 | Clamp | 216 | 34.02.0008 | Nut 1 M6 | 136 |
| 30.00.0017 | Clamp | 216 | 34.02.0010 | Nut 2/25 M6 | 136 |
| 30.00.0023 | Clamp | 215 | 34.02.0012 | Nut 1 M6 | 136 |
| 30.00.0024 | Clamp | 215 | 34.02.0018 | Nut 1 PE M6 | 140 |
| 30.00.0027 | Clamp 1/40 | 135 | 34.03.0001 | Slot Nut M8 | 138 |
| 30.00.0029 | Clamp 2/40 | 135 | 34.03.0002 | Slot Nut M8 | 138 |
| 30.00.0033 | Clamp 5/30 | 134 | 34.04.0001 | Slot Nut M6 | 138 |
| 30.00.0034 | Clamp 5/40 | 135 | 34.04.0002 | Slot Nut M5 | 138 |
| 30.00.0035 | Clamp 6/30 | 135 | 34.04.0003 | Slot Nut M6 | 138 |
| 30.00.0036 | Clamp 6/40 | 135 | 34.06.0002 | T-Nut M8 | 138 |
| 30.00.0037 | Clamp 7/80 | 135 | 34.07.0002 | T-Nut M6 | 138 |
| 30.00.0038 | Clamp short | 216 | 34.07.0003 | T-Nut M5 | 138 |
| 30.00.0040 | Clamp C1 | 212 | 34.07.0004 | T-Nut M4 | 138 |
| 30.00.0047 | Clamp | 216 | 34.08.0001 | Nut 1 M4 | 136 |
| 30.00.0048 | Clamp 40/25 | 134 | 34.08.0004 | Nut 1 M4 | 136 |
| 30.00.0056 | Clamp F1 | 212 | 34.09.0001 | Nut S1 | 138 |
| 30.00.0117 | Fence Clamp | 187 | 34.09.0002 | Nut S2/50 | 138 |
| 30.01.0007 | Ball | 212 | 34.09.0003 | Offset 25 | 216 |
| 31.00.0001 | Console 1 | 104 | 34.09.0004 | Offset 50 | 216 |
| 31.00.0002 | Console 2 | 104 | 34.09.0006 | Nut S2/100 | 138 |
| 31.00.0004 | Console 4 | 104 | 34.09.0007 | Nut S2/40 | 138 |
| 31.00.0005 | Console 5 | 105 | 34.12.0001 | Nut 1 M5 | 136 |
| 31.00.0007 | Console 7 | 105 | 34.12.0004 | Nut 1 M5 | 136 |
| 31.00.0014 | Console 14 | 105 | 34.14.0006 | Clip M4 | 138 |
| 31.00.0015 | Console 15 | 105 | 34.14.0007 | Clip M5 | 138 |
| 31.00.0016 | Console 16 | 105 | 34.14.0008 | Clip M6 | 138 |
| 31.40.0016 | Console 16/40 | 104 | 34.60.0101 | Nut 1M8 | 137 |
| 31.60.0001 | Console 60/1 | 106 | 34.60.0201 | Nut 1M10 | 137 |
| 31.60.0007 | Console 60/7 | 106 | 34.60.0203 | Nut 2/60 M10 | 137 |

Index by Ident-No.

Article Index

| | | | | | |
|------------|-------------------------|-----|------------|--------------------|-----|
| 34.60.0205 | Nut 3/60 M10 | 137 | 50.02.0050 | Pad Plate J M20 | 160 |
| 34.60.0301 | Nut 1M12 | 137 | 50.02.0067 | Pad Plate J M12 | 160 |
| 34.60.0303 | Nut 2/60 M12 | 137 | 50.02.0068 | Pad Plate M10 | 160 |
| 34.60.0305 | Nut 3/60 M12 | 137 | 50.02.0076 | Pedestal Base 8 | 155 |
| 34.60.0321 | Nut 1 M12 | 137 | 50.02.0077 | Pedestal Base 9 | 155 |
| 34.60.1101 | Slot Nut M8 | 138 | 50.02.0088 | Pedestal Base 6 | 155 |
| 34.60.1201 | Slot Nut M10 | 138 | 50.02.0089 | Pedestal Base 7 | 155 |
| 34.60.1301 | Slot Nut M12 | 138 | 50.02.0091 | Pad Plate R1 | 167 |
| 34.60.2001 | Nut 1 AIM6 | 137 | 50.02.0093 | Pad Plate R3 | 166 |
| 34.60.2101 | Nut 1 AIM8 | 137 | 50.02.0094 | Pad Plate R4 | 167 |
| 35.00.0006 | Bushing ø 16 | 220 | 50.02.6004 | Pad Plate 60/4 M16 | 162 |
| 35.00.0007 | Bushing ø 12 | 220 | 50.02.6005 | Pad Plate 60/5 M20 | 162 |
| 35.00.0008 | Bushing | 220 | 50.02.6008 | Pad Plate 60/8 M16 | 162 |
| 3855BF0200 | Connecting Profile 3855 | 116 | 50.02.6009 | Pad Plate 60/9 M20 | 162 |
| 3856BD0200 | Connecting Profile 3856 | 117 | 50.03.0001 | Base Plate 1 | 151 |
| 3860BD0200 | Connecting Profile 3860 | 118 | 50.03.0002 | Base Plate 2 | 151 |
| 3861BD0200 | Connecting Profile 3861 | 118 | 50.03.0003 | Base Plate 4 | 151 |
| 50.01.0014 | Pedestal Base | 213 | 50.03.0004 | Base Plate 4a | 151 |
| 50.01.0016 | Pedestal Base | 213 | 50.03.0005 | Base Plate 5 | 152 |
| 50.01.0020 | Pedestal Base | 213 | 50.03.0006 | Base Plate 6 | 152 |
| 50.01.0021 | Pedestal Base | 213 | 50.03.0007 | Base Plate 7 | 152 |
| 50.02.0001 | Pad Plate C M16 | 161 | 50.03.0008 | Base Plate 8 | 152 |
| 50.02.0002 | Pad Plate C M20 | 161 | 50.03.0009 | Base Plate 40/1 | 150 |
| 50.02.0003 | Pad Plate B M16 | 161 | 50.03.0010 | Base Plate 40/2 | 150 |
| 50.02.0004 | Pad Plate B M20 | 161 | 50.03.0011 | Base Plate 40/3 | 150 |
| 50.02.0007 | Pad Plate G M16 | 159 | 50.03.0012 | Base Plate 40/4 | 150 |
| 50.02.0008 | Pad Plate G M20 | 159 | 50.03.0025 | Plate 40/17 | 149 |
| 50.02.0010 | Pad Plate D M12 | 159 | 50.03.0026 | Plate 40/18 | 149 |
| 50.02.0011 | Pad Plate D M16 | 159 | 50.03.0028 | Plate 40/20 | 149 |
| 50.02.0018 | Pad Plate F M16 | 159 | 50.03.0033 | Wall attachment | 219 |
| 50.02.0023 | Pedestal Base 1 | 157 | 50.03.0034 | Wall attachment | 219 |
| 50.02.0026 | Pedestal Base 2 | 157 | 50.03.6002 | Base Plate 60/2 | 152 |
| 50.02.0028 | Pedestal Base 4 | 157 | 50.03.6008 | Base Plate 60/8 | 152 |
| 50.02.0029 | Pedestal Base 5 | 157 | 50.05.0010 | Plate 10 | 119 |
| 50.02.0030 | Pad Plate I M16 | 160 | 50.05.0011 | Plate 11 | 119 |
| 50.02.0032 | Pad Plate J M16 | 160 | 50.05.0012 | Plate 12 | 119 |
| 50.02.0035 | Pad Plate I M12 | 160 | 50.05.0013 | Plate 13 | 119 |
| 50.02.0040 | Pad Plate K M16 | 160 | 50.05.0016 | Plate 16 | 118 |
| 50.02.0041 | Pad Plate I M10 | 160 | 50.05.0017 | Plate 17 | 118 |
| 50.02.0042 | Pad Plate J M10 | 160 | 50.05.0018 | Plate 18 | 119 |
| 50.02.0043 | Pad Plate K M10 | 160 | 50.05.0036 | Cylinder Plate | 221 |

Article Index

| | | | | | |
|------------|-------------------|-----|---------------|-------------------------|-----|
| 50.05.0045 | Angle Plate 03 | 115 | 53.00.0101 | End Plate B | 196 |
| 50.05.0046 | T-Plate 03 | 115 | 53.00.0200 | Supply Plate A | 196 |
| 50.05.0047 | Straight Plate 07 | 114 | 53.00.0201 | Supply Plate B | 196 |
| 50.05.0051 | Angle Plate 13 | 115 | 53.00.0202 | Supply Plate C | 196 |
| 50.05.0052 | Straight Plate 03 | 114 | 53.00.0210 | Supply Plate A | 196 |
| 50.05.0053 | Straight Plate 05 | 114 | 53.00.0211 | Supply Plate B | 196 |
| 50.05.0060 | Plate 40/2 | 116 | 53.00.0300 | Distributor Plate A18 | 196 |
| 50.05.0061 | Plate 40/3 | 116 | 53.00.0301 | Distributor Plate A28 | 196 |
| 50.05.0062 | Plate 40/4 | 117 | 53.00.0303 | Distributor Plate A14 | 196 |
| 50.05.0064 | Plate 40/6 | 117 | 53.00.0304 | Distributor Plate A24 | 196 |
| 50.05.0065 | Plate 40/7 | 117 | 53.00.0333 | Distributor Plate A14 | 196 |
| 50.05.0066 | Plate 40/8 | 117 | 53.00.0334 | Distributor Plate A24 | 196 |
| 50.05.0070 | Straight Plate 09 | 115 | 53.00.0352 | Supply Plate A | 196 |
| 50.05.0077 | Straight Plate 04 | 114 | 53.00.0353 | Supply Plate A | 196 |
| 50.05.6010 | Plate 60/10 | 120 | 53.01.0005 | Seal A | 197 |
| 50.05.6012 | Plate 60/12 | 120 | 53.01.0006 | Seal B | 197 |
| 50.05.6026 | Plate 60/26 | 120 | 5401BC.* | Profile Services | 179 |
| 50.09.0013 | Pad Plate A M10 | 161 | 5401CC* | Angle Brace 01 | 131 |
| 50.09.0017 | Cylinder Plate | 221 | 5402CA* | Angle Brace 02 | 131 |
| 50.09.0018 | Cylinder Plate | 221 | 5440BC.* | Profile Services | 179 |
| 50.09.0037 | Pad Plate 1 M20 | 161 | 5440CC* | Angle Brace 40 | 131 |
| 50.09.0038 | Pad Plate 3 M20 | 161 | 63.00.0011 | Step Washer | 192 |
| 50.09.0039 | Pad Plate I M20 | 161 | 63.00.0016 | Washer \varnothing 30 | 215 |
| 50.09.0040 | Plate 4 M20 | 168 | 63.03.0001 | Step Washer M8 | 221 |
| 50.09.0041 | Plate 5 M20 | 168 | 63.03.0003 | Step Washer M10 x 1,25 | 221 |
| 50.09.0044 | Pad Plate A M12 | 161 | 65.00.0001 | Cast Base 1 | 153 |
| 50.09.0045 | Pad Plate A M16 | 161 | 65.00.0005 | Cast Base 5 | 153 |
| 50.15.3005 | Alucobond Cut | 185 | 67.00.0002 | Pad Block M10 | 158 |
| 50.15.4001 | Alucobond Cut | 185 | 67.00.0003 | Pad Block M10 | 158 |
| 50.15.4002 | Alucobond Cut | 185 | 67.00.0010 | Pad Block M10 | 158 |
| 50.15.6000 | Acrylic Cut | 184 | 67.02.0004 | Fußstütze | 148 |
| 50.15.6001 | Acrylic Cut | 184 | 7000AA....* | Rod M8 \varnothing 12 | 217 |
| 50.15.6002 | Polycarbonate Cut | 184 | 7000AD.* | Rod \varnothing 12 | 217 |
| 50.15.6002 | Polycarbonate Cut | 184 | 7000AF.* | Guide Rod | 217 |
| 50.15.6003 | Polycarbonate Cut | 184 | 7000CA.* | Guide Rod | 217 |
| 50.15.6003 | Polycarbonate Cut | 184 | 7000CC.* | Guide Rod | 217 |
| 50.15.6009 | Polycarbonate Cut | 184 | 76.01.0002 | End Cap | 219 |
| 50.15.6014 | Acrylic Cut | 184 | 76.03.0018 | Anchor Plate | 180 |
| 50.15.6017 | PETG Cut | 184 | 76.03.0020 | Guide Angle | 180 |
| 50.15.6019 | PETG Cut | 184 | 79.00.0001 | Plug 5 | 127 |
| 53.00.0100 | End Plate A | 196 | 79.00.0004 | Plug 7 | 161 |

Index by Ident-No.

Article Index

| | | | | | |
|------------|------------------|-----|------------|----------------------------|-----|
| 79.00.0011 | T-Connector | 219 | 82.07.0041 | Angle D40s | 97 |
| 79.01.0001 | Corner Block 1 | 128 | 82.07.0042 | Angle D90s | 97 |
| 79.01.0002 | Corner Block 2 | 128 | 82.10.4001 | Angle L25 | 100 |
| 79.01.0003 | Corner Block 3 | 128 | 82.11.4001 | Angle M25 | 100 |
| 79.01.0004 | Corner Block 4 | 128 | 82.11.4041 | Angle M25s | 100 |
| 79.01.0005 | Corner Block 5 | 124 | 82.12.4001 | Angle N25 | 100 |
| 79.01.0006 | Corner Block 6 | 123 | 82.40.0701 | Angle E25 | 90 |
| 79.01.0052 | Corner Block 3 | 130 | 82.40.0702 | Angle E40 | 90 |
| 79.01.0054 | Corner Block 3 | 130 | 82.40.0703 | Angle E80 | 90 |
| 79.01.0055 | Corner Block 3 | 130 | 82.40.0704 | Angle E65 | 90 |
| 79.01.0062 | Corner Block 30° | 126 | 82.40.0705 | Angle E120 | 90 |
| 79.01.0066 | Corner Block 45° | 126 | 82.40.0741 | Angle E25s | 91 |
| 79.01.0068 | Corner Block 60° | 126 | 82.40.0742 | Angle E40s | 91 |
| 82.02.0001 | Angle A1 | 94 | 82.40.0744 | Angle E65s | 91 |
| 82.03.0001 | Angle A3 | 94 | 82.40.0747 | Angle E40s3 | 91 |
| 82.05.0003 | Angle B25 | 94 | 82.40.0801 | Angle F25 | 91 |
| 82.05.0004 | Angle B50 | 95 | 82.40.0802 | Angle F40 | 91 |
| 82.05.0006 | Angle B100 | 95 | 82.40.0803 | Angle F80 | 91 |
| 82.05.0012 | Angle B150 | 95 | 82.40.0804 | Angle F65 | 91 |
| 82.05.0013 | Angle B40 | 94 | 82.40.0805 | Angle F40/R | 91 |
| 82.05.0022 | Angle B90 | 95 | 82.40.0841 | Angle F25s | 92 |
| 82.05.0026 | Angle B20/40 | 95 | 82.40.0844 | Angle F65s | 92 |
| 82.05.0051 | Angle B50s1 | 95 | 82.40.0901 | Angle G25 | 92 |
| 82.05.0052 | Angle B50s2 | 95 | 82.40.0902 | Angle G40 | 92 |
| 82.05.0053 | Angle B50s3 | 95 | 82.40.0903 | Angle G80 | 92 |
| 82.05.0055 | Angle B40s2 | 95 | 82.40.0904 | Angle G65 | 92 |
| 82.06.0001 | Angle C25 | 96 | 82.40.0941 | Angle G25s | 92 |
| 82.06.0014 | Angle C40/3 | 96 | 82.40.0942 | Angle G65s | 92 |
| 82.06.0003 | Angle C90 | 96 | 82.60.0701 | Angle H40 | 98 |
| 82.06.0008 | Angle C40/2 | 96 | 82.60.0702 | Angle H100 | 98 |
| 82.06.0009 | Angle C90/2 | 96 | 82.60.0741 | Angle H40s | 98 |
| 82.06.0010 | Angle C140/2 | 96 | 82.60.0742 | Angle H100s | 98 |
| 82.06.0040 | Angle C25s | 96 | 82.60.0801 | Angle J40 | 99 |
| 82.06.0041 | Angle C40s | 96 | 82.60.0802 | Angle J100 | 99 |
| 82.06.0042 | Angle C90s | 96 | 82.60.0901 | Angle K40 | 99 |
| 82.07.0001 | Angle D25 | 97 | 82.60.0902 | Angle K100 | 99 |
| 82.07.0003 | Angle D90 | 97 | 82.60.0941 | Angle K40s | 99 |
| 82.07.0009 | Angle D90/2 | 97 | 82.60.0942 | Angle K100s | 99 |
| 82.07.0010 | Angle D140/2 | 97 | B02.99.151 | Groundconnection | 140 |
| 82.07.0013 | Angle D40/3 | 97 | B12.00.001 | Turntable with Index | 233 |
| 82.07.0040 | Angle D25s | 97 | B12.00.002 | Turntable with Fixed Stops | 233 |

Article Index

| | | | | | |
|------------|----------------------------|-----|------------|-------------------------|-----|
| B12.00.003 | Turntable without Index | 233 | B46.01.201 | Joint B01 | 209 |
| B28.00.001 | PHM-I 20 | 237 | B46.01.202 | Joint B02 | 209 |
| B28.00.002 | PHM-A 20 | 236 | B46.01.203 | Joint B03 | 209 |
| B34.01.001 | Panel Clamp 40 | 186 | B46.01.204 | Joint B04 | 209 |
| B34.01.002 | Panel Clamp 50 | 186 | B46.01.205 | Joint B05 | 209 |
| B40.03.002 | Bushing for Linear Bearing | 220 | B46.01.221 | Joint B21 | 208 |
| B46.00.020 | Adjustable Angles D25 | 103 | B46.01.222 | Joint B22 | 208 |
| B46.00.021 | Adjustable Angles B25 | 103 | B46.01.223 | Joint B23 | 208 |
| B46.00.024 | Adjustable Angles A25/3 | 102 | B46.01.224 | Joint B24 | 208 |
| B46.00.025 | Adjustable Angles A25/1 | 102 | B46.01.225 | Joint B25 | 208 |
| B46.00.026 | Adjustable Angles A25/2 | 102 | B46.01.250 | Joint B50 | 210 |
| B46.00.027 | Adjustable Angles C25 | 103 | B46.01.251 | Joint B51 | 210 |
| B46.00.032 | Adjustable Angles D25 | 103 | B46.01.252 | Joint B52 | 210 |
| B46.00.033 | Adjustable Angles B25 | 103 | B46.01.253 | Joint B53 | 211 |
| B46.00.034 | Adjustable Angles A25/3 | 102 | B46.01.254 | Joint B54 | 211 |
| B46.00.035 | Adjustable Angles A25/1 | 102 | B46.01.255 | Joint B55 | 211 |
| B46.00.036 | Adjustable Angles A25/2 | 102 | B46.02.004 | Clamp | 215 |
| B46.00.037 | Adjustable Angles C25 | 103 | B46.02.005 | Clamp | 215 |
| B46.00.041 | Angle R40 | 93 | B46.02.010 | Ball Base C1 | 213 |
| B46.01.001 | Hinge 50-1/50-1 | 173 | B46.02.011 | Ball Base C2 | 213 |
| B46.01.002 | Hinge 50-2/50-2 | 173 | B46.02.012 | Ball Base C3 | 213 |
| B46.01.010 | Hinge 40-1/40-1 | 173 | B46.03.003 | Drill Fixture Series 25 | 226 |
| B46.01.011 | Hinge 40-1/50-1 | 173 | B46.03.007 | Drill Fixture | 227 |
| B46.01.012 | Hinge 25-1/25-1 | 172 | B46.03.102 | Parting Tool | 225 |
| B46.01.013 | Hinge 25-1/25-1 | 172 | B46.05.001 | Corner Block 30 | 121 |
| B46.01.014 | Hinge 25-1/50-1 | 174 | B46.05.002 | Corner Block 31 | 122 |
| B46.01.015 | Hinge 25 | 175 | B46.05.003 | Corner Block 32 | 122 |
| B46.01.022 | Joint 40/H1 | 218 | B46.05.004 | Corner Block 33 | 122 |
| B46.01.023 | Joint 40/H2 | 218 | B46.05.005 | Corner Block 34 | 122 |
| B46.01.024 | Joint 40/H3 | 219 | B46.05.006 | Corner Block 35 | 122 |
| B46.01.025 | Joint 40/H4 | 218 | B46.05.007 | Corner Block 36 | 122 |
| B46.01.026 | Joint 40/H5 | 219 | B46.05.008 | Corner Block 37 | 122 |
| B46.01.030 | Hinge 40-1/40-7/40-1 | 173 | B46.05.009 | Corner Block 38 | 122 |
| B46.01.033 | Hinge | 175 | B46.05.039 | Corner Block 46 | 124 |
| B46.01.044 | Hinge 25-1/25-3 | 176 | B46.05.040 | Corner Block 39 | 124 |
| B46.01.050 | Hinge 40-1/40-3 | 176 | B46.05.041 | Corner Block 40 | 124 |
| B46.01.055 | Hinge 50-1/40-3 | 176 | B46.05.042 | Corner Block 41 | 124 |
| B46.01.058 | Hinge 60-1/60-1 | 174 | B46.05.043 | Corner Block 42 | 124 |
| B46.01.059 | Hinge 60-1/60-2/60-1 | 174 | B46.05.044 | Corner Block 43 | 124 |
| B46.01.063 | Hinge 40-1/60-1 | 174 | B46.05.045 | Corner Block 44 | 124 |
| B46.01.064 | Hinge 50-1/60-1 | 173 | B46.05.047 | Corner Block 47 | 125 |

Index by Ident-No.

Article Index

| | | | | | |
|------------|--------------------------------|-----|------------|----------------------------|-----|
| B46.05.048 | Corner Block 48 | 125 | B67.02.010 | Pad Angle M16 | 158 |
| B46.05.049 | Corner Block 49 | 125 | B67.02.027 | Leveling Pad KC M12 | 163 |
| B46.07.090 | Face Plate 40 | 112 | B67.02.028 | Leveling Pad KC M16 | 163 |
| B46.07.095 | Face Plate 50 | 112 | B67.02.030 | Leveling Pad GC M20 | 164 |
| B46.07.274 | Pedestal Base 6 | 155 | B67.02.031 | Leveling Pad GB M20 | 164 |
| B46.07.275 | Pedestal Base 7 | 155 | B67.02.032 | Leveling Pad GB M16 | 164 |
| B46.07.276 | Pedestal Base 8 | 155 | B67.02.033 | Leveling Pad GE M20 | 164 |
| B46.07.277 | Pedestal Base 9 | 155 | B67.02.034 | Leveling Pad GE M20 | 164 |
| B51.03.003 | Corner Block 1 | 128 | B67.02.040 | Leveling Pad EB M16 | 164 |
| B51.03.004 | Tension Plug Series 40 | 108 | B67.02.057 | Leveling Pad KA M10 | 163 |
| B51.03.005 | Drill Fixture Series 40 and 50 | 226 | B67.02.075 | Leveling Pad KB M12 | 163 |
| B51.03.006 | Tension Plug | 110 | B67.02.076 | Leveling Pad M12 | 163 |
| B51.03.009 | Tension Plug Series 25 | 108 | B67.02.077 | Leveling Pad KC M12 | 163 |
| B51.03.010 | Swivel Tension Plug | 111 | B68.02.007 | Catch | 178 |
| B51.03.011 | Swivel Tension Plug | 111 | B68.02.017 | External Double-Bit Lock | 178 |
| B51.03.016 | Parallel Connector S. 50 | 132 | B68.02.018 | External Double-Bit Lock | 178 |
| B51.03.017 | Parallel Connector S. 40 | 132 | B68.02.019 | External Cylinder Lock | 178 |
| B51.03.018 | Parallel Connector | 132 | B68.02.020 | External Cylinder Lock | 178 |
| B51.03.020 | Drill Fixture Cleanroom 40 | 228 | B68.02.051 | Cylinder Lock | 179 |
| B51.03.030 | Tension Plug Series 40 | 108 | B68.02.052 | Cylinder Lock | 179 |
| B51.03.035 | Drill Fixture Cleanroom 50 | 228 | B68.02.151 | Upper Slide Bolt | 180 |
| B51.03.036 | Tension Plug S. 40 | 109 | B68.02.152 | Lower Slide Bolt | 180 |
| B51.03.037 | Tension Plug S. 40 | 109 | B68.06.005 | Catch | 178 |
| B60.00.001 | Flange Roller 1 | 193 | B68.11.003 | Guide for Sliding Door | 181 |
| B60.00.002 | Flange Roller 2 | 193 | B90.00.002 | Carriage Wagons mk 2004 | 234 |
| B60.00.003 | Flange Roller A1 | 194 | B90.00.015 | Carriage Wagons mk 2000 | 235 |
| B60.00.004 | Flange Roller A1 | 194 | B90.40.001 | Carriage Wagons mk 2040.02 | 234 |
| B60.01.001 | Roller | 193 | D05625 | Nut M5 | 138 |
| B60.01.003 | Roller A4 | 194 | D058016 | Eye Bolt M16 | 168 |
| B60.01.005 | Roller A4 | 194 | D058020 | Eye Bolt M20 | 168 |
| B60.02.002 | Guide Roller A2 | 194 | D09121220 | SHCS M12 x 20 | 141 |
| B60.02.019 | Guide Roller A2 | 194 | D09121225 | SHCS M12 x 20 | 141 |
| B60.04.002 | mk Mini-Roller | 192 | D0912410 | SHCS M4 x 10 | 141 |
| B60.04.004 | Roller Unit | 235 | D0912510 | SHCS M5 x 10 | 141 |
| B67.02.001 | Leveling Pad KB M12 | 163 | D0912512 | SHCS M5 x 12 | 141 |
| B67.02.002 | Leveling Pad KB M16 | 163 | D0912516 | SHCS M5 x 16 | 141 |
| B67.02.003 | Leveling Pad GA M16 | 164 | D091258 | SHCS M5 x 8 | 141 |
| B67.02.004 | Leveling Pad GA M20 | 164 | D0912610 | SHCS M6 x 10 | 141 |
| B67.02.005 | Leveling Pad GD M16 | 164 | D0912612 | SHCS M6 x 12 | 141 |
| B67.02.006 | Leveling Pad GD M20 | 164 | D0912616 | SHCS M6 x 16 | 141 |
| B67.02.009 | Pad Angle M12 | 158 | D0912620 | SHCS M6 x 20 | 141 |

Article Index

| | | | | | |
|------------|-------------------------|-----|------------|------------------------|-----|
| D0912812 | SHCS M8 x 12 | 141 | D0933820A2 | Hex Head Screw M8 x 20 | 142 |
| D0912816 | SHCS M8 x 16 | 141 | D0933825 | Hex Head Screw M8 x 25 | 142 |
| D0912816A2 | SHCS M8 x 16 | 141 | D0933825A2 | Hex Head Screw M8 x 25 | 142 |
| D0912820 | SHCS M8 x 20 | 141 | D0933830 | Hex Head Screw M8 x 30 | 142 |
| D0912820A2 | SHCS M8 x 20 | 141 | D0933835 | Hex Head Screw M8 x 35 | 142 |
| D0912825 | SHCS M8 x 25 | 141 | D0933840 | Hex Head Screw M8 x 40 | 142 |
| D0912830 | SHCS M8 x 30 | 141 | D093410 | Hex Nut M10 | 142 |
| D0912835 | SHCS M8 x 35 | 141 | D093412 | Hex Nut M12 | 142 |
| D0912840 | SHCS M8 x 40 | 141 | D09345 | Hex Nut M5 | 142 |
| D0914410 | Set Screw M4 x 10 | 142 | D09345A2 | Hex Nut M5 | 142 |
| D091446 | Set Screw M4 x 6 | 142 | D09346 | Hex Nut M6 | 142 |
| D091448 | Set Screw M4 x 8 | 142 | D09346A2 | Hex Nut M6 | 142 |
| D0914510 | Set Screw M5 x 10 | 142 | D09348 | Hex Nut M8 | 142 |
| D091456 | Set Screw M5 x 6 | 142 | D09348A2 | Hex Nut M8 | 142 |
| D091458 | Set Screw M5 x 8 | 142 | D67968 | Spring Washer | 109 |
| D0914610 | Set Screw M6 x 10 | 142 | D69121025 | SHCS M10 x 25 | 141 |
| D0914610A2 | Set Screw M6 x 10 | 142 | D69121230 | SHCS M12 x 30 | 141 |
| D091466 | Set Screw M6 x 6 | 142 | D6912510 | SHCS M5 x 10 | 141 |
| D091466A2 | Set Screw M6 x 6 | 142 | D6912512 | SHCS M5 x 12 | 141 |
| D091468 | Set Screw M6 x 8 | 142 | D6912520 | SHCS M5 x 20 | 141 |
| D091468A2 | Set Screw M6 x 8 | 142 | D691258 | SHCS M5 x 8 | 141 |
| D0914810 | Set Screw M8 x 10 | 142 | D6912616 | SHCS M6 x 16 | 141 |
| D0914810A2 | Set Screw M8 x 10 | 142 | D6912620 | SHCS M6 x 20 | 141 |
| D0914812 | Set Screw M8 x 12 | 142 | D6912816 | SHCS M8 x 16 | 141 |
| D0914816 | Set Screw M8 x 16 | 142 | D6912816A2 | SHCS M8 x 16 | 141 |
| D0914816A2 | Set Screw M8 x 16 | 142 | D6912820 | SHCS | 109 |
| D0914820 | Set Screw M8 x 20 | 142 | D6912820 | SHCS | 141 |
| D09331020 | Hex Head Screw M10 x 20 | 142 | D6912820A2 | SHCS | 109 |
| D09331025 | Hex Head Screw M10 x 25 | 142 | D6912820A2 | SHCS | 141 |
| D09331030 | Hex Head Screw M10 x 30 | 142 | D6912825 | SHCS M8 x 25 | 141 |
| D09331230 | Hex Head Screw M12 x 30 | 142 | D6912830 | SHCS M8 x 30 | 141 |
| D0933616 | Hex Head Screw M6 x 16 | 142 | D7991410 | FH-SHCS M4 x 10 | 141 |
| D0933620 | Hex Head Screw M6 x 20 | 142 | D7991410A2 | FH-SHCS M4 x 10 | 141 |
| D0933625 | Hex Head Screw M6 x 25 | 142 | D7991412 | FH-SHCS M4 x 12 | 141 |
| D0933630 | Hex Head Screw M6 x 30 | 142 | D7991416 | FH-SHCS M4 x 16 | 141 |
| D0933635 | Hex Head Screw M6 x 35 | 142 | D7991416A2 | FH-SHCS M4 x 16 | 141 |
| D093368 | Hex Head Screw M6 x 8 | 142 | D7991435A2 | FH-SHCS M4 x 35 | 141 |
| D0933812 | Hex Head Screw M8 x 12 | 142 | D799146 | FH-SHCS M4 x 6 | 141 |
| D0933816 | Hex Head Screw M8 x 16 | 142 | D7991510 | FH-SHCS M5 x 10 | 141 |
| D0933816A2 | Hex Head Screw M8 x 16 | 142 | D7991510A2 | FH-SHCS M5 x 10 | 141 |
| D0933820 | Hex Head Screw M8 x 20 | 142 | D7991512 | FH-SHCS M5 x 12 | 141 |

Index by Ident-No.

Article Index

| | | | | | |
|--------------|------------------------------|-----|------------|---------------------------|-----|
| D7991516 | FH-SHCS M5 x 16 | 141 | K110000010 | Handle | 170 |
| D7991525 | FH-SHCS M5 x 25 | 141 | K110000011 | Handle | 170 |
| D799158 | FH-SHCS M5 x 8 | 141 | K110000012 | Handle | 170 |
| D799158A2 | FH-SHCS M5 x 8 | 141 | K110000013 | Handle | 170 |
| D7991610 | FH-SHCS M6 x 10 | 141 | K110000020 | Handle | 170 |
| D7991612 | FH-SHCS M6 x 12 | 141 | K110000021 | Handle | 170 |
| D7991612A2 | FH-SHCS M6 x 12 | 141 | K110020028 | Handwheel | 169 |
| D7991616 | FH-SHCS M6 x 16 | 141 | K110020030 | Handwheel | 169 |
| D7991616A2 | FH-SHCS M6 x 16 | 141 | K110020031 | Handwheel | 169 |
| D7991620 | FH-SHCS M6 x 20 | 141 | K110030055 | Adjustable Handle M8 x 15 | 171 |
| D7991812 | FH-SHCS M8 x 12 | 141 | K110030056 | Adjustable Handle M8 x 20 | 171 |
| D7991816 | FH-SHCS M8 x 16 | 141 | K110030057 | Adjustable Handle M8 x 25 | 171 |
| D7991816A2 | FH-SHCS M8 x 16 | 141 | K110030200 | Adjustable Handle M6 x 15 | 171 |
| D7991820 | FH-SHCS M8 x 20 | 141 | K110030201 | Adjustable Handle M6 x 20 | 171 |
| D7991820A2 | FH-SHCS M8 x 20 | 141 | K110030202 | Adjustable Handle M6 x 25 | 171 |
| D7991825 | FH-SHCS M8 x 25 | 141 | K110030204 | Adjustable Handle M8 x 15 | 171 |
| D7991830 | FH-SHCS M8 x 30 | 141 | K110030205 | Adjustable Handle M8 x 20 | 171 |
| D7991835A2 | FH-SHCS M8 x 35 | 141 | K110030206 | Adjustable Handle M8 x 25 | 171 |
| K00112121150 | Steel Material | 185 | K110060003 | Leveling Screw M10 | 163 |
| K00112131150 | Steel Material | 185 | K110060004 | Leveling Screw M8 | 163 |
| K00128222.40 | Fencing Steel Material | 184 | K111010014 | Ribbed Washer ø 43 | 142 |
| K00128321.40 | Fencing Material | 185 | K111010015 | Ribbed Washer ø 53 | 142 |
| K00205121150 | Stainless Steel Material | 185 | K111010016 | Ribbed Washer ø 64 | 142 |
| K00305321150 | Aluminum Material | 185 | K111010017 | Ribbed Washer ø 84 | 142 |
| K00305321200 | Aluminum Material | 185 | K111010018 | Ribbed Washer ø 105 | 142 |
| K00315122.40 | Fencing Alu Material | 184 | K111010019 | Ribbed Washer ø 12 | 142 |
| K00316222004 | Alucobond Material | 185 | K111010020 | Ribbed Washer ø 43 | 142 |
| K00316222004 | Alucobond Material | 185 | K111010021 | Ribbed Washer ø 53 | 142 |
| K00316222006 | Alucobond Material | 185 | K111010022 | Ribbed Washer ø 64 | 142 |
| K01B211004 | Polycarbonate clear Material | 184 | K111010023 | Ribbed Washer ø 84 | 142 |
| K01B211005 | Polycarbonate clear Material | 184 | K111010024 | Ribbed Washer ø 105 | 142 |
| K01B211006 | Polycarbonate clear Material | 184 | K111010025 | Ribbed Washer ø 12 | 142 |
| K01B231005 | Polycarbonate grey Material | 184 | K111020006 | Clip M4 | 138 |
| K01B231006 | Polycarbonate grey Material | 184 | K111020007 | Clip M5 | 138 |
| K01D211004 | Acrylic Material | 184 | K111020008 | Clip M6 | 138 |
| K01D211005 | Acrylic Material | 184 | K112010002 | FBH-Screw | 141 |
| K01D211006 | Acrylic Material | 184 | K112010003 | FBH-Screw | 141 |
| K01P211005 | PETG Material | 184 | K112010004 | FBH-Screw | 141 |
| K01P211006 | PETG Material | 184 | K112010010 | FBH-Screw | 141 |
| K101120001 | mk Mini-Roller | 192 | K112010011 | FBH-Screw | 141 |
| K110000009 | Handle | 170 | K112010012 | FBH-Screw | 141 |

Article Index

| | | | | | |
|------------|-----------------------------------|-----|------------|--------------------------|-----|
| K112010013 | FBH-Screw | 141 | K903000090 | Twist-Drill | 224 |
| K112010021 | FBH-Screw | 141 | K903000100 | Twist-Drill | 224 |
| K112030008 | Threaded Insert M8 | 109 | K903060005 | Tap M 5 | 224 |
| K113060001 | Bumper Type D M6x15 | 222 | K903060008 | Tap M 8 | 224 |
| K113060002 | Bumper Type D M8x20 | 222 | K903060010 | Tap M 10 | 224 |
| K113060003 | Bumper Type D M10x28 | 222 | K903060012 | Tap M 12 | 224 |
| K113060004 | Bumper Type D M6x12 | 222 | K903060016 | Tap M 16 | 224 |
| K113060006 | Bumper Type K/D M6x18 | 222 | K903060105 | Tap M 5 x 05 | 224 |
| K113060007 | Bumper Type K/D M10x28 | 222 | K903060108 | Tap M 8 x 1 | 224 |
| K113060011 | Bumper Type KP/D M8x20 | 222 | K903060109 | Tap M 9 x 1 | 224 |
| K113060012 | Bumper Type KP/D M8x10 | 222 | K903060113 | Tap M 12 x 1,5 | 224 |
| K115010093 | O-Ring ø 12x2 mm | 197 | K903060116 | Tap M 16 x 1,5 | 224 |
| K502050351 | Polyamide Seal | 197 | K903060204 | Tap for Helicoil inserts | 224 |
| K502050353 | Polyamide Seal | 197 | K903060206 | Tap for Helicoil inserts | 224 |
| K502050426 | Closure Screw | 197 | K903060208 | Tap for Helicoil inserts | 224 |
| K502050428 | Closure Screw | 197 | K903060210 | Tap for Helicoil inserts | 224 |
| K502050450 | Closure Screw | 197 | K903070008 | Tap M 8 | 224 |
| K502050451 | Closure Screw | 197 | mk 2060.30 | Closure Strip | 182 |
| K502050700 | Coupling | 197 | mk 2500 | End Cap | 202 |
| K502050705 | Coupling | 197 | mk 2501 | End Cap | 202 |
| K502050706 | Coupling | 197 | mk 2502 | End Cap | 201 |
| K901130001 | Magnetic Holder | 225 | mk 2503 | End Cap | 202 |
| K902005050 | Wrench Set 8-piece | 225 | mk 2504 | End Cap | 202 |
| K902010004 | Insert Tools | 224 | mk 2505 | End Cap | 202 |
| K902010005 | Insert Tools | 224 | mk 2507 | End Cap | 201 |
| K902010008 | Insert Tools | 224 | mk 2508 | End Cap | 201 |
| K902010009 | Insert Tools | 224 | mk 2522 | Clamp | 215 |
| K902010010 | Insert Tools | 224 | mk 2523 | End Cap | 201 |
| K902010011 | Insert Tools | 224 | mk 2524 | End Cap | 202 |
| K902010012 | Insert Tools | 224 | mk 2529 | End Cap | 201 |
| K902010013 | Insert Tools | 224 | mk 2544 | Fence Clip | 187 |
| K902010016 | Insert Tools | 224 | mk 2546 | Clip 40 | 199 |
| K902010017 | Insert Tools | 224 | mk 2550 | Clip 50 | 199 |
| K902010204 | Insert Tools for Helicoil inserts | 224 | mk 2552 | Panel Block | 186 |
| K902010206 | Insert Tools for Helicoil inserts | 224 | mk 2553 | Nut Stopper green | 139 |
| K902010208 | Insert Tools for Helicoil inserts | 224 | mk 2554 | Nut Stopper white | 139 |
| K902010210 | Insert Tools for Helicoil inserts | 224 | mk 2555 | Nut Stopper red | 139 |
| K902030001 | Deburring Block | 225 | mk 2556 | Nut Stopper yellow | 139 |
| K903000058 | Twist-Drill | 224 | mk 2557 | Nut Stopper blue | 139 |
| K903000070 | Twist-Drill | 224 | mk 2559 | Nut Stopper orange | 139 |
| K903000080 | Twist-Drill | 224 | mk 2560 | Nut Stopper violet | 139 |

Index by Ident-No.

Article Index

| | | | | | |
|------------|--------------------------|-----|-------------|----------------------------|-----|
| mk 2561 | End Cap | 203 | T25.50.1000 | Angle 15 complete | 88 |
| mk 2562 | End Cap | 203 | T25.50.1001 | Angle 40 complete | 88 |
| mk 2563 | End Cap | 203 | T25.50.1010 | Angle S15 complete | 89 |
| mk 3010 | Closure Strip | 182 | T25.50.1012 | Angle S40 complete | 89 |
| mk 3011 | Seal Strip | 183 | T25.50.1020 | Angle A25/15/2 complete | 88 |
| mk 3012 | Closure Strip black | 182 | T25.50.1021 | Angle A25/40/2 complete | 88 |
| mk 3013 | Closure Strip grey | 182 | T25.50.3000 | Straight Plate 01 complete | 113 |
| mk 3014 | Closure Strip blue | 182 | T25.50.3001 | Straight Plate 02 complete | 113 |
| mk 3015 | Closure Strip yellow | 182 | T25.50.3002 | Angle Plate 01 complete | 113 |
| mk 3016 | Closure Strip green | 182 | T25.50.3006 | T-Plate 01 complete | 113 |
| mk 3017 | Closure Strip red | 182 | T50.05.0045 | Angle Plate 03 complete | 115 |
| mk 3019 | Closure Strip grey | 182 | T50.05.0046 | T-Plate 03 complete | 115 |
| mk 3020 | Seal Strip | 183 | T50.05.0047 | Straight Plate 07 complete | 114 |
| mk 3021 | Seal Strip | 183 | T50.05.0051 | Angle Plate 13 complete | 115 |
| mk 3023 | Seal Strip | 183 | T50.05.0052 | Straight Plate 03 complete | 114 |
| mk 3024 | Seal Strip | 183 | T50.05.0053 | Straight Plate 05 complete | 114 |
| mk 3025 | Seal Strip | 183 | T50.05.0070 | Straight Plate 09 complete | 115 |
| mk 3026 | Closure Strip | 182 | T50.05.0077 | Straight Plate 04 complete | 114 |
| mk 3027 | Seal Strip | 183 | T82.05.0003 | Angle B25 complete | 94 |
| mk 3030 | Seal Strip | 183 | T82.05.0004 | Angle B50 complete | 95 |
| mk 3032 | Closure Strip | 183 | T82.05.0006 | Angle B100 complete | 95 |
| mk 3033 | Seal Strip | 183 | T82.05.0013 | Angle B40 complete | 94 |
| mk 3034 | Seal Strip | 189 | T82.05.0022 | Angle B90 complete | 95 |
| mk 3035 | Closure Strip | 183 | T82.05.0026 | Angle B20/40 complete | 95 |
| mk 3036 | Closure Strip | 183 | T82.05.0051 | Angle B50s1 complete | 95 |
| P57.01.000 | Stainless Steel Material | 185 | T82.05.0052 | Angle B50s2 complete | 95 |
| P57.02.000 | Steel Material | 185 | T82.05.0053 | Angle B50s3 complete | 95 |
| P90.00.007 | Fencing Material | 185 | T82.05.0055 | Angle B40s2 complete | 95 |
| P90.00.008 | Fencing Material | 185 | T82.06.0001 | Angle C25 complete | 96 |
| P90.00.009 | Fencing Material | 185 | T82.06.0040 | Angle C25s complete | 96 |
| P90.00.010 | Fencing Material | 185 | T82.06.0041 | Angle C40s complete | 96 |
| P90.03.002 | Polycarbonate Material | 184 | T82.07.0001 | Angle D25 complete | 97 |
| P90.03.003 | Polycarbonate Material | 184 | T82.07.0040 | Angle D25s complete | 97 |
| P90.04.001 | Alumalite Material | 185 | T82.07.0041 | Angle D40s complete | 97 |
| P90.05.001 | Acrylic Material | 184 | T82.40.0701 | Angle E25 complete | 90 |
| P90.06.001 | Dibond Material | 185 | T82.40.0702 | Angle E40 complete | 90 |
| P90.07.001 | PVC Material | 185 | T82.40.0703 | Angle E80 complete | 90 |
| P90.07.002 | PVC Material | 185 | T82.40.0704 | Angle E65 complete | 90 |
| P90.07.003 | PVC Material | 185 | T82.40.0741 | Angle E25s complete | 91 |
| P90.07.004 | PVC Material | 185 | T82.40.0742 | Angle E40s complete | 91 |
| P90.08.001 | Trespa silver | 184 | T82.40.0744 | Angle E65s complete | 91 |

Article Index

| | | |
|-------------|----------------------|----|
| T82.40.0747 | Angle E40s3 complete | 91 |
| T82.40.0801 | Angle F25 complete | 91 |
| T82.40.0802 | Angle F40 complete | 91 |
| T82.40.0803 | Angle F80 complete | 91 |
| T82.40.0804 | Angle F65 complete | 91 |
| T82.40.0805 | Angle F40/R complete | 91 |
| T82.40.0841 | Angle F25s complete | 92 |
| T82.40.0844 | Angle F65s complete | 92 |
| T82.40.0901 | Angle G25 complete | 92 |
| T82.40.0902 | Angle G40 complete | 92 |
| T82.40.0903 | Angle G80 complete | 92 |
| T82.40.0904 | Angle G65 complete | 92 |
| T82.40.0941 | Angle G25s complete | 92 |
| T82.40.0942 | Angle G65s complete | 92 |

Notes

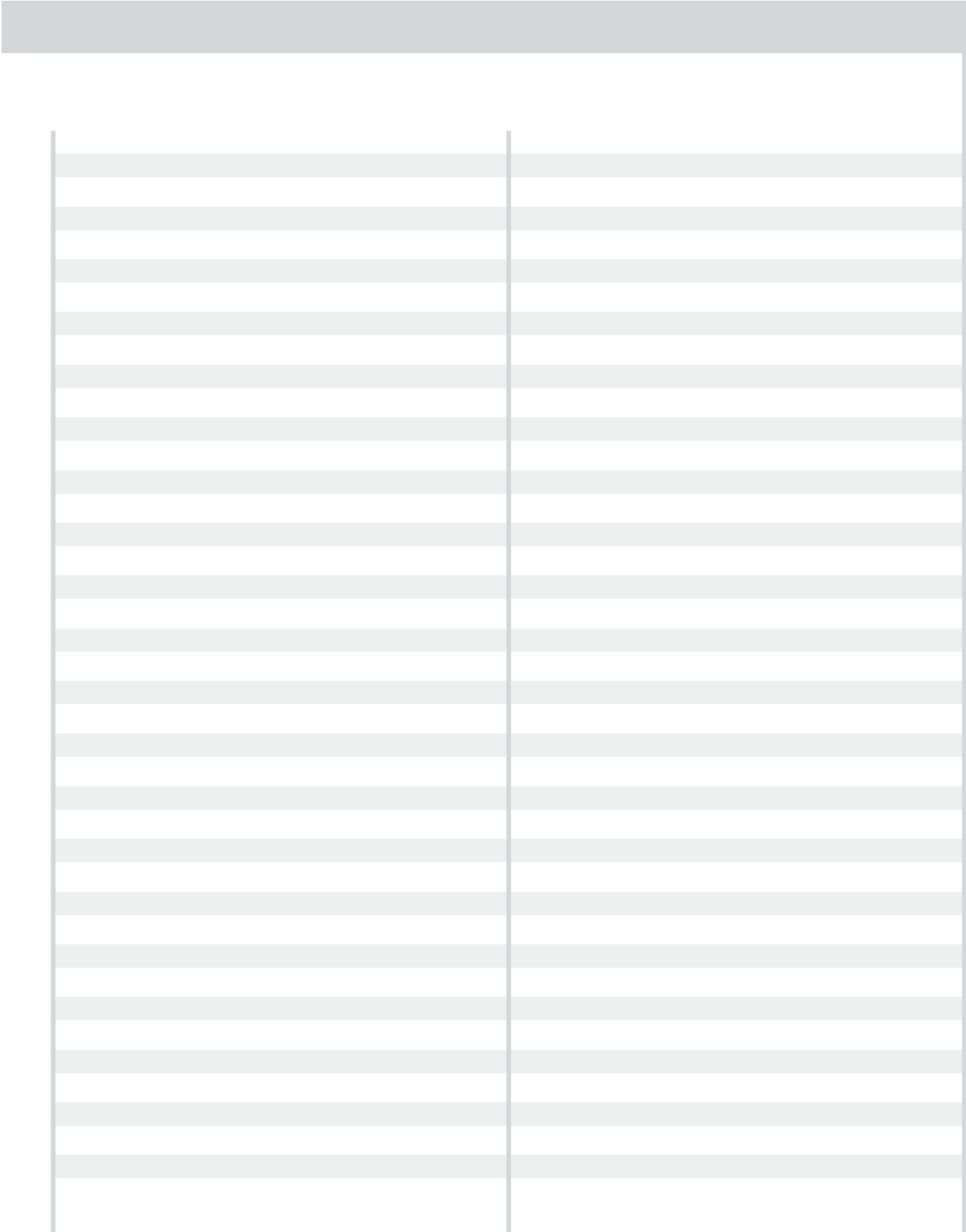

A large rectangular area with a gray header bar at the top and a grid of horizontal lines below, intended for writing notes. The grid consists of 20 horizontal rows, each with a light gray background, separated by thin white lines. A vertical gray line divides the grid into two columns of approximately equal width.



Maschinenbau Kitz GmbH
Glockenstraße 84
53844 Troisdorf
Germany
Phone +49 228 4598-0
Fax +49 228 453145
www.mk-group.com
info@mk-group.com