



AC SERVO DRIVES DIRECT DRIVE Σ SERIES

SERVOMOTOR MODEL SGMCS
SERVOPACK MODEL SGDS
SGDH



Powerful
&
Simple

Certified for
ISO9001 and
ISO14001



JQA-0422

JQA-EM0202

JQA-EM0924

With a full product lineup, **we have the answer** that can meet your needs for compact drive systems with high torque and high accuracy.

For your ideal machine, you need a compact servo drive with high torque and high accuracy. Your dream can come true with Yaskawa's gearless, direct-drive Σ series.

Use a direct drive to supply high torque at low speeds, obtain precise positioning at high speeds without any slippage and backlash, and simplify your machine's configuration and maintenance. With a wide variety of products in our lineup, you have an expanded range of applications to choose from.

Use Yaskawa's Σ series of gearless direct drives to make your ideal machine a reality.



Powerful & Simple

Advantage
1

More powerful with higher positioning accuracy

! High torque and High speed —

- A high-torque operation is realized at low speeds without gears.
Instantaneous peak torque : 6 N·m to 600 N·m
- A high-speed operation reduces cycle time.
Maximum motor speed : 250 min⁻¹ to 500 min⁻¹

! High precision —

- High-precision indexing of 1,000,000 pulses per rotation (P/R) is available.
High-resolution encoder(20-bit): 1,048,576 P/R
- No backlash means that high-precision operation with shorter settling time is possible with high frequency use.
- A current control algorithm with conversions for the d-q axis realizes higher accuracy in torque control.

Advantage
2

Simplified machine configuration, adjustment, and maintenance

! Compact —

- The size of the machine's drive section is reduced because of the slim motor design.
- The hollow space in the motor can be used for wiring and piping.

! Easy —

- Smooth and noiseless drive.
- Use of a serial encoder reduces the amount of wiring.
- The gearless drive requires no maintenance for lubrication or any inspections for wear and tear.
- Parameters are used to change the type of control being used: speed control, torque control, or position control.

Comparison of drive systems for rotary tables

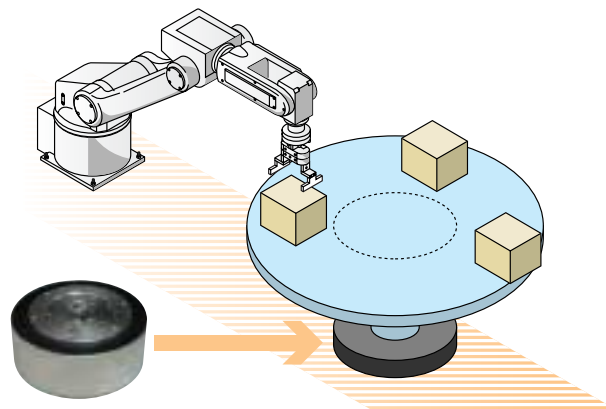

Typical servo drive system

<Current limitations>

- Reduced accuracy in positioning with excessive slippage and backlash
- Noise
- Maintenance for wear and tear or for lubrication

■ Motor with Gear

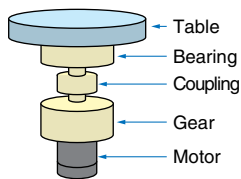

■ Motor + Timing Belt

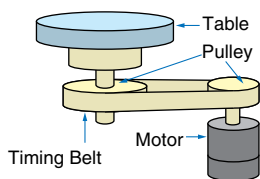

■ Hollow Motor + Hollow Gear

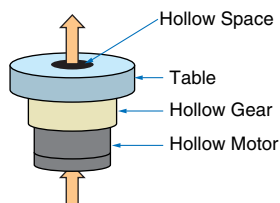

Direct drive system

<Technical improvements>

A drive system without reducers, such as gears and pulleys, eliminates practical difficulties and helps make the machine smaller. Some advantages are:

- Improved positioning accuracy with direct connection to a load
- Low noise
- Clean room use (No gear means no lubrication.)
- Reduced number of parts
- Easy wiring and piping based on the motor's hollow design

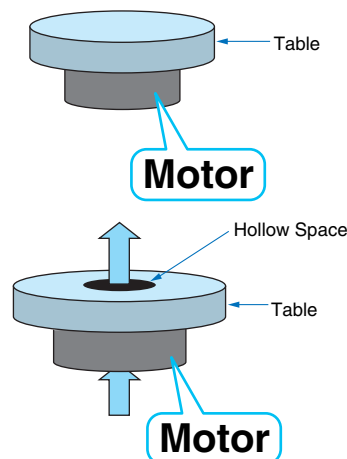

Applications

- Semiconductor-manufacturing machines
- Machines for the manufacturing of liquid-crystal circuit boards
- Units for inspection and testing
- Electronic parts assembling machines
- IC handlers
- Inspection units for integrated circuits
- Automated machines
- Manipulator

CONTENTS

	page
Product Lineup	4
System Configuration	6
Servomotors	7
Small Capacity	
Medium Capacity	
SERVOPACKs	21
Connection Diagrams	26
Ordering Reference	29

Product Lineup

● Small Capacity



Motor Outer Diameter (Inner Diameter) mm	Motor Model	Torque 20 40 60 80 100N·m (Rated torque/Peak torque) Unit: N·m	SGDS-		SGDH-	
			Single-phase 100 V	Single-phase 200 V	Single-phase 200 V	Three-phase 200 V
φ135 (φ20)	SGMCS-02B	(2.0/6.0)				
	SGMCS-05B	(5.0/15.0)	02F□□A	02A□□A	02AE	—
	SGMCS-07B	(7.0/21.0)				
φ175 (φ35)	SGMCS-04C	(4.0/12.0)				
	SGMCS-10C	(10.0/30.0)	04F□□A	04A□□A	04AE	—
	SGMCS-14C	(14.0/42.0)				
φ230 (φ60)	SGMCS-08D	(8.0/24.0)				
	SGMCS-17D	(17.0/51.0)	04F□□A	04A□□A	04AE	—
	SGMCS-25D	(25.0/75.0)				
φ290 (φ75)	SGMCS-16E	(16.0/48.0)				
	SGMCS-35E	(35.0/105.0)	—	08A□□A	—	08AE

● Medium Capacity



Motor Outer Diameter (Inner Diameter) mm	Motor Model	Torque 200 400 600N·m (Rated torque/Peak torque) Unit: N·m	SGDS-	SGDH-
			Three-phase 200 V	Three-phase 200 V
φ280 (φ75)	SGMCS-45M	(45/135)	10A□□A	10AE
	SGMCS-80M	(80/240)	15A□□A	15AE
	SGMCS-1AM	(110/330)	20A□□A	20AE
φ360 (φ118)	SGMCS-80N	(80/240)	15A□□A	15AE
	SGMCS-1EN	(150/450)	30A□□A	30AE
	SGMCS-2ZN	(200/600)	30A□□A	30AE

Model Designations

Servomotor

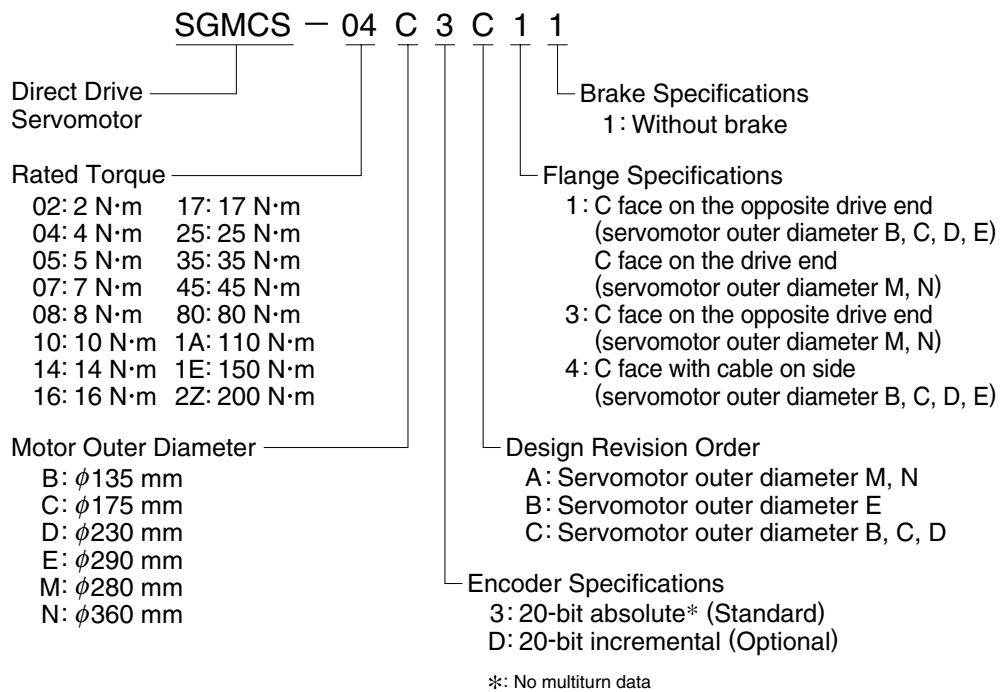

SERVOPACK

SGDS

Σ -III series
SGDS SERVOPACK

Maximum Applicable
Servomotor Capacity

A5: 50 W	10: 1.0 kW
01: 100 W	15: 1.5 kW
02: 200 W	20: 2.0 kW
04: 400 W	30: 3.0 kW
08: 750 W	

SGDS - 02 A 01 A

Mounting Method

Blank: Base mounted
R : Rack mounted

Design Revision Order
A, B, ... Starts from A

Interface Specifications
01: Standard (analog voltage/pulse train reference type)

Power Supply Voltage
A: 200 VAC
F: 100 VAC

SGDH

Σ -II series
SGDH SERVOPACK
(extended function)

Maximum Applicable
Servomotor Capacity

02: 200 W	10: 1.0 kW
04: 400 W	15: 1.5 kW
08: 750 W	20: 2.0 kW
	30: 3.0 kW

SGDH - 02 A E

Control Model
E: Speed, torque, and position control

Power Supply Voltage
A: 200 VAC

Note: SGDH software version must be 32 or later.

System Configuration

Refer to pages 27 to 31 for details of peripheral devices, connectors, and cables.

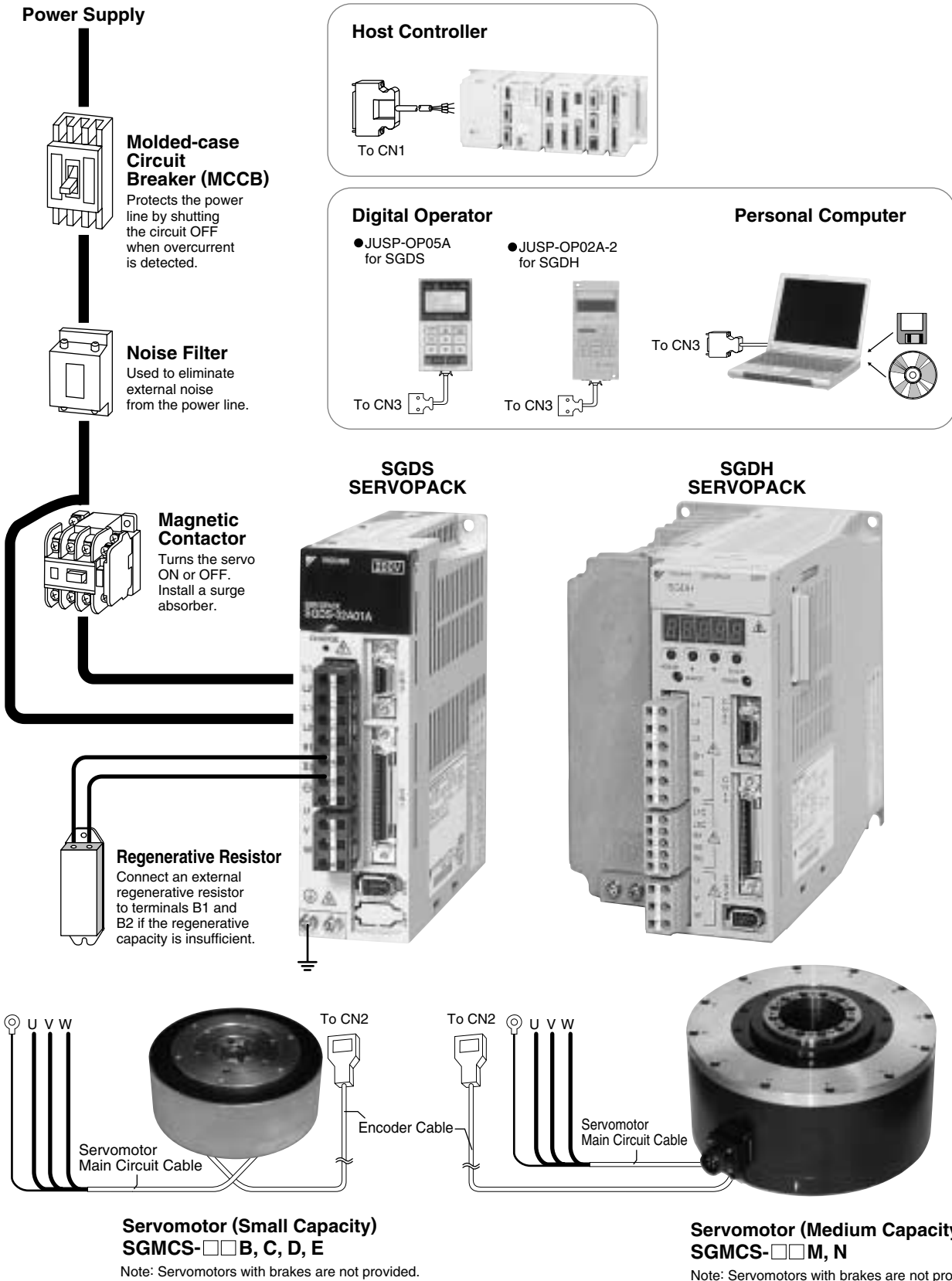

Servomotors (Small Capacity)



Ratings and Specifications

Time Rating : Continuous	Ambient Temperature : 0 to +40°C
Thermal Class : A	Ambient Humidity : 20% to 80% (no condensation)
Withstand Voltage : 1500 VAC for one minute	Excitation : Permanent magnet
Insulation Resistance : 500 VDC, 10 M Ω min.	Drive Method : Direct drive
Enclosure : Totally-enclosed, self-cooled	Mounting : Flange method
Vibration Class : V15	

Servomotor Model	SGMCS-02B□C			SGMCS-05B□C			SGMCS-07B□C			SGMCS-04C□C		
	02	05	07	04	10	14	08	17	25	16	35	
Rated Output*1	W											
Rated Torque*1, *2	N·m											
Instantaneous Peak Torque*1	N·m											
Stall Torque*1 (60 min ⁻¹)	N·m											
Rated Current*1	Arms											
Instantaneous Max. Current*1	Arms											
Rated Speed*1	200			200			200			150		
Max. Speed*1	500			500			500			500		
Torque Constant	N·m/Arms			N·m/Arms			N·m/Arms			N·m/Arms		
Rotor Moment of Inertia	kg·m ² ×10 ⁻⁴											
Rated Power Rate*1	kW/s											
Rated Angular Acceleration*1	rad/s ²											
Absolute Accuracy	second			second			second			second		
Repeatability	second			second			second			second		

*1 : These items and torque-motor speed characteristics quoted in combination with a SERVOPACK are at an armature winding temperature of 100°C. Other values quoted at 20°C.

*2 : Rated torques are continuous allowable torque values at 40°C with a steel heat sink attached.

Heat sink: SGMCS-02B: 350 mm × 350 mm × 12 mm SGMCS-05B: 450 mm × 450 mm × 12 mm
 SGMCS-07B: 550 mm × 550 mm × 12 mm SGMCS-04C: 650 mm × 650 mm × 12 mm

Torque-Motor Speed Characteristics

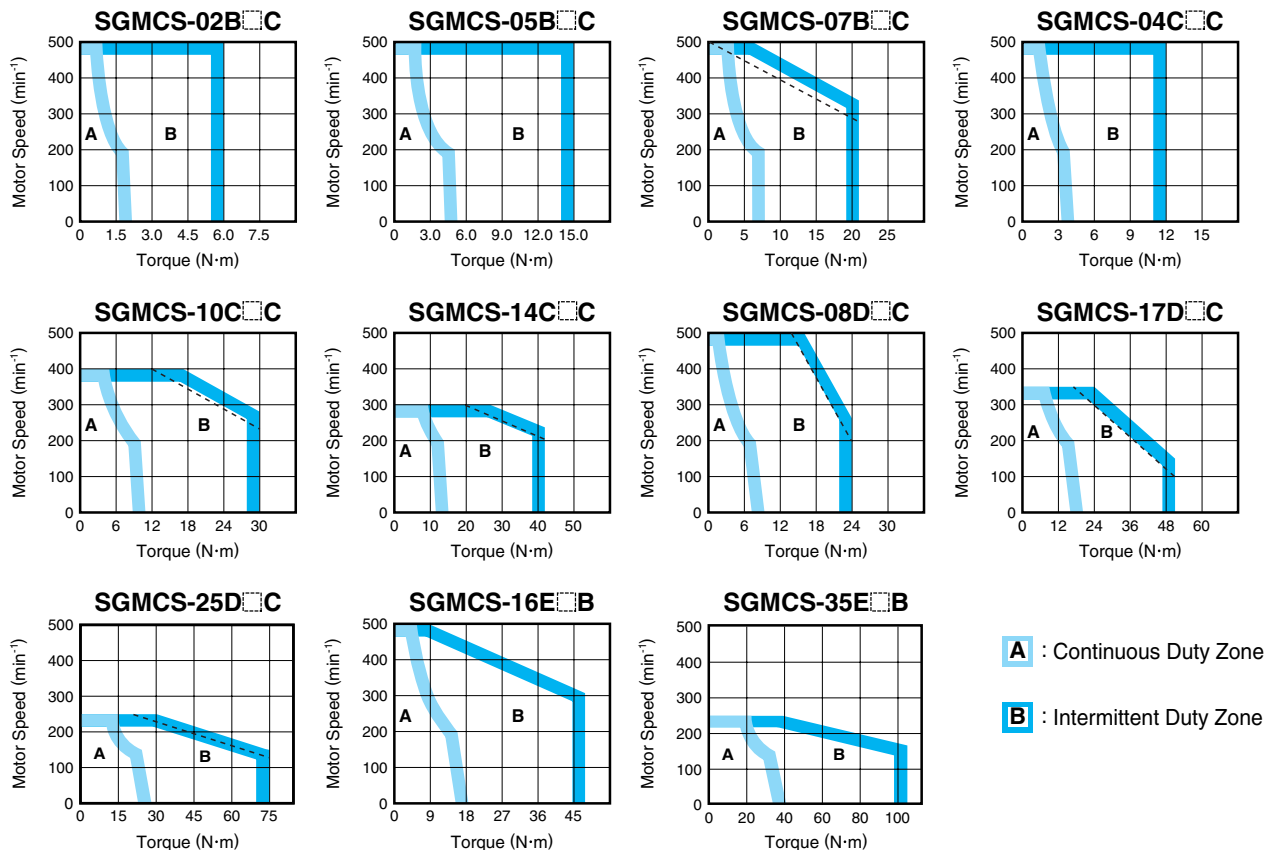

Note : The dotted line of intermittent duty zone indicates the characteristics when a servomotor runs in combination with a SERVOPACK for 100 VAC (only for Σ -III series).

Servomotors (Small Capacity)

External Dimensions Units: mm Rotating part: Non-rotating part:

SGMCS-02B□C11

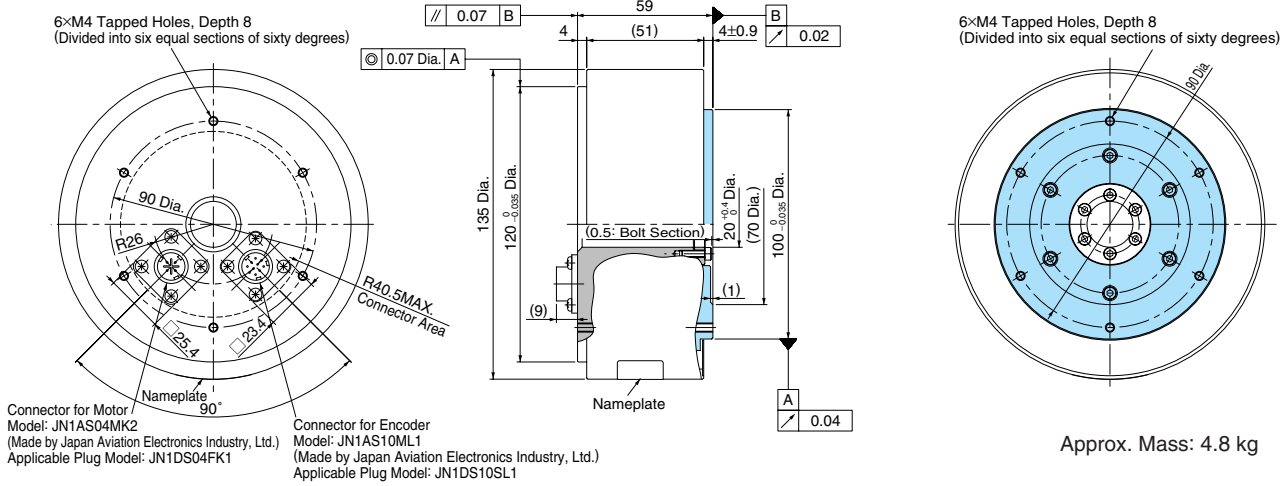

SGMCS-05B□C11

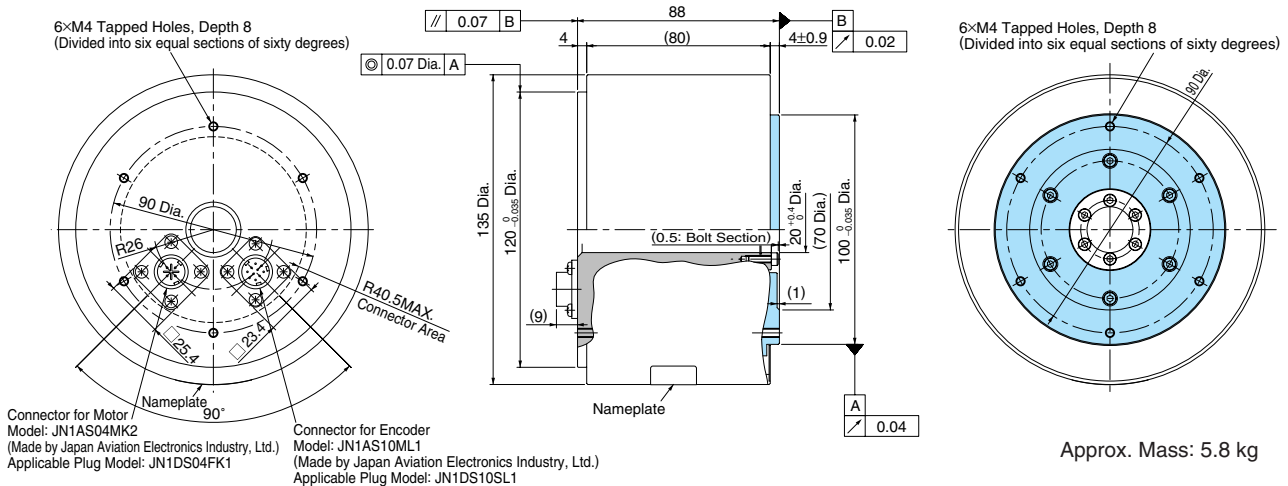

SGMCS-07B□C11

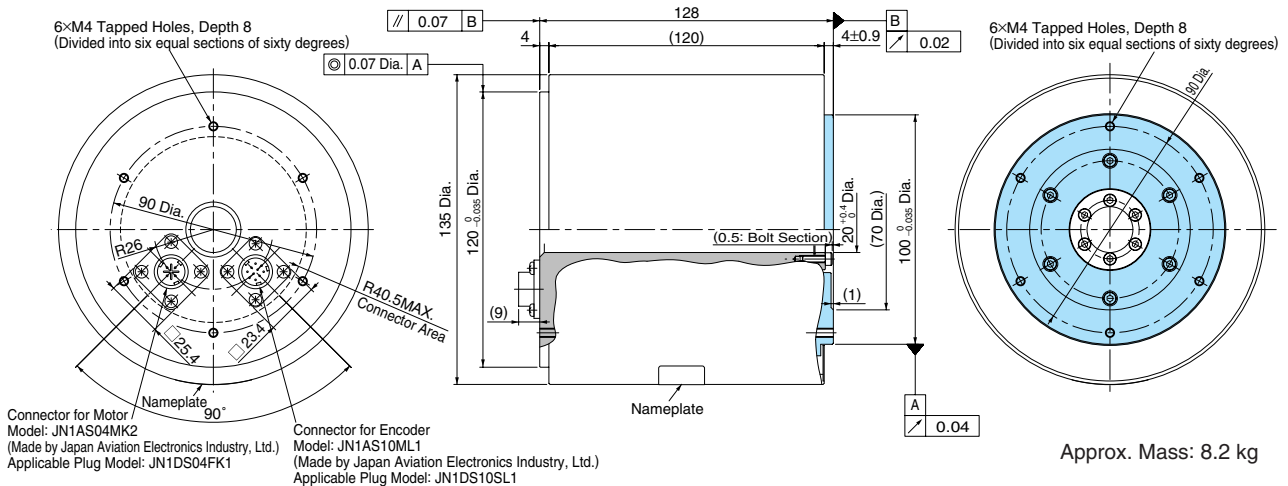

SGMCS-02B \square C41

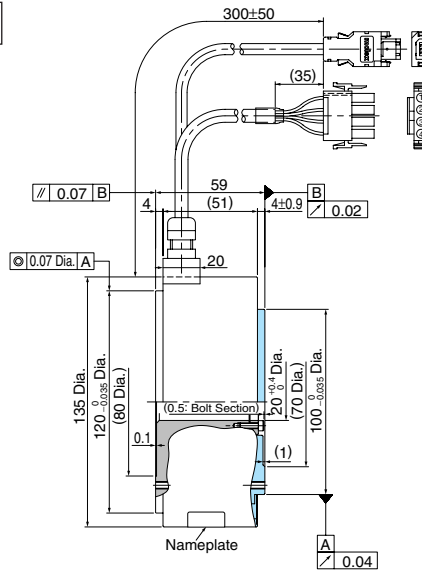
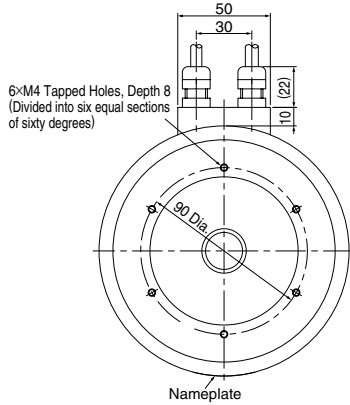

- Plug Model : 55102-0600 (Made by Molex Japan Co., Ltd.)
Applicable Plug Model: 54280-0600
- Model
- Plug : 350779-1 (Made by Tyco Electronics AMP K.K.)
- Pin : 350561-3 or 350690-3 (No.1 to 3)
- Ground Pin: 350654-1 or 350669-1 (No.4)
Applicable Plug Model
- Cap : 350780-1
- Socket : 350570-3 or 350689-3

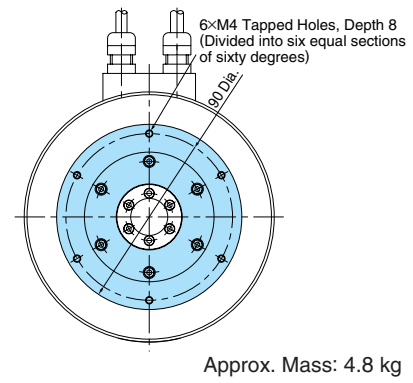

SGMCS-05B \square C41

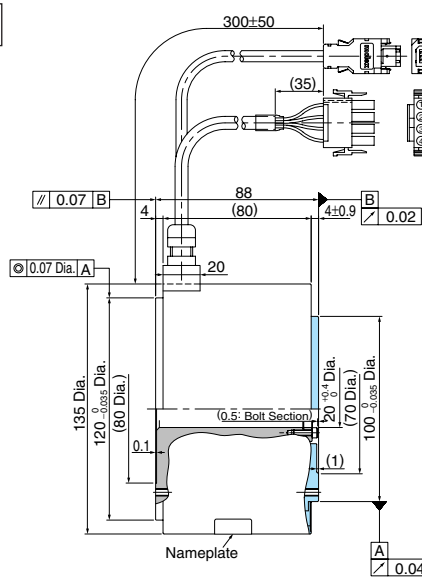
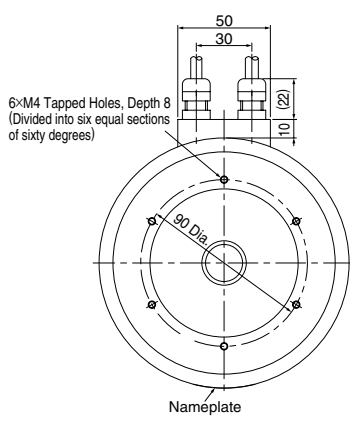

- Plug Model : 55102-0600 (Made by Molex Japan Co., Ltd.)
Applicable Plug Model: 54280-0600
- Model
- Plug : 350779-1 (Made by Tyco Electronics AMP K.K.)
- Pin : 350561-3 or 350690-3 (No.1 to 3)
- Ground Pin: 350654-1 or 350669-1 (No.4)
Applicable Plug Model
- Cap : 350780-1
- Socket : 350570-3 or 350689-3

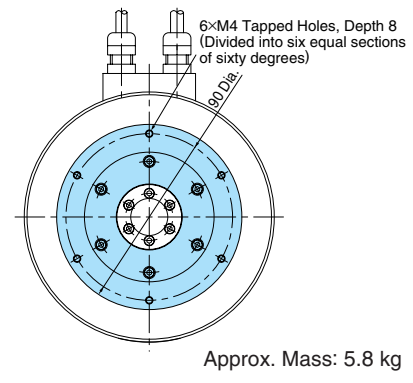

SGMCS-07B \square C41

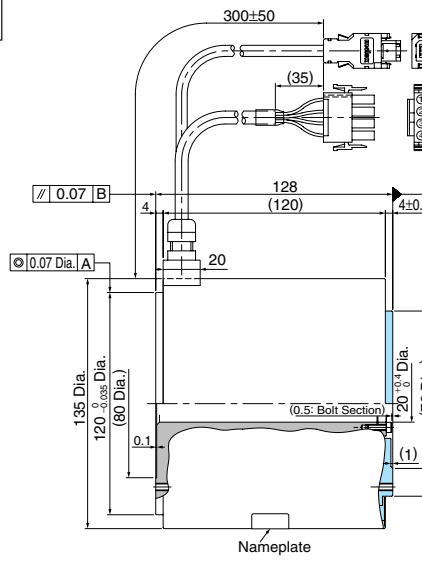
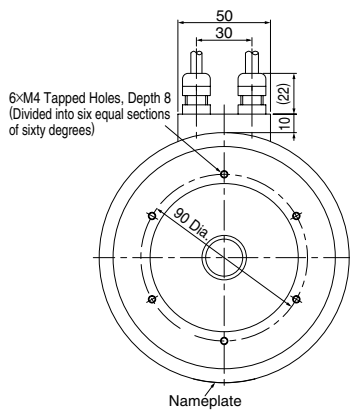

- Plug Model : 55102-0600 (Made by Molex Japan Co., Ltd.)
Applicable Plug Model: 54280-0600
- Model
- Plug : 350779-1 (Made by Tyco Electronics AMP K.K.)
- Pin : 350561-3 or 350690-3 (No.1 to 3)
- Ground Pin: 350654-1 or 350669-1 (No.4)
Applicable Plug Model
- Cap : 350780-1
- Socket : 350570-3 or 350689-3

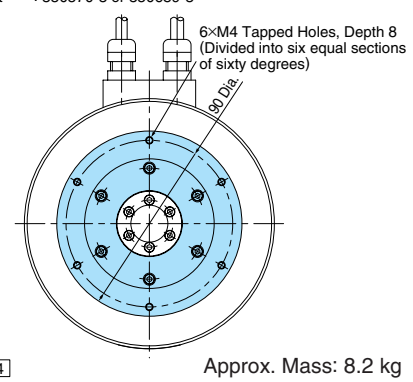

Servomotors (Small Capacity)

Servomotors (Small Capacity)

External Dimensions Units: mm Rotating part: Non-rotating part:

SGMCS-04C C11

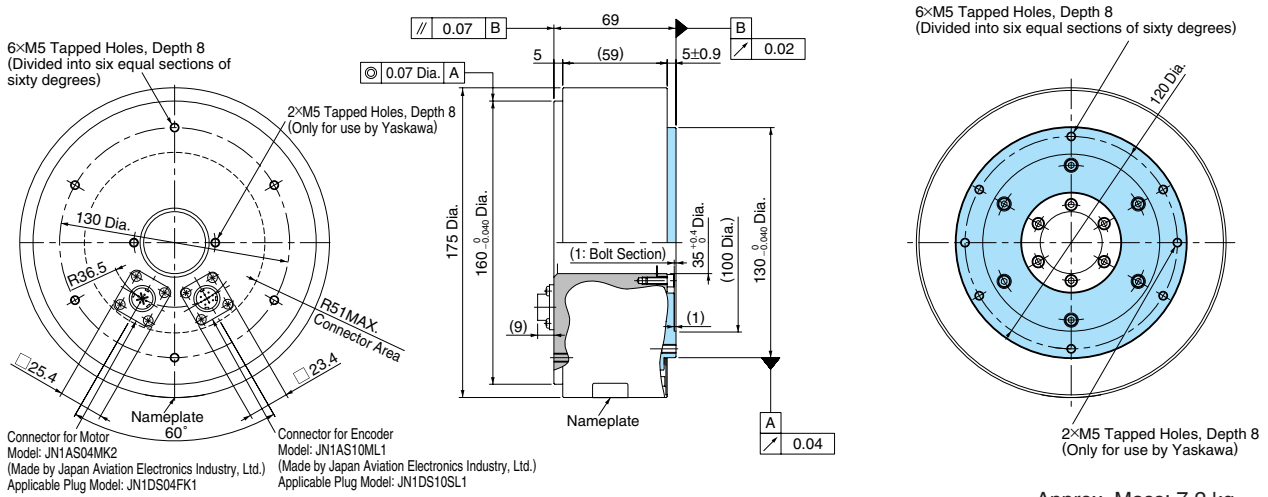

SGMCS-10C C11

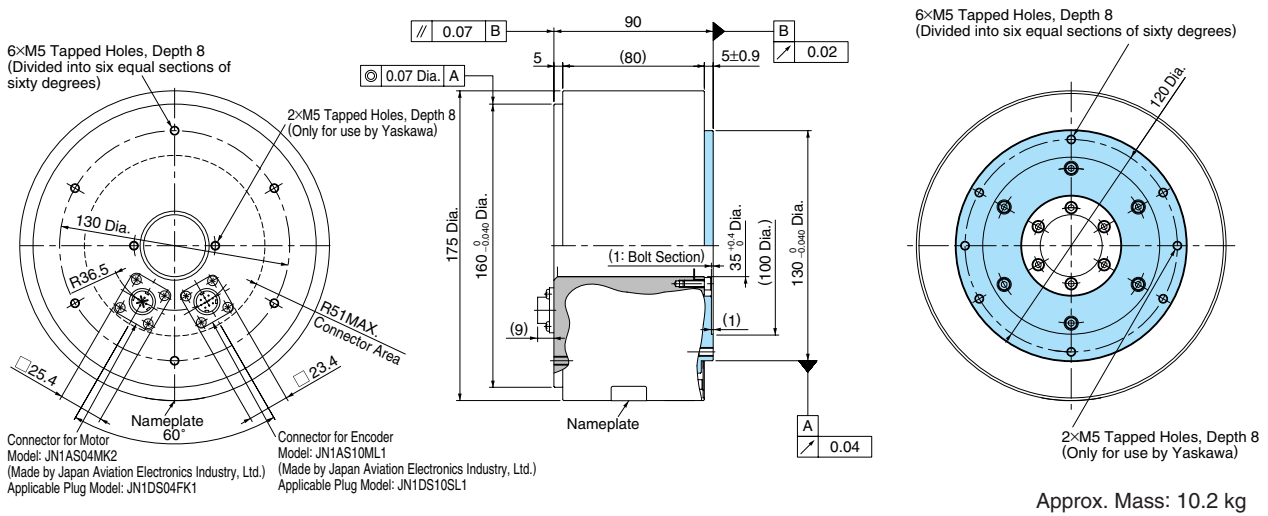

SGMCS-14C C11

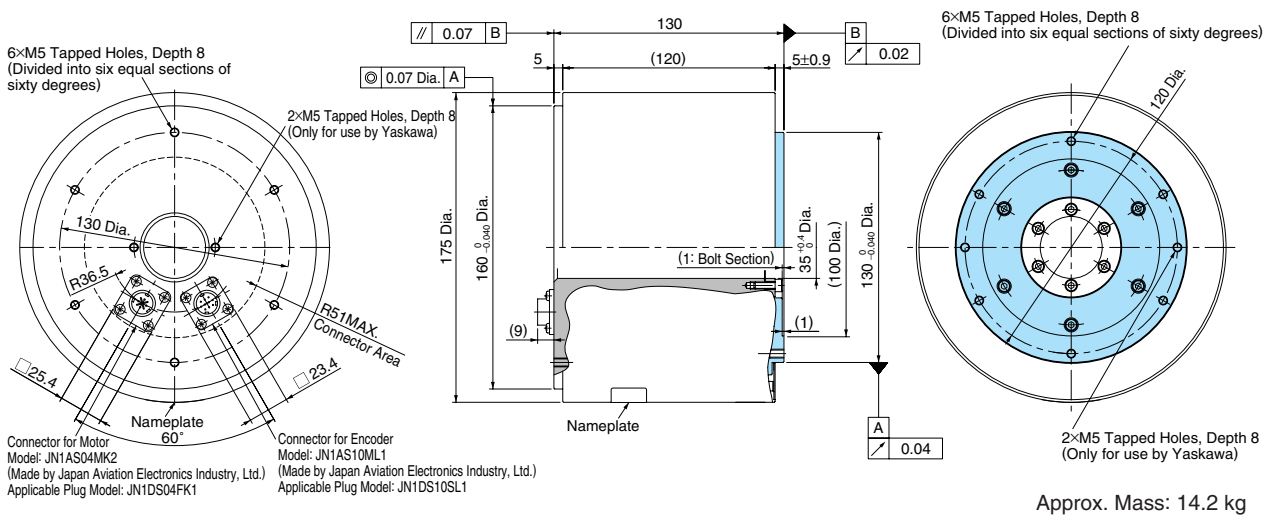

SGMCS-04C C41

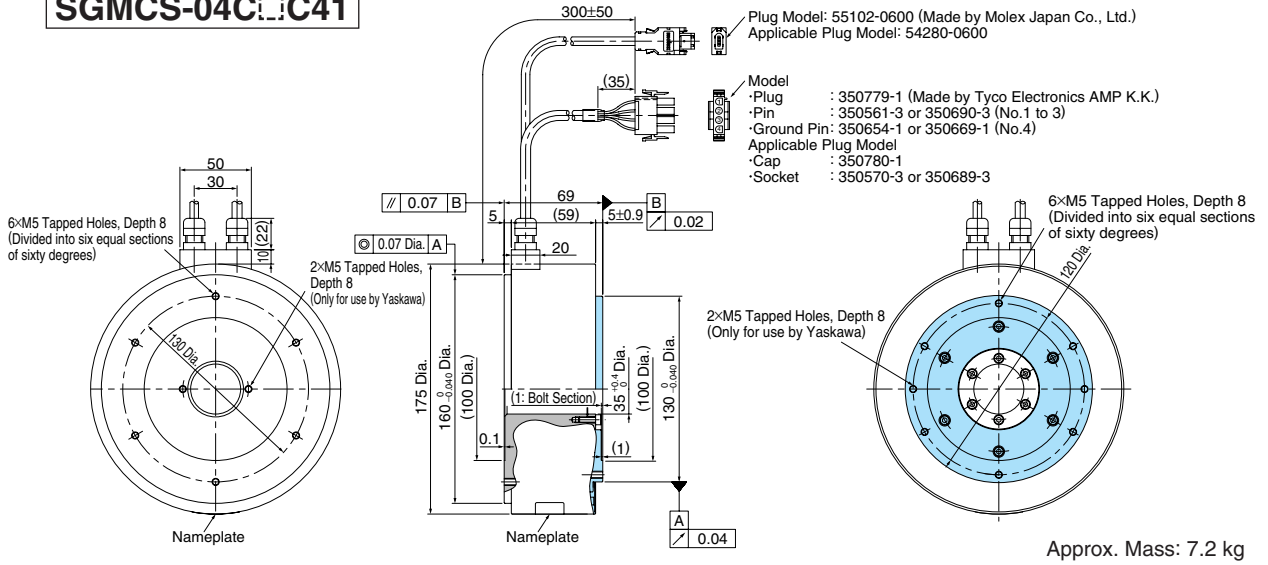

SGMCS-10C C41

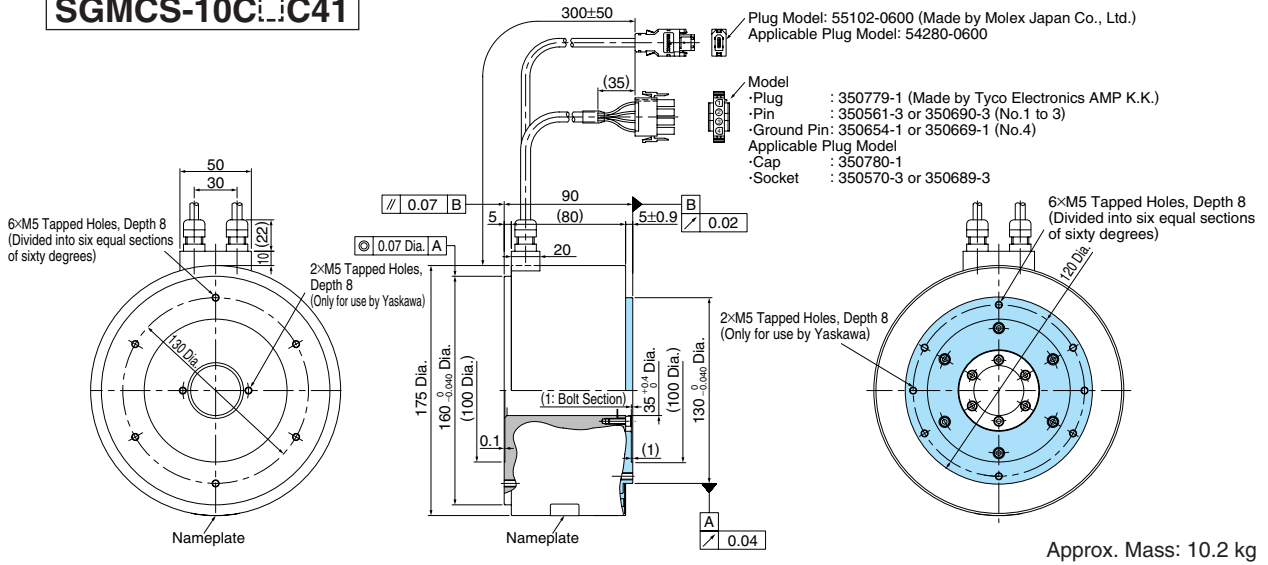

SGMCS-14C C41

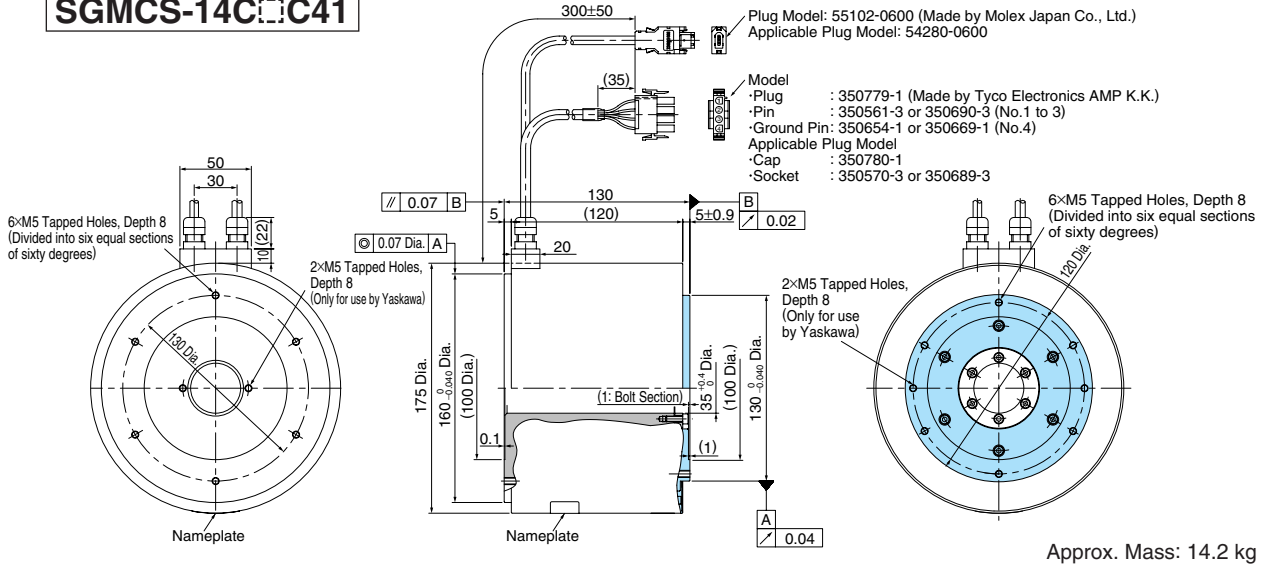

Servomotors (Small Capacity)

External Dimensions Units: mm Rotating part: Non-rotating part:

SGMCS-08D□C11

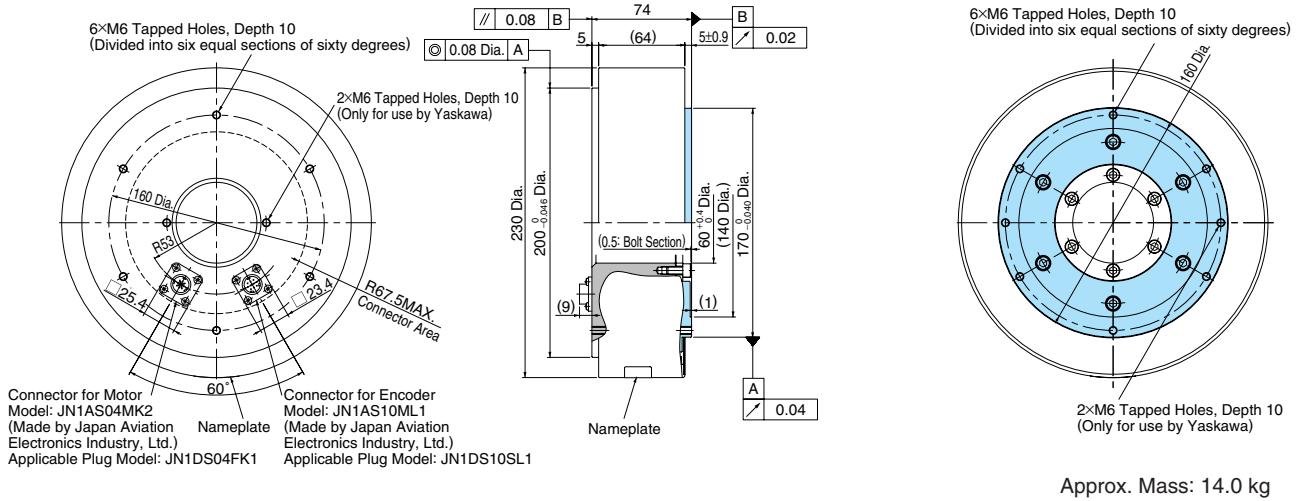

SGMCS-17D□C11

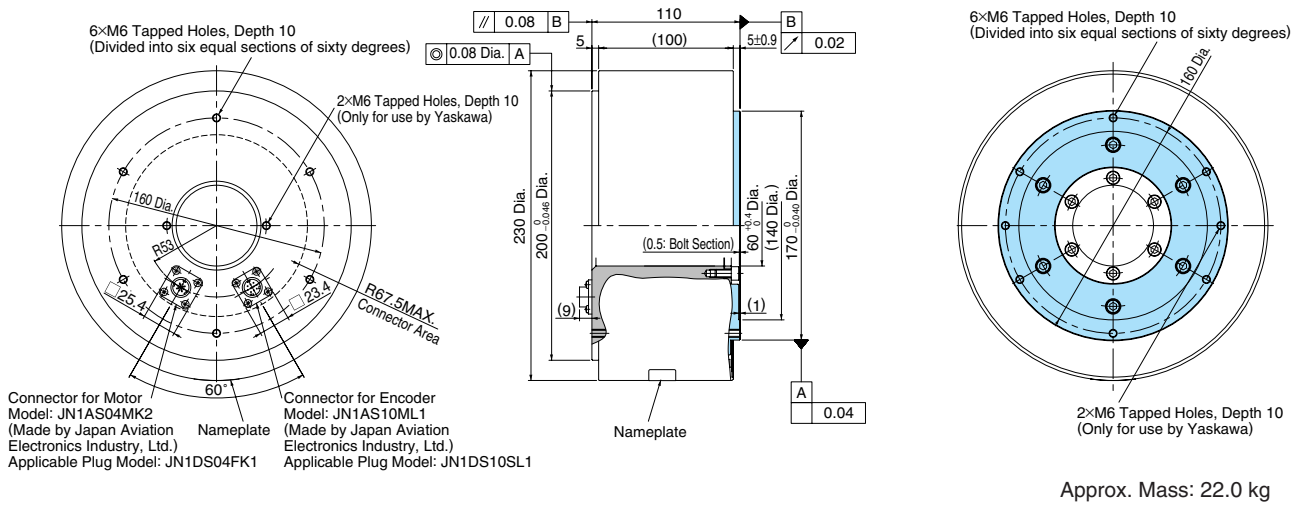

SGMCS-25D□C11

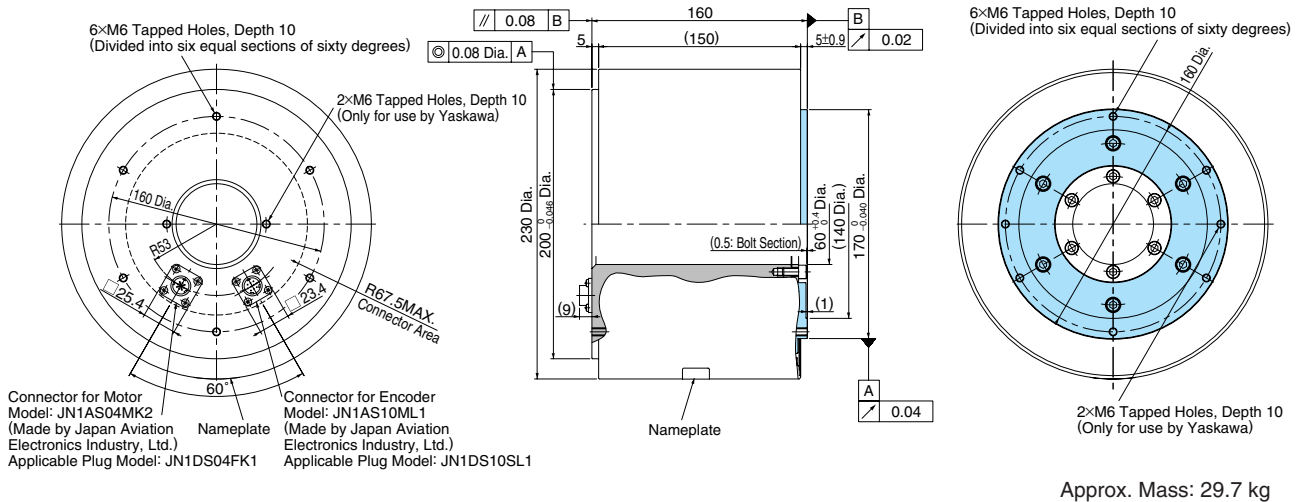

SGMCS-08D Σ C41

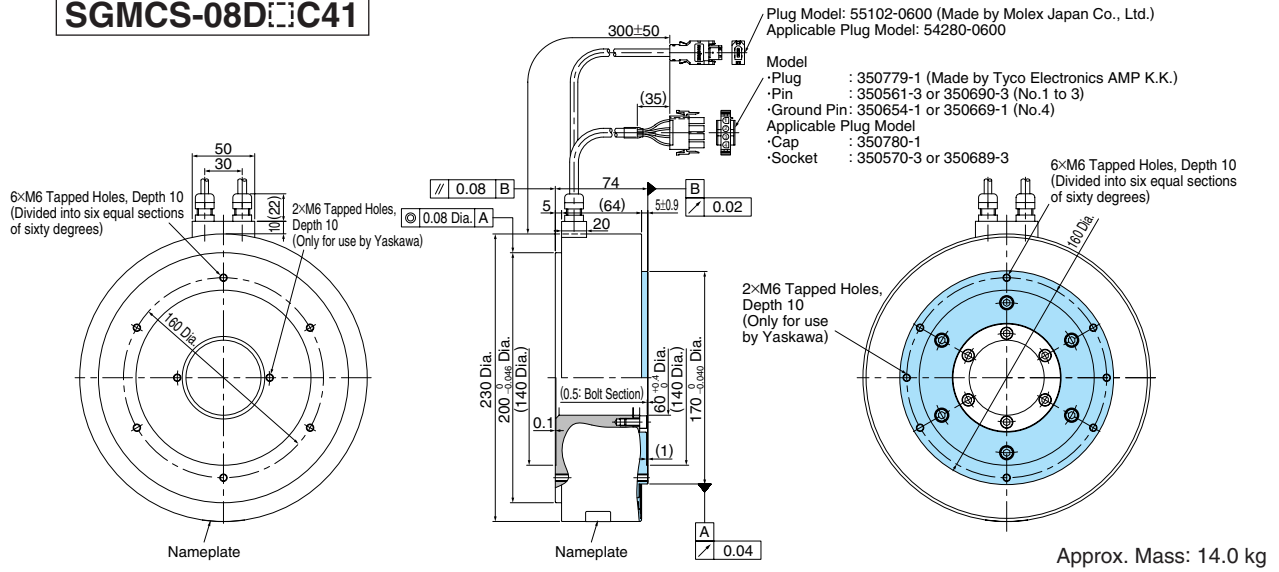

SGMCS-17D Σ C41

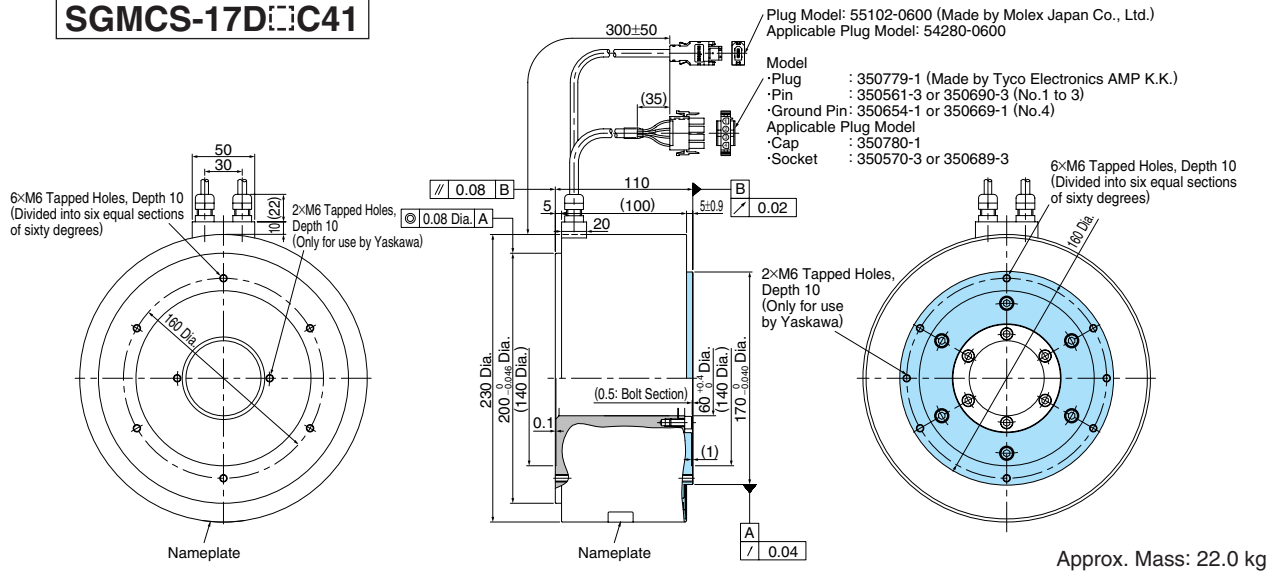

SGMCS-25D Σ C41

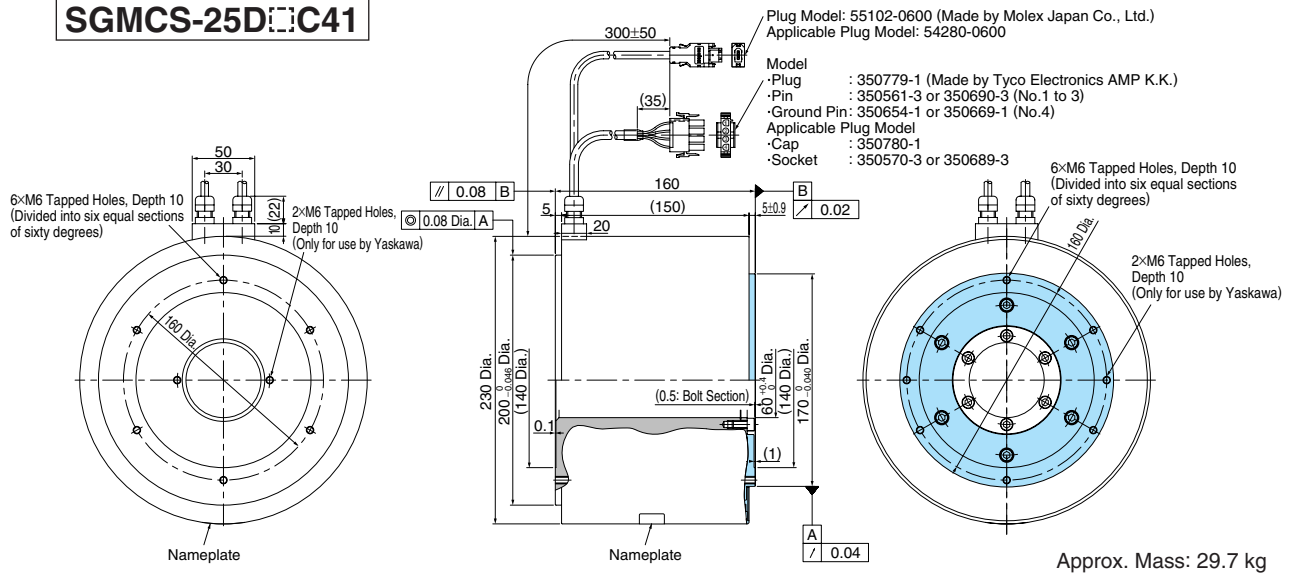

Servomotors (Small Capacity)

External Dimensions Units: mm

Rotating part: Non-rotating part:

SGMCS-16E□B11

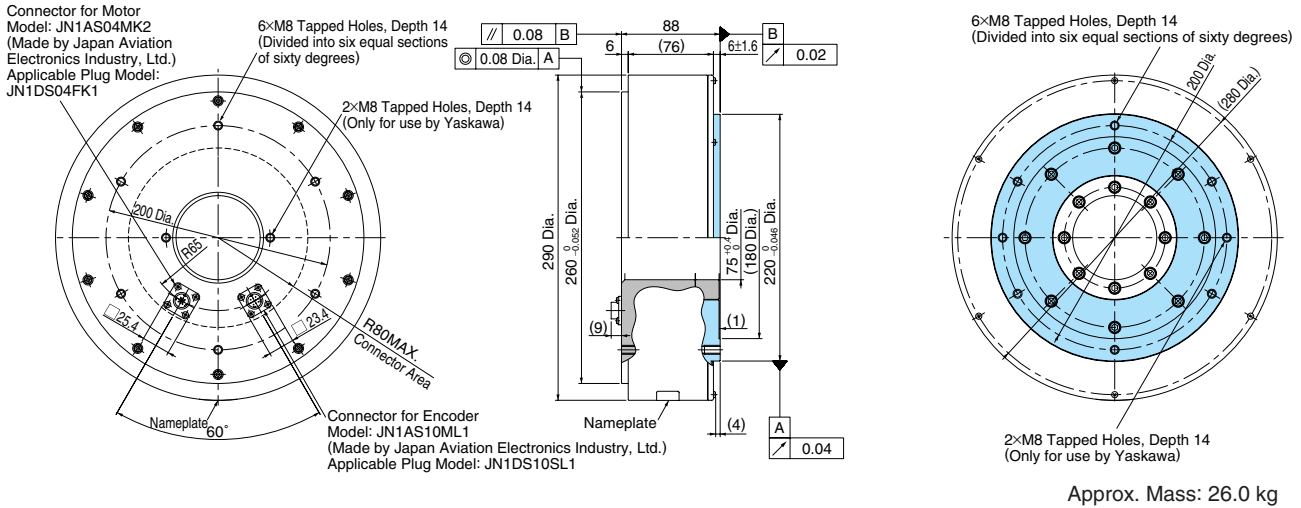

SGMCS-35E□B11

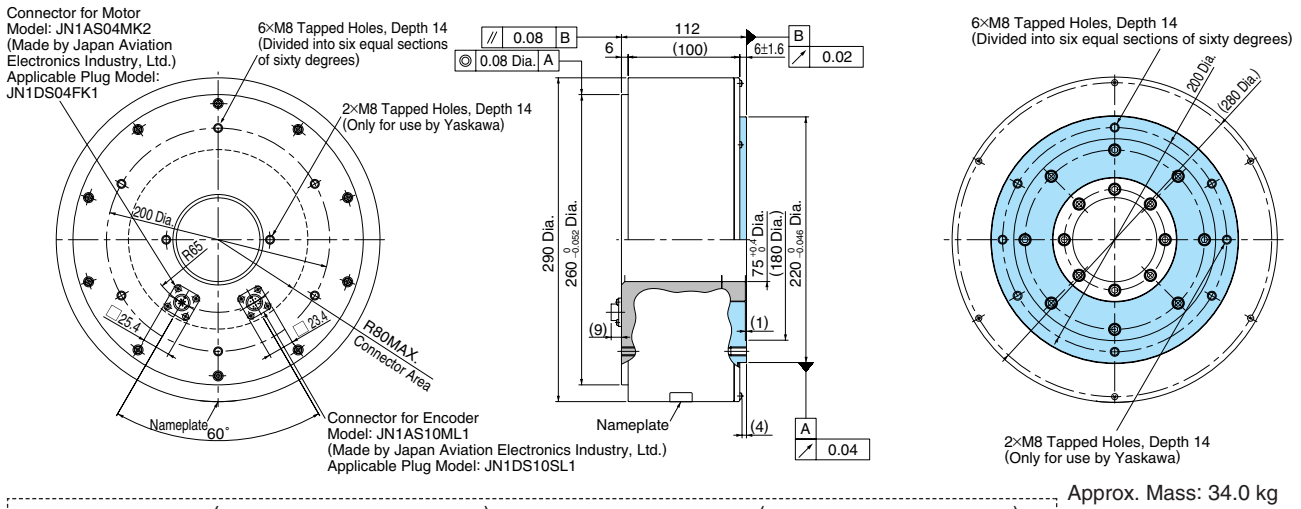

Motor connector (for small-capacity series)

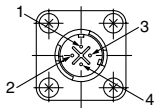

1	Phase U	Red
2	Phase V	White
3	Phase W	Blue
4	FG (Frame Ground)	Green (Yellow)

Encoder connector (for small-capacity series)

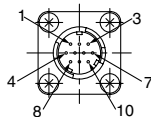

1	PS	Light Blue
2	/PS	Light Blue/White
3	—	—
4	PG5V	Red
5	—	—
6	—	—
7	FG (Frame Ground)	Shield
8	—	—
9	PG0V	Black
10	—	—

SGMCS-16E□B41

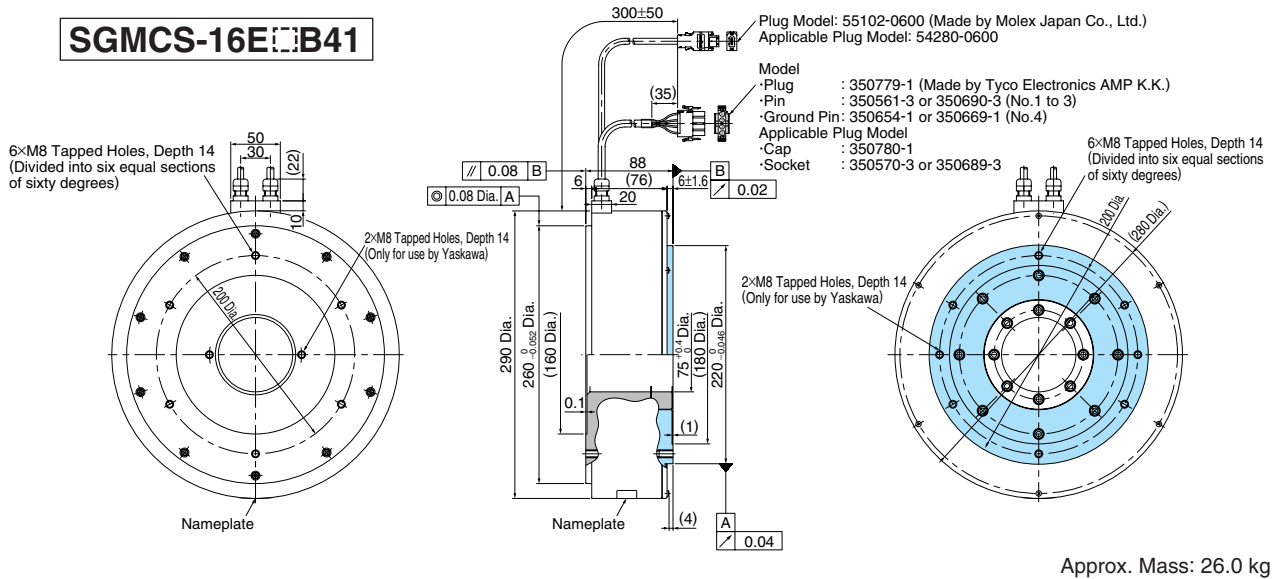

SGMCS-35E□B41

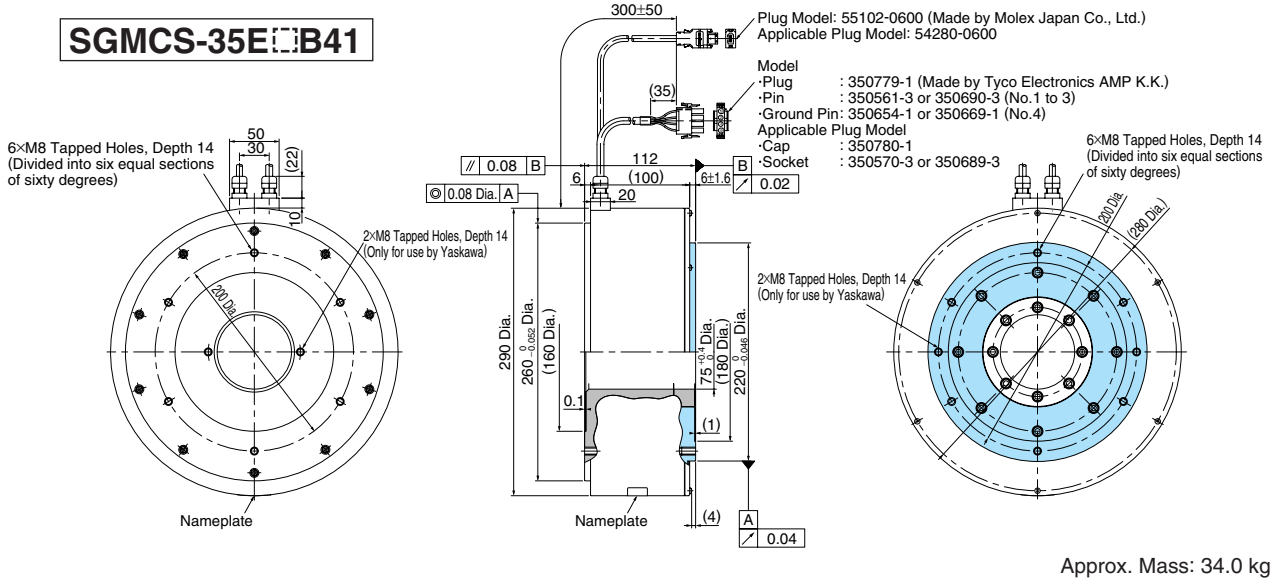

Motor connector (for small-capacity series)

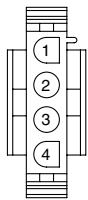

1	Phase U	Red
2	Phase V	White
3	Phase W	Blue
4	FG (Frame Ground)	Green (Yellow)

Encoder connector (for small-capacity series)

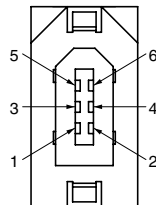

1	PG5V	Red
2	PG0V	Black
3	—	—
4	—	—
5	PS	Light Blue
6	/PS	Light Blue/White
Connector Case	FG (Frame Ground)	Shield

Load Capacity

The following figures show the load capacity during motor operation. Design the mechanical system so thrust and moment loads applied to the servomotor shaft end during operation falls within the ranges shown in the table below.

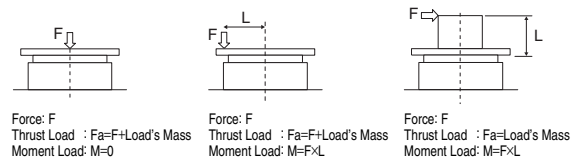

Servomotor Model SGMCS-□□	02B□C	05B□C	07B□C	04C□C	10C□C	14C□C	08D□C	17D□C	25D□C	16E□B	35E□B
Allowable Thrust Load Fa N	1500			3300			4000			11000	
Allowable Moment Load M N·m	40	50	64	70	75	90	93	103	135	250	320

Servomotors (Medium Capacity)

Ratings and Specifications

Time Rating	: Continuous	Ambient Temperature	: 0 to +40°C
Thermal Class	: F	Ambient Humidity	: 20% to 80% (no condensation)
Withstand Voltage	: 1500 VAC for one minute	Excitation	: Permanent magnet
Insulation Resistance	: 500 VDC, 10 M Ω min.	Drive Method	: Direct drive
Enclosure	: Totally-enclosed, self-cooled	Mounting	: Flange method
Vibration Class	: V15		

Servomotor Model		SGMCS-□□□□					
		45M	80M	1AM	80N	1EN	2ZN
Rated Output*	W	707	1260	1730	1260	2360	3140
Rated Torque*	N·m	45	80	110	80	150	200
Instantaneous Peak Torque*	N·m	135	240	330	240	450	600
Stall Torque*	N·m	45	80	110	80	150	200
Rated Current*	Arms	5.80	9.74	13.4	9.35	17.4	18.9
Instantaneous Max. Current*	Arms	17	28	42	28	56	56
Rated Speed*	min ⁻¹	150	150	150	150	150	150
Max. Speed*	min ⁻¹	300	300	300	300	250	250
Torque Constant	N·m/Arms	8.39	8.91	8.45	9.08	9.05	11.5
Rotor Moment of Inertia	kg·m ² ×10 ⁻⁴	388	627	865	1360	2470	3060
Rated Power Rate*	kW/s	52.2	102	140	47.1	91.1	131
Rated Angular Acceleration	Rad/s ²	1160	1280	1270	588	607	654

* : These items and torque-motor speed characteristics quoted in combination with a SERVOPACK are at an armature winding temperature of 20°C. The values listed here are representative of the values obtained when a steel-plate heat sink (750 mm × 750 mm × 45 mm) is used for cooling.

Torque-Motor Speed Characteristics

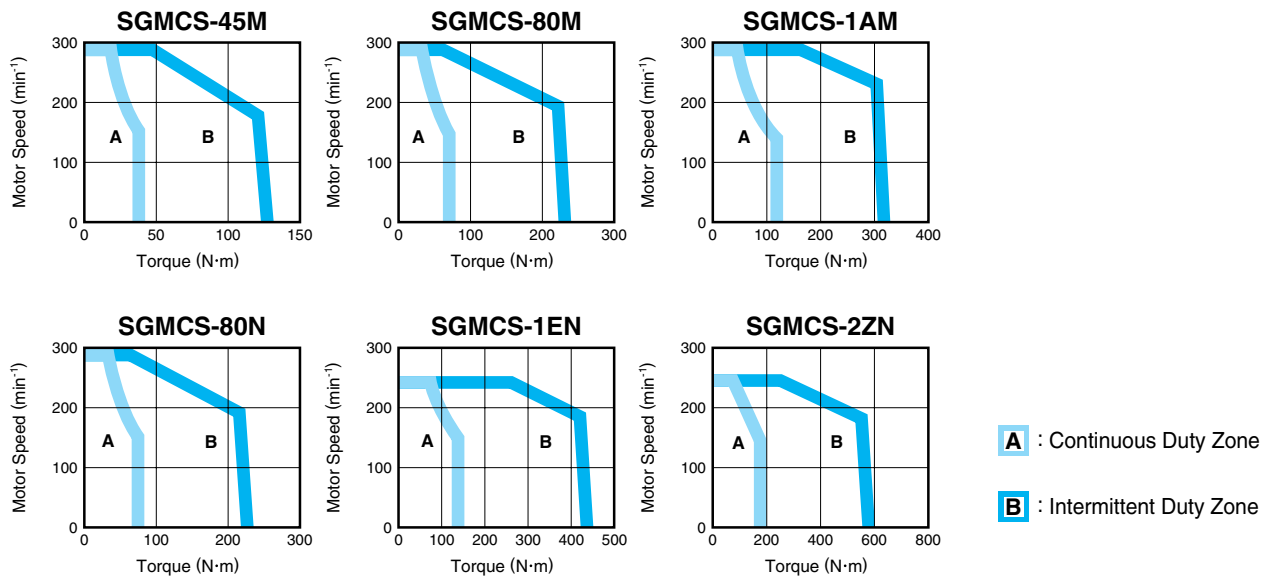

Load Capacity

The following figures show the load capacity during motor operation. Design the mechanical system so thrust and moment loads applied to the servomotor shaft end during operation falls within the ranges shown in the table below.

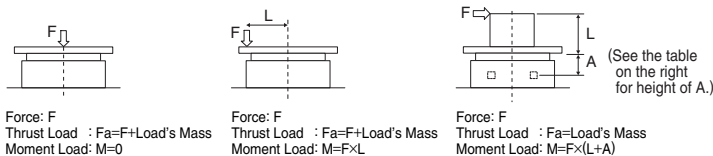

Servomotor Model	45M	80M	1AM	80N	1EN	2ZN
SGMCS-□□□□						
Dimension A mm		33			37.5	
Allowable Thrust Load F_a N		9000			16000	
Allowable Moment Load M N·m		180			350	

● External Dimensions Units: mm Rotating part:

SGMCS-45M \square A11

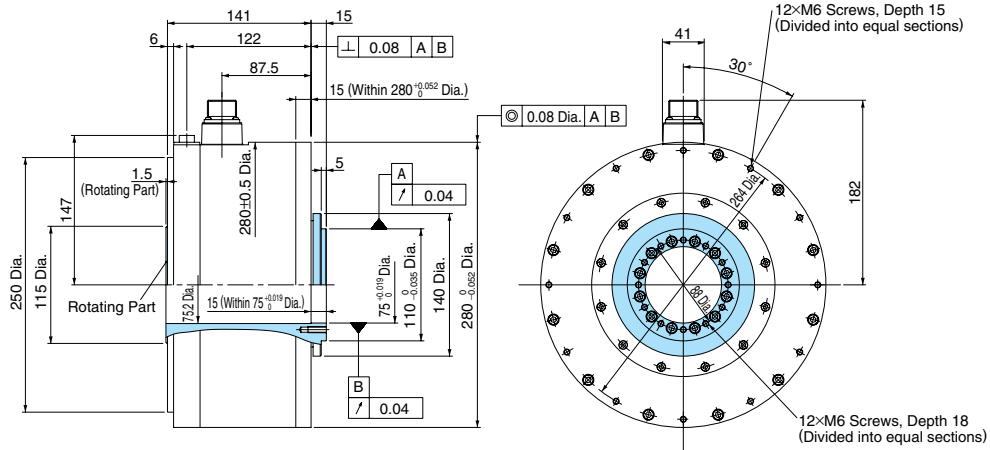

Approx. Mass: 38 kg

SGMCS-80M \square A11

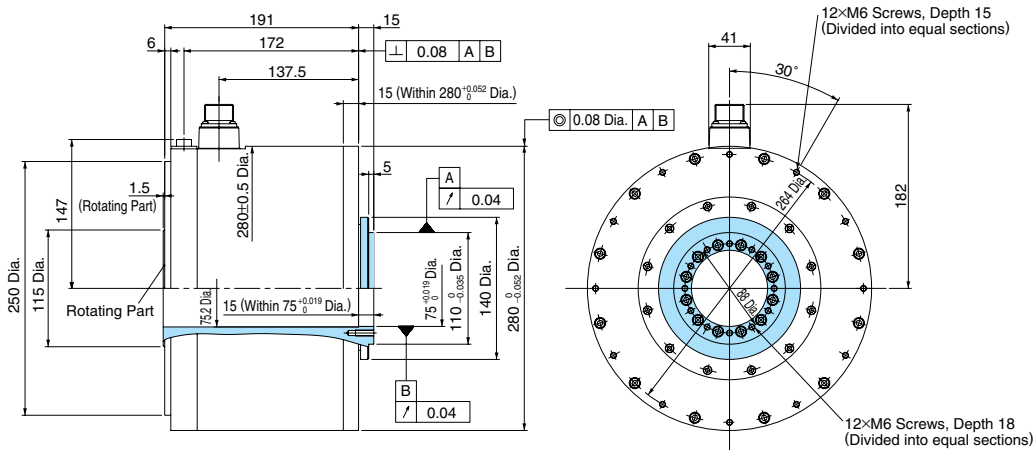

Approx. Mass: 45 kg

SGMCS-1AM \square A11

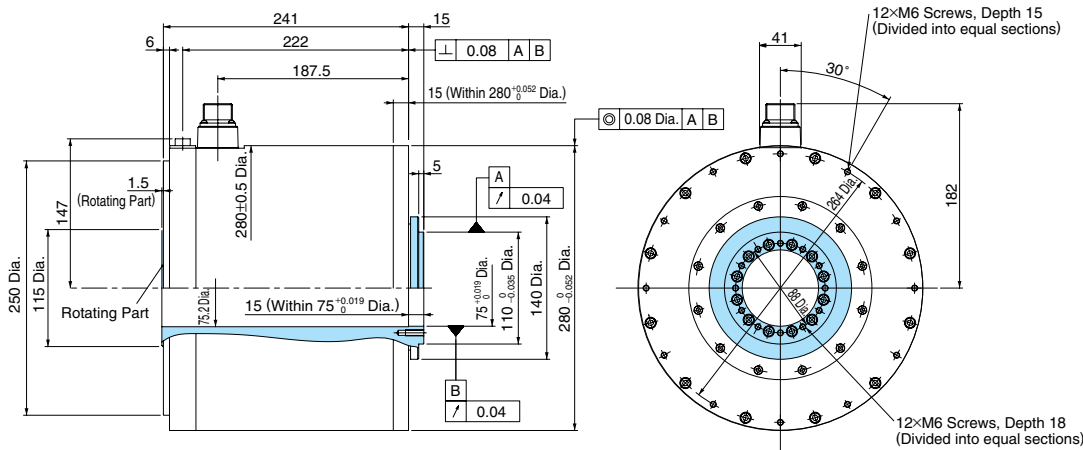

Approx. Mass: 51 kg

● External Dimensions Units: mm Rotating part:

SGMCS-45M \square A31

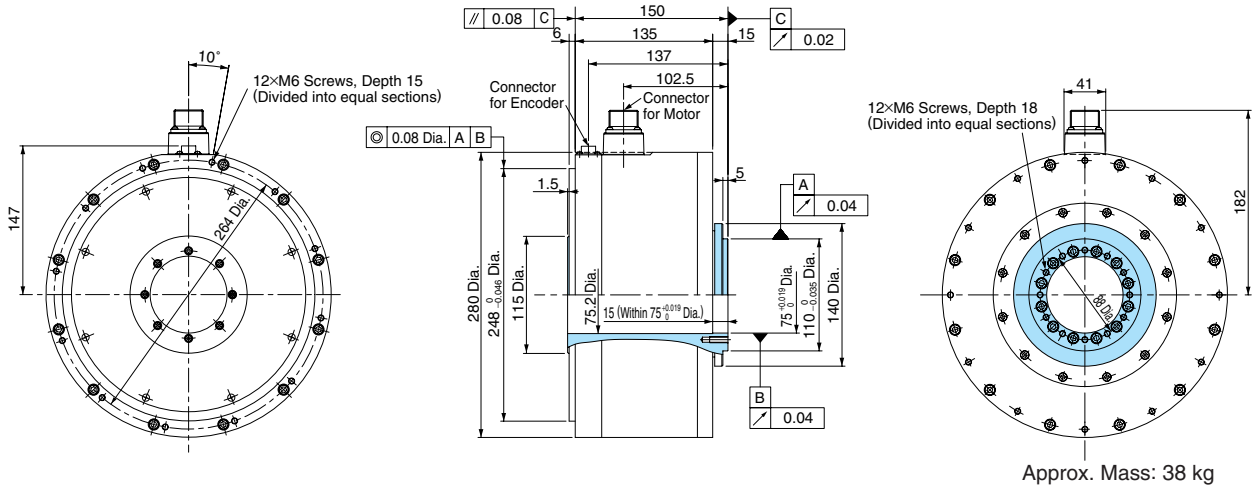

SGMCS-80M \square A31

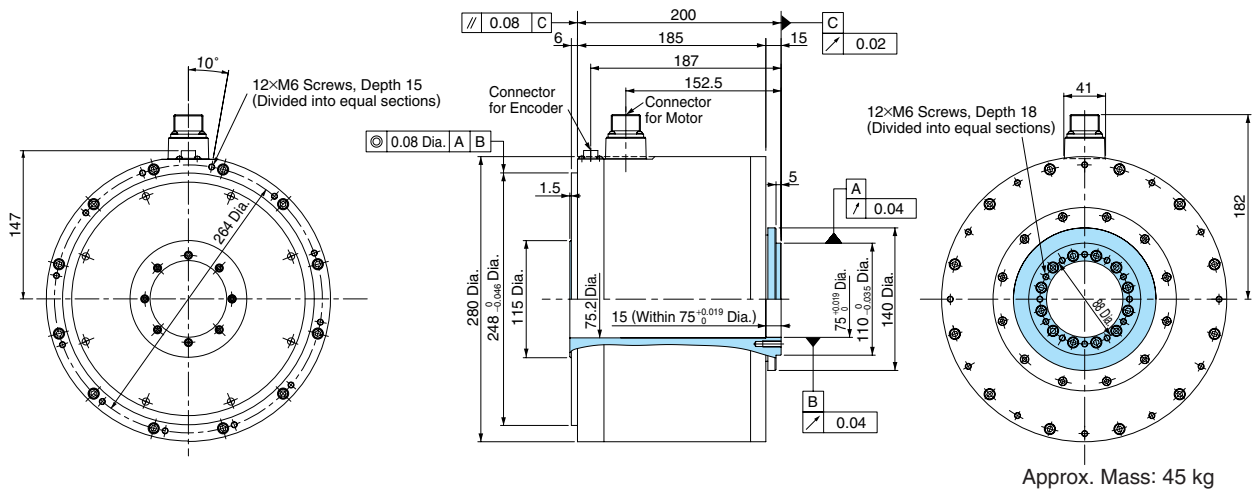

SGMCS-1AM \square A31

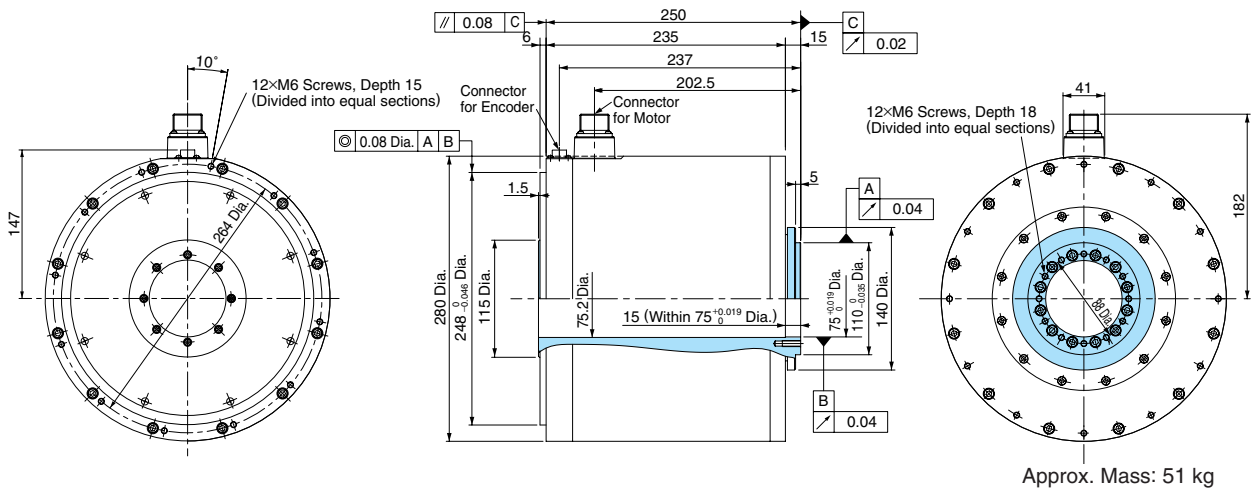

SGMCS-80N Σ A11

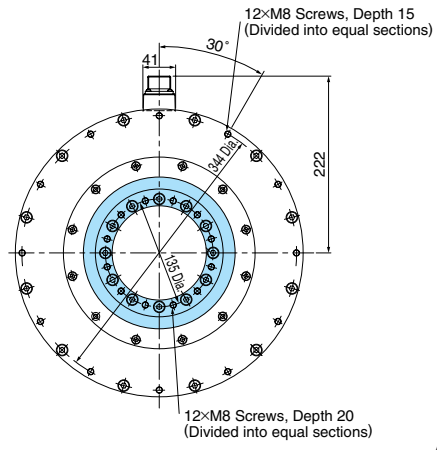
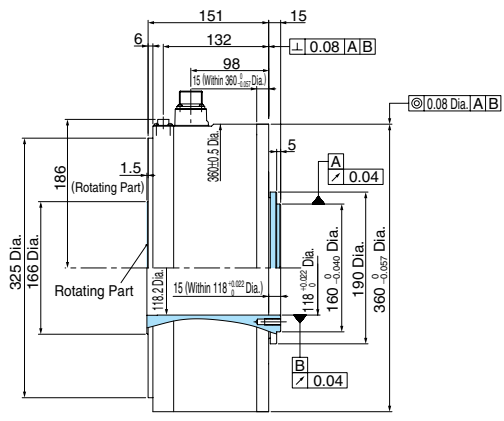

Approx. Mass: 50 kg

SGMCS-1EN Σ A11

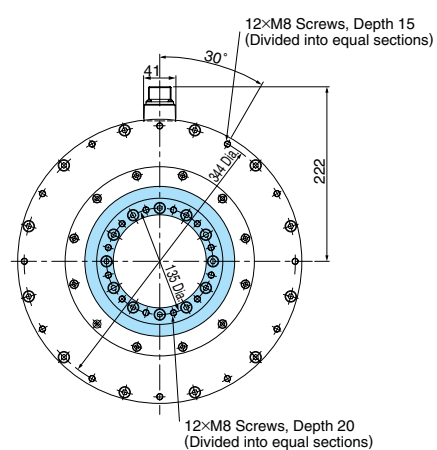
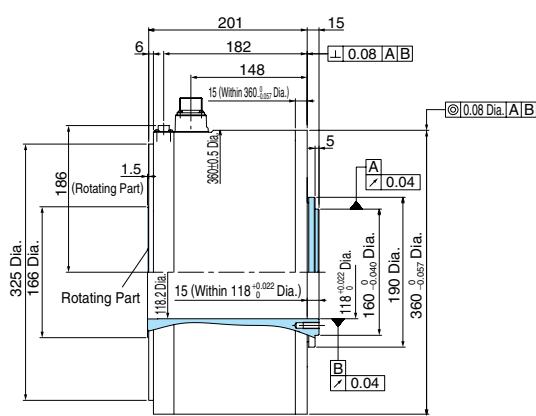

Approx. Mass: 68 kg

SGMCS-2ZN Σ A11

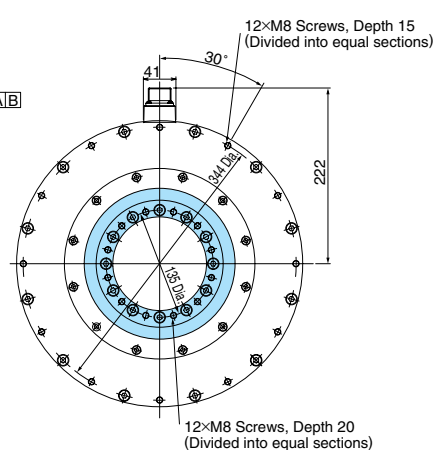
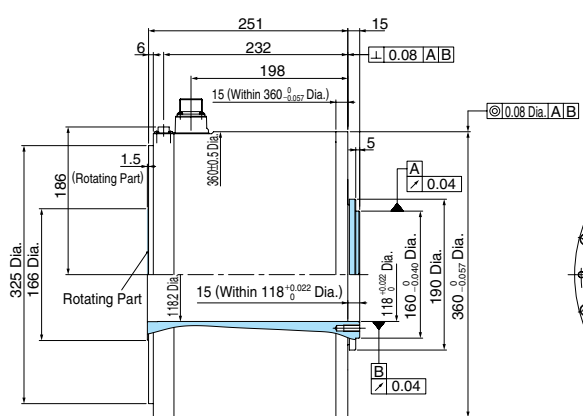

Approx. Mass: 86 kg

Servomotors (Medium Capacity)

External Dimensions Units: mm Rotating part:

SGMCS-80N \square A31

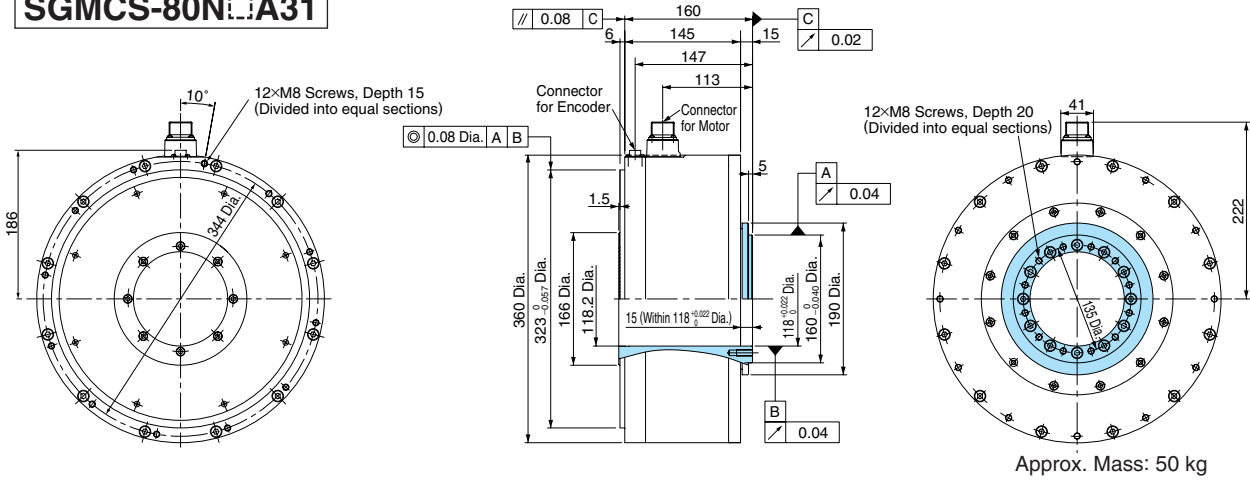

Approx. Mass: 50 kg

SGMCS-1EN \square A31

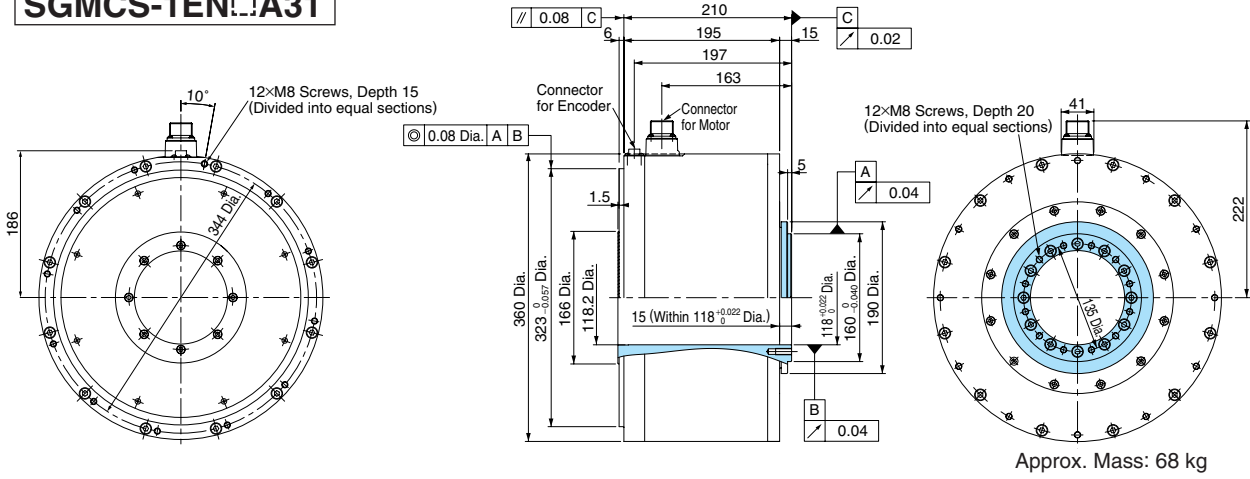

Approx. Mass: 68 kg

SGMCS-2ZN \square A31

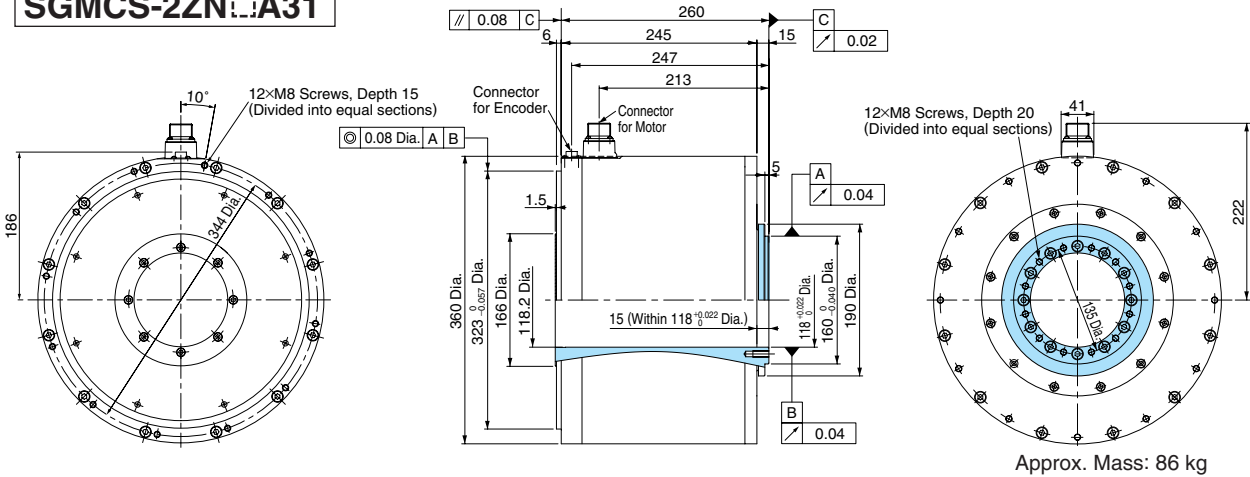

Approx. Mass: 86 kg

Motor connector (for medium-capacity series)

Model: CE05-2A18-10PD (Made by DDK Electronics, Inc.)

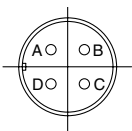

A	Phase U
B	Phase V
C	Phase W
D	FG (Frame Ground)

Encoder connector (for medium-capacity series)

Model: JN1AS10ML1 (Made by Japan Aviation Electronics Industry, Ltd.)



1	PS	7	FG (Frame Ground)
2	/PS	8	—
3	—	9	PG5V
4	PG5V	10	PG0V
5	—	—	—
6	—	—	—

SERVOPACKs

● Ratings and Specifications

SGDS

SERVOPACK MODEL		SGDS- 	02 							
Applicable Servomotor Model		SGMCS- 	02B, 05B, 07B	04C, 10C, 14C, 08D, 17D, 25D	16E, 35E	45M	80M, 80N	1AM	1EN, 2ZN	
Max. Applicable Motor Capacity		kW	0.2	0.4	0.75	1.0	1.5	2.0	3.0	
100 V	Continuous Output Current	Arms	2.1	2.8	—	—	—	—	—	
	Max. Output Current	Arms	6.5	8.5	—	—	—	—	—	
200 V	Continuous Output Current	Arms	2.1	2.8	5.5	7.6	11.6	18.5	18.9	
	Max. Output Current	Arms	6.5	8.5	16.9	17.0	28.0	42.0	56.0	
Basic Specifications	Input Power Supply	SERVOPACK Capacity Range	Single-phase 100 VAC/Single-phase 200 VAC		Single-phase 200 VAC	Three-phase 200 VAC				
		Main Circuit	Three-phase (or Single-phase)	200 to 230 VAC +10 to -15%, 50/60 Hz						
			Single-phase	100 to 115 VAC +10 to -15%, 50/60 Hz						
	Control Circuit	Single-phase	200 to 230 VAC +10 to -15%, 50/60 Hz							
		Single-phase	100 to 115 VAC +10 to -15%, 50/60 Hz							
	Control Method	Single-phase or three-phase full-wave rectification (single-phase voltage doubler rectifier at 100V), IGBT, PWM control, sine-wave power drive system								
	Feedback	17-bit serial encoder (incremental/absolute), 20-bit serial encoder (incremental/absolute)								
	Operating Conditions	Ambient/Storage Temperature	0 to +55°C / -20 to +85°C							
		Ambient/Storage Humidity	90% RH or less (with no condensation)							
		Vibration/Shock Resistance	4.9 m/s ² / 19.6 m/s ²							
Configuration	Base mounted (Rack mounted available as an option.)									
Performance	Speed Control Range	1: 5000 (The lowest speed of the speed control range is the speed at which the servomotor will not stop with a rated torque load.)								
	Speed Regulation	Load Regulation	0% to 100% load: ±0.01% max. (at rated speed)							
		Voltage Regulation	Rated voltage ±10%: ±0.01% max. (at rated speed)							
		Temperature Regulation	25±25°C: ±0.1% max. (at rated speed)							
	Frequency Characteristics	600 Hz (at J _L = J _M)								
	Torque Control Tolerance (Repeatability)	±1%								
Soft Start Time Setting	0 to 10 s (Can be set individually for acceleration and deceleration.)									
Torque Control Mode	Input Signals	Reference Voltage	±3 VDC (Variable setting range: ±1 to ±10 VDC) at rated torque (positive torque reference with positive reference), input voltage: ±12 V max.							
		Input Impedance	Approx. 14kΩ or more							
		Circuit Time Constant	30 μs							
Speed Control Mode	Performance	Soft Start Time Setting	0 to 10 s (Can be set individually for acceleration and deceleration.)							
	Input Signals	Reference Voltage	±6 VDC (Variable setting range: ±2 to ±10 VDC) at rated speed (servomotor forward rotation with positive reference), input voltage: ±12 V max.							
		Input Impedance	Approx. 14kΩ or more							
		Circuit Time Constant	30 μs							
	Contact Speed Reference	Rotation Direction Selection	With P control signal							
Speed Selection	With forward/reverse current limit signal (speed 1 to 3 selection). Servomotor stops or another control method is used when both are OFF.									
Position Control Mode	Performance	Bias Setting	0 to 450 min ⁻¹ (setting resolution: 1 min ⁻¹)							
		Feed-forward Compensation	0% to 100% (setting resolution: 1%)							
		Positioning Completion Width Setting	0 to 1073741824 reference units (setting resolution: 1 reference unit)							
	Input Signals	Reference	Type	Select one signal from: Sign-pulse train, CCW+CW pulse train, and 90° phase difference 2-phase pulse (phase A + phase B).						
		Pulse	Form	Non-insulated line driver (+5V level)						
Frequency			1 Mpps max. (non-insulated line driver)							
Control Signal	CLEAR (Input pulse form is identical to photocoupler.)									
I/O Signals	Position Output	Form	Phase A, phase B, phase C: Line driver output							
		Frequency Dividing Ratio	Arbitrary dividing (16 to 262144)							
	Sequence Input Signal	Signal allocation can be modified.	Servo ON, P control (or Control Mode switching, forward/reverse motor rotation by internal speed setting, zero clamping, reference pulse inhibit), forward/reverse run prohibited (P-OT/N-OT), alarm reset, forward/reverse current limit (or internal speed selection), and gain switching							
	Sequence Output Signal	Fixed Output	Servo alarm, alarm code (3-bit output)							
Signal allocation can be modified.	Select three signals from: Positioning completed (speed coincidence), rotation detection, servo ready, current limit, speed warning, or NEAR signal.									
Built-in Functions	Analog Monitor (CN5)		Analog monitor connector built-in for monitoring speed, torque, and other reference signals. Speed : 1 V/1000 min ⁻¹ Torque : 1 V/rated torque 100% Lag pulse: 0.05 V/reference unit *Can be changed to other monitors by parameter setting.							
	Indicators (LED Display)		CHARGE, five 7-segment LEDs (built-in digital operator functions)							
	Communications	Interface	Digital operator (hand-held type)							
		Functions	Status display, parameter settings, monitor display, alarm traceback display, JOG operation, etc.							
	Dynamic Brake (DB)		Operated at main power OFF, servo alarm, servo OFF, or overtravel.							
	Regenerative Processing		External regenerative resistor				Built-in regenerative resistor			
	Overtravel Prevention (OT)		DB stop, deceleration to a stop, or coasting to a stop at P-OT or N-OT							
	Electronic Gear		0.001 ≤ B/A ≤ 1000							
	Protective Functions		Overcurrent, overvoltage, undervoltage, overload, regeneration error, main circuit sensor error, heat sink overheat, power phase loss, overflow, overspeed, encoder error, overrun protection, CPU error, parameter error, etc.							
	Others		Reverse rotation connection, origin search, automatic motor discrimination function							

Note:  in the SERVOPACK model should be F or A.
 F=Input power supply is 100 VAC. Input power supply for applicable motor is 200 VAC.
 A=Input power supply is 200 VAC.

SERVOPACKS

SERVOPACKs

● Ratings and Specifications

SGDH

SERVOPACK MODEL		SGDH-□□□	02AE	04AE	08AE	10AE	15AE	20AE	30AE	
Basic Specifications	Applicable Servomotor Model	SGMCS-□□□□	02B, 05B, 07B	04C, 10C, 14C, 08D, 17D, 25D	16E, 35E	45M	80M, 80N	1AM	1EN, 2ZN	
	Max. Applicable Servomotor Capacity	kW	0.2	0.4	0.75	1.0	1.5	2.0	3.0	
	Continuous Output Current	Arms	2.1	2.8	5.7	7.6	11.6	18.5	24.8	
	Max. Output Current	Arms	6.2	8.5	13.9	17	28	42	56	
	Input Power Supply	Main Circuit	Single-phase 200 to 230 VAC +10 to -15%, 50/60 Hz			Three-phase 200 to 230 VAC +10 to -15%, 50/60 Hz				
		Control Circuit	Single-phase 200 to 230 VAC +10 to -15%, 50/60 Hz							
	Control Method	Single-phase full-wave rectification, IGBT, PWM control, sine-wave power drive system				Three-phase full-wave rectification, IGBT, PWM control, sine-wave power drive system				
	Feedback	20-bit serial encoder (incremental/absolute)								
	Configuration	Base mounted (Rack mounted available as an option.)								
	Approx. Mass	kg	0.8	1.1	1.7	1.7	2.8	3.8	3.8	
Conditions	Ambient/Storage Temperature	0 to +55°C / -20 to +85°C								
	Ambient/Storage Humidity	90% RH or less (with no condensation)								
	Altitude	1000 m or less								
	Vibration/Shock Resistance	4.9m/s ² / 19.6m/s ²								
Speed/Torque Control Mode	Performance	Speed Control Range	1: 5000 (The lowest speed of the speed control range is the speed at which the servomotor will not stop with a rated torque load.)							
		Speed Regulation	Load Regulation	0% to 100% load: ±0.01% max. (at rated speed)						
			Voltage Regulation	Rated voltage ±10%: 0% (at rated speed)						
			Temperature Regulation	25±25°C: ±0.1% max. (at rated speed)						
		Frequency Characteristics	400 Hz (at $J_L = J_M$)							
	Torque Control Tolerance (Repeatability)	±2%								
	Soft Start Time Setting	0 to 10 s (Can be set individually for acceleration and deceleration.)								
	Input Signals	Speed Reference	Reference Voltage	±6 VDC (Variable setting range: ±2 to ±10 VDC) at rated speed (servomotor forward rotation with positive reference), input voltage: ±12 V max.						
			Input Impedance	Approx. 14kΩ						
			Circuit Time Constant	Approx. 47μs						
Torque Reference		Reference Voltage	±3 VDC (Variable setting range: ±1 to ±10 VDC) at rated speed (positive torque reference with positive reference), input voltage: ±12 V max.							
		Input Impedance	Approx. 14kΩ							
Circuit Time Constant	Approx. 47μs									
Position Control Mode	Performance	Bias Setting	0 to 450 min ⁻¹ (setting resolution: 1 min ⁻¹)							
		Feed-forward Compensation	0% to 100% (setting resolution: 1%)							
		Positioning Completion Width Setting	0 to 450 reference units (setting resolution: 1 reference unit)							
	Input Signals	Reference Pulse	Type	Select one signal from: Sign+pulse train, CCW+CW pulse train, and 90° phase difference 2-phase pulse (phase A + phase B).						
			Form	Line driver (+5 V level), open collector (+5 V or +12 V level)						
Frequency	0 to 250 kpps, 200 kpps max. when an open collector is used.									
Control Signal	CLEAR (Input pulse form is identical to reference pulse.)									
I/O Signals	Position Output	Phase A, phase B, phase C, or phase S (phase S used only with an absolute encoder): Line driver output								
	Sequence Input Signal	Servo ON, P control (or Control Mode switching, zero clamping, or reference pulse inhibit), forward/reverse run prohibited (P-OT/N-OT), alarm reset, forward/reverse current limit (or internal speed selection)								
	Sequence Output Signal	Servo alarm, alarm code (3-bit output): Output terminal for CN1 is fixed. Select three signals from: Servo ready, positioning completed (speed coincidence), rotation detection, current limit, speed limit, brake release, warning, or NEAR signal.								
Built-in Functions	Communications	Interface	Digital operator (hand-held type) RS-422A port such as for PCs (RS-232C port under certain conditions)							
		1: N Communications	Up to N=14 for RS-422A port							
		Axis Address Setting	Set with parameters.							
		Functions	Status display, parameter settings, monitor display, alarm traceback display, JOG and autotuning operations, speed, torque reference signal and other drawing functions							
	Autotuning	Position/speed loop gain and integral time constant can be automatically set.								
	Dynamic Brake (DB)	Operated at main power OFF, servo alarm, servo OFF, or overtravel.								
	Regenerative Processing	External regenerative resistor (option): 30 to 400 W; Built-in regenerative resistor: 750 W								
	Overtravel Prevention (OT)	DB stop, deceleration to a stop, or coasting to a stop at P-OT or N-OT								
	Encoder Divider	The number of pulses that can be set is limited.								
	Electronic Gear	0.01 < A/B < 100								
	Internal Speed Setting	Three speeds may be internally set.								
	Protective Functions	Overcurrent, overvoltage, undervoltage, overload, regeneration error, main circuit sensor error, heat sink overheat, power phase loss, overflow, overspeed, encoder error, overrun protection, CPU error, parameter error, etc.								
Analog Monitor	Analog monitor connector built-in for monitoring speed, torque, and other reference signals.									
Indicators (LED Display)	CHARGE, POWER, five 7-segment LEDs (built-in digital operator function)									
Others	Reverse rotation connection, origin search, DC reactor connection terminal for harmonic suppressions, automatic motor discrimination function									

● External Dimensions Units: mm

SGDS-02

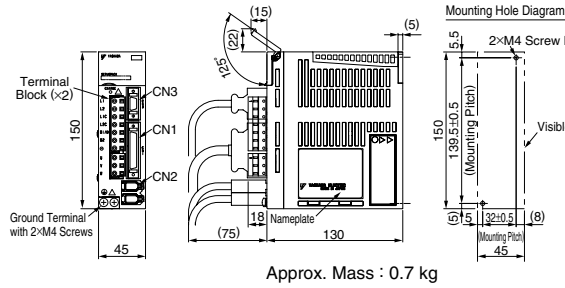

SGDS-08, 10

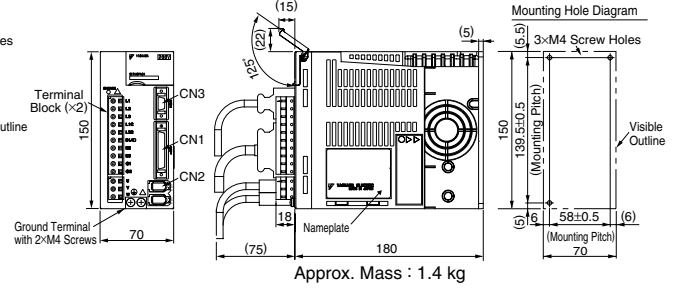

SGDS-04F

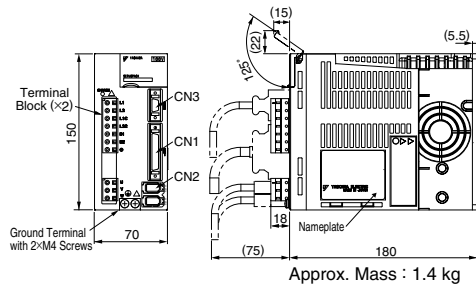

SGDS-15

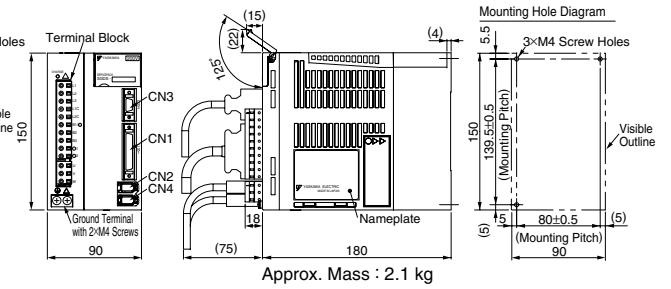

SGDS-04A

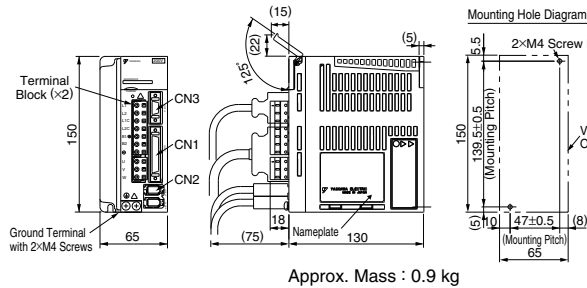

SGDS-20, 30

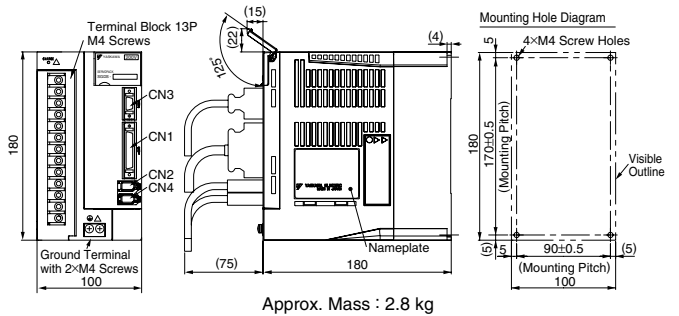

Connectors on SERVOPACK Side (Common for all models)

Connector Code	Model	Manufacturer
CN1	10250-52A2JL	SUMITOMO 3M Ltd.
CN2	53460-0611	Molex Japan Co., Ltd.
CN3	10214-52A2JL	SUMITOMO 3M Ltd.

Note: Use connectors above or equivalent.

SGDH-15

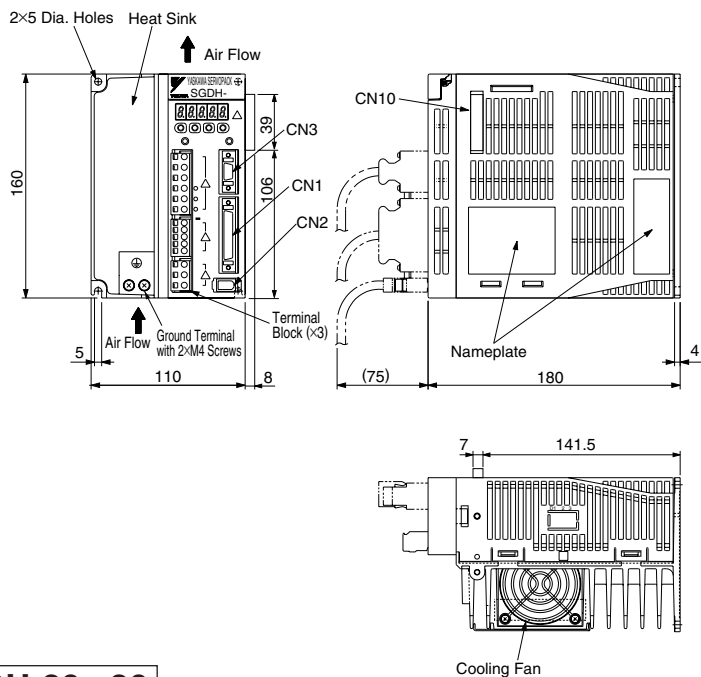

Mounting Hole Diagram

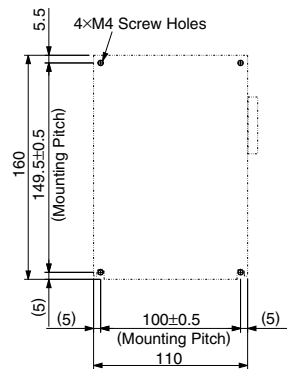

Approx. Mass: 2.8 kg

SGDH-20, -30

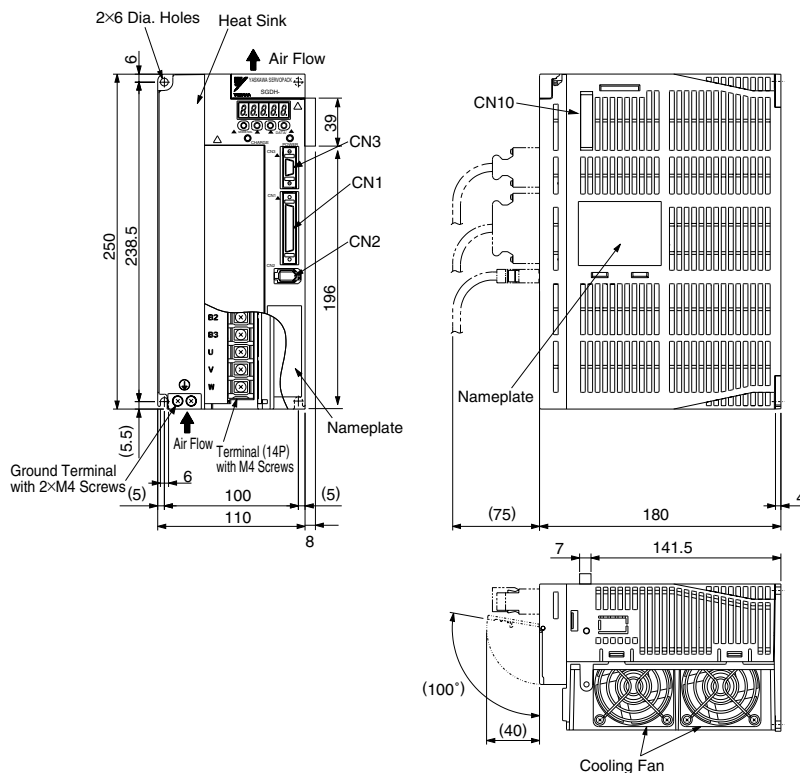

Mounting Hole Diagram

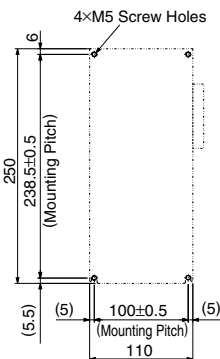

Approx. Mass: 3.8 kg

Connectors on SERVOPACK Side (Common for all models)

Connector Code	Model	Manufacturer
CN1	10250-52A2JL	SUMITOMO 3M Ltd.
CN2	53460-0611	Molex Japan Co., Ltd.
CN3	10214-52A2JL	SUMITOMO 3M Ltd.

Note: Use connectors above or equivalent.

Connection Diagrams

Single-phase 100/200 VAC (When using SGDS SERVOPACK)

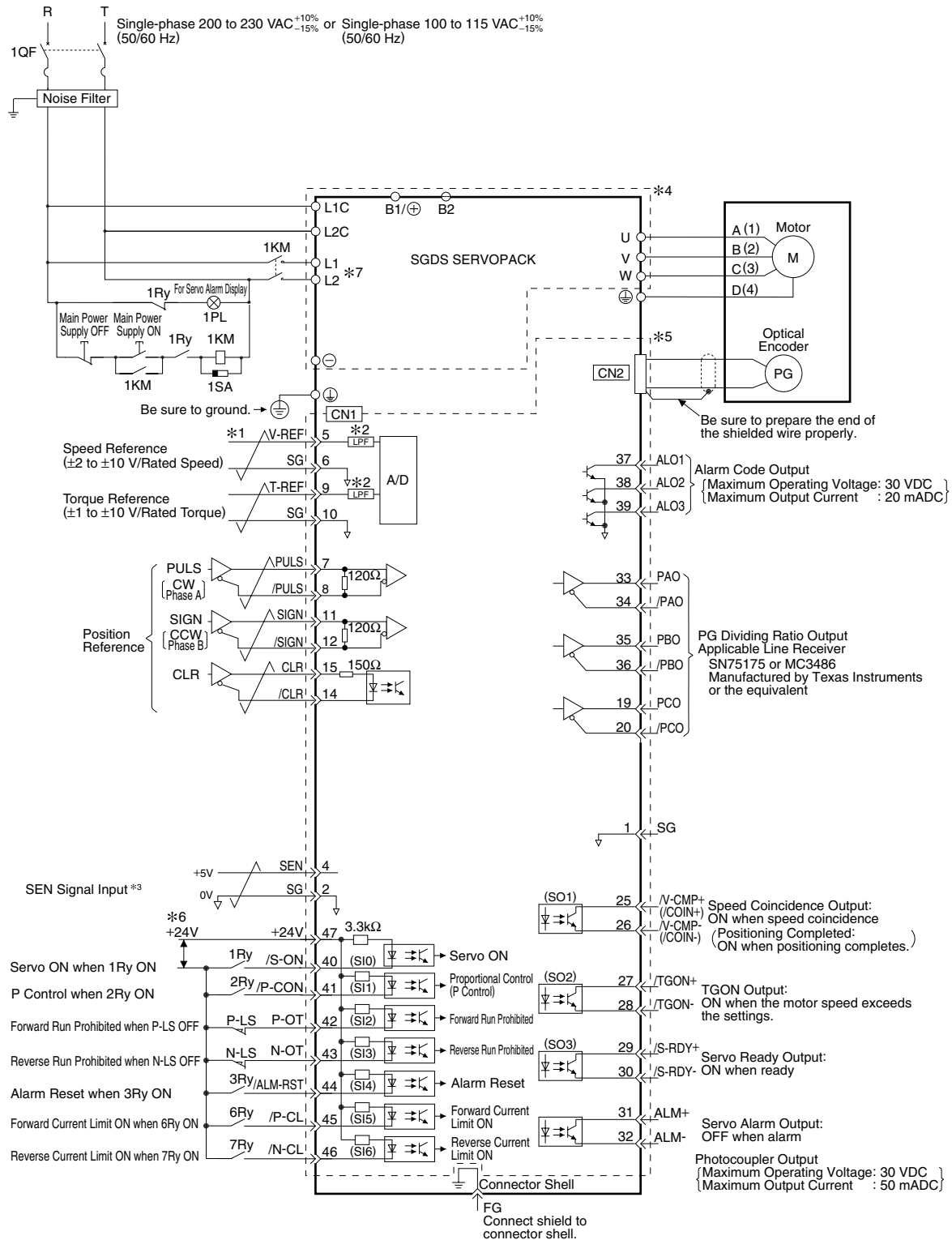

- *1 : represents twisted-pair wires.
- *2 : The time constant for the primary filter is 30 μ s.
- *3 : Connect when using an absolute encoder.
- *4 : This circuit is electrically separated from the outside to prevent electric shock.
- *5 : This is a SELV circuit separated from other circuits by double or reinforced insulation.
- *6 : Customers must purchase a 24-VDC power supply with double insulation.
- *7 : Add an L3 terminal for three-phase power supply.

● Single-phase 200 VAC (When using SGDH SERVOPACK)

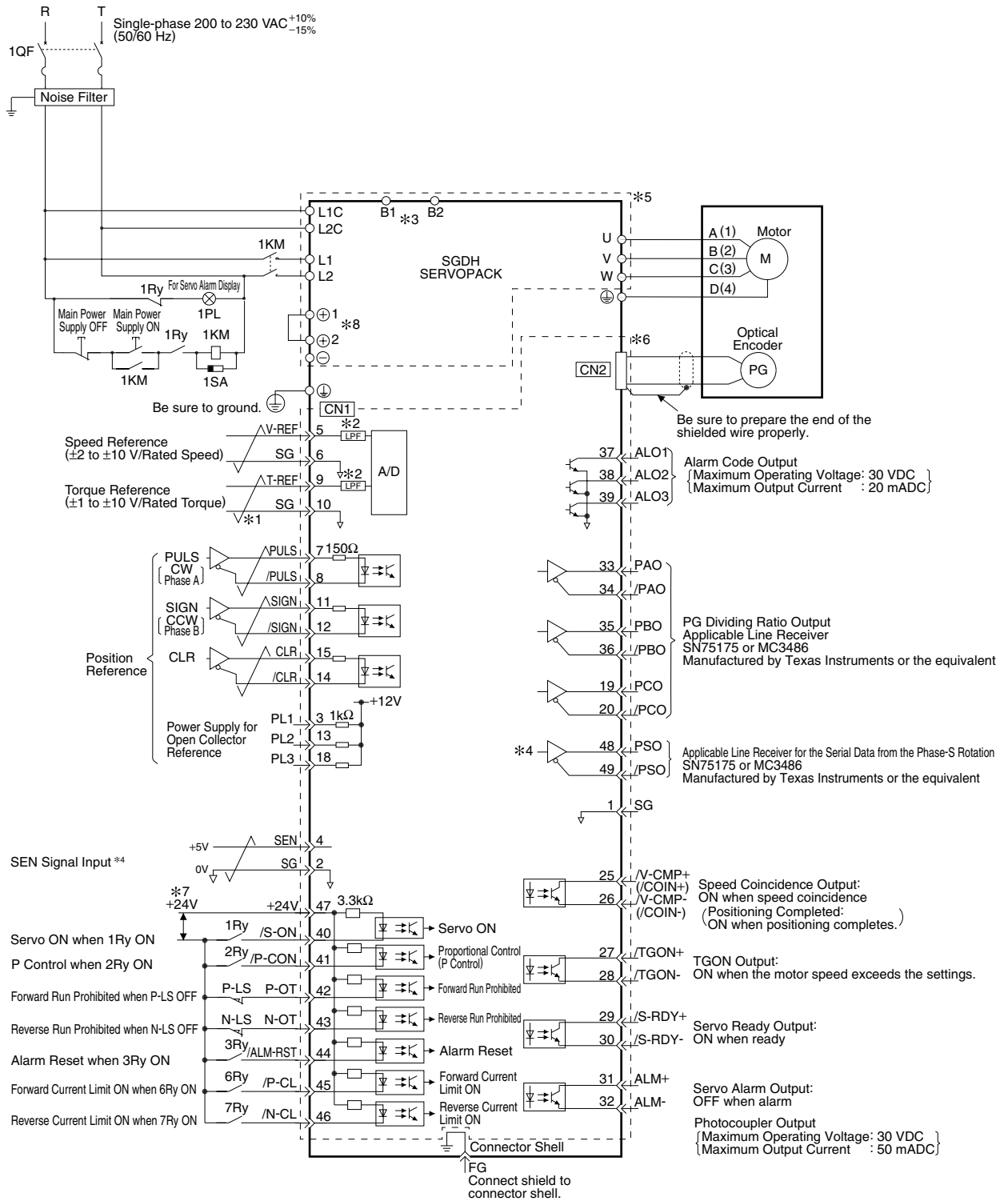

- *1 : represents twisted-pair wires.
- *2 : The time constant for the primary filter is 47 μ s.
- *3 : A regenerative resistor can be connected between terminals B1 and B2.
- *4 : Connect when using an absolute encoder.
- *5 : This circuit is electrically separated from the outside to prevent electric shock.
- *6 : This is a SELV circuit separated from other circuits by double or reinforced insulation.
- *7 : Customers must purchase a 24-VDC power supply with double insulation.
- *8 : Place a DC reactor between terminals $\oplus 1$ and $\oplus 2$ to suppress high harmonic waves.

Connection Diagrams

● Three-phase 200 VAC (When using SGDH SERVOPACK)

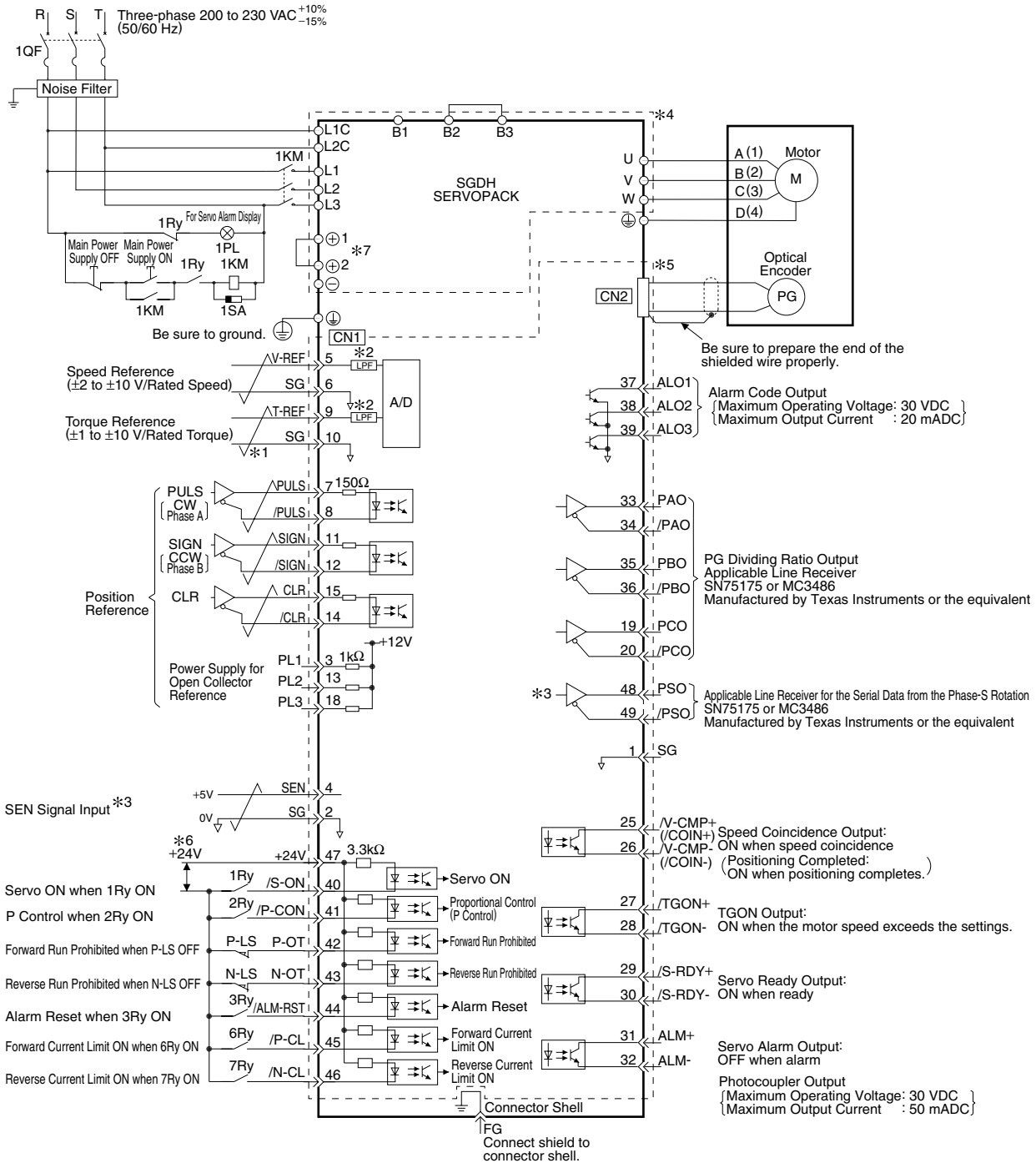

Ordering Reference

System Configuration

Refer to the following pages for ordering.

- Servo drives: p.29
- Peripheral Devices ① to ⑤: p.30
- Cables and Connectors: p.31

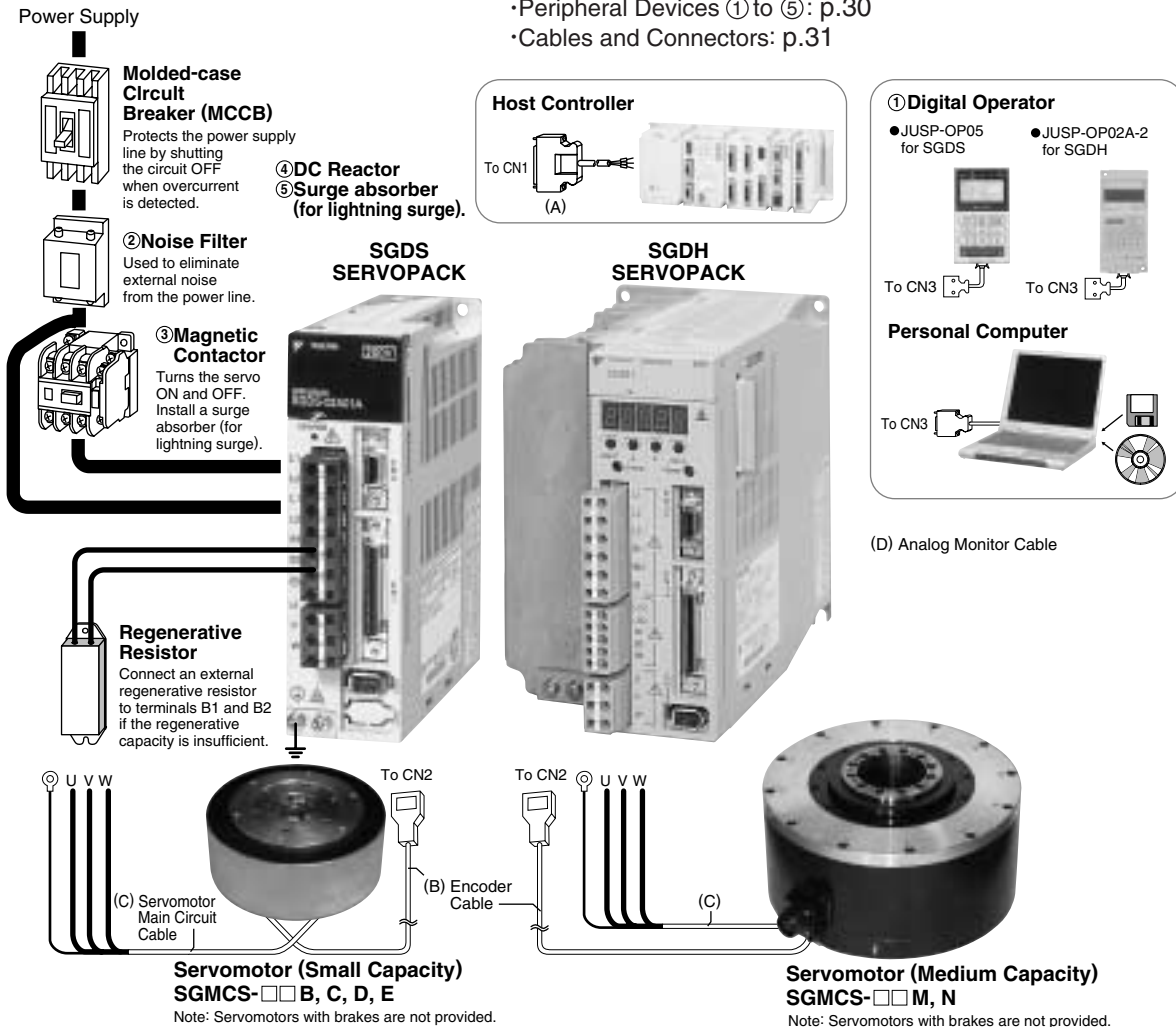

Order List

Servo Drives







Servomotors				SERVOPACK				
Series	Model SGMCS-	Rated Torque	Σ -III Series Model SGDS-			Σ -II Series Model SGDH-		
			Single-phase 100 V	Single-phase 200 V	Three-phase 200 V	Single-phase 200 V	Three-phase 200 V	
			Small Capacity	Outer diameter: 135 mm	02B	2	02F	02A
05B	5	02F			02A	—	02AE	—
07B	7	02F			02A	—	02AE	—
Outer diameter: 175 mm	04C	4		04F	04A	—	04AE	—
	10C	10		04F	04A	—	04AE	—
	14C	14		04F	04A	—	04AE	—
Outer diameter: 230 mm	08D	8		04F	04A	—	04AE	—
	17D	17		04F	04A	—	04AE	—
	25D	25		04F	04A	—	04AE	—
Outer diameter: 290 mm	16E	16		—	08A	—	—	08AE
	35E	35	—	08A	—	—	08AE	
Medium Capacity	Outer diameter: 280 mm	45M	45	—	—	10A	—	10AE
		80M	80	—	—	15A	—	15AE
		1AM	110	—	—	20A	—	20AE
	Outer diameter: 360 mm	80N	80	—	—	15A	—	15AE
		1EN	150	—	—	30A	—	30AE
		2ZN	200	—	—	30A	—	30AE

Ordering Reference

Peripheral Devices

Name	Model	Specifications	Dimensions (P.32)	
① Digital Operator	JUSP-OP05A	SGDS	A cable (1m) is provided.	
	JUSP-OP02A-2	SGDH		
	Cable	(JZSP-CMS00-1)		1 m
		(JZSP-CMS00-2)		1.5 m
	(JZSP-CMS00-3)	2 m		
		Required when a JUSP-OP02A-1 digital operator for the Σ series is used (only when using SGDH SERVOPACK).		
② Noise Filter (Made by Schaffner EMC Inc.)	FN2070-6/07	Power supply voltages and capacities for applicable SERVOPACKs	Single-phase 200 V 200 W	
	FN2070-10/07		Single-phase 100 V 200 W	
			Single-phase 200 V 400 W	
	FN2070-16/07		Single-phase 100 V 400 W	
			Single-phase 200 V 750 W	
	FN258L-16/07		Three-phase 200 V 0.75 to 2 kW	
	FN258L-30/07		Three-phase 200 V 3 kW	
③ Magnetic Contactor (Made by YASKAWA Siemens Automation & Drives Corp.)	HI-11J (20A)	Power supply voltages and capacities for applicable SERVOPACKs	Single-phase 100 V 200 W	
			Single-phase 200 V 200 W	
	HI-15J (35A)		Single-phase 200 V 400 W	
			Single-phase 100 V 400 W	
			Single-phase 200 V 750 W	
④ DC reactor for power supply harmonic suppression	X5054	Power supply voltages and capacities for applicable SERVOPACKs (SGDS)	Single-phase 100 V 200 W	
			Single-phase 200 V 400 W	
	X5056		Single-phase 100 V 400 W	
			Single-phase 200 V 750 W	
	X5053		Single-phase 200 V 200 W	
	X5061	Three-phase 200 V 1 kW		
	X5060	Three-phase 200 V 1.5 kW		
		Three-phase 200 V 2.0 kW		
	X5059	Three-phase 200 V 3.0 kW		
	X5070	Power supply voltages and capacities for applicable SERVOPACKs (SGDH)	Single-phase 200 V 200 W	
	X5069		Single-phase 200 V 400 W	
X5061	Three-phase 200 V 750 W			
X5060	Three-phase 200 V 1.5 kW, 2 kW			
X5059	Three-phase 200 V 3 kW			
⑤ Surge Absorber (Made by Okaya Electric Industries Co., Ltd) Brand Name: Surge Protector	R·C·M-601BQZ	–	–	

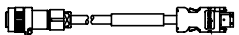
Cables and Connectors [Made by Yaskawa Control Co., Ltd.]

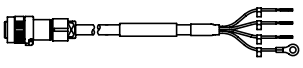
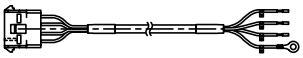
Name		Model	Specifications	Dimensions (p.32, 33)	
(A) CN 1 For I/O Signals	Connector Terminal Block Converter Unit	JUSP-TA50P	Terminal block and 0.5-m connection cable 	Ⓓ	
	Cable with Loose Wires at One End (SGDH)	JZSP-CKI01-1	1 m (Loose wires at customer end)		Ⓔ
		JZSP-CKI01-2	2 m		
		JZSP-CKI01-3	3 m		
	Cable with Loose Wires at One End (SGDS)	JZSP-CSI01-1	1 m (Loose wires at customer end)		-
		JZSP-CSI01-2	2 m		
		JZSP-CSI01-3	3 m		
	Connector Kit for CN1	JZSP-CSI9-1	SGDS	Connector and case 	Ⓕ
		JZSP-CKI9	SGDH		
	(B) CN 2 Encoder	Cable with Connectors at Both Ends SGMCS-□□B -□□C -□□D -□□E -□□M -□□N	JZSP-CMP60-03	3 m	Applicable flange specifications*: 1, 3
JZSP-CMP60-05			5 m		
JZSP-CMP60-10			10 m		
JZSP-CMP60-15			15 m		
JZSP-CMP60-20			20 m		
JZSP-CMP00-03			3 m		Applicable flange specifications*: 4
JZSP-CMP00-05			5 m		
JZSP-CMP00-10			10 m		
JZSP-CMP00-15			15 m		
JZSP-CMP00-20			20 m		
JZSP-CMM60-03			3 m		Applicable flange specifications*: 1
JZSP-CMM60-05			5 m		
JZSP-CMM60-10			10 m		
JZSP-CMM60-15	15 m				
JZSP-CMM60-20	20 m				
JZSP-CMM00-03	3 m	Applicable flange specifications*: 4			
JZSP-CMM00-05	5 m				
JZSP-CMM00-10	10 m				
JZSP-CMM00-15	15 m				
JZSP-CMM00-20	20 m				
(C) SERVOPACK Motor	Servomotor Main Circuit Cable SGMCS-□□B -□□C -□□D -□□E	JZSP-CMM60-03	3 m	Applicable flange specifications*: 1, 3	Ⓕ
		JZSP-CMM60-05	5 m		
		JZSP-CMM60-10	10 m		
		JZSP-CMM60-15	15 m		
JZSP-CMM60-20	20 m				
Connector for Servomotor Main Circuit Cable at Servomotor Side SGMCS-□□M -□□N	Customers must prepare or assemble the cable. Applicable flange specifications*: 1, 3		-		
	L-Shaped plug: MS3108B18-10S				
	Straight plug: MS3106B18-10S				
	Cable clamp: MS3057-10A				
(D) CN 5	Analog Monitor Cable	DE9404559	1 m	Ⓖ	

*: Refer to Model Designations on p.5 for flange specifications.

Ordering Reference

● Dimensions for Peripheral Devices and Cables Units: mm

(A) Cable for Digital Operator

JUSP-OP05A + Cable

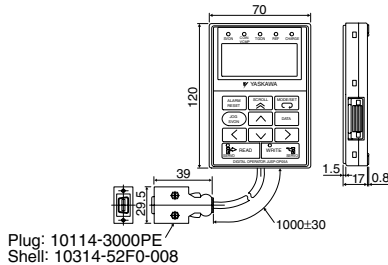

Cable for JUSP-OP02A

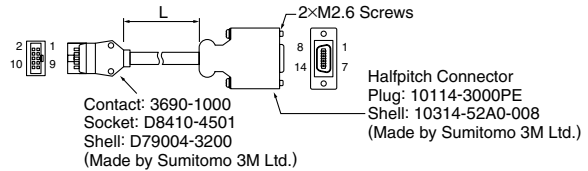

(B) Noise Filter (Screw-terminal type)

Made by Schaffner EMC Inc.

Drawing 1

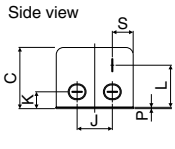

Drawing 2

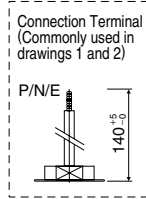
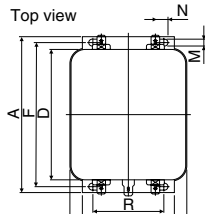
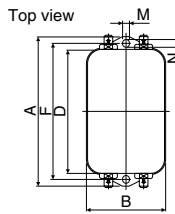
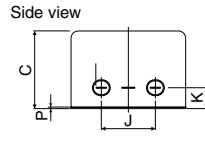

Drawing 3

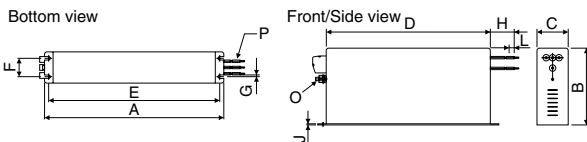

Code	Tolerances	Model			Code	Tolerances	Model	
		FN2070-6/07	FN2070-10/07	FN2070-16/07			FN258L-16/07	FN258L-30/07
		Drawing 1	Drawing 2			Drawing 3		
A	±1	113.5	156	119±0.5	A	±1	305	335
B	±1	57.5		85.5	B	-	142±0.8	150±1
C	-	45.4±1.2		57.6	C	±0.6	55	60
D	±1	94	130.5	98.5	D	±1	275±0.8	305
F	±0.3	103	143	109	E	±0.5	290	320
J	±0.2	25		40	F	±0.3	30	35
K	±0.5	8.4		8.6	G	±0.2	6.5	6.5
L	±0.5	32.4		-	H	±10	300	400
M	±0.1	4.4	5.3	4.4	J	±0.2	1±0.1	1.5
N	±0.1	6		7.4	L	±1	9	12
P	±0.1	0.9		1.2	O	-	M5	M6
Q	±0.3	-		66	P	-	AWG14	AWG10
R	±0.2	-		51	Spec.*2 480 VAC, 16 A 480 VAC, 30 A			
S	±0.5	38		-	*1: The rated current is the value at +40°C. *2: The rated current is the value at +50°C.			
Spec.*1		250 VAC, 6 A	250 VAC, 10 A	250 VAC, 16 A				

(C) DC Reactor for Power Supply Harmonic Suppression

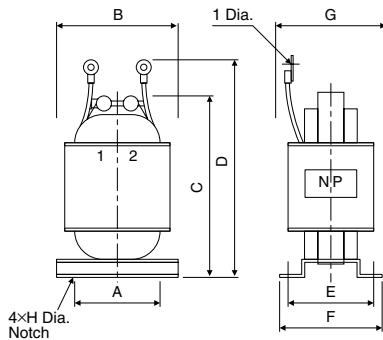

Model*	Inductance mH	Rated Current A	Dimensions mm									Approx. Mass kg
			A	B	C	D	E	F	G	H	I	
X5070	20.0	1.65	40	59	100	120	35	45	50	4	4.3	0.8
X5069	10.0	3.3	40	59	105	125	45	60	65	4	4.3	1.0
X5061	2.0	4.8	35	52	80	95	35	45	50	4	4.3	0.5
X5060	1.5	8.0	40	59	105	125	45	60	65	4	4.3	1.0
X5059	1.0	14.0	50	74	125	140	35	45	60	5	5.3	1.1
X5056	2.0	5.0	35	52	80	95	30	40	45	4	4.3	0.4
X5054	5.0	5.0	35	52	80	95	30	40	45	4	4.3	0.4
X5053	20.0	2.0	35	52	90	105	35	45	50	4	4.3	0.6

*: Model used for orders from the Yaskawa Electric Corporation.

(D) Connector Terminal Block Converter Unit (for CN1)

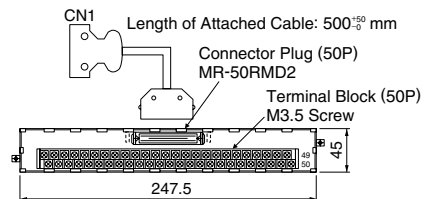

(E) Cable with Loose Wires at One End (for CN1)

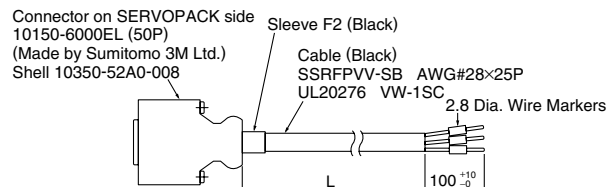

F Connector Kit for I/O Signals (for CN1)

Made by SUMITOMO 3M Ltd.

Case: 10350-52Z0-008 (SGDS)
10350-52A0-008 (SGDH)

Connector: 10114-3000PE

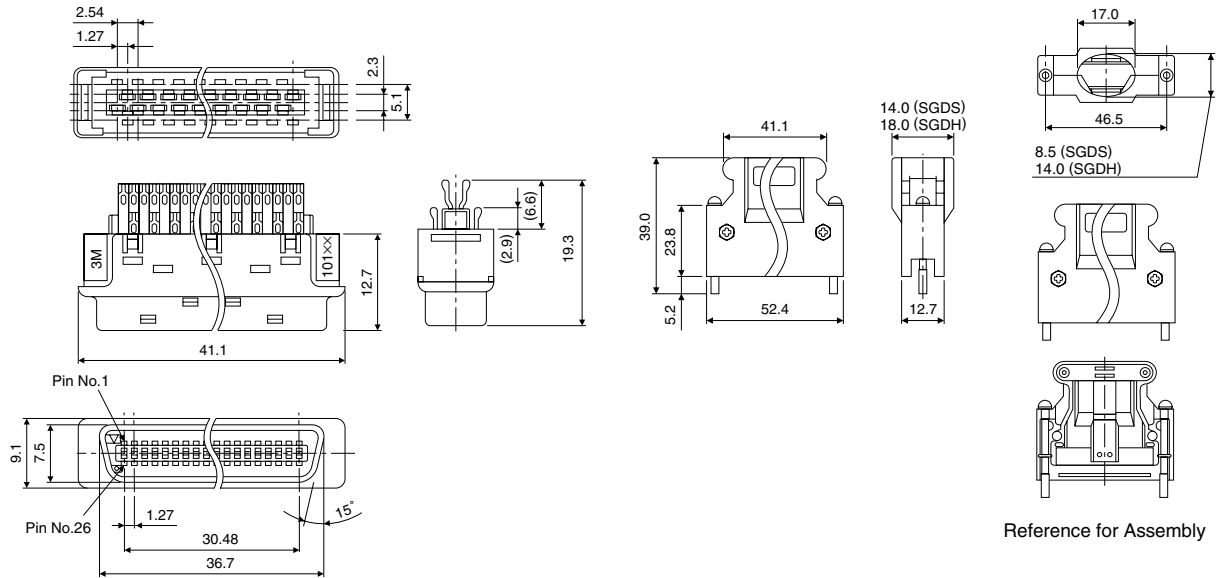

G Cable with Both End Connectors (for CN2)

Note: Refer to Model Designations on p.5 for flange specifications.

Applicable Flange Specifications: 1, 3

Applicable Flange Specifications: 4

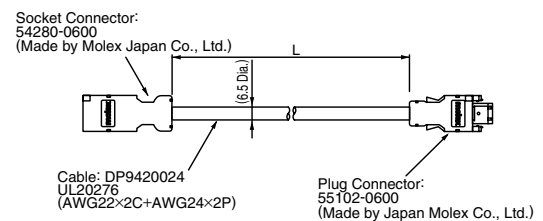
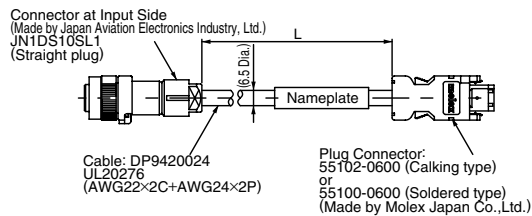

H Servomotor Main Circuit Cable

Note: Refer to Model Designations on p.5 for flange specifications.

Applicable Flange Specifications: 1

Applicable Flange Specifications: 4

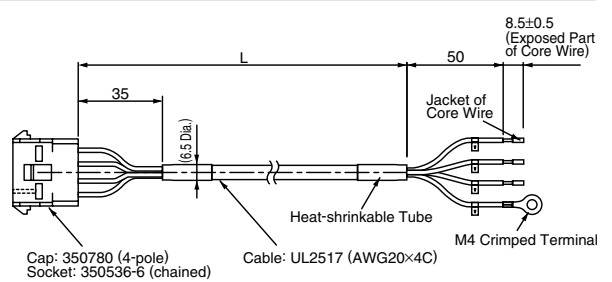
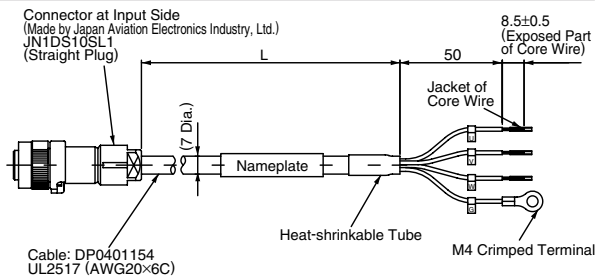

I Analog Monitor Cable

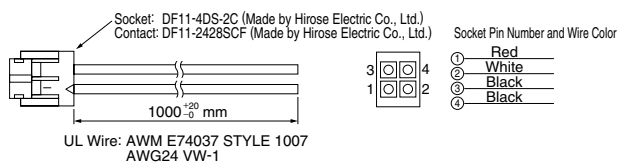

DIRECT DRIVE Σ SERIES

IRUMA BUSINESS CENTER (SOLUTION CENTER)

480, Kamifujisawa, Iruma, Saitama 358-8555, Japan
Phone 81-4-2962-5696 Fax 81-4-2962-6138

YASKAWA ELECTRIC AMERICA, INC.

2121 Norman Drive South, Waukegan, IL 60085, U.S.A.
Phone 1-847-887-7000 Fax 1-847-887-7370

YASKAWA ELÉTRICO DO BRASIL LTDA.

Avenida Fagundes Filho, 620 São Paulo-SP CEP 04304-000, Brazil
Phone 55-11-3585-1100 Fax 55-11-5581-8795

YASKAWA ELECTRIC EUROPE GmbH

Am Kronberger Hang 2, 65824 Schwalbach, Germany
Phone 49-6196-569-300 Fax 49-6196-569-312

YASKAWA ELECTRIC UK LTD.

1 Hunt Hill Orchardton Woods Cumbernauld, G68 9LF, United Kingdom
Phone 44-1236-735000 Fax 44-1236-458182

YASKAWA ELECTRIC KOREA CORPORATION

9F, Kyobo Securities Bldg., 26-4, Yeouido-dong, Yeongdeungpo-gu, Seoul 150-737, Korea
Phone 82-2-784-7844 Fax 82-2-784-8495

YASKAWA ELECTRIC (SINGAPORE) PTE. LTD.

151 Lorong Chuan, #04-01, New Tech Park 556741, Singapore
Phone 65-6282-3003 Fax 65-6289-3003

YASKAWA ELECTRIC (SHANGHAI) CO., LTD.

No.18 Xizang Zhong Road, Room 1702-1707, Harbour Ring Plaza Shanghai 200001, China
Phone 86-21-5385-2200 Fax 86-21-5385-3299

YASKAWA ELECTRIC (SHANGHAI) CO., LTD. BEIJING OFFICE

Room 1011A, Tower W3 Oriental Plaza, No.1 East Chang An Ave.,
Dong Cheng District, Beijing 100738, China
Phone 86-10-8518-4086 Fax 86-10-8518-4082

YASKAWA ELECTRIC TAIWAN CORPORATION

9F, 16, Nanking E. Rd., Sec. 3, Taipei, Taiwan
Phone 886-2-2502-5003 Fax 886-2-2505-1280



YASKAWA ELECTRIC CORPORATION

In the event that the end user of this product is to be the military and said product is to be employed in any weapons systems or the manufacture thereof, the export will fall under the relevant regulations as stipulated in the Foreign Exchange and Foreign Trade Regulations. Therefore, be sure to follow all procedures and submit all relevant documentation according to any and all rules, regulations and laws that may apply.

Specifications are subject to change without notice for ongoing product modifications and improvements.

© 2002-2011 YASKAWA ELECTRIC CORPORATION. All rights reserved.

LITERATURE NO. KAEP S800000 06D

Published in Japan June 2011 02-10 \diamond -1

Printed on 100% recycled paper with soybean oil ink.